



Vincotech

<i>flow NPC 0</i>	650 V / 50 A
<div style="border: 1px solid black; padding: 5px; margin-bottom: 10px;"> <p style="text-align: center; margin: 0;">Features</p> <ul style="list-style-type: none"> Neutral point clamped inverter Reactive power capability Low inductance layout Improved LVRT capability </div> <div style="border: 1px solid black; padding: 5px; margin-bottom: 10px;"> <p style="text-align: center; margin: 0;">Target Applications</p> <ul style="list-style-type: none"> Solar inverter UPS </div> <div style="border: 1px solid black; padding: 5px;"> <p style="text-align: center; margin: 0;">Types</p> <ul style="list-style-type: none"> 10-F007NRA050SG-P966F09 </div>	<div style="border: 1px solid black; padding: 5px; margin-bottom: 10px;"> <p style="text-align: center; margin: 0;"><i>flow 0 17mm housing</i></p> </div> <div style="border: 1px solid black; padding: 5px;"> <p style="text-align: center; margin: 0;">Schematic</p> </div>

Maximum Ratings

$T_j = 25\text{ °C}$, unless otherwise specified

Parameter	Symbol	Condition	Value	Unit
Buck Sw. Protection Diode				
Repetitive peak reverse voltage	V_{RRM}		650	V
Forward current	I_{FAV}	DC current	18	A
Power dissipation	P_{tot}	$T_j = T_{jmax}$	33	W
Maximum Junction Temperature	T_{jmax}		175	°C
Buck Switch				
Collector-emitter break down voltage	V_{CES}		650	V
DC collector current	I_C	$T_j = T_{jmax}$	51	A
Repetitive peak collector current	I_{CRM}	t_p limited by T_{jmax}	150	A
Turn off safe operating area		$T_j \leq 150\text{ °C}$ $V_{CE} \leq V_{CES}$	100	A
Power dissipation	P_{tot}	$T_j = T_{jmax}$	119	W
Gate-emitter peak voltage	V_{GE}		±20	V
Short circuit ratings	t_{SC} V_{CC}	$T_j \leq 150\text{ °C}$ $V_{GE} = 15\text{ V}$	5 400	µs V
Maximum Junction Temperature	T_{jmax}		175	°C



Vincotech

Maximum Ratings $T_j = 25\text{ }^\circ\text{C}$, unless otherwise specified

Parameter	Symbol	Condition	Value	Unit
-----------	--------	-----------	-------	------

Buck Diode

Peak Repetitive Reverse Voltage	V_{RRM}		600	V
DC forward current	I_F	$T_j = T_{jmax}$ $T_s = 80\text{ }^\circ\text{C}$	27	A
Repetitive peak forward current	I_{FRM}	t_p limited by T_{jmax}	70	A
Power dissipation	P_{tot}	$T_j = T_{jmax}$ $T_s = 80\text{ }^\circ\text{C}$	57	W
Maximum Junction Temperature	T_{jmax}		175	$^\circ\text{C}$

Boost Switch

Collector-emitter break down voltage	V_{CES}		1200	V
DC collector current	I_C	$T_j = T_{jmax}$ $T_s = 80\text{ }^\circ\text{C}$	41	A
Repetitive peak collector current	I_{CRM}	t_p limited by T_{jmax}	105	A
Turn off safe operating area		$T_j \leq 150\text{ }^\circ\text{C}$ $V_{CE} \leq V_{CES}$	70	A
Power dissipation	P_{tot}	$T_j = T_{jmax}$ $T_s = 80\text{ }^\circ\text{C}$	101	W
Gate-emitter peak voltage	V_{GE}		± 20	V
Short circuit ratings	t_{SC} V_{CC}	$T_j \leq 150\text{ }^\circ\text{C}$ $V_{GE} = 15\text{ V}$	10 800	μs V
Maximum Junction Temperature	T_{jmax}		175	$^\circ\text{C}$

Boost Sw. Protection Diode

Peak Repetitive Reverse Voltage	V_{RRM}	$T_c = 25\text{ }^\circ\text{C}$	1200	V
DC forward current	I_F	$T_j = T_{jmax}$ $T_s = 80\text{ }^\circ\text{C}$	16	A
Power dissipation	P_{tot}	$T_j = T_{jmax}$ $T_s = 80\text{ }^\circ\text{C}$	36	W
Maximum Junction Temperature	T_{jmax}		150	$^\circ\text{C}$

Boost Diode

Peak Repetitive Reverse Voltage	V_{RRM}		1200	V
DC forward current	I_F	$T_j = T_{jmax}$ $T_s = 80\text{ }^\circ\text{C}$	24	A
Surge forward current	I_{FSM}	10ms sin 180° $T_j = 150\text{ }^\circ\text{C}$	100	A
Power dissipation	P_{tot}	$T_j = T_{jmax}$ $T_s = 80\text{ }^\circ\text{C}$	61	W
Maximum Junction Temperature	T_{jmax}		175	$^\circ\text{C}$

Thermal Properties

Storage temperature	T_{stg}		-40...+125	$^\circ\text{C}$
Operation temperature under switching condition	T_{op}		-40...+($T_{jmax} - 25$)	$^\circ\text{C}$

Insulation Properties

Insulation voltage	V_{is}	$t = 2\text{ s}$ DC Test Voltage	4000	V
Creepage distance			min 12,7	mm
Clearance			min 12,7	mm
Comparative Tracking Index	CTI			



Characteristic Values

Parameter	Symbol	Conditions					Value			Unit				
		V_{GE} [V]	V_{GS} [V]	V_r [V]	V_{CE} [V]	V_{DS} [V]	I_C [A]	I_F [A]	I_D [A]		T_j [°C]	Min	Typ	Max
Buck Sw. Protection Diode														
Forward voltage	V_F					10				25 125	1,3	1,67 1,54	2	V
Reverse current	I_r				650					25			0,14	µA
Thermal resistance junction to sink	$R_{th(j-s)}$	phase-change material										2,87		K/W
Thermal resistance junction to case	$R_{th(j-c)}$	$\lambda = 3,4$ W/mK										1,89		
Buck Switch														
Gate emitter threshold voltage	$V_{GE(th)}$	$V_{CE} = V_{GE}$				0,0008				25	4,2	5,1	5,6	V
Collector-emitter saturation voltage	V_{CESat}		15			50				25 125	1,4	1,90 2,17	2,5	V
Collector-emitter cut-off current incl. Diode	I_{CES}		0	650						25			5	µA
Gate-emitter leakage current	I_{GES}		20	0						25			150	nA
Integrated Gate resistor	R_{gint}											none		Ω
Turn-on delay time	$t_{d(on)}$									25 125		67 67		ns
Rise time	t_r									25 125		7 9		
Turn-off delay time	$t_{d(off)}$	$R_{goff} = 4 \Omega$ $R_{gon} = 4 \Omega$	±15	350	35					25 125		106 129		
Fall time	t_f									25 125		7 16		
Turn-on energy loss	E_{on}									25 125		0,15 0,18		
Turn-off energy loss	E_{off}									25 125		0,24 0,46		
Input capacitance	C_{ies}											3100		pF
Output capacitance	C_{oss}	$f = 1$ MHz	0	25						25		tb.d.		
Reverse transfer capacitance	C_{rss}											90		
Gate charge	Q_G		±15	480	50					25		315		nC
Thermal resistance junction to sink	$R_{th(j-s)}$	phase-change material										0,80		K/W
Thermal resistance junction to case	$R_{th(j-c)}$	$\lambda = 3,4$ W/mK										0,53		
Buck Diode														
Diode forward voltage	V_F					16				25 125	1	1,38 1,49	1,7	V
Reverse leakage current	I_r				600					25			320	µA
Peak reverse recovery current	I_{RRM}									25 125		22 20		A
Reverse recovery time	t_{rr}									25 125		9 9		ns
Reverse recovered charge	Q_{rr}	$R_{gon} = 4 \Omega$	±15	350	35					25 125		0,08 0,17		µC
Peak rate of fall of recovery current	$(di_{rr}/dt)_{max}$									25 125		8029 7036		A/µs
Reverse recovered energy	E_{rec}									25 125		0,01 0,03		mWs
Thermal resistance junction to sink	$R_{th(j-s)}$	phase-change material										1,68		K/W
Thermal resistance junction to case	$R_{th(j-c)}$	$\lambda = 3,4$ W/mK										1,10		



Characteristic Values

Parameter	Symbol	Conditions					Value			Unit			
		V_{GE} [V]	V_{GS} [V]	V_r [V]	V_{CE} [V]	V_{DS} [V]	I_C [A]	I_F [A]	I_D [A]		T_j [°C]	Min	Typ
Boost Switch													
Gate emitter threshold voltage	$V_{GE(th)}$	$V_{CE} = V_{GE}$				0,0012	25			5	5,8	6,5	V
Collector-emitter saturation voltage	V_{CESat}		15			35	25 125			1,6	2,06 2,14	2,3	V
Collector-emitter cut-off incl diode	I_{CES}		0	1200			25					0,005	mA
Gate-emitter leakage current	I_{GES}		20	0			25					120	nA
Integrated Gate resistor	R_{gint}										none		Ω
Turn-on delay time	$t_{d(on)}$	$R_{goff} = 4 \Omega$ $R_{gon} = 4 \Omega$	± 15	350	35		25				44		ns
Rise time	t_r						125				45		
Turn-off delay time	$t_{d(off)}$						25				5		
Fall time	t_f						125				8		
Turn-on energy loss	E_{on}						25				148		
Turn-off energy loss	E_{off}						125				192		
Input capacitance	C_{ies}	$f = 1 \text{ MHz}$	0	25		25					1950		pF
Output capacitance	C_{oss}										155		
Reverse transfer capacitance	C_{rss}										115		
Gate charge	Q_G		15	480	35	25				tbd.			nC
Thermal resistance junction to sink	$R_{th(j-s)}$	phase-change material									0,94		K/W
Thermal resistance junction to case	$R_{th(j-c)}$	$\lambda = 3,4 \text{ W/mK}$									0,62		
Boost Sw. Protection Diode													
Diode forward voltage	V_F					7	25 125			1,60	2,01 1,66	2,60	V
Reverse current	I_r			1200			25					250	μA
Thermal resistance junction to sink	$R_{th(j-s)}$	Thermal grease thickness $\leq 50 \mu\text{m}$									1,92		K/W
Thermal resistance junction to case	$R_{th(j-c)}$	$\lambda = 1 \text{ W/mK}$									1,27		
Boost Diode													
Diode forward voltage	V_F					25	25 125			2	2,30 2,40	2,9	V
Reverse leakage current	I_r			1200			25					60	μA
Peak reverse recovery current	I_{RRM}	$R_{gon} = 4 \Omega$	± 15	350	35		25				65		A
Reverse recovery time	t_{rr}						125				67		
Reverse recovered charge	Q_{rr}						25				43		
Peak rate of fall of recovery current	$(di_{rr}/dt)_{max}$						125				122		
Reverse recovery energy	E_{rec}						25				2,24		
							125				4,25		
Thermal resistance junction to sink	$R_{th(j-s)}$	phase-change material									1,56		K/W
Thermal resistance junction to case	$R_{th(j-c)}$	$\lambda = 3,4 \text{ W/mK}$									1,03		
Thermistor													
Rated resistance	R						25				21511		Ω
Deviation of R_{100}	$\Delta_{R/R}$	$R_{100} = 1486 \Omega$					100			-4,5		+4,5	%
Power dissipation	P						25				210		mW
Power dissipation constant							25				3,5		mW/K
B-value	$B_{(25/50)}$						25				3884		K
B-value	$B_{(25/100)}$	Tol. $\pm 1\%$					25				3964		K
Vincotech NTC Reference												E	



Buck

figure 1. IGBT

Typical output characteristics

$I_C = f(V_{CE})$

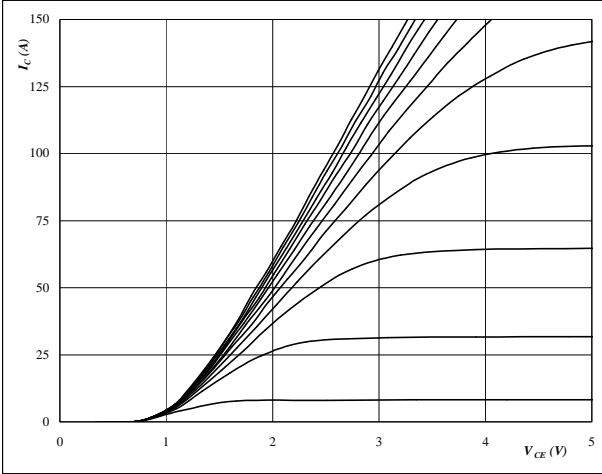

At
 $t_p = 250 \mu s$
 $T_j = 25 \text{ }^\circ C$
 V_{GE} from 7 V to 17 V in steps of 1 V

figure 2. IGBT

Typical output characteristics

$I_C = f(V_{CE})$

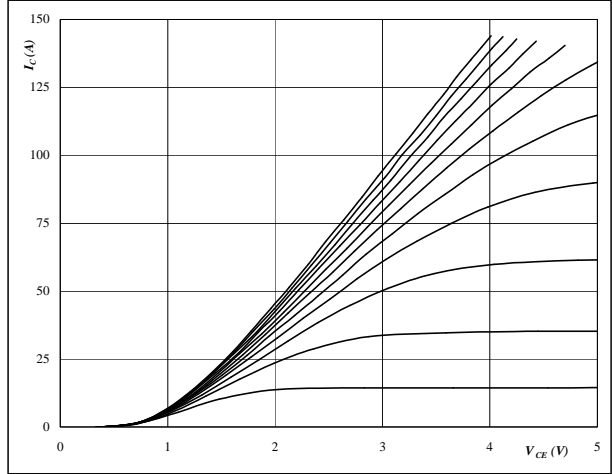

At
 $t_p = 250 \mu s$
 $T_j = 125 \text{ }^\circ C$
 V_{GE} from 7 V to 17 V in steps of 1 V

figure 3. IGBT

Typical transfer characteristics

$I_C = f(V_{GE})$

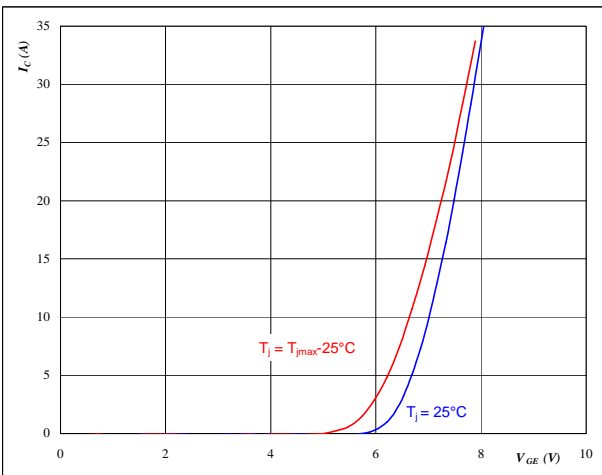

At
 $t_p = 250 \mu s$
 $V_{CE} = 10 V$

figure 4. FWD

Typical diode forward current as a function of forward voltage

$I_F = f(V_F)$

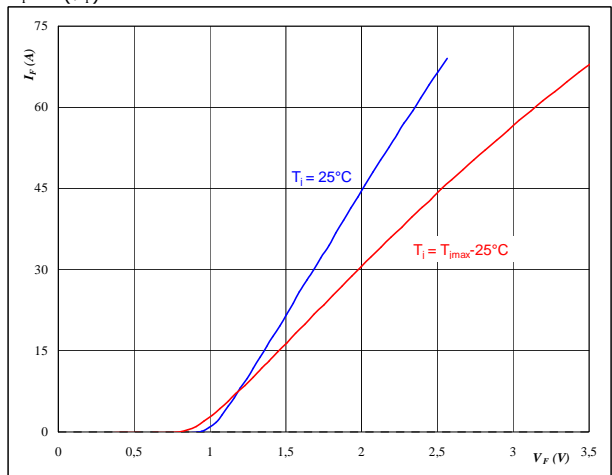

At
 $t_p = 250 \mu s$



Buck

figure 5. IGBT

Typical switching energy losses as a function of collector current

$$E = f(I_C)$$

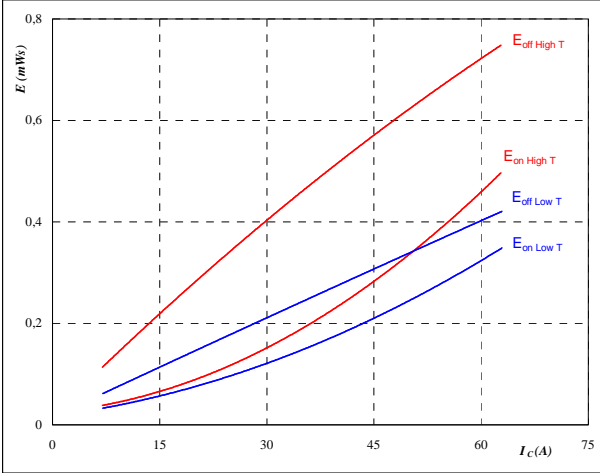

With an inductive load at

$T_j =$	25/125	°C
$V_{CE} =$	350	V
$V_{GE} =$	±15	V
$R_{gon} =$	4	Ω
$R_{goff} =$	4	Ω

figure 6. IGBT

Typical switching energy losses as a function of gate resistor

$$E = f(R_G)$$

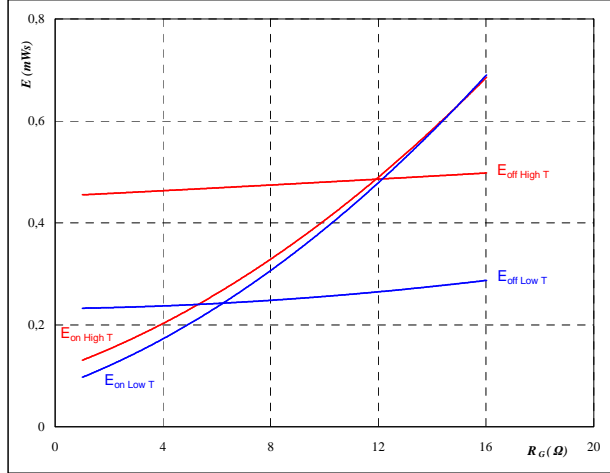

With an inductive load at

$T_j =$	25/125	°C
$V_{CE} =$	350	V
$V_{GE} =$	±15	V
$I_C =$	35	A

figure 7. FWD

Typical reverse recovery energy loss as a function of collector current

$$E_{rec} = f(I_C)$$

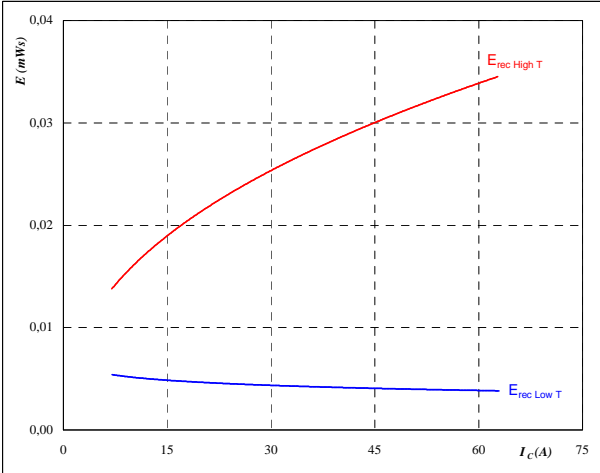

With an inductive load at

$T_j =$	25/125	°C
$V_{CE} =$	350	V
$V_{GE} =$	±15	V
$R_{gon} =$	4	Ω

figure 8. FWD

Typical reverse recovery energy loss as a function of gate resistor

$$E_{rec} = f(R_G)$$

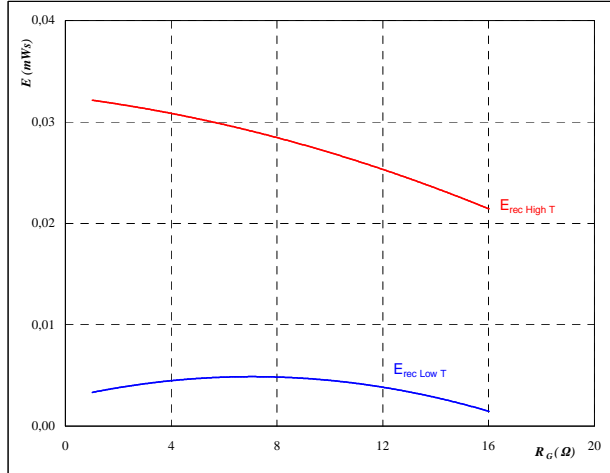

With an inductive load at

$T_j =$	25/125	°C
$V_{CE} =$	350	V
$V_{GE} =$	±15	V
$I_C =$	35	A



Buck

figure 9. IGBT

Typical switching times as a function of collector current

$$t = f(I_C)$$

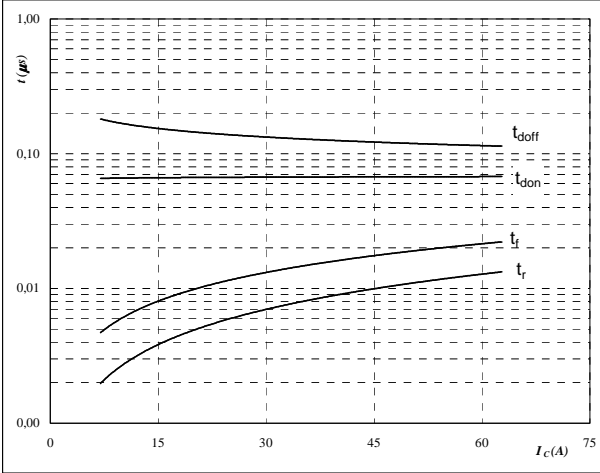

With an inductive load at

$T_j =$	125	°C
$V_{CE} =$	350	V
$V_{GE} =$	±15	V
$R_{gon} =$	4	Ω
$R_{goff} =$	4	Ω

figure 10. IGBT

Typical switching times as a function of gate resistor

$$t = f(R_G)$$

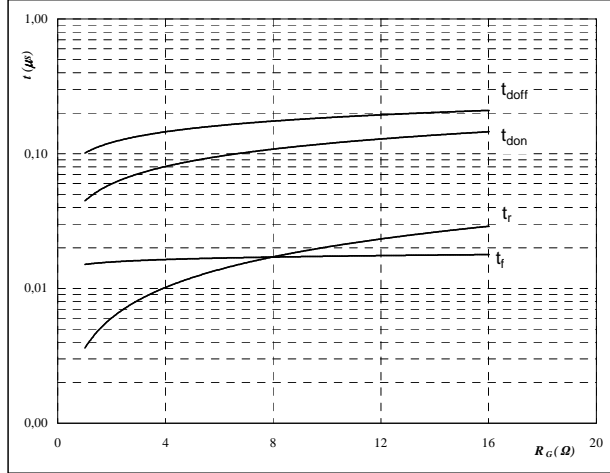

With an inductive load at

$T_j =$	125	°C
$V_{CE} =$	350	V
$V_{GE} =$	±15	V
$I_C =$	35	A

figure 11. FWD

Typical reverse recovery time as a function of collector current

$$t_{rr} = f(I_C)$$

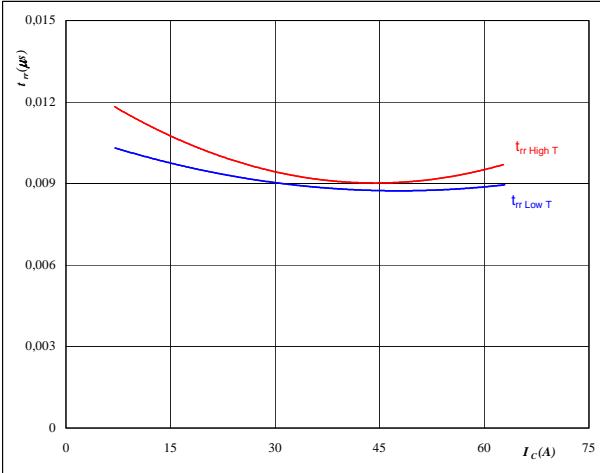

At

$T_j =$	25/125	°C
$V_{CE} =$	350	V
$V_{GE} =$	±15	V
$R_{gon} =$	4	Ω

figure 12. FWD

Typical reverse recovery time as a function of IGBT turn on gate resistor

$$t_{rr} = f(R_{gon})$$

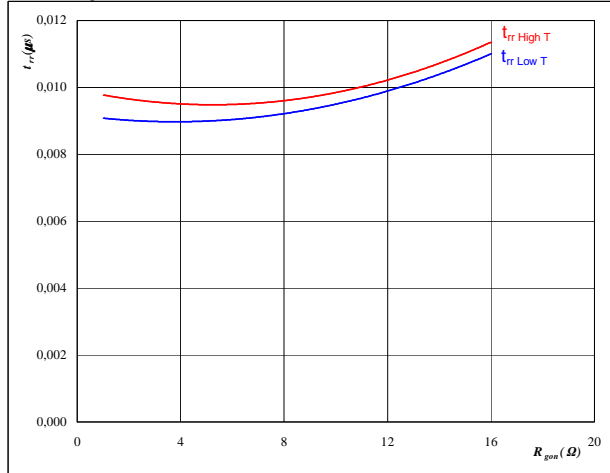

At

$T_j =$	25/125	°C
$V_R =$	350	V
$I_F =$	35	A
$V_{GE} =$	±15	V



Buck

figure 13. FWD

Typical reverse recovery charge as a function of collector current

$Q_{rr} = f(I_c)$

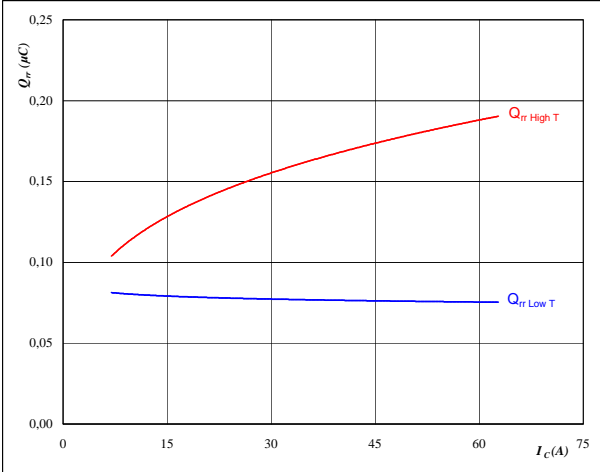

At
 $T_j = 25/125$ °C
 $V_{CE} = 350$ V
 $V_{GE} = \pm 15$ V
 $R_{gon} = 4$ Ω

figure 14. FWD

Typical reverse recovery charge as a function of IGBT turn on gate resistor

$Q_{rr} = f(R_{gon})$

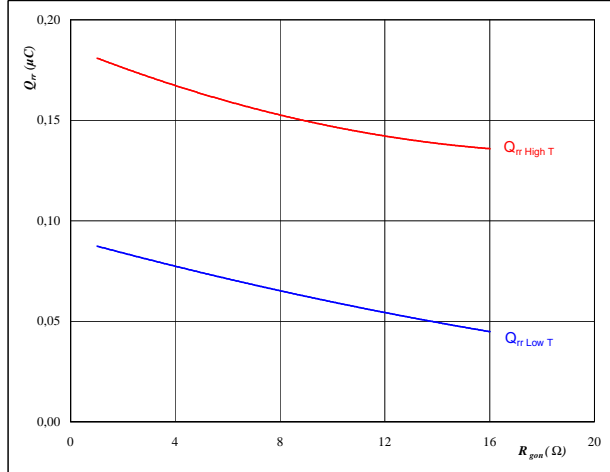

At
 $T_j = 25/125$ °C
 $V_R = 350$ V
 $I_F = 35$ A
 $V_{GE} = \pm 15$ V

figure 15. FWD

Typical reverse recovery current as a function of collector current

$I_{RRM} = f(I_c)$

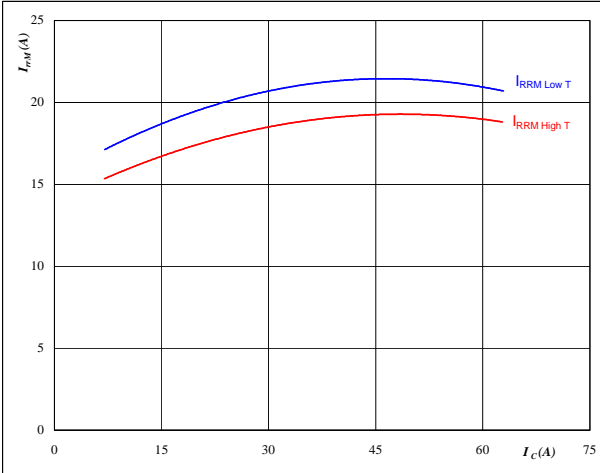

At
 $T_j = 25/125$ °C
 $V_{CE} = 350$ V
 $V_{GE} = \pm 15$ V
 $R_{gon} = 4$ Ω

figure 16. FWD

Typical reverse recovery current as a function of IGBT turn on gate resistor

$I_{RRM} = f(R_{gon})$

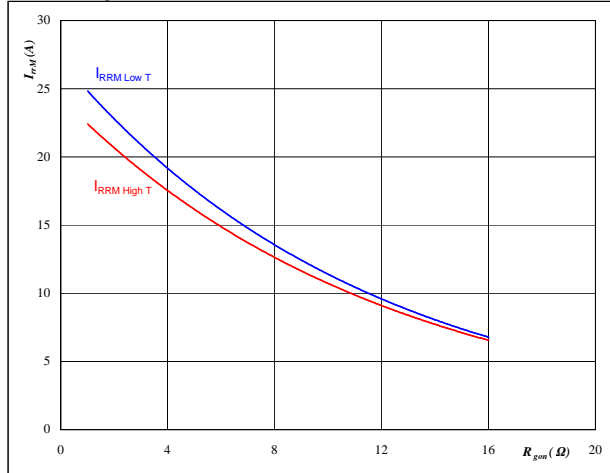

At
 $T_j = 25/125$ °C
 $V_R = 350$ V
 $I_F = 35$ A
 $V_{GE} = \pm 15$ V



Buck

figure 17. FWD

Typical rate of fall of forward and reverse recovery current as a function of collector current

$$dI_0/dt, dI_{rec}/dt = f(I_c)$$

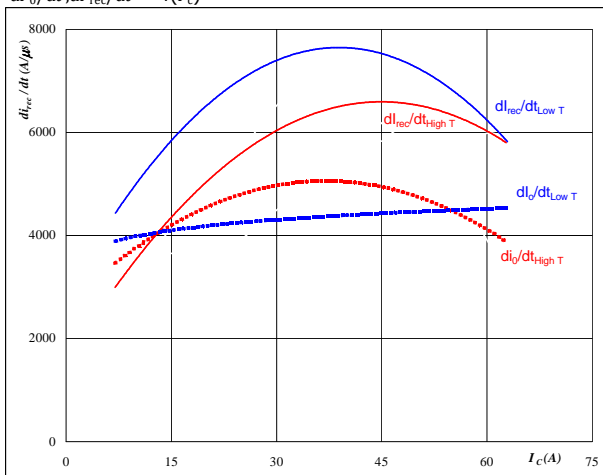

At
 $T_j = 25/125 \text{ } ^\circ\text{C}$
 $V_{CE} = 350 \text{ V}$
 $V_{GE} = \pm 15 \text{ V}$
 $R_{gon} = 4 \text{ } \Omega$

figure 18. FWD

Typical rate of fall of forward and reverse recovery current as a function of IGBT turn on gate resistor

$$dI_0/dt, dI_{rec}/dt = f(R_{gon})$$

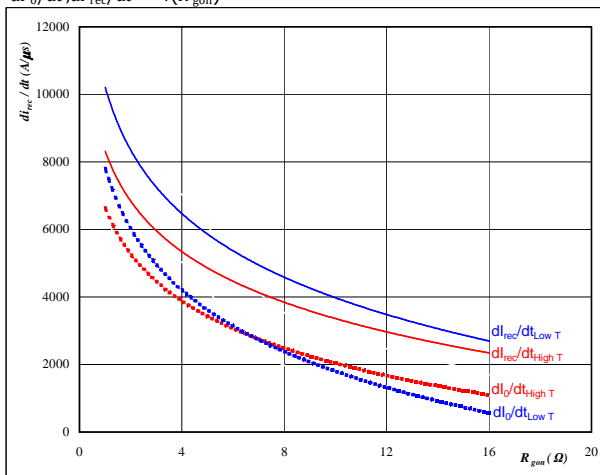

At
 $T_j = 25/125 \text{ } ^\circ\text{C}$
 $V_R = 350 \text{ V}$
 $I_F = 35 \text{ A}$
 $V_{GE} = \pm 15 \text{ V}$

figure 19. IGBT

IGBT transient thermal impedance as a function of pulse width

$$Z_{th(j-s)} = f(t_p)$$

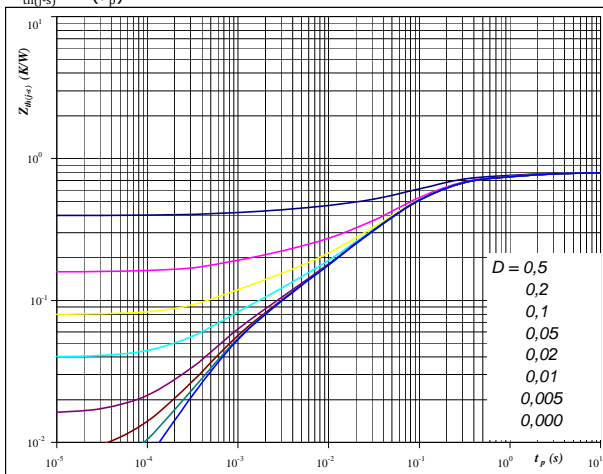

At
 $D = t_p / T$
 $R_{th(j-s)} = 0,80 \text{ K/W}$

IGBT thermal model values

R (K/W)	Tau (s)
6,19E-02	2,26E+00
1,10E-01	4,08E-01
4,12E-01	9,23E-02
1,04E-01	2,31E-02
5,73E-02	5,67E-03
4,98E-02	8,49E-04

figure 20. FWD

FWD transient thermal impedance as a function of pulse width

$$Z_{th(j-s)} = f(t_p)$$

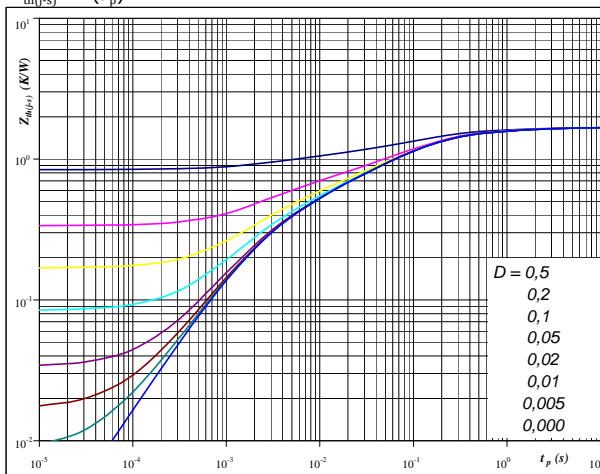

At
 $D = t_p / T$
 $R_{th(j-s)} = 1,68 \text{ K/W}$

FWD thermal model values

R (K/W)	Tau (s)
5,88E-02	4,81E+00
1,68E-01	8,53E-01
6,16E-01	1,45E-01
3,72E-01	3,88E-02
2,69E-01	7,13E-03
1,97E-01	1,68E-03



Buck

figure 21. IGBT

Power dissipation as a function of heatsink temperature

$$P_{tot} = f(T_s)$$

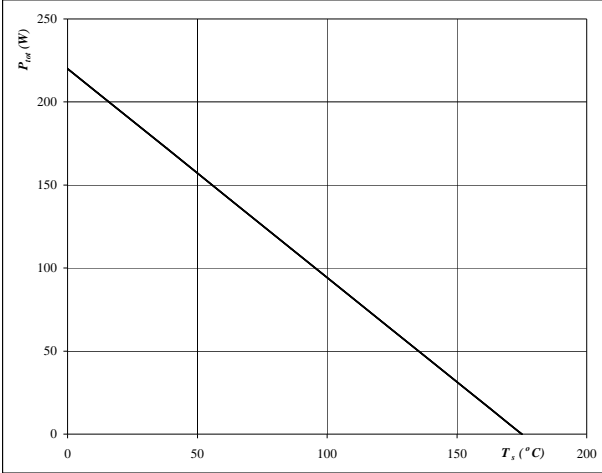

At
T_j = 175 °C

figure 22. IGBT

Collector current as a function of heatsink temperature

$$I_C = f(T_s)$$

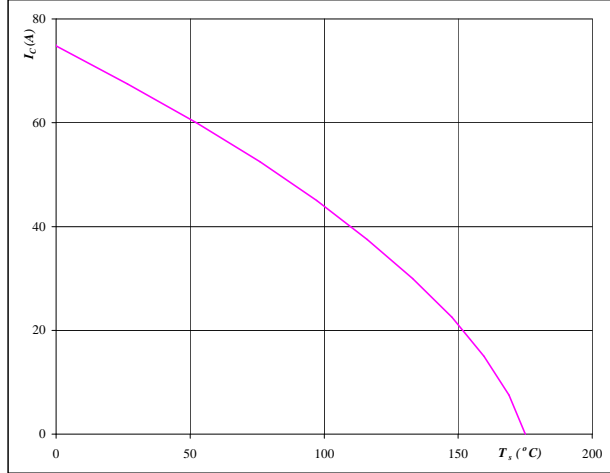

At
T_j = 175 °C
V_{GE} = 15 V

figure 23.. FWD

Power dissipation as a function of heatsink temperature

$$P_{tot} = f(T_s)$$

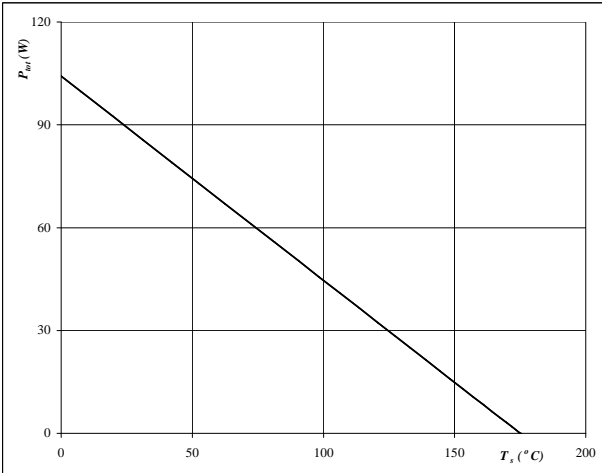

At
T_j = 175 °C

figure 24. FWD

Forward current as a function of heatsink temperature

$$I_F = f(T_s)$$

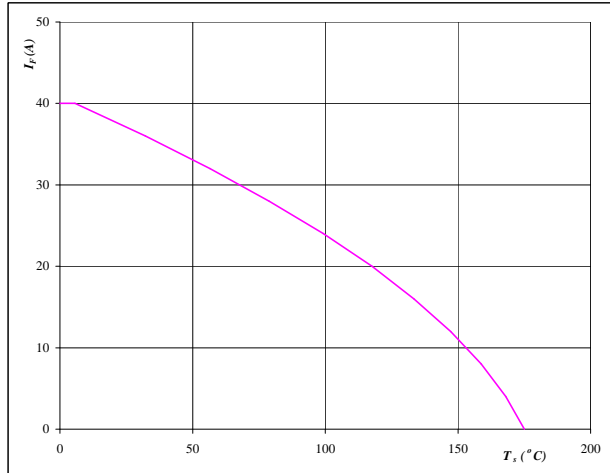

At
T_j = 175 °C



Buck

figure 25. IGBT

Safe operating area as a function of collector-emitter voltage

$I_C = f(V_{CE})$

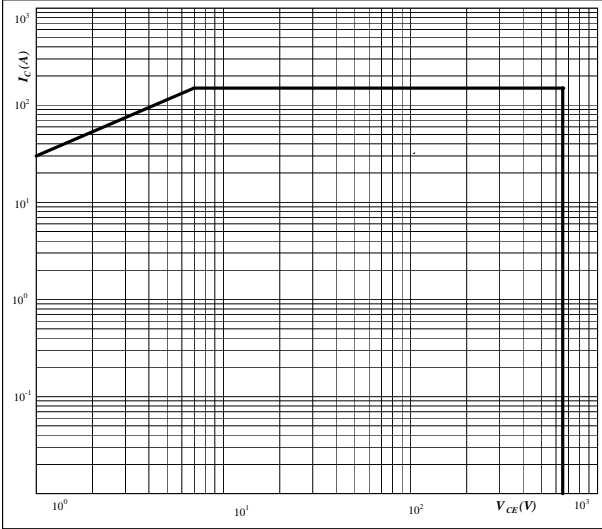

At

$T_j \leq T_{jmax}$

figure 26. IGBT

Gate voltage vs Gate charge

$V_{GE} = f(Q_g)$

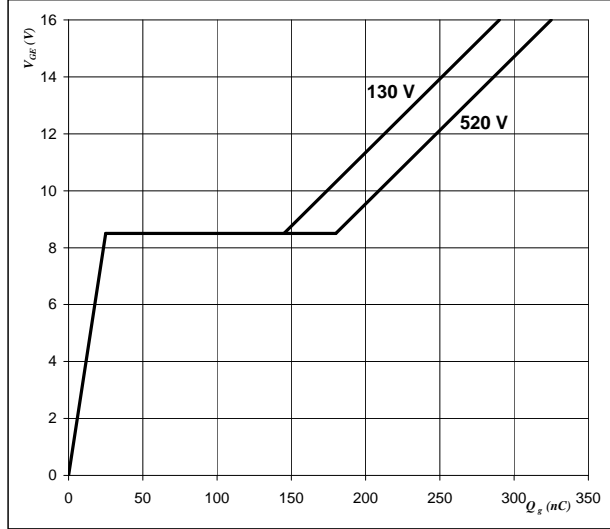

At

$I_C = 50 \text{ A}$



Boost

figure 1. IGBT

Typical output characteristics

$I_C = f(V_{CE})$

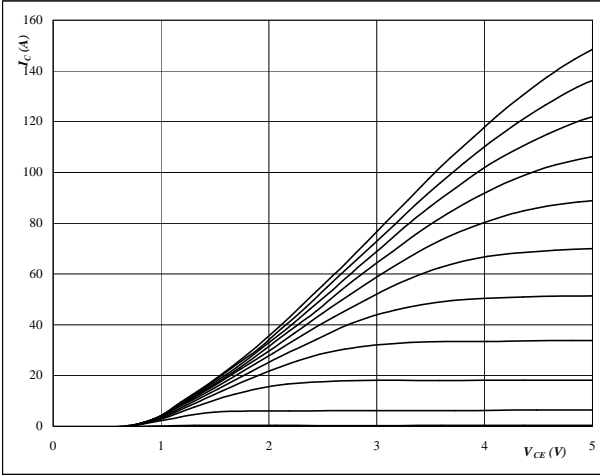

At

$t_p = 250 \mu s$
 $T_j = 25 \text{ } ^\circ C$
 V_{GE} from 7 V to 17 V in steps of 1 V

figure 2. IGBT

Typical output characteristics

$I_C = f(V_{CE})$

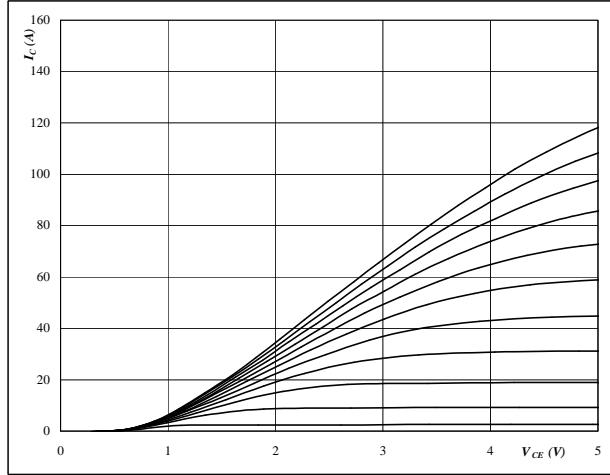

At

$t_p = 250 \mu s$
 $T_j = 125 \text{ } ^\circ C$
 V_{GE} from 7 V to 17 V in steps of 1 V

figure 3. IGBT

Typical transfer characteristics

$I_C = f(V_{GE})$

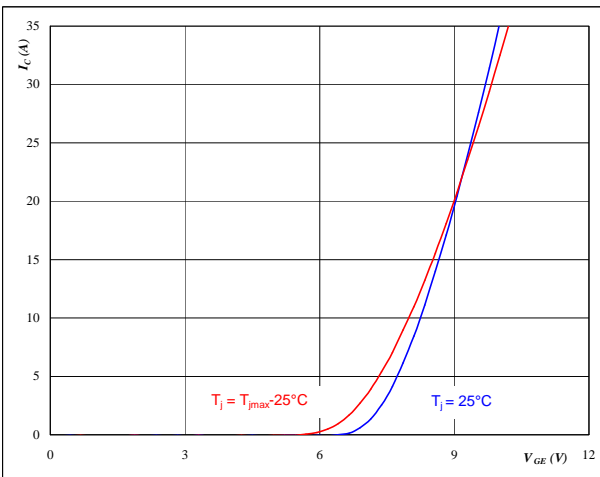

At

$t_p = 250 \mu s$
 $V_{CE} = 10 V$

figure 4. FWD

Typical diode forward current as a function of forward voltage

$I_F = f(V_F)$

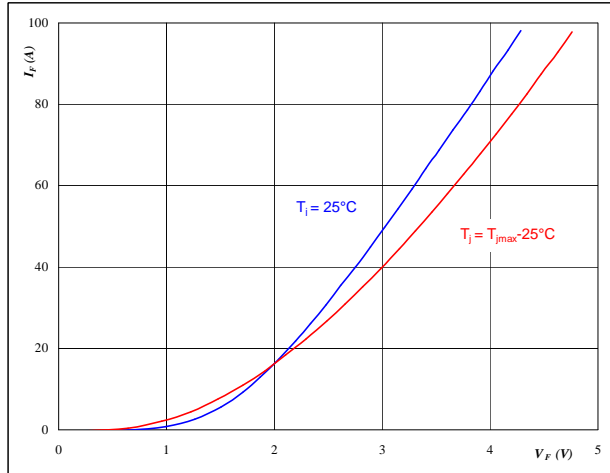

At

$t_p = 250 \mu s$



Boost

figure 5. IGBT

Typical switching energy losses as a function of collector current

$E = f(I_C)$

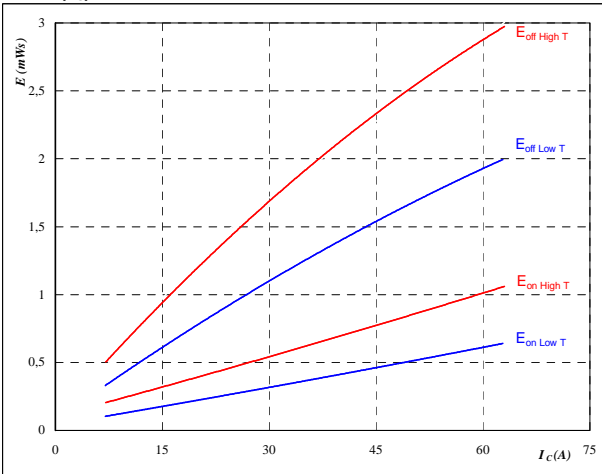

With an inductive load at

- $T_j = 25/125 \text{ } ^\circ\text{C}$
- $V_{CE} = 350 \text{ V}$
- $V_{GE} = \pm 15 \text{ V}$
- $R_{gon} = 4 \text{ } \Omega$
- $R_{goff} = 4 \text{ } \Omega$

figure 6. IGBT

Typical switching energy losses as a function of gate resistor

$E = f(R_G)$

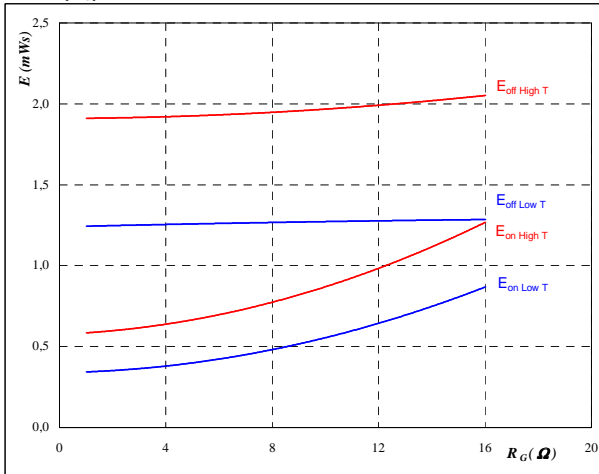

With an inductive load at

- $T_j = 25/125 \text{ } ^\circ\text{C}$
- $V_{CE} = 350 \text{ V}$
- $V_{GE} = \pm 15 \text{ V}$
- $I_C = 35 \text{ A}$

figure 7. FWD

Typical reverse recovery energy loss as a function of collector current

$E_{rec} = f(I_C)$

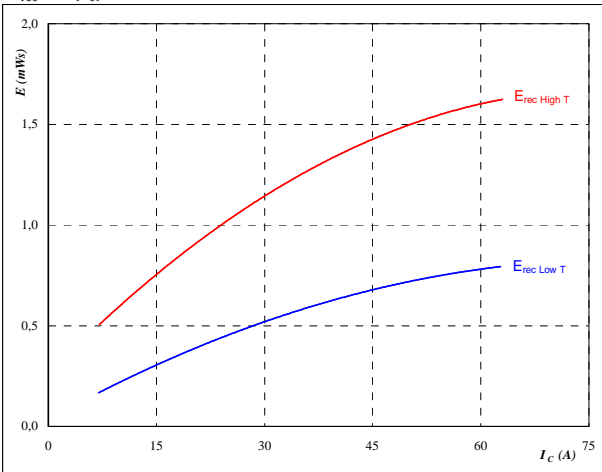

With an inductive load at

- $T_j = 25/125 \text{ } ^\circ\text{C}$
- $V_{CE} = 350 \text{ V}$
- $V_{GE} = \pm 15 \text{ V}$
- $R_{gon} = 4 \text{ } \Omega$

figure 8. FWD

Typical reverse recovery energy loss as a function of gate resistor

$E_{rec} = f(R_G)$

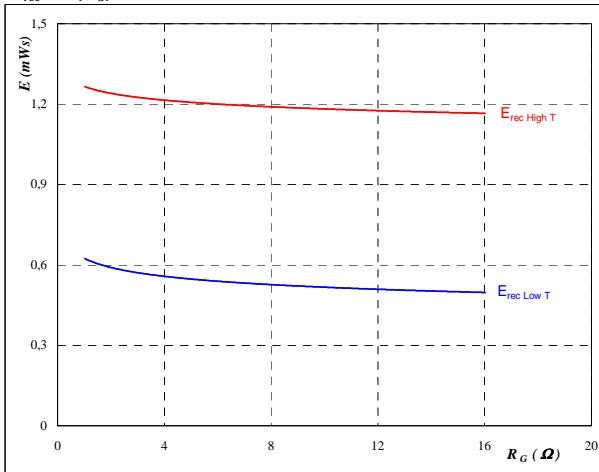

With an inductive load at

- $T_j = 25/125 \text{ } ^\circ\text{C}$
- $V_{CE} = 350 \text{ V}$
- $V_{GE} = \pm 15 \text{ V}$
- $I_C = 35 \text{ A}$



Boost

figure 9. IGBT

Typical switching times as a function of collector current

$$t = f(I_C)$$

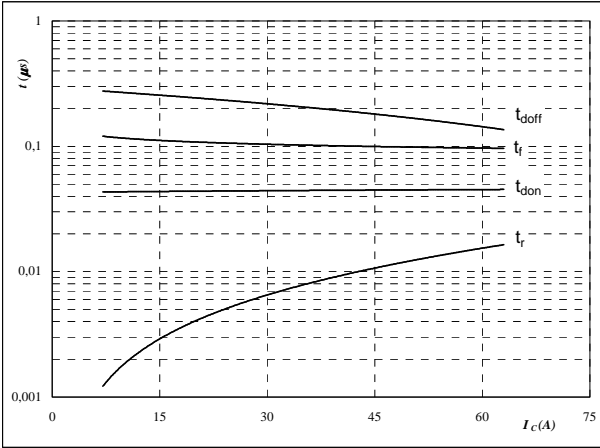

With an inductive load at

$T_j =$	125	°C
$V_{CE} =$	350	V
$V_{GE} =$	±15	V
$R_{gon} =$	4	Ω
$R_{goff} =$	4	Ω

figure 10. IGBT

Typical switching times as a function of gate resistor

$$t = f(R_G)$$

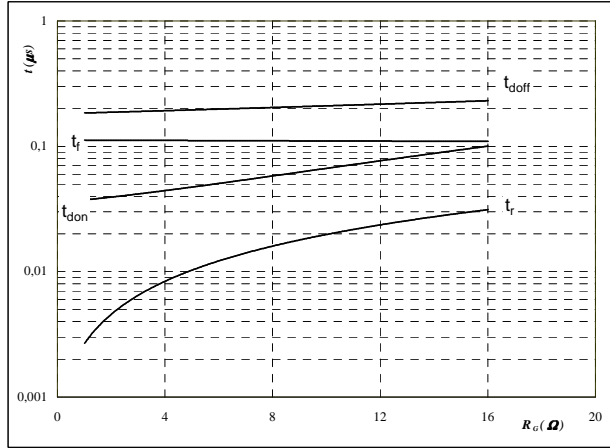

With an inductive load at

$T_j =$	125	°C
$V_{CE} =$	350	V
$V_{GE} =$	±15	V
$I_C =$	35	A

figure 11. FWD

Typical reverse recovery time as a function of collector current

$$t_{rr} = f(I_C)$$

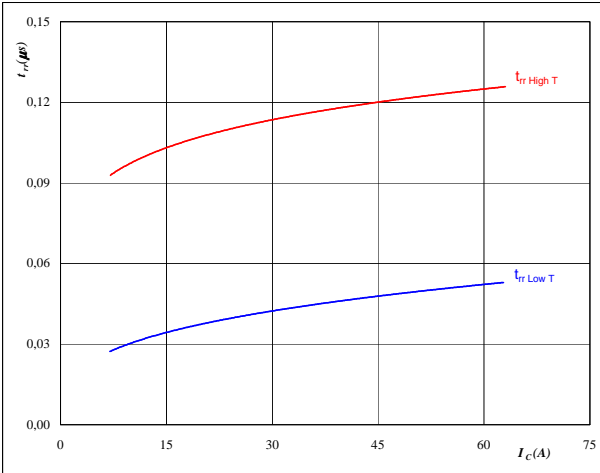

At

$T_j =$	25/125	°C
$V_{CE} =$	350	V
$V_{GE} =$	±15	V
$R_{gon} =$	4	Ω

figure 12. FWD

Typical reverse recovery time as a function of IGBT turn on gate resistor

$$t_{rr} = f(R_{gon})$$

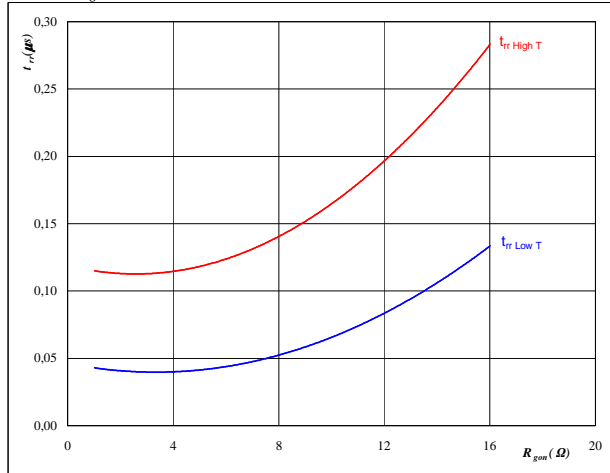

At

$T_j =$	25/125	°C
$V_R =$	350	V
$I_F =$	35	A
$V_{GE} =$	±15	V



Boost

figure 13. FWD

Typical reverse recovery charge as a function of collector current

$$Q_{rr} = f(I_c)$$

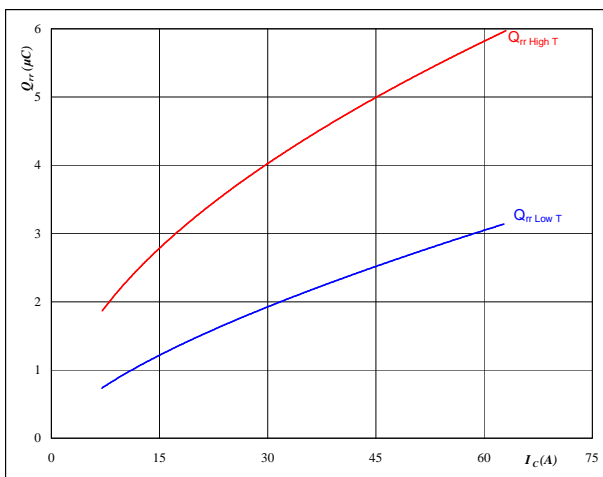

At

$T_j =$	25/125	°C
$V_{CE} =$	350	V
$V_{GE} =$	±15	V
$R_{gon} =$	4	Ω

figure 14. FWD

Typical reverse recovery charge as a function of IGBT turn on gate resistor

$$Q_{rr} = f(R_{gon})$$

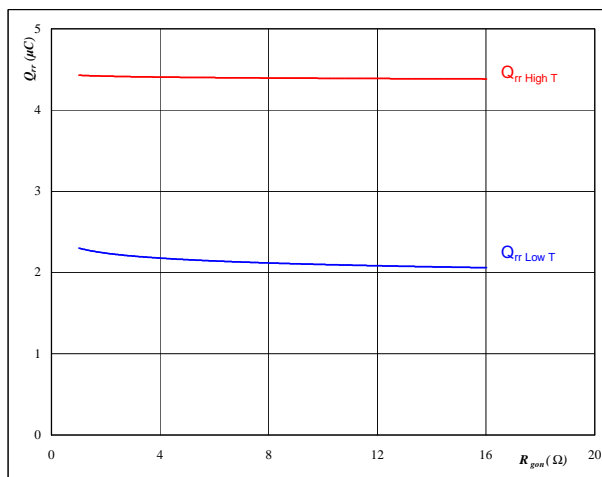

At

$T_j =$	25/125	°C
$V_R =$	350	V
$I_F =$	35	A
$V_{GE} =$	±15	V

figure 15. FWD

Typical reverse recovery current as a function of collector current

$$I_{RRM} = f(I_c)$$

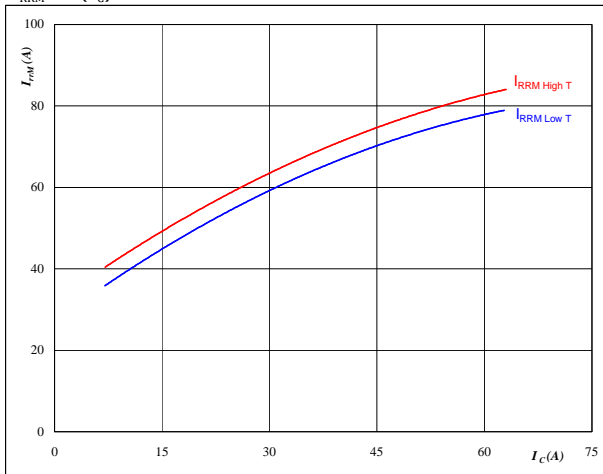

At

$T_j =$	25/125	°C
$V_{CE} =$	350	V
$V_{GE} =$	±15	V
$R_{gon} =$	4	Ω

figure 16. FWD

Typical reverse recovery current as a function of IGBT turn on gate resistor

$$I_{RRM} = f(R_{gon})$$

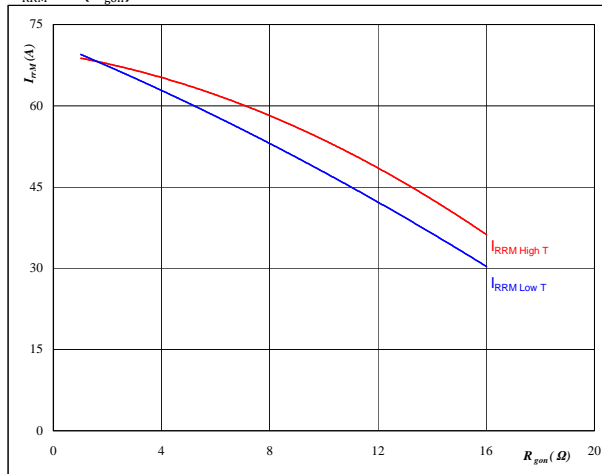

At

$T_j =$	25/125	°C
$V_R =$	350	V
$I_F =$	35	A
$V_{GE} =$	±15	V



Boost

figure 17. FWD

Typical rate of fall of forward and reverse recovery current as a function of collector current

$$di_0/dt, di_{rec}/dt = f(I_c)$$

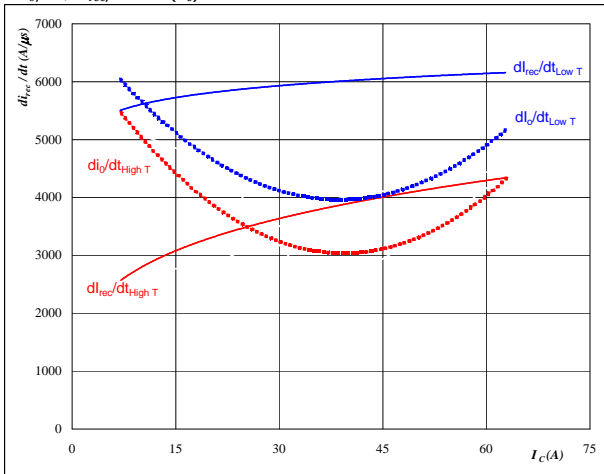

At
 $T_j = 25/125 \text{ } ^\circ\text{C}$
 $V_{CE} = 350 \text{ V}$
 $V_{GE} = \pm 15 \text{ V}$
 $R_{gon} = 4 \text{ } \Omega$

figure 18. FWD

Typical rate of fall of forward and reverse recovery current as a function of IGBT turn on gate resistor

$$di_0/dt, di_{rec}/dt = f(R_{gon})$$

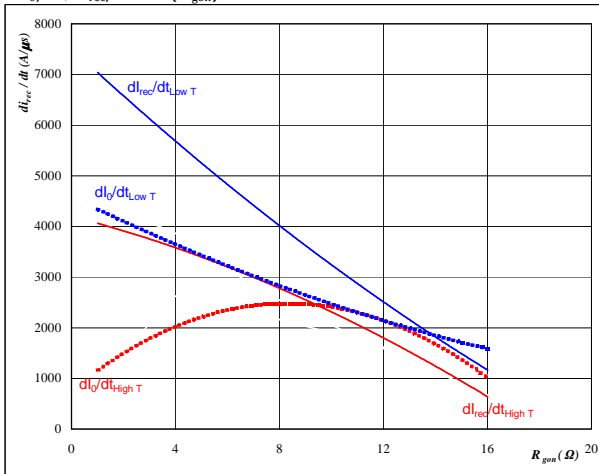

At
 $T_j = 25/125 \text{ } ^\circ\text{C}$
 $V_R = 350 \text{ V}$
 $I_F = 35 \text{ A}$
 $V_{GE} = \pm 15 \text{ V}$

figure 19. IGBT

IGBT transient thermal impedance as a function of pulse width

$$Z_{th(j-s)} = f(t_p)$$

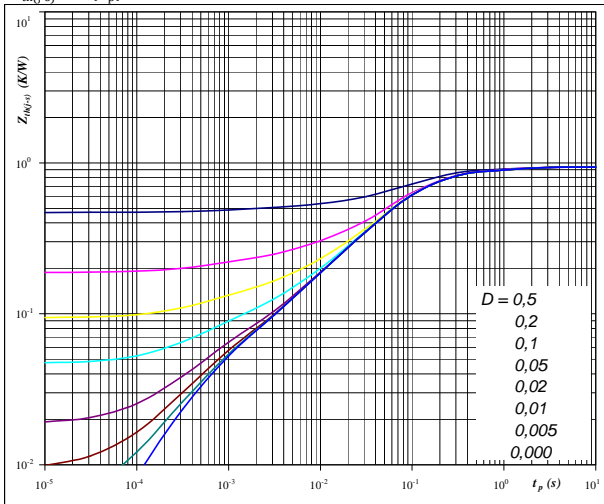

At
 $D = t_p / T$
 $R_{th(j-s)} = 0,94 \text{ K/W}$

IGBT thermal model values

R (K/W)	Tau (s)
1,15E-01	9,47E-01
4,15E-01	1,24E-01
2,99E-01	4,81E-02
7,22E-02	5,86E-03
3,82E-02	5,62E-04

figure 20. FWD

FWD transient thermal impedance as a function of pulse width

$$Z_{th(j-s)} = f(t_p)$$

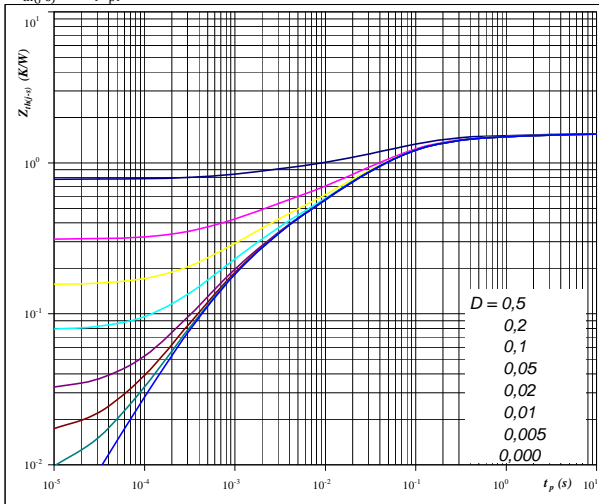

At
 $D = t_p / T$
 $R_{th(j-s)} = 1,56 \text{ K/W}$

FWD thermal model values

R (K/W)	Tau (s)
4,65E-02	4,86E+00
1,06E-01	8,11E-01
4,71E-01	1,09E-01
4,83E-01	3,07E-02
2,34E-01	7,03E-03
1,81E-01	1,25E-03



Boost

figure 21. IGBT

Power dissipation as a function of heatsink temperature

$$P_{tot} = f(T_s)$$

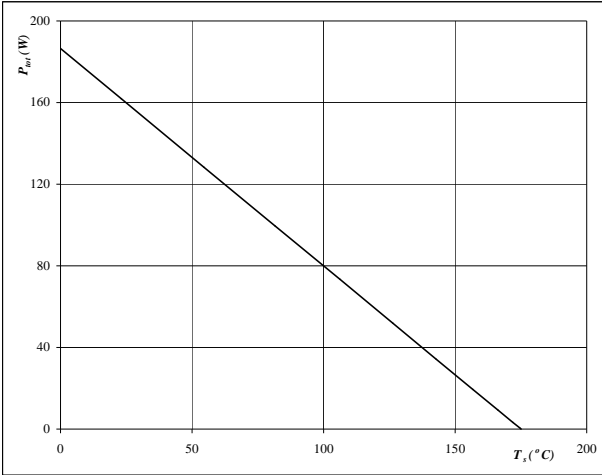

At
T_j = 175 °C

figure 22. IGBT

Collector current as a function of heatsink temperature

$$I_C = f(T_s)$$

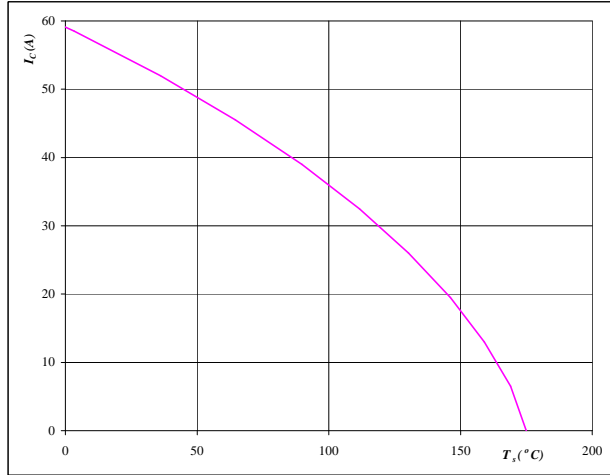

At
T_j = 175 °C
V_{GE} = 15 V

figure 23. FWD

Power dissipation as a function of heatsink temperature

$$P_{tot} = f(T_s)$$

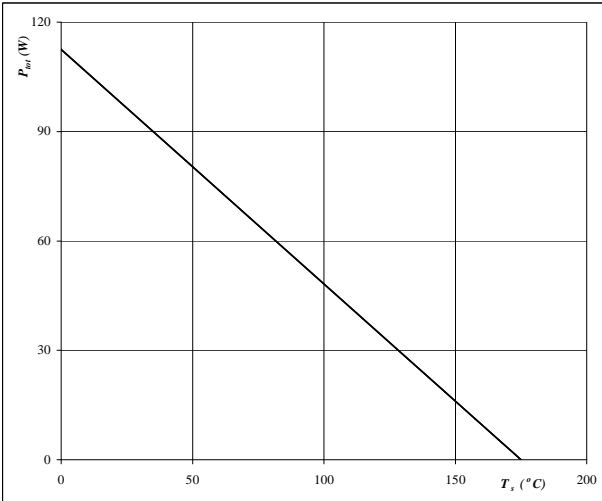

At
T_j = 175 °C

figure 24. FWD

Forward current as a function of heatsink temperature

$$I_F = f(T_s)$$

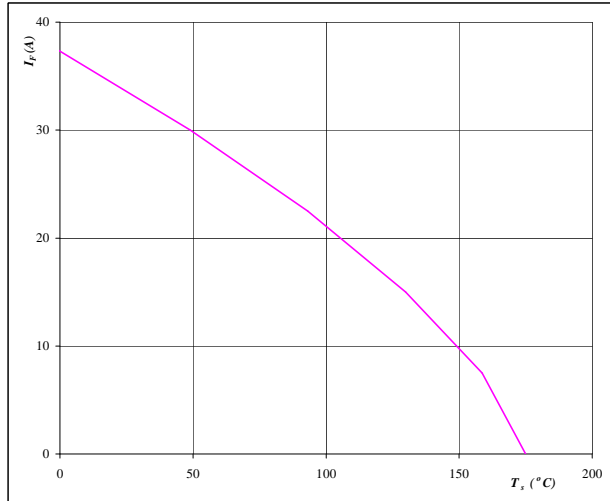

At
T_j = 175 °C



Boost Sw. Protection Diode

figure 25. Boost Sw. Protection Diode

Typical diode forward current as a function of forward voltage

$I_F = f(V_F)$

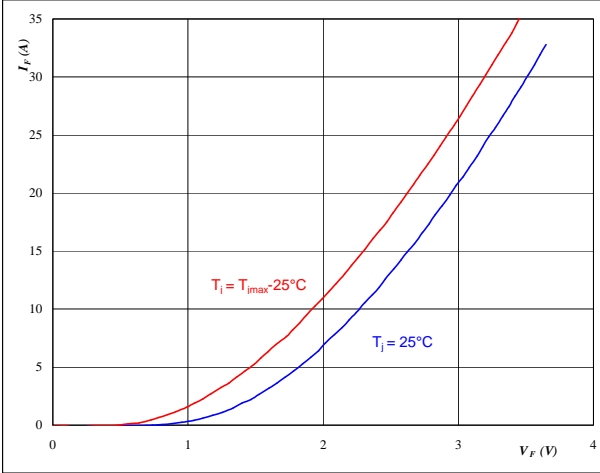

At
 $t_p = 250 \mu s$

figure 26. Boost Sw. Protection Diode

Diode transient thermal impedance as a function of pulse width

$Z_{th(j-s)} = f(t_p)$

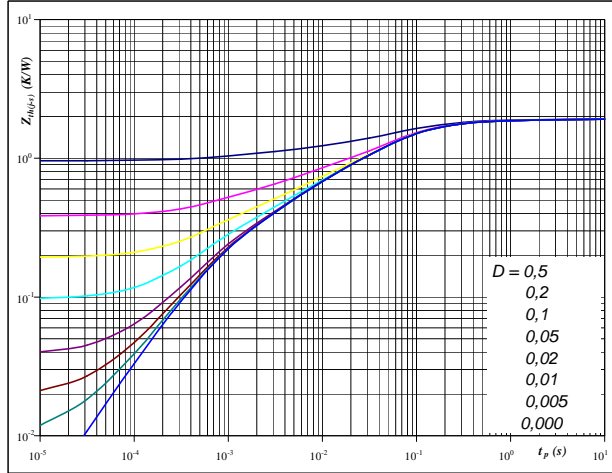

At
 $D = t_p / T$
 $R_{th(j-s)} = 1,92 \text{ K/W}$

figure 27. Boost Sw. Protection Diode

Power dissipation as a function of heatsink temperature

$P_{tot} = f(T_s)$

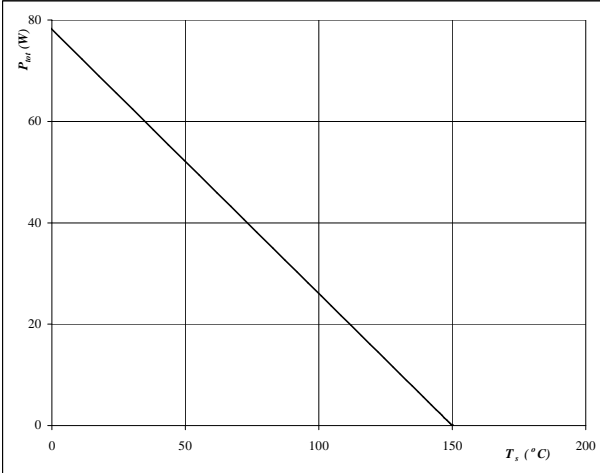

At
 $T_j = 150 \text{ °C}$

figure 28. Boost Sw. Protection Diode

Forward current as a function of heatsink temperature

$I_F = f(T_s)$

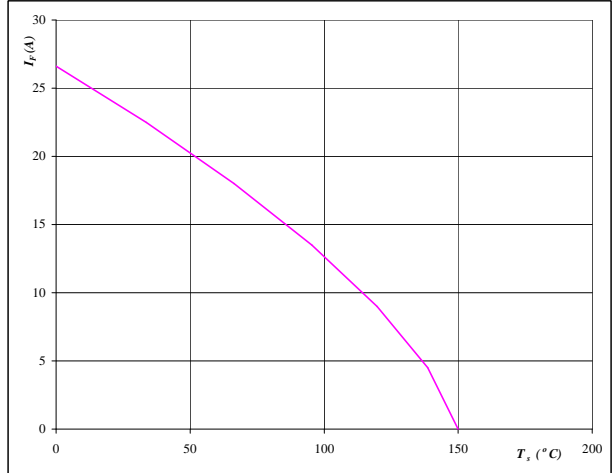

At
 $T_j = 150 \text{ °C}$



Buck Sw. Protection Diode

figure 1. Buck Sw. Protection Diode

Typical diode forward current as a function of forward voltage

$I_F = f(V_F)$

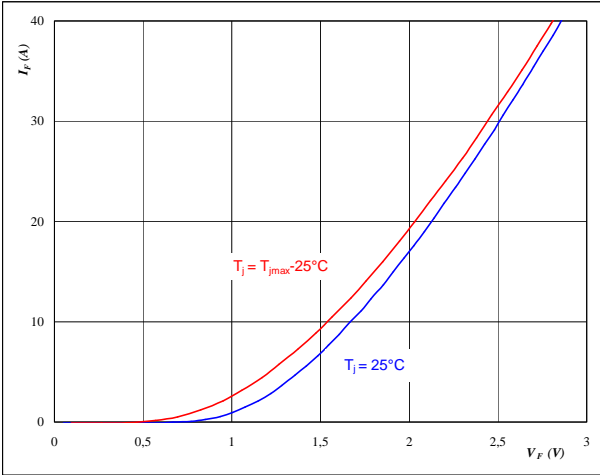

At
 $t_p = 250 \mu s$

figure 2. Buck Sw. Protection Diode

Diode transient thermal impedance as a function of pulse width

$Z_{th(j-s)} = f(t_p)$

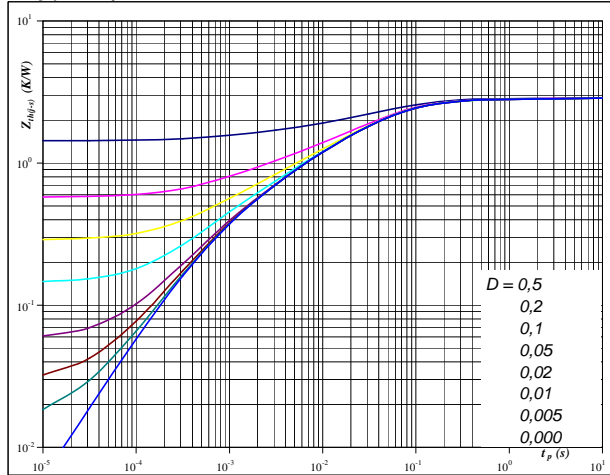

At
 $D = t_p / T$
 $R_{th(j-s)} = 2,87 K/W$

figure 3. Buck Sw. Protection Diode

Power dissipation as a function of heatsink temperature

$P_{tot} = f(T_s)$

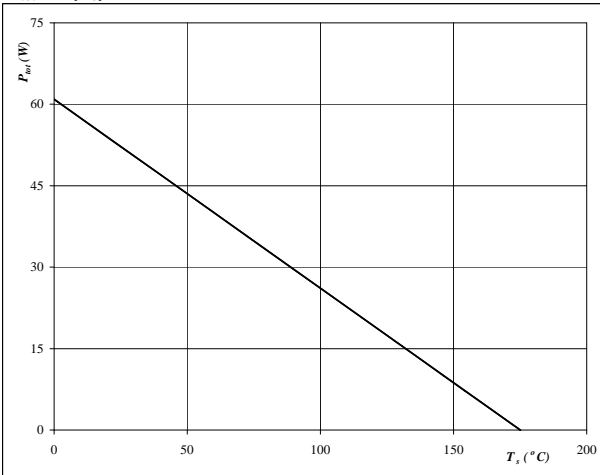

At
 $T_j = 175 °C$

figure 4. Buck Sw. Protection Diode

Forward current as a function of heatsink temperature

$I_F = f(T_s)$

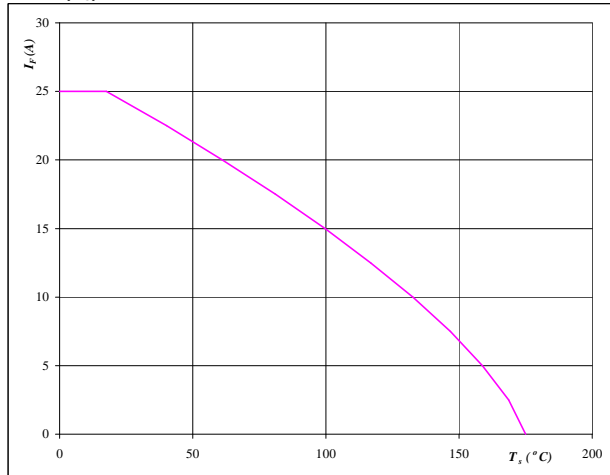

At
 $T_j = 175 °C$



Thermistor

figure 1. Thermistor

**Typical NTC characteristic
as a function of temperature**

$$R_T = f(T)$$

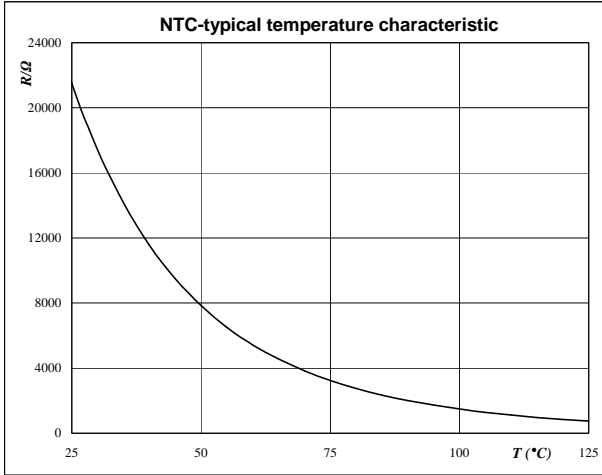



Switching Definitions BOOST

General conditions

T_j	=	125 °C
R_{gon}	=	4 Ω
R_{goff}	=	4 Ω

figure 1. BOOST IGBT

Turn-off Switching Waveforms & definition of t_{doff} , t_{Eoff}
(t_{Eoff} = integrating time for E_{off})

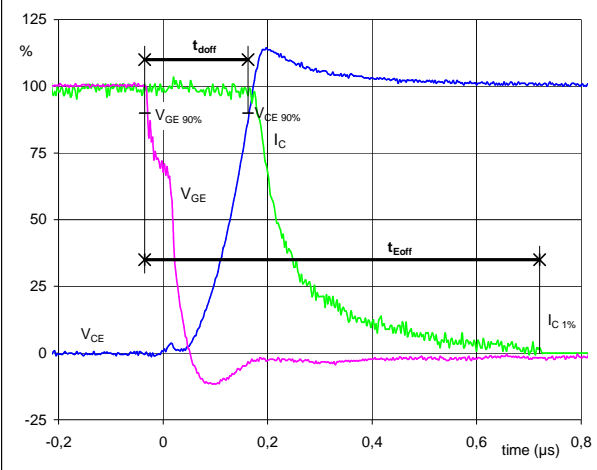

V_{GE} (0%) =	-15	V
V_{GE} (100%) =	15	V
V_C (100%) =	350	V
I_C (100%) =	35	A
t_{doff} =	0,19	μs
t_{Eoff} =	0,76	μs

figure 2. BOOST IGBT

Turn-on Switching Waveforms & definition of t_{don} , t_{Eon}
(t_{Eon} = integrating time for E_{on})

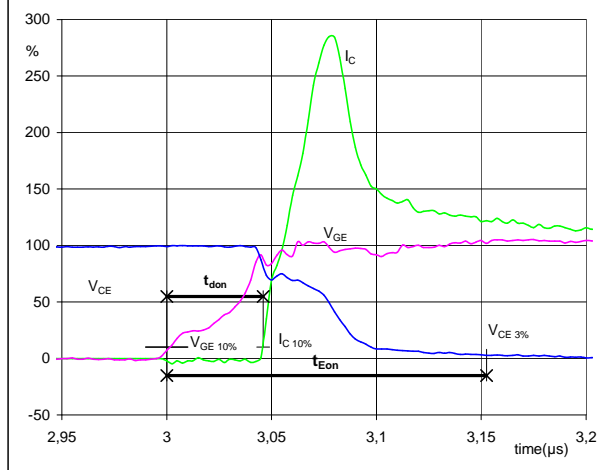

V_{GE} (0%) =	-15	V
V_{GE} (100%) =	15	V
V_C (100%) =	350	V
I_C (100%) =	35	A
t_{don} =	0,05	μs
t_{Eon} =	0,15	μs

figure 3. BOOST IGBT

Turn-off Switching Waveforms & definition of t_f

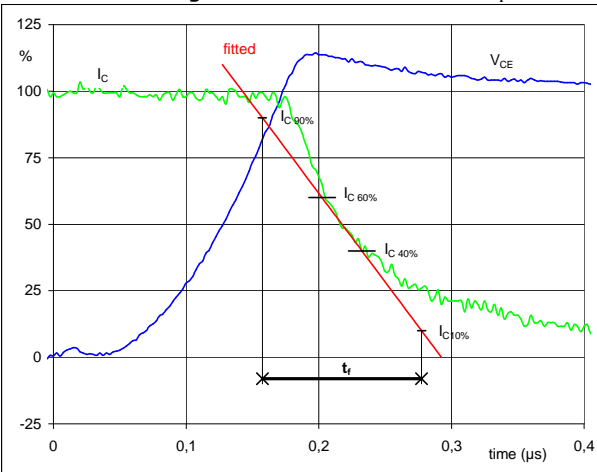

V_C (100%) =	350	V
I_C (100%) =	35	A
t_f =	0,11	μs

figure 4. BOOST IGBT

Turn-on Switching Waveforms & definition of t_r

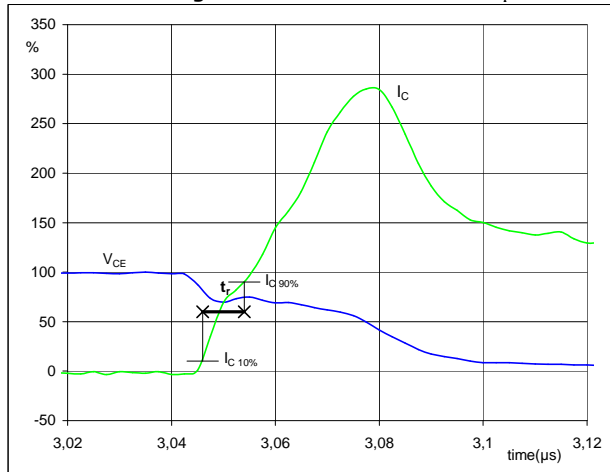

V_C (100%) =	350	V
I_C (100%) =	35	A
t_r =	0,01	μs



Switching Definitions BOOST

figure 5. BOOST IGBT
Turn-off Switching Waveforms & definition of t_{Eoff}

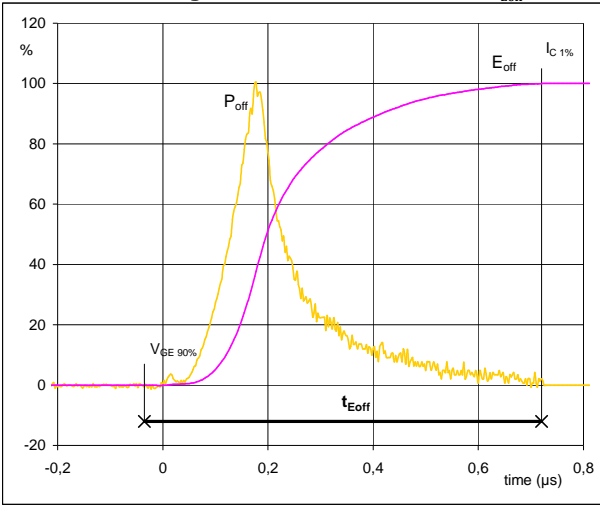

$P_{off} (100\%) = 12,36 \text{ kW}$
 $E_{off} (100\%) = 1,93 \text{ mJ}$
 $t_{Eoff} = 0,76 \text{ }\mu\text{s}$

figure 6. BOOST IGBT
Turn-on Switching Waveforms & definition of t_{Eon}

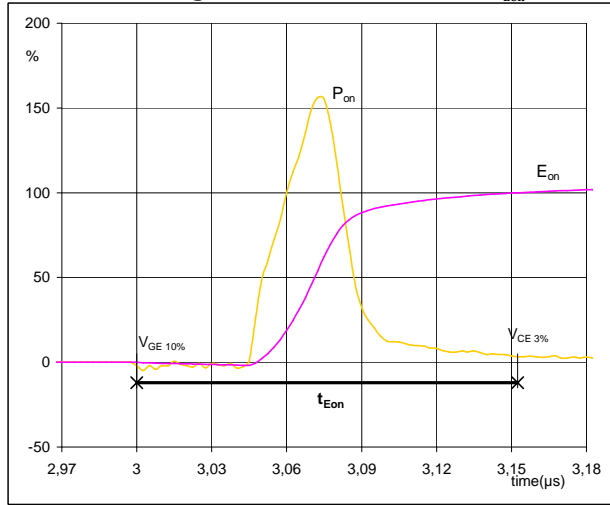

$P_{on} (100\%) = 12,36 \text{ kW}$
 $E_{on} (100\%) = 0,63 \text{ mJ}$
 $t_{Eon} = 0,15 \text{ }\mu\text{s}$

figure 7. BOOST FWD
Turn-off Switching Waveforms & definition of t_{rr}

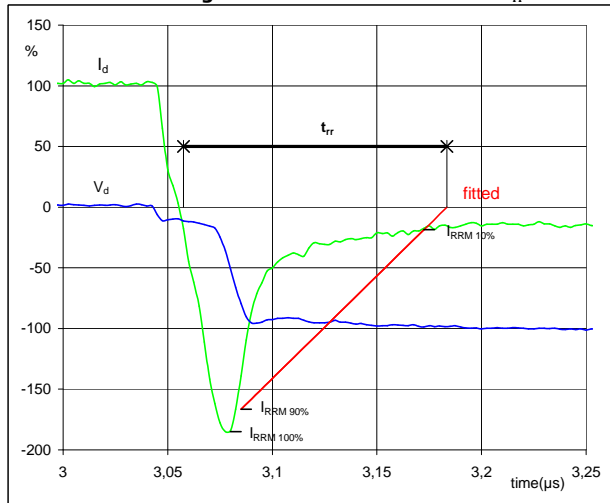

$V_d (100\%) = 350 \text{ V}$
 $I_d (100\%) = 35 \text{ A}$
 $I_{RRM} (100\%) = -67 \text{ A}$
 $t_{rr} = 0,12 \text{ }\mu\text{s}$



Switching Definitions BOOST

figure 8. BOOST IGBT

Turn-on Switching Waveforms & definition of t_{Qrr}
(t_{Qrr} = integrating time for Q_{rr})

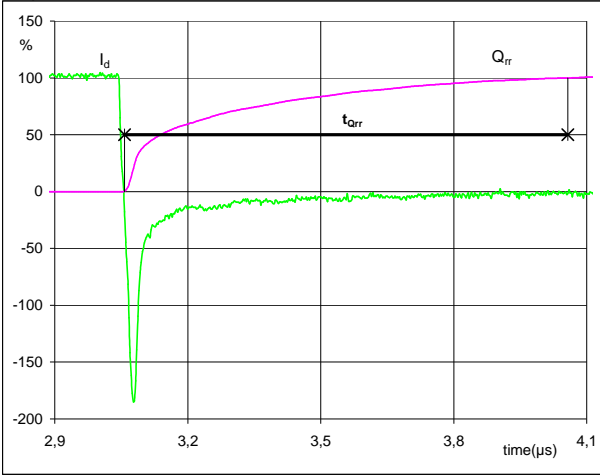

I_d (100%) =	35	A
Q_{rr} (100%) =	4,25	μC
t_{Qrr} =	1,00	μs

figure 9. BOOST IGBT

Turn-on Switching Waveforms & definition of t_{Erec}
(t_{Erec} = integrating time for E_{rec})

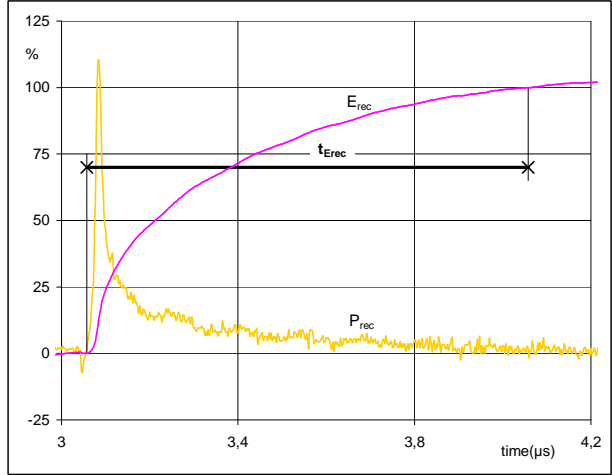

P_{rec} (100%) =	12,36	kW
E_{rec} (100%) =	1,18	mJ
t_{Erec} =	1,00	μs

Measurement circuits

figure 10.

BUCK stage switching measurement circuit

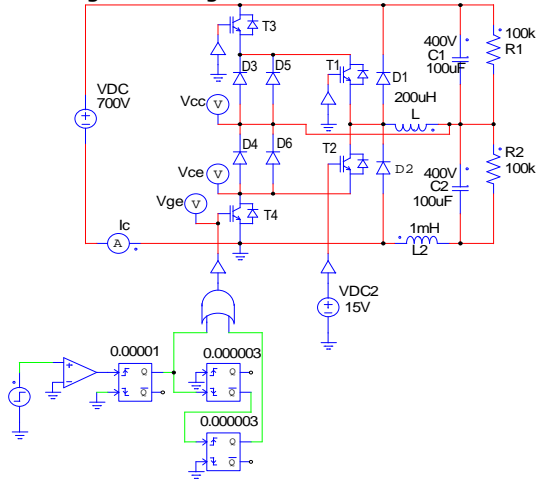
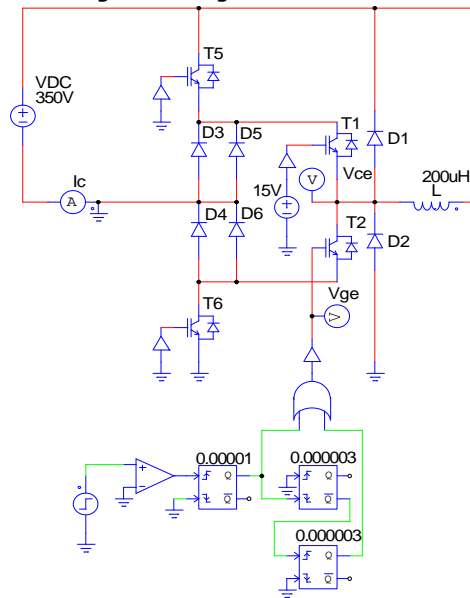

figure 11.

BOOST stage switching measurement circuit





Switching Definitions BUCK

General conditions

T_j	=	125 °C
R_{gon}	=	4 Ω
R_{goff}	=	4 Ω

figure 1. BUCK IGBT

Turn-off Switching Waveforms & definition of t_{doff} , t_{Eoff}
(t_{Eoff} = integrating time for E_{off})

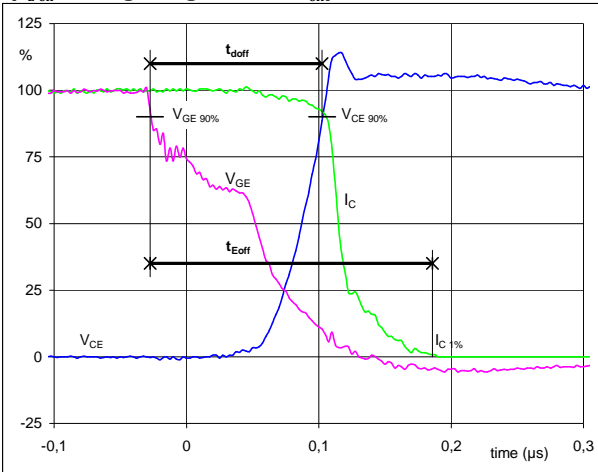

V_{GE} (0%) =	-15	V
V_{GE} (100%) =	15	V
V_C (100%) =	350	V
I_C (100%) =	35	A
t_{doff} =	0,13	μs
t_{Eoff} =	0,21	μs

figure 2. BUCK IGBT

Turn-on Switching Waveforms & definition of t_{donr} , t_{Eon}
(t_{Eon} = integrating time for E_{on})

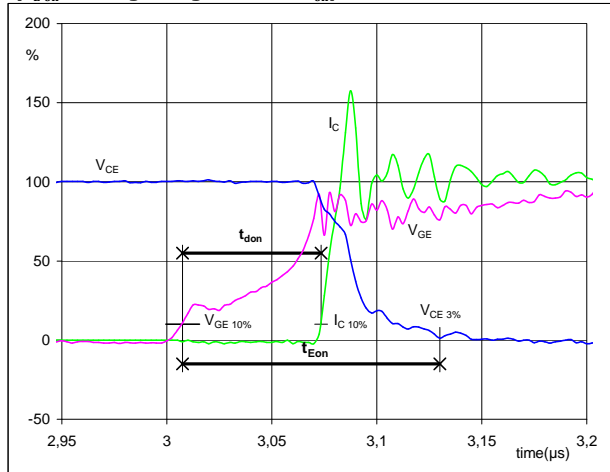

V_{GE} (0%) =	-15	V
V_{GE} (100%) =	15	V
V_C (100%) =	350	V
I_C (100%) =	35	A
t_{donr} =	0,07	μs
t_{Eon} =	0,12	μs

figure 3. BUCK IGBT

Turn-off Switching Waveforms & definition of t_f

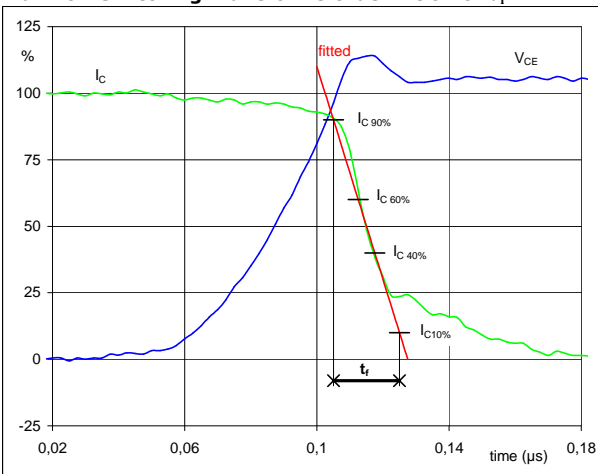

V_C (100%) =	350	V
I_C (100%) =	35	A
t_f =	0,02	μs

figure 4. BUCK IGBT

Turn-on Switching Waveforms & definition of t_r

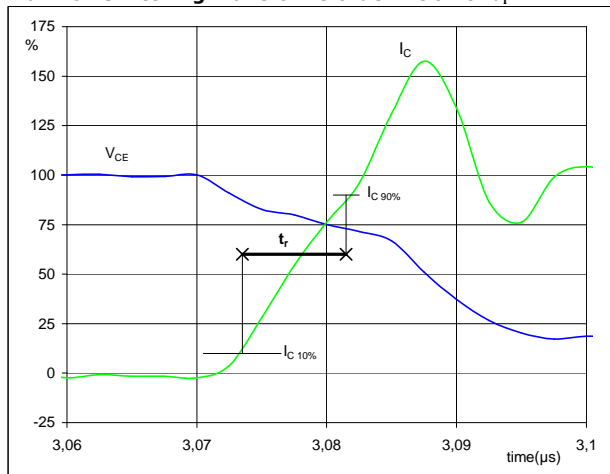

V_C (100%) =	350	V
I_C (100%) =	35	A
t_r =	0,01	μs



Switching Definitions BUCK

figure 5. BUCK IGBT
Turn-off Switching Waveforms & definition of t_{Eoff}

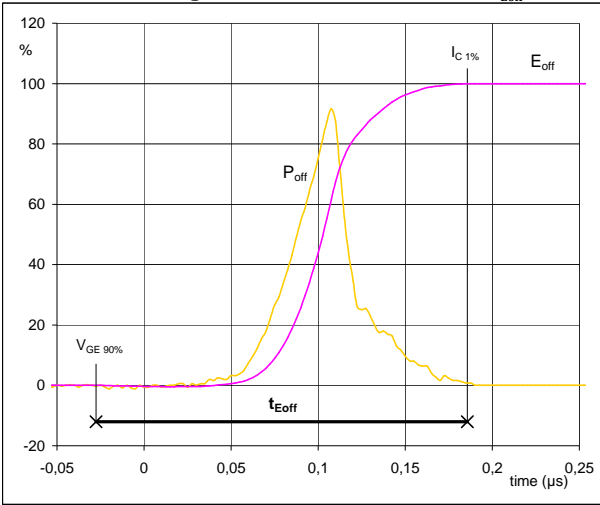

$P_{off} (100\%) = 12,32 \text{ kW}$
 $E_{off} (100\%) = 0,46 \text{ mJ}$
 $t_{Eoff} = 0,21 \text{ µs}$

figure 6. BUCK IGBT
Turn-on Switching Waveforms & definition of t_{Eon}

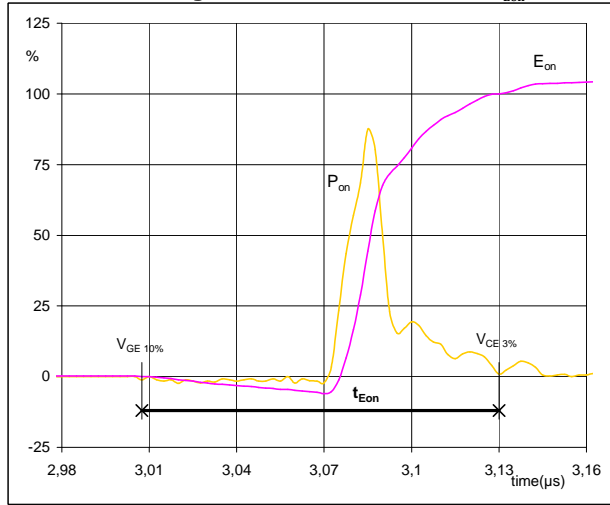

$P_{on} (100\%) = 12,32 \text{ kW}$
 $E_{on} (100\%) = 0,18 \text{ mJ}$
 $t_{Eon} = 0,12 \text{ µs}$

figure 7. BUCK FWD
Turn-off Switching Waveforms & definition of t_{rr}

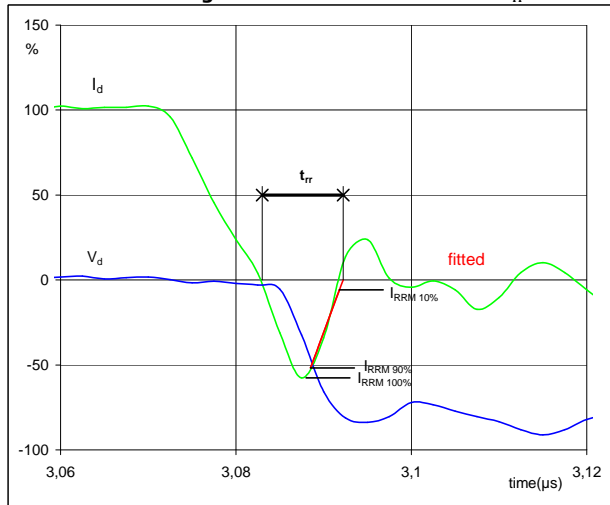

$V_d (100\%) = 350 \text{ V}$
 $I_d (100\%) = 35 \text{ A}$
 $I_{RRM} (100\%) = -20 \text{ A}$
 $t_{rr} = 0,01 \text{ µs}$



Switching Definitions BUCK

figure 8. BUCK IGBT
Turn-on Switching Waveforms & definition of t_{Qrr}
(t_{Qrr} = integrating time for Q_{rr})

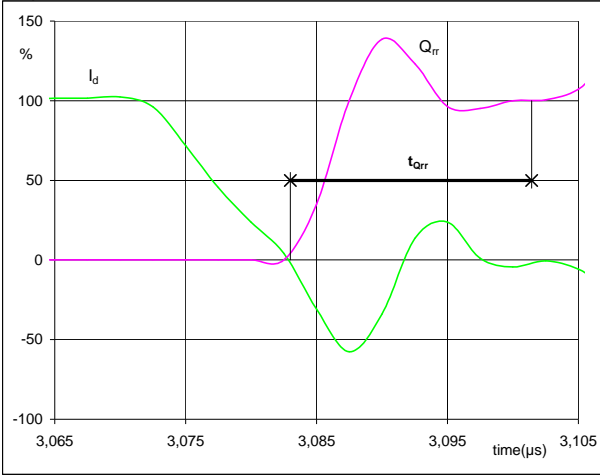

I_d (100%) =	35	A
Q_{rr} (100%) =	0,17	μC
t_{Qrr} =	0,02	μs

figure 9. BUCK IGBT
Turn-on Switching Waveforms & definition of t_{Erec}
(t_{Erec} = integrating time for E_{rec})

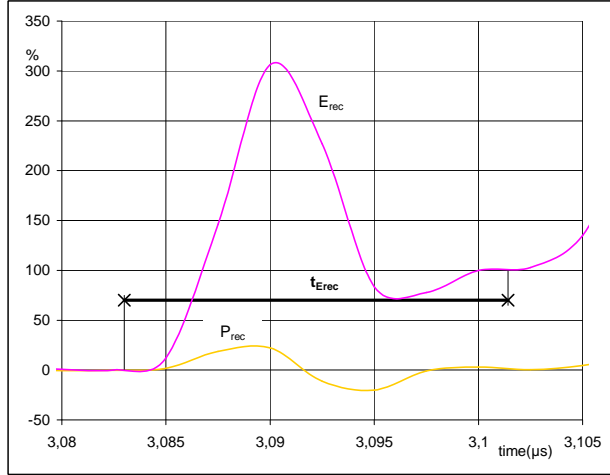

P_{rec} (100%) =	12,32	kW
E_{rec} (100%) =	0,03	mJ
t_{Erec} =	0,02	μs

Measurement circuits

figure 10. BUCK stage switching measurement circuit

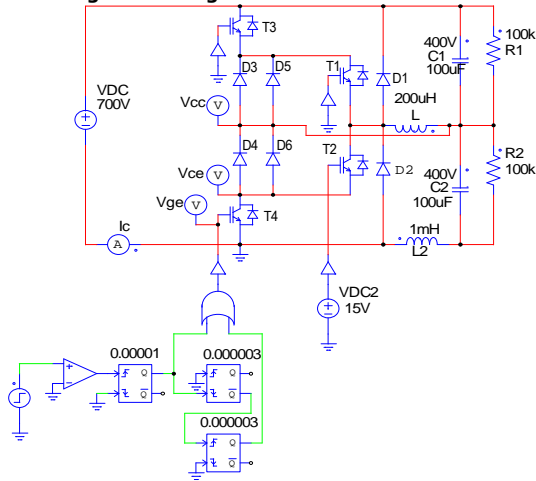
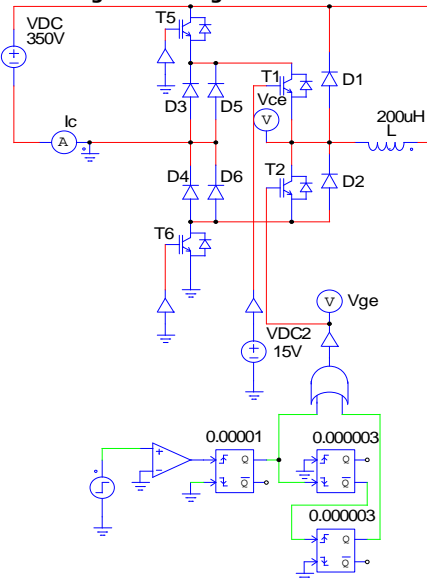

figure 11. BOOST stage switching measurement circuit





Ordering Code & Marking						
Version				Ordering Code		
without thermal paste with solder pins 17mm housing				10-F007NRA050SG-P966F09		
NN-NNNNNNNNNNNNNNNN TTTTUVVWWYY UL VIN LLLLL SSSS						
Text	Name		Date code	UL & VIN	Lot	Serial
	NN-NNNNNNNNNNNNNN-TTTTUVV		WWYY	UL VIN	LLLLL	SSSS
Datamatrix	Type&Ver	Lot number	Serial	Date code		
	TTTTTUVV	LLLLL	SSSS	WWYY		

Pin table			
Pin	X	Y	Function
1	33,6	0	G6
2	30,7	0	S6
3	27,8	0	NC
4	22	0	DC-
5	19,2	0	DC-
6	11,4	0	GND
7	0	0	S2
8	0	2,9	G2
9	0	9,9	Line
10	0	12,7	Line
11	0	15,5	Line
12	0	19,7	G1
13	0	22,6	S1
14	10,1	22,6	GND
15	17,9	22,6	DC+
16	20,8	22,6	DC+
17	27,8	22,6	NC
18	30,7	22,6	S5
19	33,6	22,6	G5
20	33,6	14,8	NTC1
21	33,6	8,2	NTC2

Tolerance of pinpositions $\pm 0,5\text{mm}$ at the end of pins
Dimension of coordinate axis is only offset without tolerance

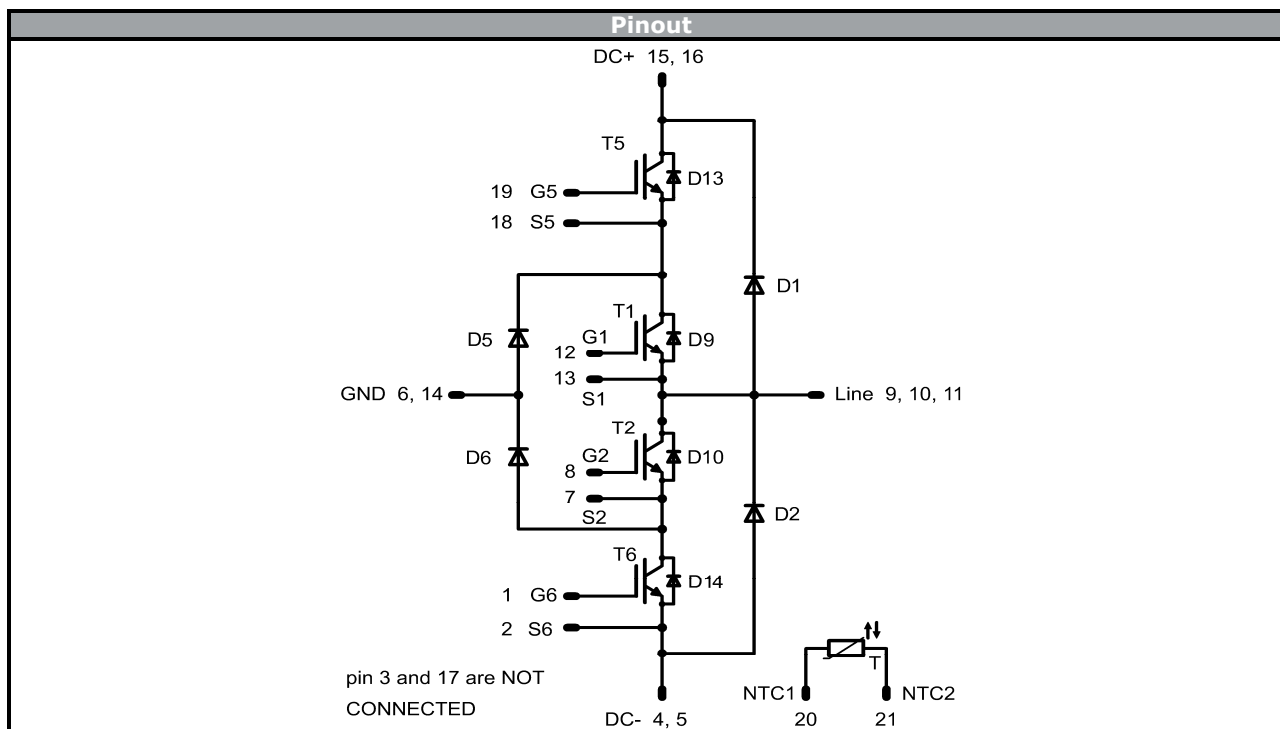

Identification					
ID	Component	Voltage	Current	Function	Comment
T5, T6	IGBT	650 V	50 A	Buck Switch	
D5, D6	FWD	600 V	16 A	Buck Diode	
D13, D14	FWD	650 V	10 A	Buck Sw. Protection Diode	
T1, T2	IGBT	1200 V	35 A	Boost IGBT	
D1, D2	FWD	1200 V	25 A	Boost Diode	
D9, D10	FWD	1200 V	7 A	Boost Sw. Protection Diode	
T	Thermistor			Thermistor	



Packaging instruction			
Standard packaging quantity (SPQ)	135	>SPQ Standard	<SPQ Sample

Handling instruction
Handling instructions for <i>flow</i> 0 packages see vincotech.com website.

Package data
Package data for <i>flow</i> 0 packages see vincotech.com website.

UL recognition and file number
This device is certified according to UL 1557 standard, UL file number E192116. For more information see vincotech.com website. 

Document No.:	Date:	Modification:	Pages
10-F007NRA050SG-P966F09-D2-14	20 Jun. 2016	New brand, PCM Rth values	all

DISCLAIMER

The information, specifications, procedures, methods and recommendations herein (together "information") are presented by Vincotech to reader in good faith, are believed to be accurate and reliable, but may well be incomplete and/or not applicable to all conditions or situations that may exist or occur. Vincotech reserves the right to make any changes without further notice to any products to improve reliability, function or design. No representation, guarantee or warranty is made to reader as to the accuracy, reliability or completeness of said information or that the application or use of any of the same will avoid hazards, accidents, losses, damages or injury of any kind to persons or property or that the same will not infringe third parties rights or give desired results. It is reader's sole responsibility to test and determine the suitability of the information and the product for reader's intended use.

LIFE SUPPORT POLICY

Vincotech products are not authorised for use as critical components in life support devices or systems without the express written approval of Vincotech.

As used herein:

1. Life support devices or systems are devices or systems which, (a) are intended for surgical implant into the body, or (b) support or sustain life, or (c) whose failure to perform when properly used in accordance with instructions for use provided in labelling can be reasonably expected to result in significant injury to the user.
2. A critical component is any component of a life support device or system whose failure to perform can be reasonably expected to cause the failure of the life support device or system, or to affect its safety or effectiveness.