

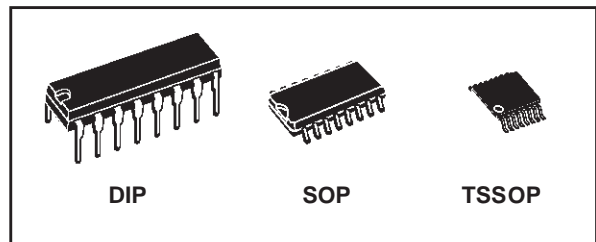

# M74HC237

## 3 TO 8 LINE DECODER LATCH

- HIGH SPEED:  
 $t_{PD} = 16\text{ns}$  (TYP.) at  $V_{CC} = 6\text{V}$
- LOW POWER DISSIPATION:  
 $I_{CC} = 4\mu\text{A}$ (MAX.) at  $T_A=25^\circ\text{C}$
- HIGH NOISE IMMUNITY:  
 $V_{NIH} = V_{NIL} = 28\% V_{CC}$  (MIN.)
- SYMMETRICAL OUTPUT IMPEDANCE:  
 $|I_{OH}| = I_{OL} = 4\text{mA}$  (MIN)
- BALANCED PROPAGATION DELAYS:  
 $t_{PLH} \approx t_{PHL}$
- WIDE OPERATING VOLTAGE RANGE:  
 $V_{CC}$  (OPR) = 2V to 6V
- PIN AND FUNCTION COMPATIBLE WITH  
 74 SERIES 237



### ORDER CODES

PACKAGE	TUBE	T & R
DIP	M74HC237B1R	
SOP	M74HC237M1R	M74HC237RM13TR
TSSOP		M74HC237TTR

### DESCRIPTION

The M74HC237 is an high speed CMOS 3 TO 8 LINE DECODER fabricated with silicon gate C<sup>2</sup>MOS technology.

When  $\overline{GL}$  goes from low to high, the address present at the select inputs (A, B, C) is stored in the latches. As long as  $\overline{GL}$  remains high no address changes will be recognized. Output enable controls, G1 and G2 control the state of the outputs independently of the select or

latch-enable inputs. All of the outputs are low unless G1 is high and G2 is low. The M74HC237 is ideally suited for the implementation of glitch-free decoders in stored-address applications in bus oriented systems. All inputs are equipped with protection circuits against static discharge and transient excess voltage.

### PIN CONNECTION AND IEC LOGIC SYMBOLS

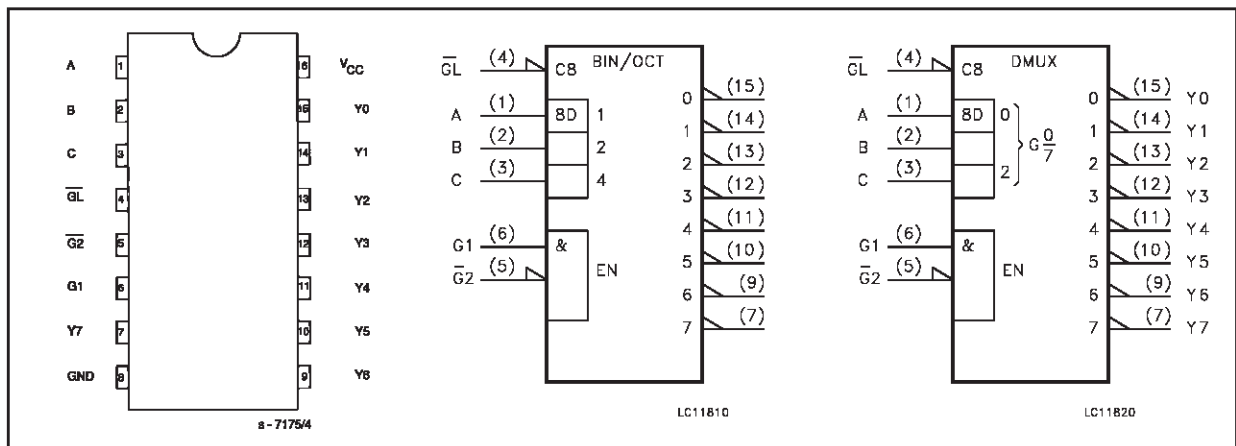

INPUT AND OUTPUT EQUIVALENT CIRCUIT

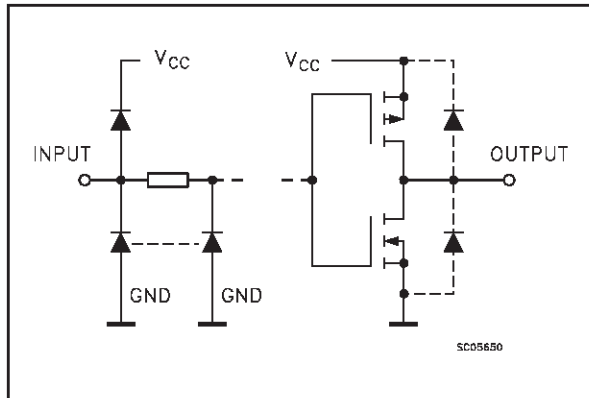

PIN DESCRIPTION

PIN No	SYMBOL	NAME AND FUNCTION
1, 2, 3	A, B, C	Data Inputs
4	GL	Latch Enable Input
5	G2	Data Enable Input (Active LOW)
6	G1	Data Enable Input (Active HIGH)
15, 14, 13, 12, 11, 10, 9, 7	Y0 to Y7	Decoder Outputs
8	GND	Ground (0V)
16	V <sub>CC</sub>	Positive Supply Voltage

TRUTH TABLE

INPUTS						OUTPUTS							
ENABLE			SELECT										
GL	G2	G1	C	B	A	Y0	Y1	Y2	Y3	Y4	Y5	Y6	Y7
X	X	L	X	X	X	L	L	L	L	L	L	L	L
X	H	X	X	X	X	L	L	L	L	L	L	L	L
L	L	H	L	L	L	H	L	L	L	L	L	L	L
L	L	H	L	L	H	L	H	L	L	L	L	L	L
L	L	H	L	H	L	L	L	H	L	L	L	L	L
L	L	H	L	H	H	L	L	L	H	L	L	L	L
L	L	H	H	L	L	L	L	L	L	H	L	L	L
L	L	H	H	L	H	L	L	L	L	L	H	L	L
L	L	H	H	H	L	L	L	L	L	L	L	H	L
L	L	H	H	H	H	L	L	L	L	L	L	L	H
H	L	H	X	X	X	Outputs corresponding to stored address H: all others L							

X : Don't Care

## LOGIC DIAGRAM

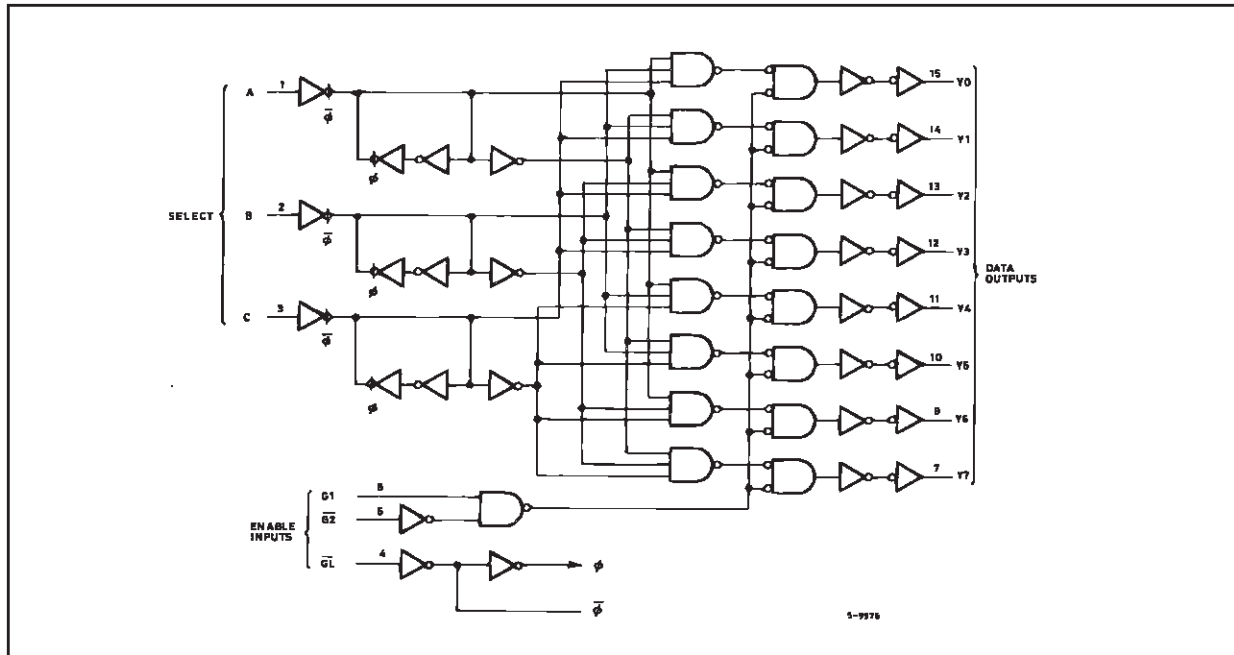

This logic diagram has not been used to estimate propagation delays

## ABSOLUTE MAXIMUM RATINGS

Symbol	Parameter	Value	Unit
$V_{CC}$	Supply Voltage	-0.5 to +7	V
$V_I$	DC Input Voltage	-0.5 to $V_{CC} + 0.5$	V
$V_O$	DC Output Voltage	-0.5 to $V_{CC} + 0.5$	V
$I_{IK}$	DC Input Diode Current	$\pm 20$	mA
$I_{OK}$	DC Output Diode Current	$\pm 20$	mA
$I_O$	DC Output Current	$\pm 25$	mA
$I_{CC}$ or $I_{GND}$	DC $V_{CC}$ or Ground Current	$\pm 50$	mA
$P_D$	Power Dissipation	500(*)	mW
$T_{stg}$	Storage Temperature	-65 to +150	$^{\circ}C$
$T_L$	Lead Temperature (10 sec)	300	$^{\circ}C$

Absolute Maximum Ratings are those values beyond which damage to the device may occur. Functional operation under these conditions is not implied

(\*) 500mW at 65  $^{\circ}C$ ; derate to 300mW by 10mW/ $^{\circ}C$  from 65 $^{\circ}C$  to 85 $^{\circ}C$

## RECOMMENDED OPERATING CONDITIONS

Symbol	Parameter	Value	Unit	
$V_{CC}$	Supply Voltage	2 to 6	V	
$V_I$	Input Voltage	0 to $V_{CC}$	V	
$V_O$	Output Voltage	0 to $V_{CC}$	V	
$T_{op}$	Operating Temperature	-55 to 125	$^{\circ}C$	
$t_r, t_f$	Input Rise and Fall Time	$V_{CC} = 2.0V$	0 to 1000	ns
		$V_{CC} = 4.5V$	0 to 500	ns
		$V_{CC} = 6.0V$	0 to 400	ns

## DC SPECIFICATIONS

Symbol	Parameter	Test Condition		Value						Unit	
		V <sub>CC</sub> (V)		T <sub>A</sub> = 25°C			-40 to 85°C		-55 to 125°C		
				Min.	Typ.	Max.	Min.	Max.	Min.		Max.
V <sub>IH</sub>	High Level Input Voltage	2.0		1.5			1.5		1.5		V
		4.5		3.15			3.15		3.15		
		6.0		4.2			4.2		4.2		
V <sub>IL</sub>	Low Level Input Voltage	2.0				0.5		0.5		0.5	V
		4.5				1.35		1.35		1.35	
		6.0				1.8		1.8		1.8	
V <sub>OH</sub>	High Level Output Voltage	2.0	I <sub>O</sub> =-20 μA	1.9	2.0		1.9		1.9		V
		4.5	I <sub>O</sub> =-20 μA	4.4	4.5		4.4		4.4		
		6.0	I <sub>O</sub> =-20 μA	5.9	6.0		5.9		5.9		
		4.5	I <sub>O</sub> =-4.0 mA	4.18	4.31		4.13		4.10		
		6.0	I <sub>O</sub> =-5.2 mA	5.68	5.8		5.63		5.60		
V <sub>OL</sub>	Low Level Output Voltage	2.0	I <sub>O</sub> =20 μA		0.0	0.1		0.1		0.1	V
		4.5	I <sub>O</sub> =20 μA		0.0	0.1		0.1		0.1	
		6.0	I <sub>O</sub> =20 μA		0.0	0.1		0.1		0.1	
		4.5	I <sub>O</sub> =4.0 mA		0.17	0.26		0.33		0.40	
		6.0	I <sub>O</sub> =5.2 mA		0.18	0.26		0.33		0.40	
I <sub>I</sub>	Input Leakage Current	6.0	V <sub>I</sub> = V <sub>CC</sub> or GND			± 0.1		± 1		± 1	μA
I <sub>CC</sub>	Quiescent Supply Current	6.0	V <sub>I</sub> = V <sub>CC</sub> or GND			4		40		80	μA

AC ELECTRICAL CHARACTERISTICS ( $C_L = 50 \text{ pF}$ , Input  $t_r = t_f = 6 \text{ ns}$ )

Symbol	Parameter	Test Condition		Value						Unit	
		$V_{CC}$ (V)		$T_A = 25^\circ\text{C}$			$-40 \text{ to } 85^\circ\text{C}$		$-55 \text{ to } 125^\circ\text{C}$		
				Min.	Typ.	Max.	Min.	Max.	Min.		Max.
$t_{TLH}$ $t_{THL}$	Output Transition Time	2.0			30	75		95		110	ns
		4.5			8	15		19		22	
		6.0			7	13		16		19	
$t_{PLH}$ $t_{PHL}$	Propagation Delay Time (A, B, C - Y)	2.0			60	180		225		270	ns
		4.5			19	36		45		54	
		6.0			16	31		38		46	
$t_{PLH}$ $t_{PHL}$	Propagation Delay Time (G1 - Y)	2.0			45	140		175		210	ns
		4.5			15	28		35		42	
		6.0			13	24		30		36	
$t_{PLH}$ $t_{PHL}$	Propagation Delay Time (G2 - Y)	2.0			45	140		175		210	ns
		4.5			15	28		35		42	
		6.0			13	24		30		36	
$t_{PLH}$ $t_{PHL}$	Propagation Delay Time (GL - Y)	2.0			65	190		240		285	ns
		4.5			21	38		48		57	
		6.0			18	32		41		48	
$t_{W(L)}$	Minimum Pulse Width (GL)	2.0			10	75		95		110	ns
		4.5			6	15		19		22	
		6.0			6	13		16		19	
$t_s$	Minimum Set-up Time (A, B, C - GL)	2.0			12	50		65		75	ns
		4.5			3	10		13		15	
		6.0			2	9		11		13	
$t_h$	Minimum Hold Time (A, B, C - GL)	2.0				25		30		40	ns
		4.5				5		6		8	
		6.0				5		5		7	

## CAPACITIVE CHARACTERISTICS

Symbol	Parameter	Test Condition		Value						Unit	
		$V_{CC}$ (V)		$T_A = 25^\circ\text{C}$			$-40 \text{ to } 85^\circ\text{C}$		$-55 \text{ to } 125^\circ\text{C}$		
				Min.	Typ.	Max.	Min.	Max.	Min.		Max.
$C_{IN}$	Input Capacitance	5.0			5	10		10		10	pF
$C_{PD}$	Power Dissipation Capacitance (note 1)	5.0			52						pF

1)  $C_{PD}$  is defined as the value of the IC's internal equivalent capacitance which is calculated from the operating current consumption without load.

TEST CIRCUIT

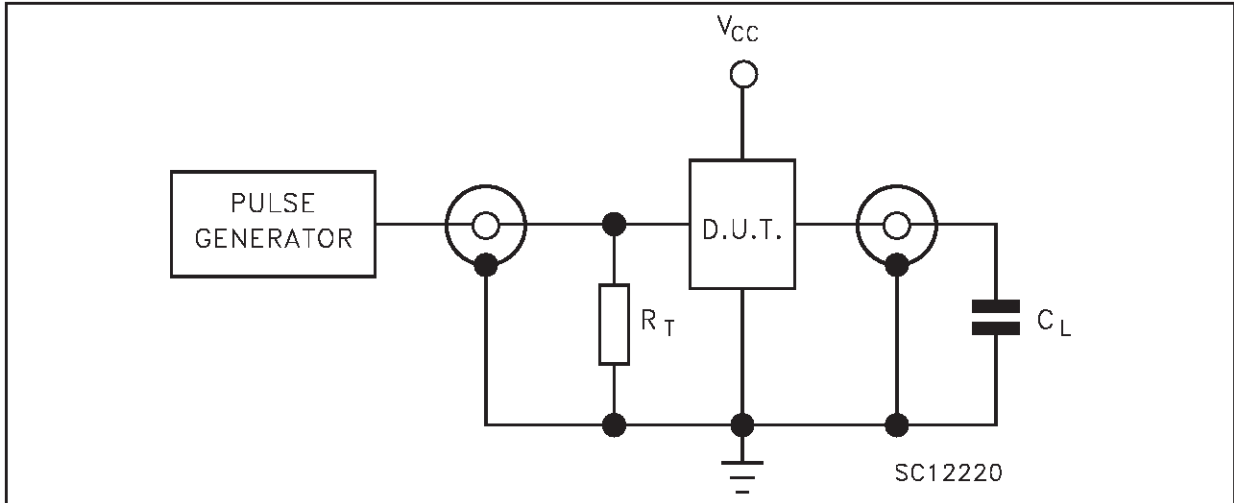

$C_L = 50\text{pF}$  or equivalent (includes jig and probe capacitance)  
 $R_T = Z_{OUT}$  of pulse generator (typically  $50\Omega$ )

WAVEFORM 1: PROPAGATION DELAY TIME ( $f=1\text{MHz}$ ; 50% duty cycle)

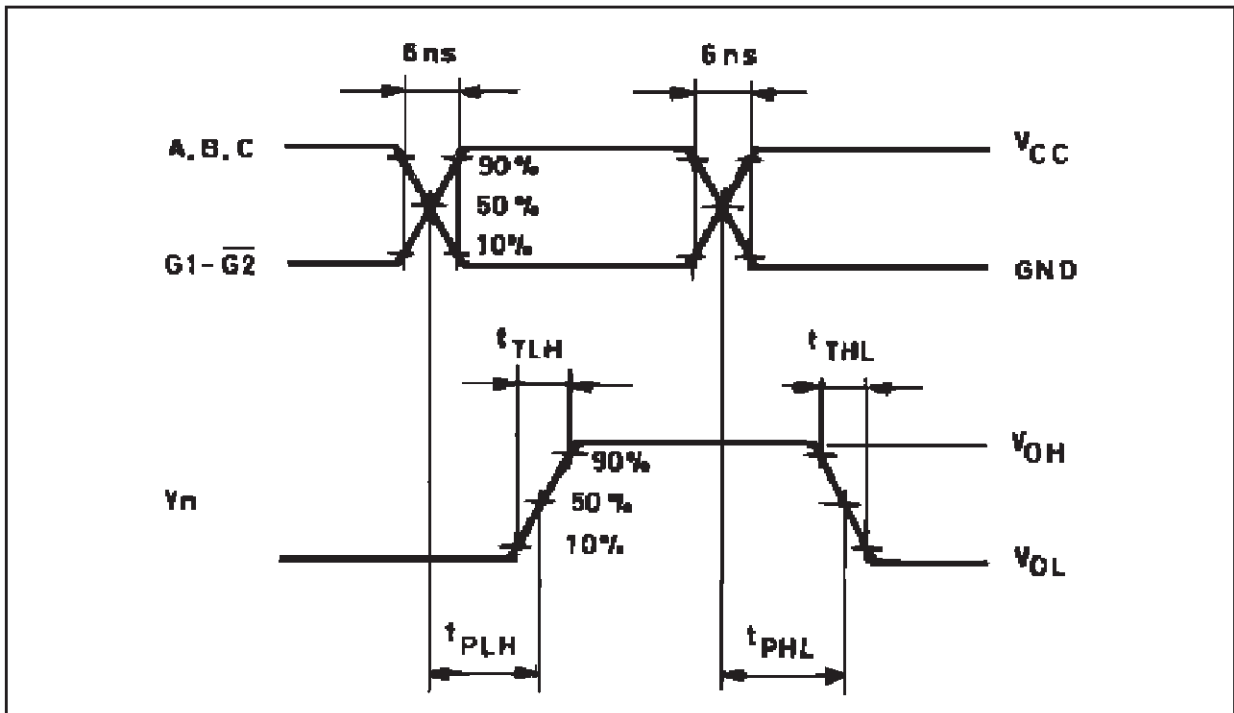

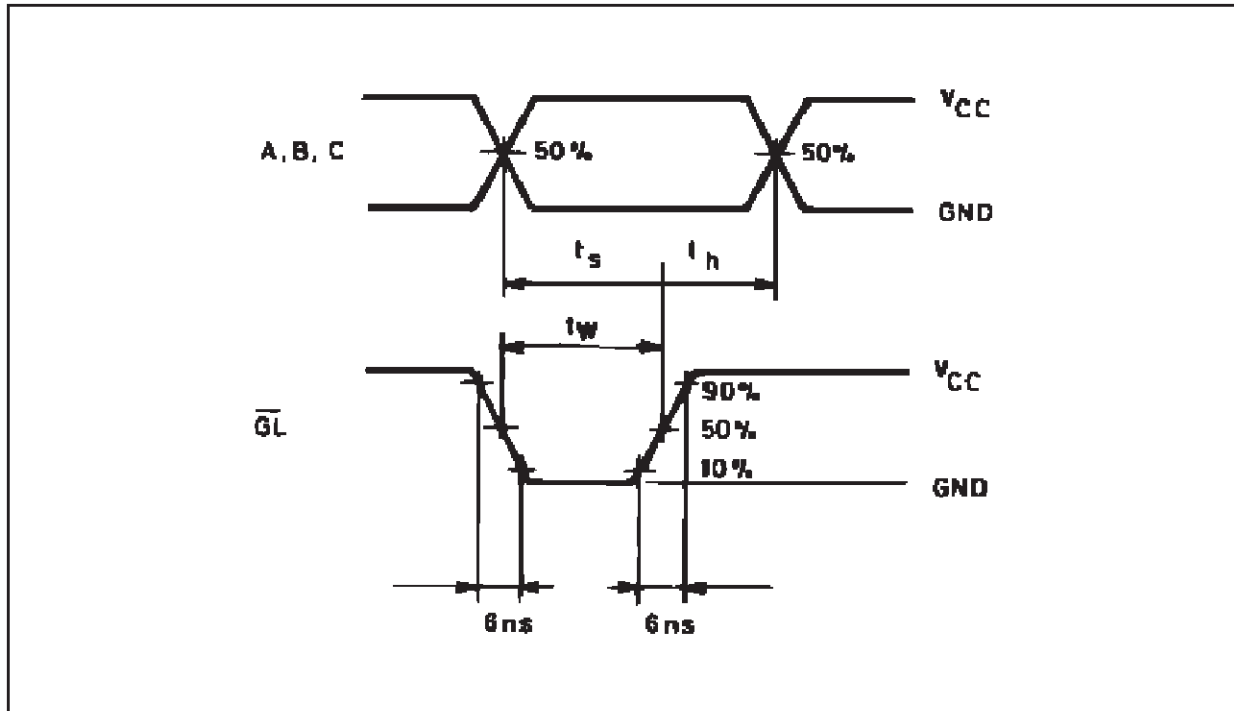
WAVEFORM 2: SETUP AND HOLD TIME, MINIMUM PULSE WIDTH ( $\overline{GL}$ ) ( $f=1\text{MHz}$ ; 50% duty cycle)

**Plastic DIP-16 (0.25) MECHANICAL DATA**

DIM.	mm.			inch		
	MIN.	TYP	MAX.	MIN.	TYP.	MAX.
a1	0.51			0.020		
B	0.77		1.65	0.030		0.065
b		0.5			0.020	
b1		0.25			0.010	
D			20			0.787
E		8.5			0.335	
e		2.54			0.100	
e3		17.78			0.700	
F			7.1			0.280
I			5.1			0.201
L		3.3			0.130	
Z			1.27			0.050

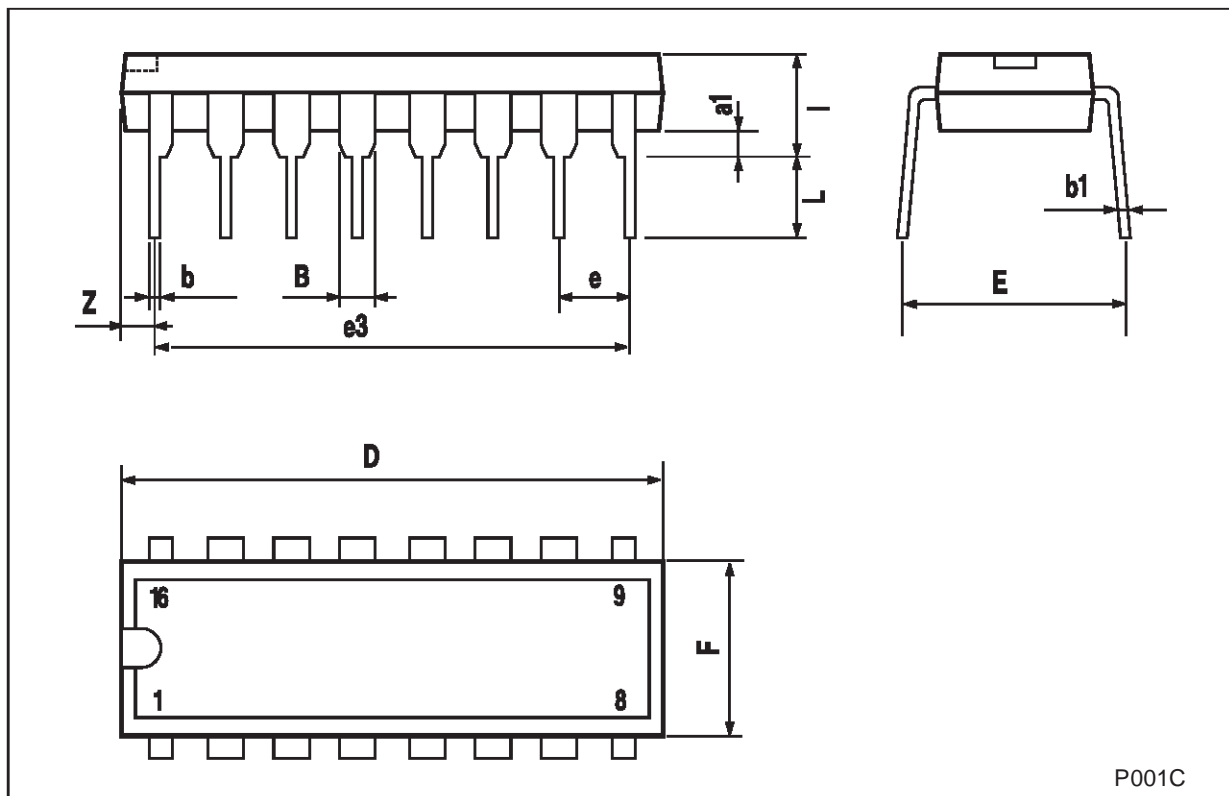

P001C



## SO-16 MECHANICAL DATA

DIM.	mm.			inch		
	MIN.	TYP.	MAX.	MIN.	TYP.	MAX.
A			1.75			0.068
a1	0.1		0.2	0.003		0.007
a2			1.65			0.064
b	0.35		0.46	0.013		0.018
b1	0.19		0.25	0.007		0.010
C		0.5			0.019	
c1	45° (typ.)					
D	9.8		10	0.385		0.393
E	5.8		6.2	0.228		0.244
e		1.27			0.050	
e3		8.89			0.350	
F	3.8		4.0	0.149		0.157
G	4.6		5.3	0.181		0.208
L	0.5		1.27	0.019		0.050
M			0.62			0.024
S	8° (max.)					

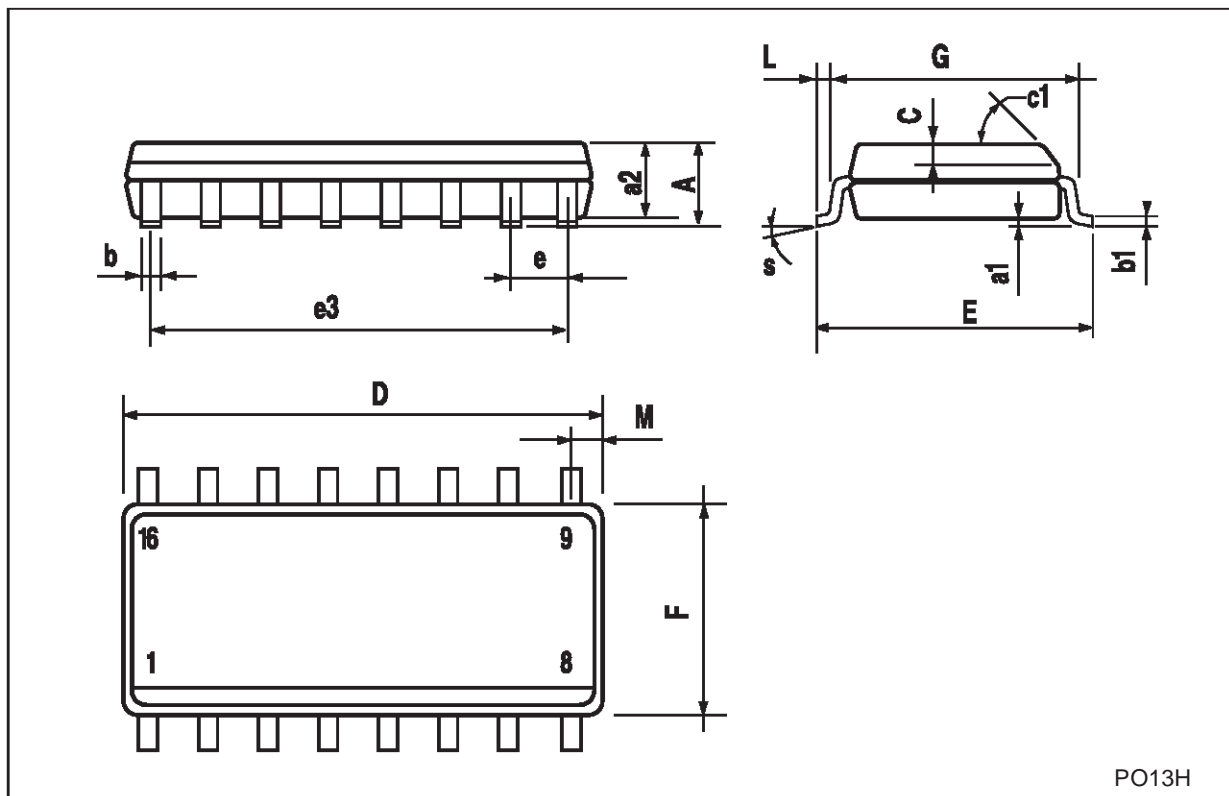

PO13H

## TSSOP16 MECHANICAL DATA

DIM.	mm.			inch		
	MIN.	TYP	MAX.	MIN.	TYP.	MAX.
A			1.2			0.047
A1	0.05		0.15	0.002	0.004	0.006
A2	0.8	1	1.05	0.031	0.039	0.041
b	0.19		0.30	0.007		0.012
c	0.09		0.20	0.004		0.0089
D	4.9	5	5.1	0.193	0.197	0.201
E	6.2	6.4	6.6	0.244	0.252	0.260
E1	4.3	4.4	4.48	0.169	0.173	0.176
e		0.65 BSC			0.0256 BSC	
K	0°		8°	0°		8°
L	0.45	0.60	0.75	0.018	0.024	0.030

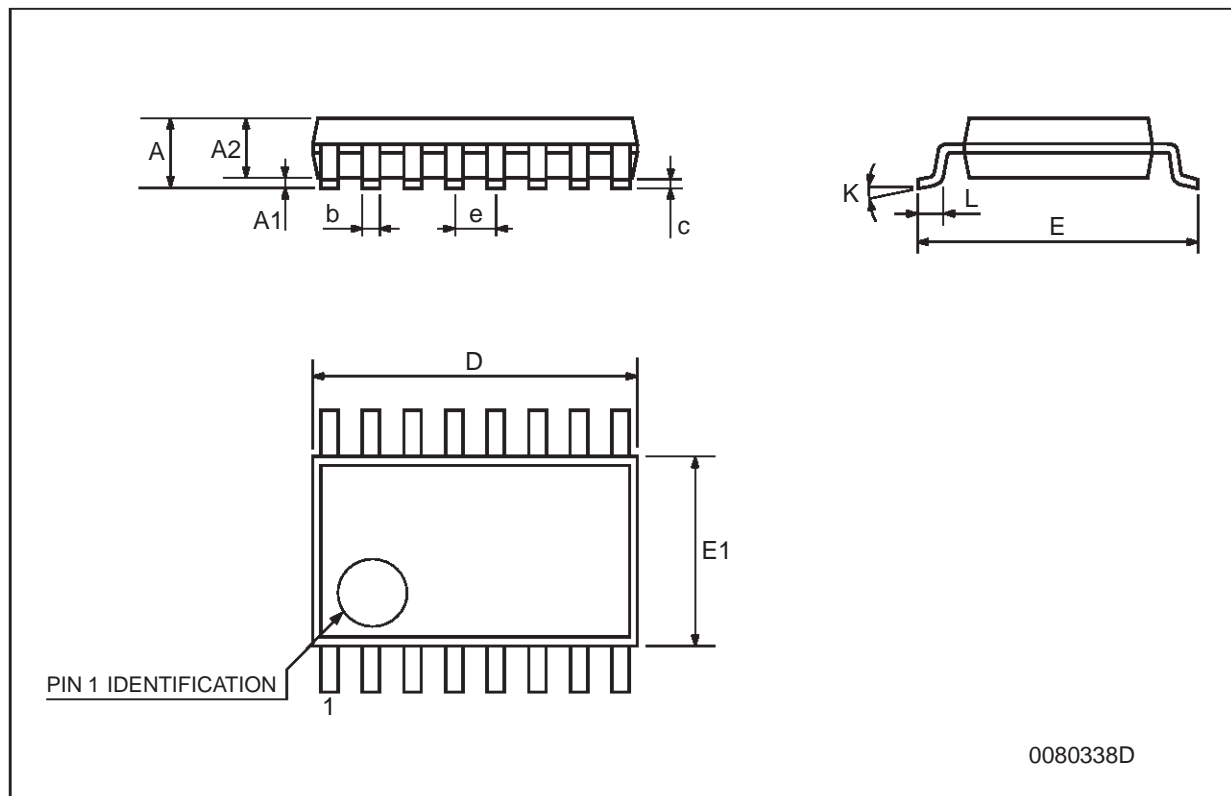

0080338D

Information furnished is believed to be accurate and reliable. However, STMicroelectronics assumes no responsibility for the consequences of use of such information nor for any infringement of patents or other rights of third parties which may result from its use. No license is granted by implication or otherwise under any patent or patent rights of STMicroelectronics. Specifications mentioned in this publication are subject to change without notice. This publication supersedes and replaces all information previously supplied. STMicroelectronics products are not authorized for use as critical components in life support devices or systems without express written approval of STMicroelectronics.

© The ST logo is a registered trademark of STMicroelectronics

© 2001 STMicroelectronics - Printed in Italy - All Rights Reserved  
STMicroelectronics GROUP OF COMPANIES

Australia - Brazil - China - Finland - France - Germany - Hong Kong - India - Italy - Japan - Malaysia - Malta - Morocco  
Singapore - Spain - Sweden - Switzerland - United Kingdom

© <http://www.st.com>

