

HEXFET® Power MOSFET

<b>V<sub>DSS</sub></b>	<b>100</b>	<b>V</b>
<b>R<sub>DS(on)</sub> max</b> (@V <sub>GS</sub> = 10V)	<b>115</b>	<b>mΩ</b>
<b>Q<sub>g</sub> (typical)</b>	<b>17</b>	<b>nC</b>
<b>I<sub>D</sub></b> (@T <sub>C (Bottom)</sub> = 25°C)	<b>11</b> Ⓢ	<b>A</b>

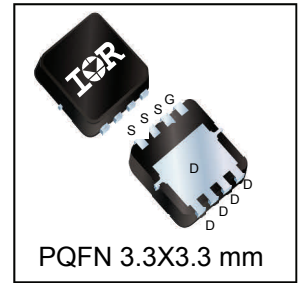
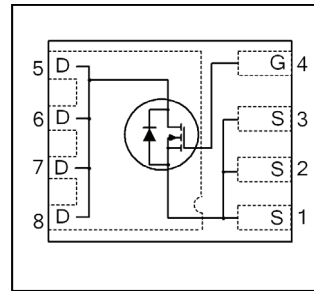

**Applications**

- POE+ Power Sourcing Equipment Switch

**Features**

Large Safe Operating Area (SOA)
Low Thermal Resistance to PCB
Low Profile (<1.05mm)
Industry-Standard Pinout
Compatible with Existing Surface Mount Techniques
RoHS Compliant, Halogen-Free
MSL1, Industrial Qualification

results in

⇒

**Benefits**

Increased Ruggedness
Enable better thermal dissipation
Increased Power Density
Multi-Vendor Compatibility
Easier Manufacturing
Environmentally Friendlier
Increased Reliability

Base part number	Package Type	Standard Pack		Orderable Part Number
		Form	Quantity	
IRFHM3911PbF	PQFN 3.3mm x 3.3mm	Tape and Reel	4000	IRFHM3911TRPbF

**Absolute Maximum Ratings**

	Parameter	Max.	Units
V <sub>GS</sub>	Gate-to-Source Voltage	± 20	V
I <sub>D</sub> @ T <sub>A</sub> = 25°C	Continuous Drain Current, V <sub>GS</sub> @ 10V	3.2	A
I <sub>D</sub> @ T <sub>C(Bottom)</sub> = 25°C	Continuous Drain Current, V <sub>GS</sub> @ 10V	11Ⓢ	
I <sub>D</sub> @ T <sub>C(Bottom)</sub> = 100°C	Continuous Drain Current, V <sub>GS</sub> @ 10V	6.6	
I <sub>D</sub> @ T <sub>C</sub> = 25°C	Continuous Drain Current, V <sub>GS</sub> @ 10V (Source Bonding Technology Limited)	20Ⓣ	
I <sub>DM</sub>	Pulsed Drain Current ①	36	
P <sub>D</sub> @ T <sub>A</sub> = 25°C	Power Dissipation ⑤	2.8	W
P <sub>D</sub> @ T <sub>C(Bottom)</sub> = 25°C	Power Dissipation	29	
	Linear Derating Factor	0.023	W/°C
T <sub>J</sub> T <sub>STG</sub>	Operating Junction and Storage Temperature Range	-55 to + 150	°C

Notes ① through ⑦ are on page 9

**Static @ T<sub>J</sub> = 25°C (unless otherwise specified)**

	Parameter	Min.	Typ.	Max.	Units	Conditions
BV <sub>DSS</sub>	Drain-to-Source Breakdown Voltage	100	—	—	V	V <sub>GS</sub> = 0V, I <sub>D</sub> = 250μA
ΔBV <sub>DSS</sub> /ΔT <sub>J</sub>	Breakdown Voltage Temp. Coefficient	—	111	—	mV/°C	Reference to 25°C, I <sub>D</sub> = 1mA
R <sub>DS(on)</sub>	Static Drain-to-Source On-Resistance	—	92	115	mΩ	V <sub>GS</sub> = 10V, I <sub>D</sub> = 6.3A ③
V <sub>GS(th)</sub>	Gate Threshold Voltage	2.0	—	4.0	V	V <sub>DS</sub> = V <sub>GS</sub> , I <sub>D</sub> = 35μA
ΔV <sub>GS(th)</sub>	Gate Threshold Voltage Coefficient	—	-7.6	—	mV/°C	
I <sub>DSS</sub>	Drain-to-Source Leakage Current	—	—	20	μA	V <sub>DS</sub> = 100V, V <sub>GS</sub> = 0V
		—	—	250		V <sub>DS</sub> = 80V, V <sub>GS</sub> = 0V, T <sub>J</sub> = 125°C
I <sub>GSS</sub>	Gate-to-Source Forward Leakage	—	—	100	nA	V <sub>GS</sub> = 20V
	Gate-to-Source Reverse Leakage	—	—	-100		V <sub>GS</sub> = -20V
g <sub>fs</sub>	Forward Transconductance	20	—	—	S	V <sub>DS</sub> = 25V, I <sub>D</sub> = 6.3A
Q <sub>g</sub>	Total Gate Charge	—	17	26		
Q <sub>gs1</sub>	Pre-V <sub>th</sub> Gate-to-Source Charge	—	2.5	—		V <sub>DS</sub> = 50V
Q <sub>gs2</sub>	Post-V <sub>th</sub> Gate-to-Source Charge	—	1.4	—		V <sub>GS</sub> = 10V
Q <sub>gd</sub>	Gate-to-Drain Charge	—	5.4	—		I <sub>D</sub> = 6.3A
Q <sub>godr</sub>	Gate Charge Overdrive	—	7.7	—		
Q <sub>sw</sub>	Switch Charge (Q <sub>gs2</sub> + Q <sub>gd</sub> )	—	6.8	—		
Q <sub>oss</sub>	Output Charge	—	5.9	—	nC	V <sub>DS</sub> = 16V, V <sub>GS</sub> = 0V
R <sub>G</sub>	Gate Resistance	—	3.8	—	Ω	
t <sub>d(on)</sub>	Turn-On Delay Time	—	5.0	—		V <sub>DD</sub> = 50V, V <sub>GS</sub> = 10V
t <sub>r</sub>	Rise Time	—	5.8	—	ns	I <sub>D</sub> = 6.3A
t <sub>d(off)</sub>	Turn-Off Delay Time	—	16	—		R <sub>G</sub> = 1.8Ω
t <sub>f</sub>	Fall Time	—	5.1	—		
C <sub>iss</sub>	Input Capacitance	—	760	—		V <sub>GS</sub> = 0V
C <sub>oss</sub>	Output Capacitance	—	73	—	pF	V <sub>DS</sub> = 50V
C <sub>rss</sub>	Reverse Transfer Capacitance	—	13	—		f = 1.0MHz

**Avalanche Characteristics**

	Parameter	Typ.	Max.
E <sub>AS</sub>	Single Pulse Avalanche Energy ②	—	41
I <sub>AR</sub>	Avalanche Current ①	—	6.3

**Diode Characteristics**

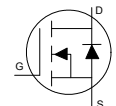
	Parameter	Min.	Typ.	Max.	Units	Conditions
I <sub>S</sub>	Continuous Source Current (Body Diode)	—	—	11	A	MOSFET symbol showing the integral reverse p-n junction diode. 
I <sub>SM</sub>	Pulsed Source Current (Body Diode) ①	—	—	36		
V <sub>SD</sub>	Diode Forward Voltage	—	—	1.3	V	T <sub>J</sub> = 25°C, I <sub>S</sub> = 6.3A, V <sub>GS</sub> = 0V ③
t <sub>rr</sub>	Reverse Recovery Time	—	47	71	ns	T <sub>J</sub> = 25°C, I <sub>F</sub> = 6.3A, V <sub>DD</sub> = 50V
Q <sub>rr</sub>	Reverse Recovery Charge	—	381	571	nC	di/dt = 500A/μs ③

**Thermal Resistance**

	Parameter	Typ.	Max.	Units
R <sub>θJC</sub> (Bottom)	Junction-to-Case ④	—	4.3	°C/W
R <sub>θJC</sub> (Top)	Junction-to-Case ④	—	40	
R <sub>θJA</sub>	Junction-to-Ambient ⑤	—	45	
R <sub>θJA</sub> (<10s)	Junction-to-Ambient ⑤	—	31	

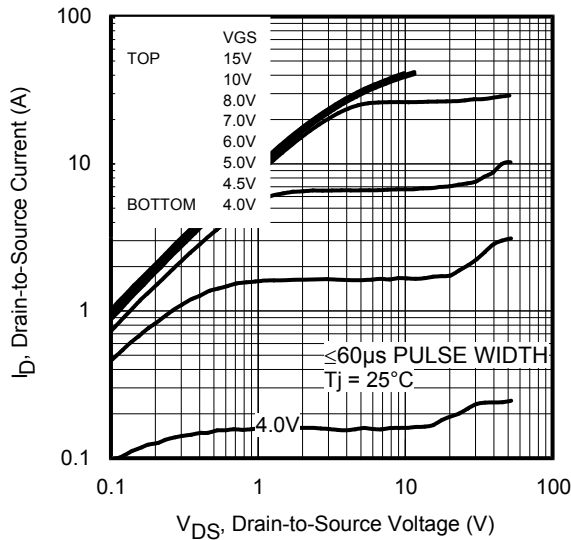
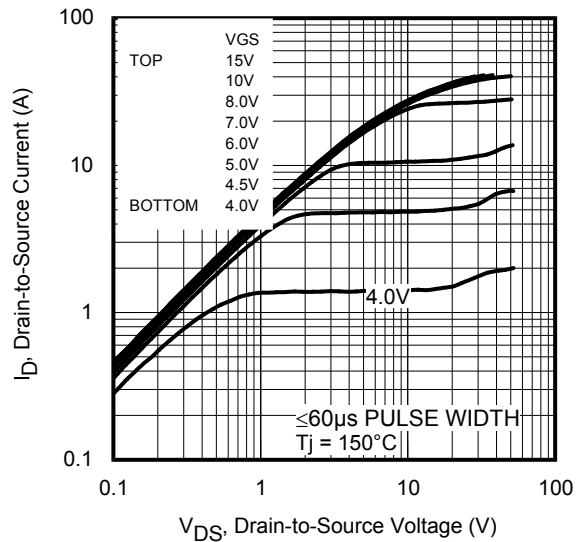
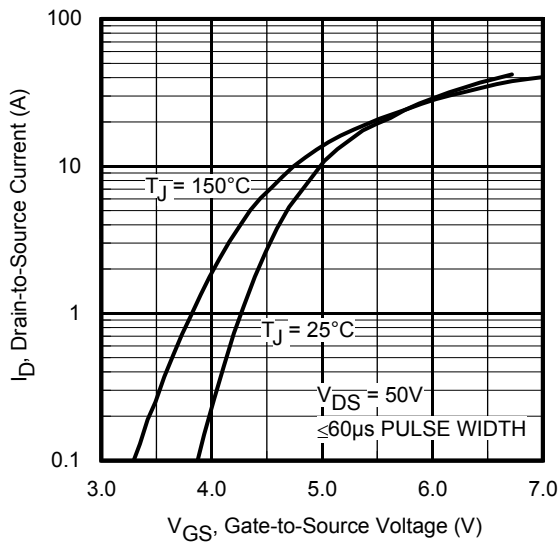
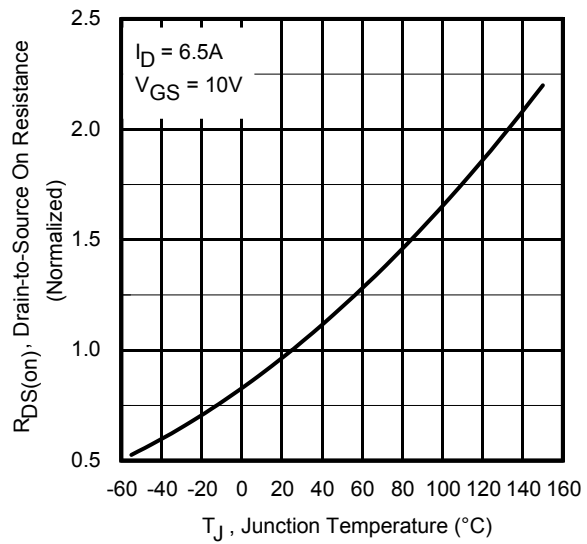
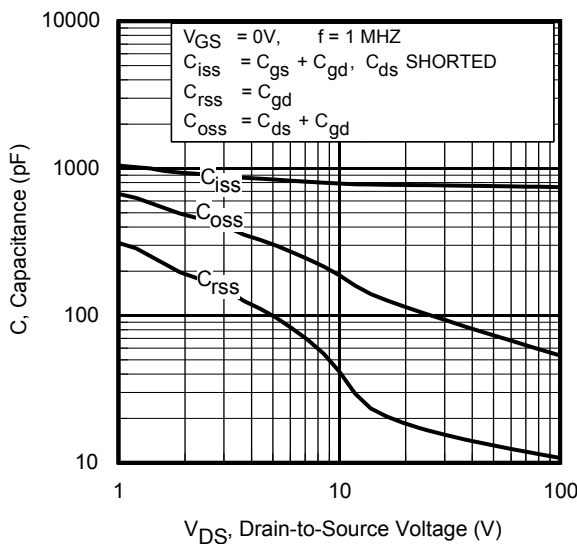
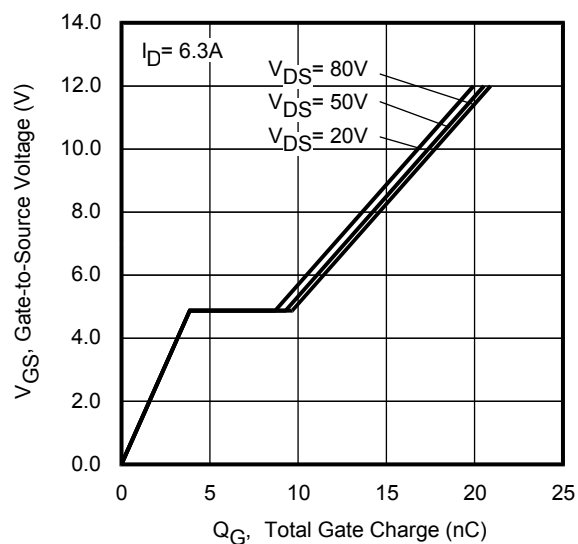
**Fig 1. Typical Output Characteristics**

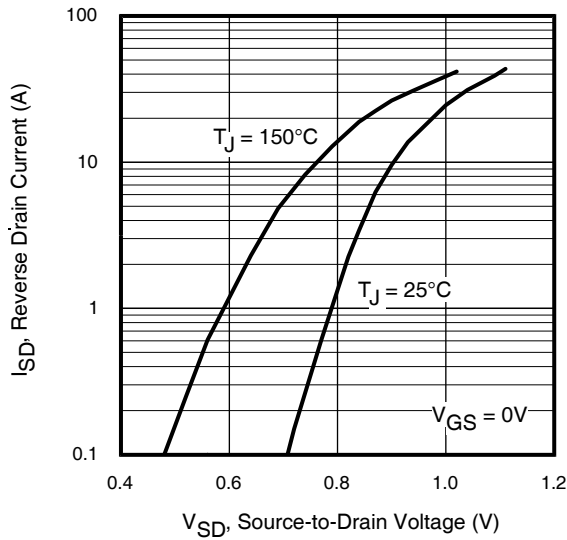
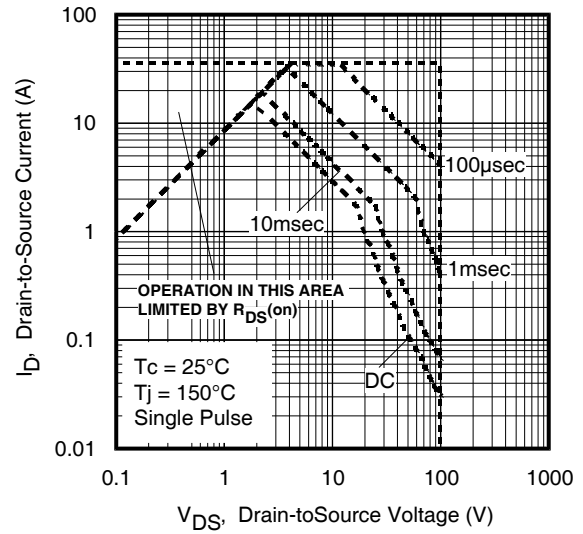
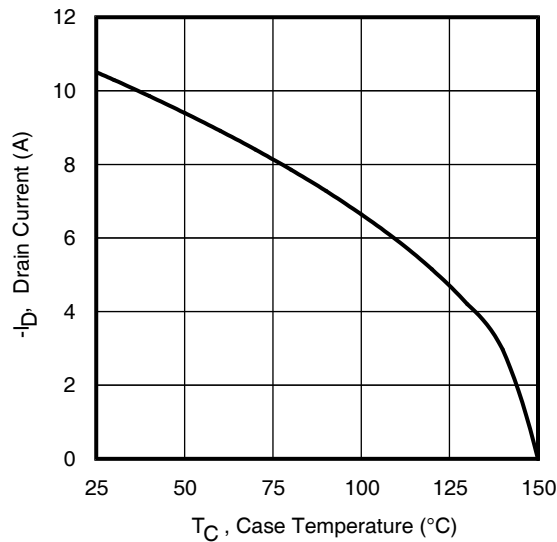
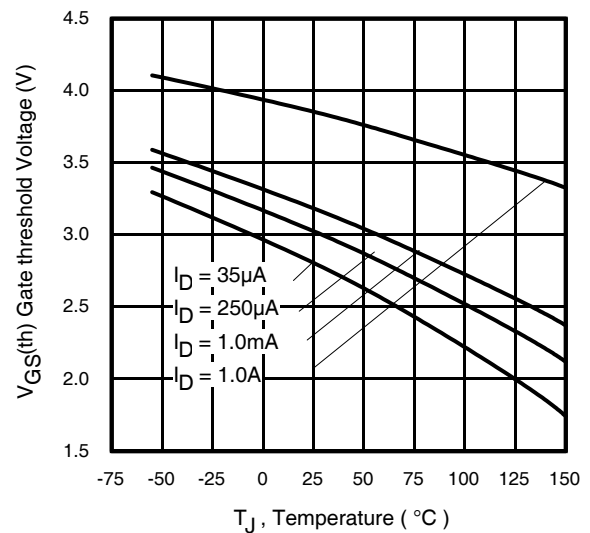
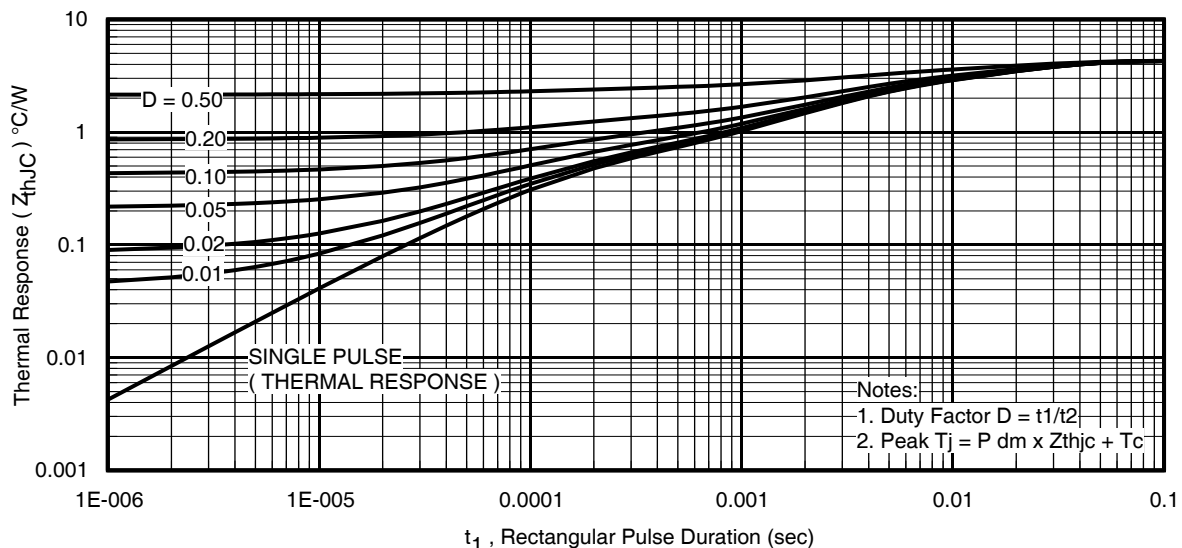
**Fig 2. Typical Output Characteristics**

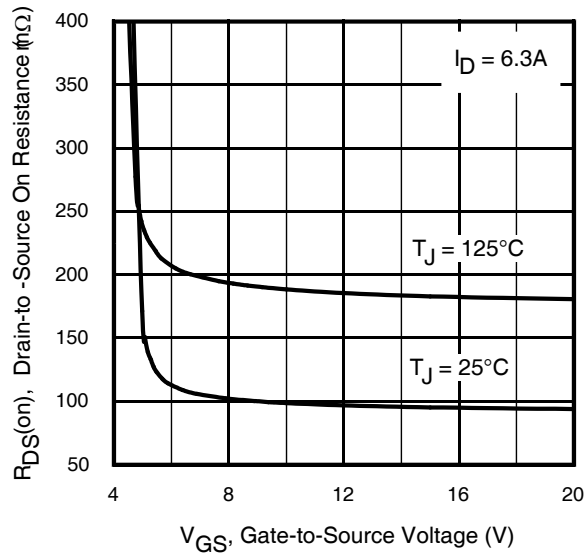
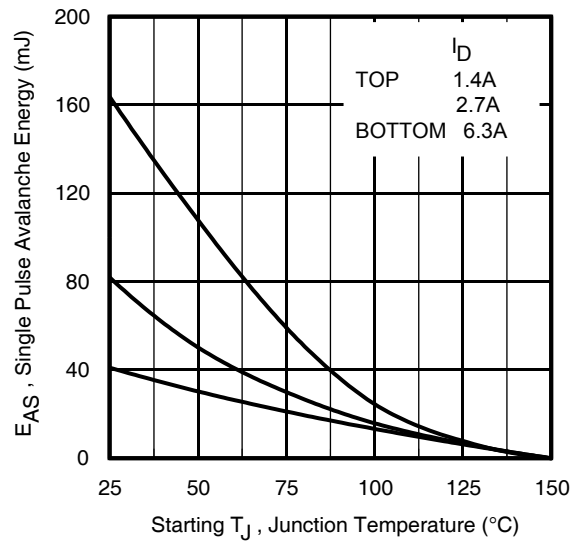
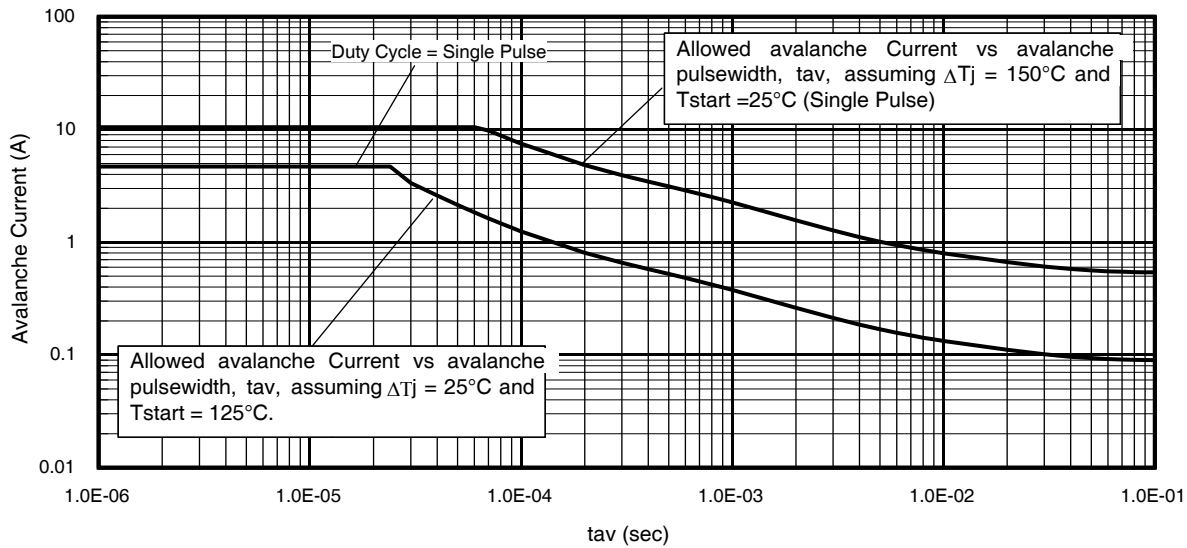
**Fig 3. Typical Transfer Characteristics**

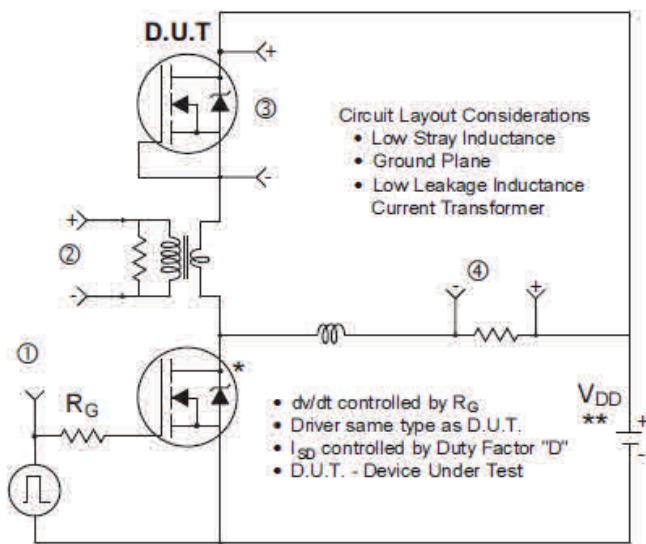
**Fig 4. Normalized On-Resistance vs. Temperature**

**Fig 5. Typical Capacitance vs. Drain-to-Source Voltage**

**Fig 6. Typical Gate Charge vs. Gate-to-Source Voltage**

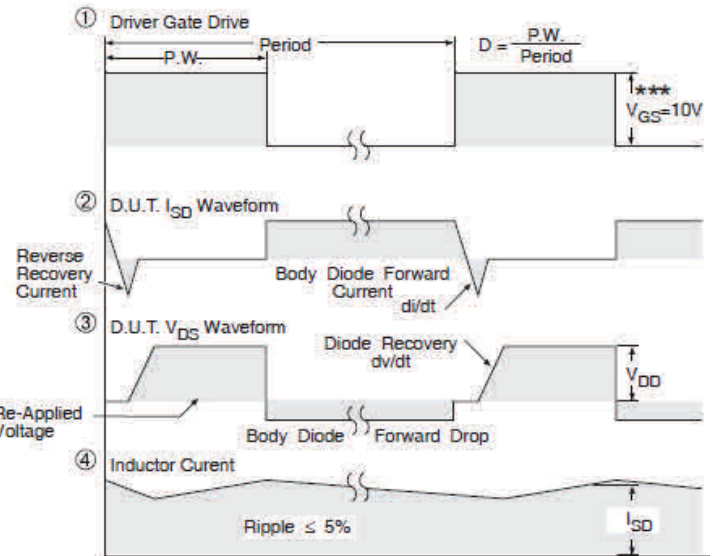

**Fig 7.** Typical Source-Drain Diode Forward Voltage

**Fig 8.** Maximum Safe Operating Area

**Fig 9.** Maximum Drain Current vs. Case Temperature

**Fig 10.** Drain-to-Source Breakdown Voltage

**Fig 11.** Maximum Effective Transient Thermal Impedance, Junction-to-Case

**Fig 12.** On- Resistance vs. Gate Voltage

**Fig 13.** Maximum Avalanche Energy vs. Drain Current

**Fig 14.** Typical Avalanche Current vs. Pulsewidth



\* Use P-Channel Driver for P-Channel Measurements  
 \*\* Reverse Polarity for P-Channel

**Fig 15. Peak Diode Recovery dv/dt Test Circuit for N-Channel HEXFET® Power MOSFETs**



\*\*\*  $V_{GS} = 5V$  for Logic Level Devices

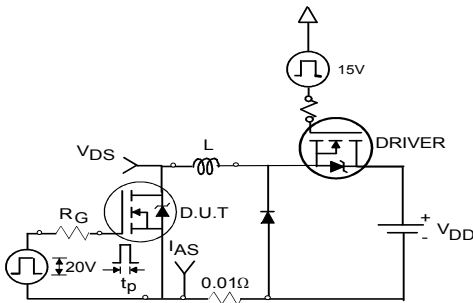

**Fig 16a. Unclamped Inductive Test Circuit**

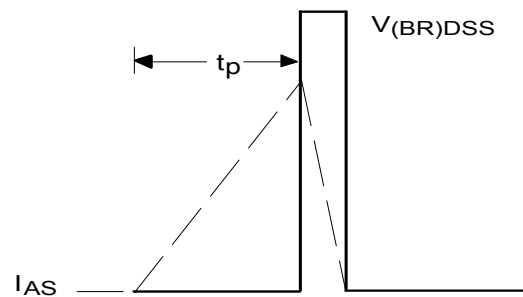

**Fig 16b. Unclamped Inductive Waveforms**

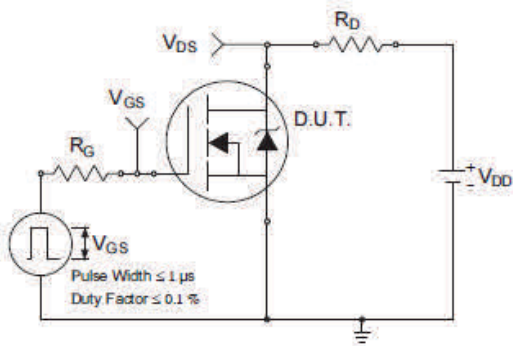

**Fig 17a. Switching Time Test Circuit**

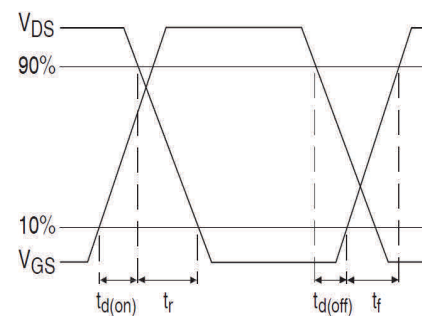

**Fig 17b. Switching Time Waveforms**

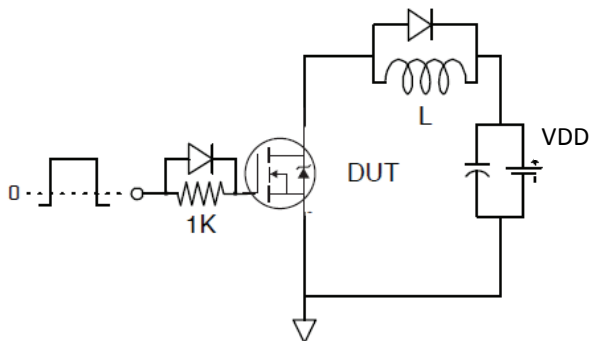

**Fig 18. Gate Charge Test Circuit**

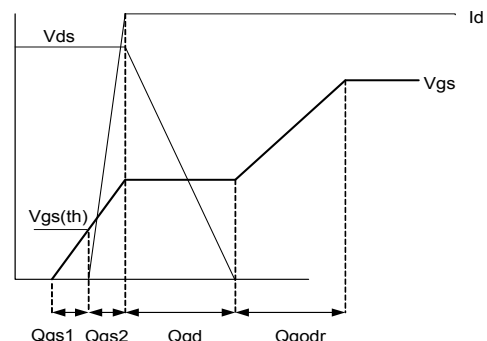

**Fig 19. Gate Charge Waveform**

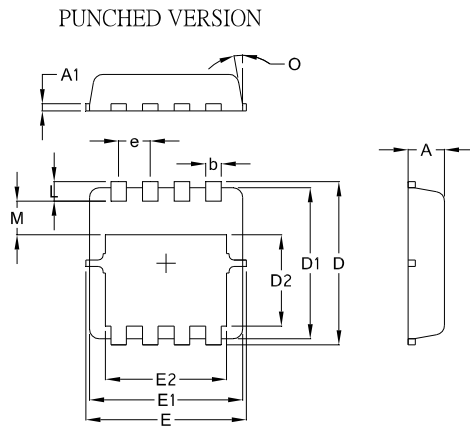
**PQFN 3.3 x 3.3 Package Details**

SYMBOL	COMMON			
	MM		INCH	
	MIN.	MAX.	MIN.	MAX.
A	0.70	1.05	0.0276	0.0413
A1	0.12	0.39	0.0047	0.0154
b	0.25	0.39	0.0098	0.0154
D	3.20	3.45	0.1260	0.1358
D1	3.00	3.20	0.1181	0.1417
D2	1.69	2.20	0.0665	0.0866
E	3.20	3.40	0.1260	0.1339
E1	3.00	3.20	0.1181	0.1417
E2	2.15	2.59	0.0846	0.1020
e	0.65 BSC		0.0256 BSC	
L	0.15	0.55	0.0059	0.0217
M	0.59	—	0.0232	—
O	9Deg	12Deg	9Deg	12Deg

For more information on board mounting, including footprint and stencil recommendation, please refer to application note AN-1136: <http://www.irf.com/technical-info/appnotes/an-1136.pdf>

For more information on package inspection techniques, please refer to application note AN-1154: <http://www.irf.com/technical-info/appnotes/an-1154.pdf>

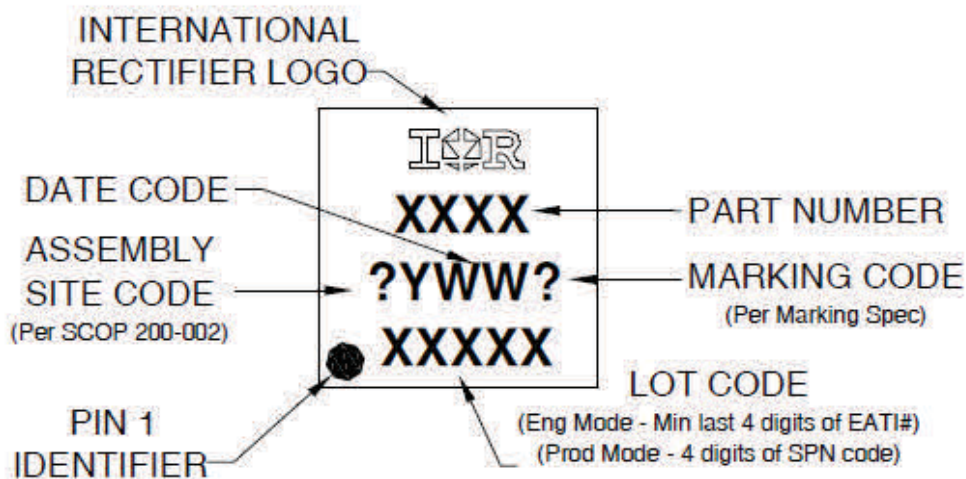
**PQFN 3.3 x 3.3 Part Marking**

Note: For the most current drawing please refer to IR website at <http://www.irf.com/package/>

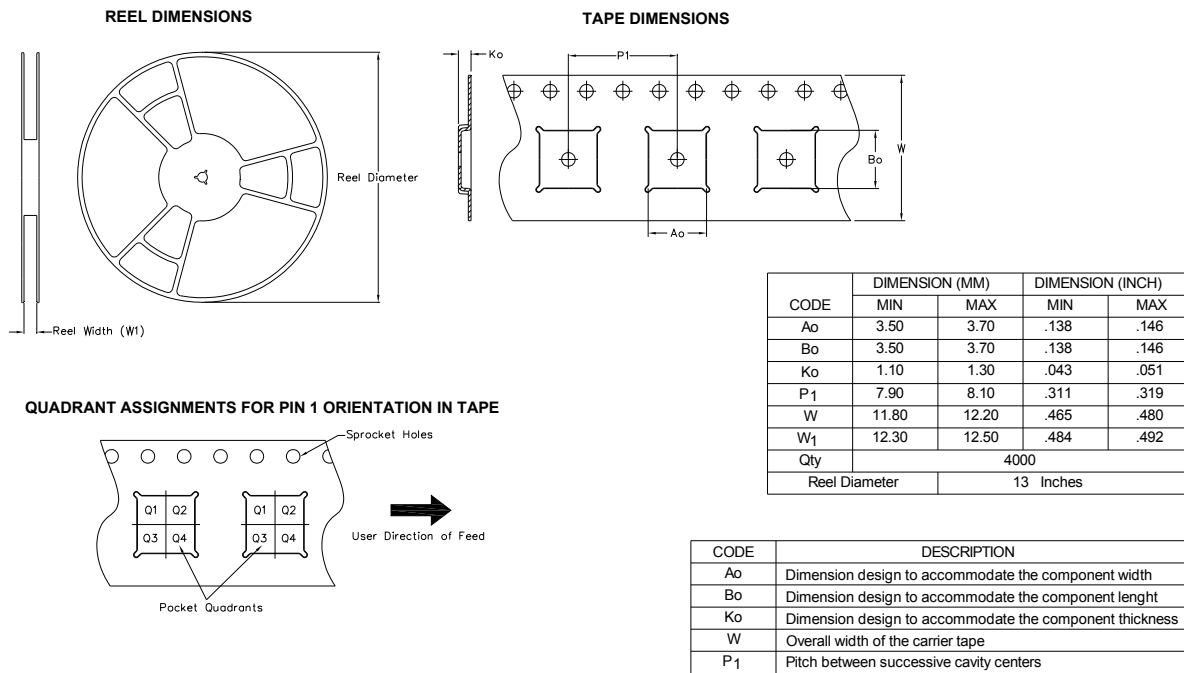
**PQFN 3.3 x 3.3 Tape and Reel**

Note: For the most current drawing please refer to IR website at <http://www.irf.com/package/>



**Qualification Information<sup>†</sup>**

<b>Qualification Level</b>	Industrial (per JEDEC JESD47F <sup>††</sup> guidelines)	
<b>Moisture Sensitivity Level</b>	PQFN 3.3mm x 3.3mm	MSL1 (per JEDEC J-STD-020D <sup>††</sup> )
<b>RoHS Compliant</b>	Yes	

† Qualification standards can be found at International Rectifier’s web site: <http://www.irf.com/product-info/reliability>

†† Applicable version of JEDEC standard at the time of product release.

**Notes:**

- ① Repetitive rating; pulse width limited by max. junction temperature.
- ② Starting  $T_J = 25^{\circ}\text{C}$ ,  $L = 2.06\text{mH}$ ,  $R_G = 50\Omega$ ,  $I_{AS} = 6.3\text{A}$ .
- ③ Pulse width  $\leq 400\mu\text{s}$ ; duty cycle  $\leq 2\%$ .
- ④  $R_{\theta}$  is measured at  $T_J$  of approximately  $90^{\circ}\text{C}$ .
- ⑤ When mounted on 1 inch square PCB (FR-4). Please refer to AN-994 for more details:  
<http://www.irf.com/technical-info/appnotes/an-994.pdf>
- ⑥ Calculated continuous current based on maximum allowable junction temperature.
- ⑦ Current is limited to 20A by source bonding technology.

**Revision History**

Date	Comments
6/5/14	<ul style="list-style-type: none"> <li>• Updated schematic on page 1</li> <li>• Updated tape and reel on page 8</li> </ul>
7/1/14	<ul style="list-style-type: none"> <li>• Remove “SAWN” package outline on page 7.</li> </ul>