

One-cell Lithium Battery Protection IC

General Description

The EC9526A battery protection IC is designed to protect lithium-ion / polymer battery from damage or degrading the lifetime due to over current for one-cell lithium-ion / polymer battery powered systems. such as cellular phones . The ultra-small package and less required external components make it ideal to integrate the EC9526A into the limited space of battery pack. The accurate $\pm 50\text{mV}$ overcharging detection voltage ensures safe and full utilization charging. The very low standby current drains little current from the cell while in storage .

Features

◆ High-accuracy voltage detection circuit

Overcharge detection voltage	3.6V to 4.4V	Accuracy $\pm 50\text{mV}$
Overcharge release voltage	3.6V to 4.4V	Accuracy $\pm 50\text{mV}$
Overdischarge detection voltage	2.0V to 3.0V	Accuracy $\pm 100\text{mV}$
Overdischarge release voltage	2.0V to 3.4V	Accuracy $\pm 100\text{mV}$
Discharge overcurrent detection voltage	0.05V to 0.3V	Accuracy $\pm 30\text{mV}$
Load short-circuiting detection voltage	1.1V	Accuracy $\pm 200\text{mV}$

◆ Detection delay times are generated by an internal circuit
(external capacitors are unnecessary)

Overcharge detection delay time	Typical. 100ms
Overdischarge detection delay time	Typical. 100ms
Discharge overcurrent detection delay time	Typical. 10ms
Load short-circuiting detection delay time	Typical 450 μs

◆ High voltage tolerance is used for charger connection pins, VM and CO pins are absolute maximum rating = 28V

◆ 0V battery charge function available

◆ Wide operation temperature range -40 ~ +85 $^{\circ}\text{C}$

◆ Low current consumption

Operation mode Typ. 2.4 μA / Max. 6.0 μA (25 $^{\circ}\text{C}$)

Standby mode Max. 0.1 μA (25 $^{\circ}\text{C}$)

Self-recovery function Max. 3.0 μA (25 $^{\circ}\text{C}$)

◆ Small package SOT23-6L

◆ Lead-free / Green product

One-cell Lithium Battery Protection IC

Applications

- ◆ Protection IC for One-Cell Lithium-ion
- ◆ Lithium-Polymer Rechargeable Battery Packs

Block Diagram

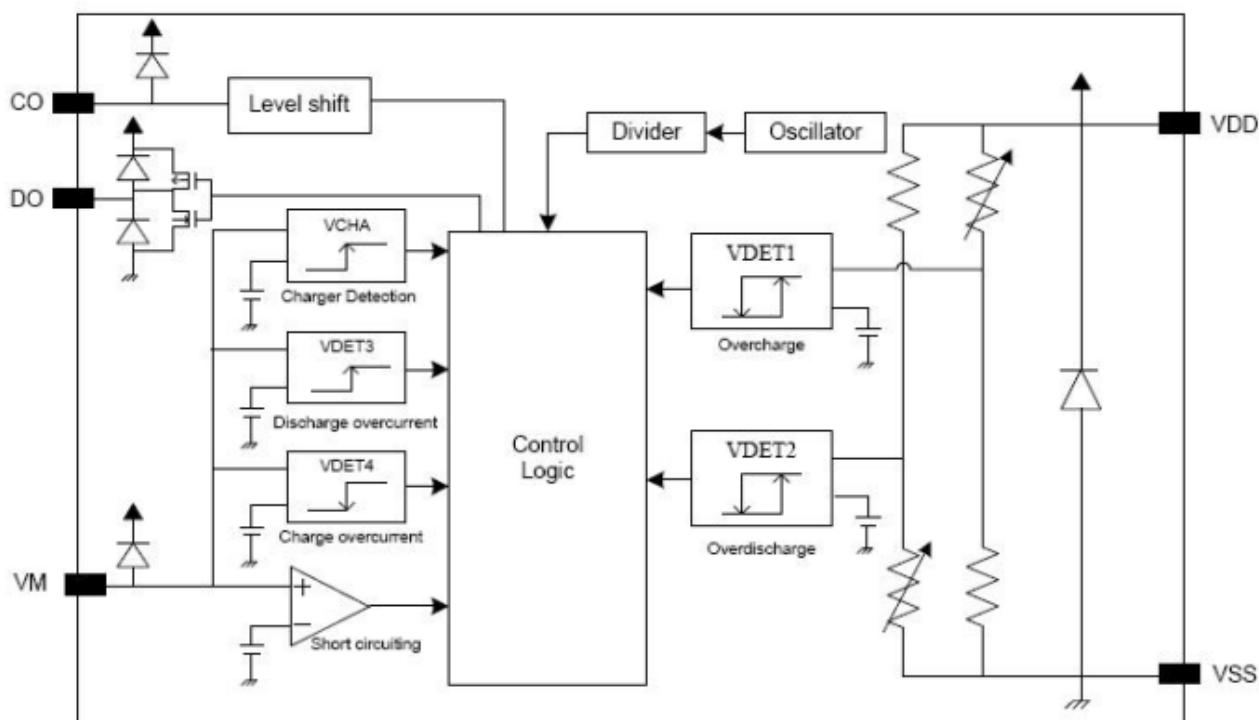

Ordering Information

EC9526AN XX X

R : Tape & Reel

Package Type :
B3=SOT23-6L

Package	Part Number	Marking	Marking Information
SOT23-6L	EC9526ANB3R	9526A LLLLL	LLLLL : Lot No

One-cell Lithium Battery Protection IC

Absolute Maximum Ratings ($V_{SS}=0V$, $T_a=25^{\circ}C$ unless otherwise specified)

	Symbol	Rating	Unit
Input voltage between V_{DD} and V_{SS}	V_{DD}	$V_{SS} = -0.3 \sim V_{SS} = +12$	V
VM pin input voltage	V_M	$V_{DD} - 28 \sim V_{DD} + 0.3$	V
DO pin output voltage	V_{DO}	$V_{SS} - 0.3 \sim V_{DD} + 0.3$	V
CO pin output voltage	V_{CO}	$V_{DD} - 28 \sim V_{DD} + 0.3$	V
Electrical static discharge	HBM	2	KV
	MM	200	V
Operating Temperature Range	T_{OPR}	- 40 ~ + 85	$^{\circ}C$
Storage Temperature Range	T_{STG}	- 55 ~ + 125	$^{\circ}C$

Remarks: Any operation condition exceeds the absolute maximum ratings will damage the IC.

Product Name List

Product	Over charge Detection Voltage [V_{det1}]	Over charge Release Voltage [V_{rel1}]	Over discharge Detection Voltage [V_{det2}]	Over discharge Release Voltage [V_{rel2}]	Discharge overcurrent Detection Voltage [V_{det3}]	0V Battery Charge Function	Mode Selection
EC9526ANB3R	4.3V \pm 0.050V	4.1V \pm 0.050V	2.4V \pm 0.100V	3.0V \pm 0.100V	140mV \pm 30mV	Available	Auto- recovery

One-cell Lithium Battery Protection IC

Electrical Characteristics (TA = 25°C unless otherwise specified)

Item	Symbol	Test Condition	Min.	Typ.	Max.	Unit	Test
Operating voltage between VDD & VSS	VDD		1.5	-	10.0	V	A
Operating voltage between CO & VM			1.5	-	25.0	V	A
Minimum operating voltage for 0V charging	Vst	VDD-VM, VDD-VSS=0V	-	-	1.2	V	B
Discharging overcurrent release resistance	Rshort	VDD=3.6,VM=1.0V	30	50	100	KΩ	C
CO pin Nch ON voltage	VCOL		-	0.4	0.5	V	D
CO pin Pch ON voltage	VCOH		VDD-0.1	VDD-0.02	-	V	D
DO pin Nch ON voltage	VDOL		-	0.2	0.5	V	D
DO pin Pch ON voltage	VDOH		VDD-0.1	VDD-0.02	-	V	D
Current consumption	IDD	VDD=3.5V,VM=0V	1.2	2.4	6.0	uA	C
Overdischarge current consumption (Self-recovery)	IDOX	VDD=2.0V		1,8	3.0	uA	C

DETECTION VOLTAGE

Item	Symbol	Test Condition	Min.	Typ.	Max.	Unit	Test
Overcharge detection voltage	Vdet1	R1=100Ω	4.250	4.300	4.350	V	A
Overcharge release voltage	Vrel1	R1=100Ω	4.050	4.100	4.150	V	A
Overcharge hysteresis voltage	Vhys1	R1=100Ω Vhys1=Vdet1-Vrel1	-	0.200	-	V	A
Overdischarge detection voltage	Vdet2	VM=0V,R1=100Ω	2.300	2.400	2.500	V	A
Overdischarge release voltage	Vrel2	R1=100Ω	2.900	3.000	3.100	V	A
Overdischarge release voltage2	Vrel2'	R1=100Ω, R2=1.0kΩ, VM=Vchg	2.300	2.400	2.500	V	A
Discharging overcurrent detection voltage	Vdet3	VDD=3.0V, R2=1.0kΩ	0.110	0.140	0.170	V	B
Short detection voltage	Vshort	VDD=3.0V	1.30	1.10	0.90	V	B

One-cell Lithium Battery Protection IC

Electrical Characteristics (TA = 25°C unless otherwise specified)

DELAY TIME

Item	Symbol	Test Condition	Min.	Typ.	Max.	Unit	Test
Overcharge detection delay time	T _{Vdet1}	VDD=3.8V→4.5V	50	100	200	ms	E
Overcharge release delay time	T _{Vrel1}	VDD=4.5V→3.8V	-	0.7	-	ms	E
Overdischarge detection delay time	T _{Vdet2}	VDD=3.2V→2.2V	50	100	200	ms	E
Overdischarge release delay time	T _{Vrel2}	VDD=2.2V→3.3V	-	0.7	-	ms	E
Discharging overcurrent detection delay time	T _{Vdet3}	VDD=3.0V, VM=0V→0.2V	5	10	20	ms	E
Discharging overcurrent release delay time	T _{Vrel3}	VDD=3.0V, VM=0.2V→0V	-	0.7	-	ms	E
Short detection delay time	T _{short}	VDD=3.5V, VM=0V→1.0V	250	400	750	us	E
Charger detection voltage	V _{chg}	VDD=3.6V, R2=1.0kΩ	0.3	0.7	1.1	V	

Pin Configuration

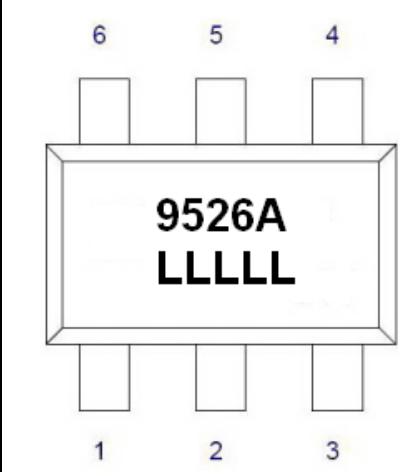
Package	Pin No.	Symbol	Description
	1	DO	Over-discharge MOSFET Gate control terminal
	2	VM	Input terminal connect to charger and system ground
	3	CO	Over-charge MOSFET Gate control terminal
	4	NC	No connection
	5	VDD	Battery positive terminal
	6	VSS	Battery negative terminal

One-cell Lithium Battery Protection IC

Type Application Circuit

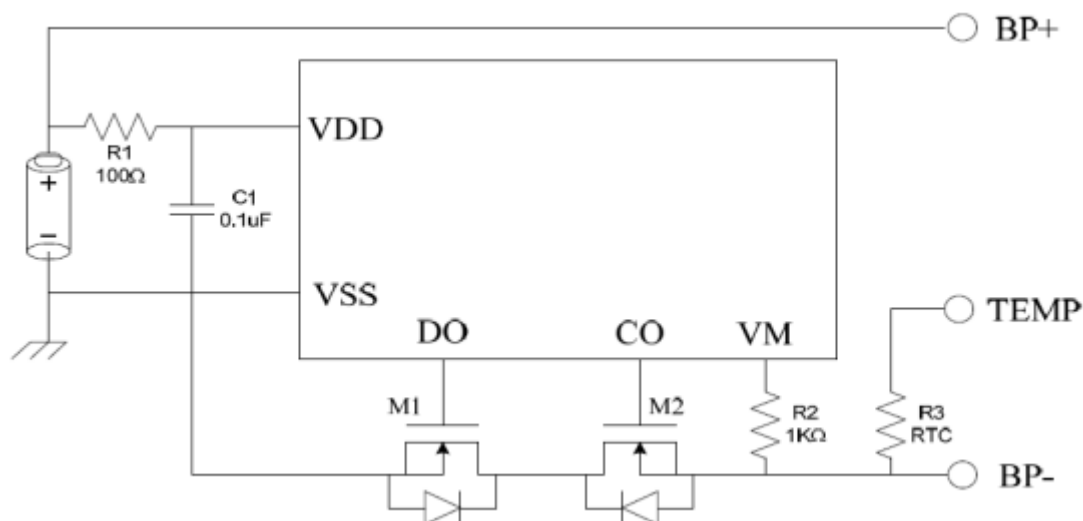

Discrete	Components	Function	Min.	Typ.	Max.	Unit	Remarks
R1	Resistor	Current limit noise filtering	--	100	1K	Ω	*1
R2	Resistor	Current limit ESD protection	300	1K	2K	Ω	*4
R3	Thermistor	Temp. protection	--	--	00	kΩ	
C1	Capacitor	Noise filtering	0.022	0.1	1.0	uF	*3
M1	N-MOSFET	Discharge switch					*2
M2	N-MOSFET	Charge switch					*2

*1 : R1 is a single-stage RC filter , the higher resistance of R1 , the better the filtering effect , If the R1 resistance higher than the recommended value , it will affect the internal detection circuit and the voltage detection accuracy will out of specification. We suggest using the recommended resistance in application.

*2 : The absolute maximum rating of CO and VM is 28V, customer could choose 20V or 30V dual N-MOSFET switches for different application.

*3 : Add a C1 capacitor between VDD and VSS could filter conduction and radiation noise.

*4 : R2 resistor could have a current limit function and limit charger current surge.

One-cell Lithium Battery Protection IC

Normal Operation

The EC9526A monitors the V_{DD} power supply voltage relative to V_{SS} detecting the over-charge and over-discharge conditions. It also monitors the VM voltage to detect the discharge over-current and load short circuiting to protect the battery cell. In normal operation, the V_{DD} should be in the range from the over-charge detection voltage V_{det1} to the over-discharge voltage V_{det2} , and the VM pin voltage is in the range from discharge over-current voltage V_{det3} to charger detection voltage V_{CHA} . In normal condition, the internal pull-up resistor from VM pin to VDD (R_{VMD}) is disconnected and the internal pull-down resistor (R_{VMS}) from VM pin to VSS is also disconnected.

Notice: Discharging may not be enacted when the battery is first time connected. To regain normal status, VM and VSS terminal must be shorted or the charger must be connected.

Over-Charge Condition

When the battery voltage is greater than over-charge voltage (V_{det1}) and have a TV_{det1} time duration from a normal operation condition, the over-charge condition hold and the CO pin will output from logic "H" to logic "L" to disconnect the battery charging path. It will turn-off the external MOSFET and the charging status stopped.

It will release the over-charge condition in the following conditions. If the battery voltage less than V_{rel1} from the over-charge condition, the CO will output logic "H" to turn on the external MOSFET to resume the charging path. In the over-charge condition, the discharge over-current and load short circuiting function will be disabled until the battery voltage falls below the overcharge detection voltage. It is because that the internal resistance of battery which will trigger the discharge over-current and load short circuiting function in the time when over-charge condition enabled.

In over-charge condition, the internal pull-up resistor from VM pin to VDD (R_{VMD}) is disconnected and the internal pull-down resistor (R_{VMS}) from VM pin to VSS is also disconnected.

Over-Discharge Condition

The EC9526A single-cell lithium protect IC monitors the VDD voltage to detect the over-discharge state from normal operation condition. If the VDD voltage becomes lower than the V_{det2} and continues for the over-discharge delay time TV_{det2} from normal operation condition, the DO pin will output "L" to disable the external MOSFET and the discharging stopped.

If a charger is connected and the VDD voltage is greater than over-discharge release voltage V_{rel2} , the over-discharge condition released. In over-discharge condition, the charging path is connected by the parasitic diode of discharge controlled MOSFET.

When a battery in the over-discharge condition, if VDD is greater than V_{rel2} and the VM is higher than V_{CHA} , the over-discharge condition is released. When a battery in the over-discharge condition, if VDD is greater than V_{det2} and the VM is lower than V_{CHA} , the over-discharge condition is released.

When the over-discharge condition hold, and the voltage difference between VM and VDD is less than 1.3V, the current consumption is reduced to the power-down current consumption 0.1uA in typical.

In over-discharge condition, the VM pin is connected to VDD by internal pull-up resistor R_{VMD} and the internal pull-down resistor (R_{VMS}) from VM pin to VSS is disconnected.

When the MOSFET is off, VM pin voltage is pulled up by the resistor to VDD in the IC, at this time, the power consumption is reduced to the lowest. This condition is called the "Green MODE".

Over-current Condition

There are 3 kinds of over-current condition. One is the discharge over-current condition and another is the load short-circuiting condition and the other is charge over-current condition.

The EC9526A monitors the VM pin voltage to detect the over-current and load short-circuiting condition. If VM pin voltage is greater than V_{det3} and continues to discharge over-current delay time TV_{det3} , the over-current condition enabled and the DO pin output logic "L" to disable the discharging path. At the same time, the discharging is stopped.

In over-current condition, the internal pull-up resistor from VM pin to VDD (R_{VMD}) is disconnected and the VM pin is connected to VSS by internal pull-down resistor R_{VMS} . However, the VM pin is pull-up to VDD by external load resistor.

When the load is disconnected, the VM pin is pull-down to VSS by internal resistor.

If the VM pin voltage falls below the charger detection voltage V_{CHA} under normal condition, and it continues and longer than the overcharge detection delay time TV_{det1} , the CO pin will disable the charging path by disconnected the charge controlled MOSFET. The charge over-current detection is released when the voltage difference between VM pin and VSS becomes less than charger detection voltage V_{CHA} .

Timing Diagram

1. Over-charge voltage detection/release & Over-discharge voltage detection / release

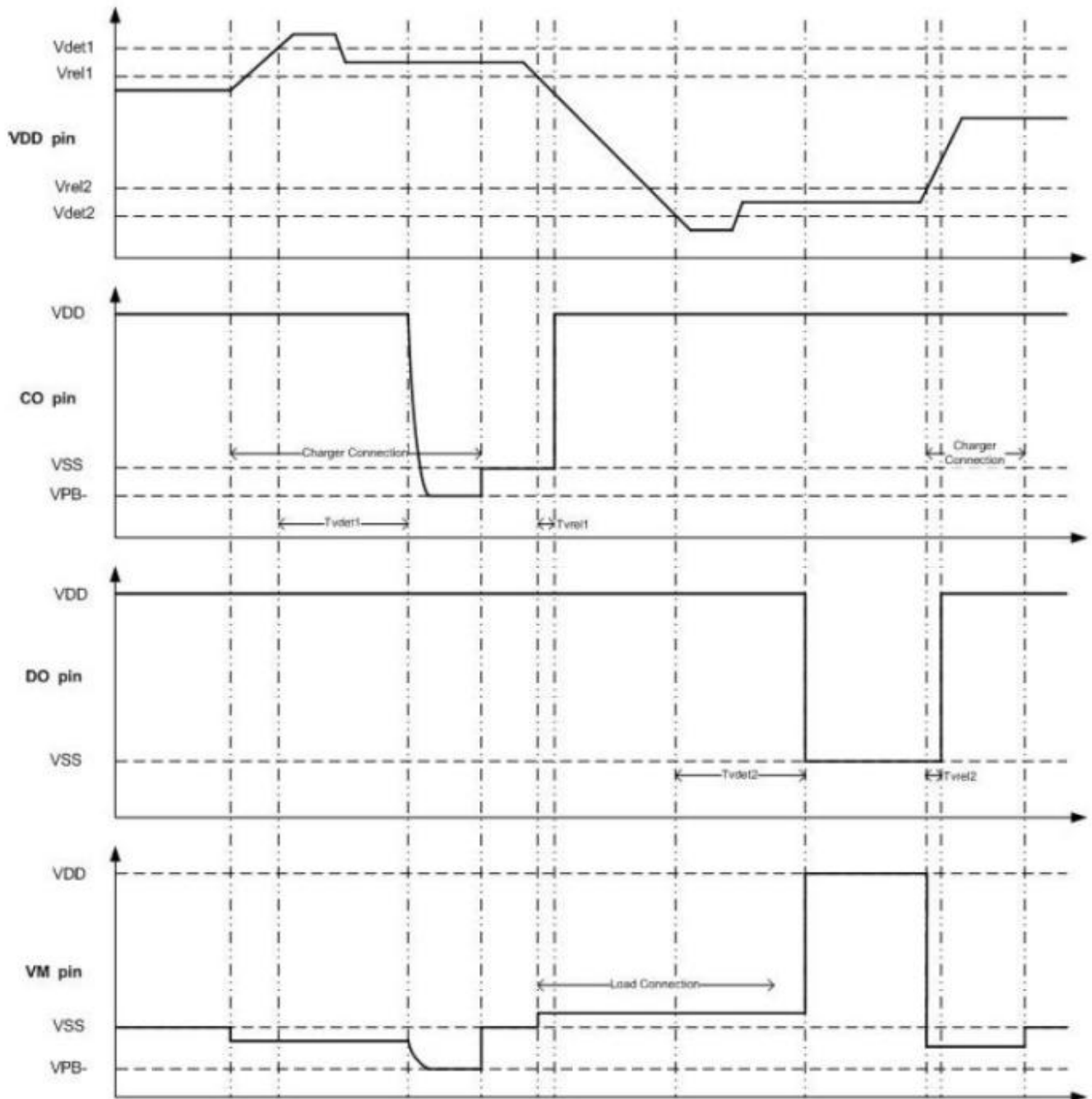

2. Dis-charge over current detection & Load short circuiting detection

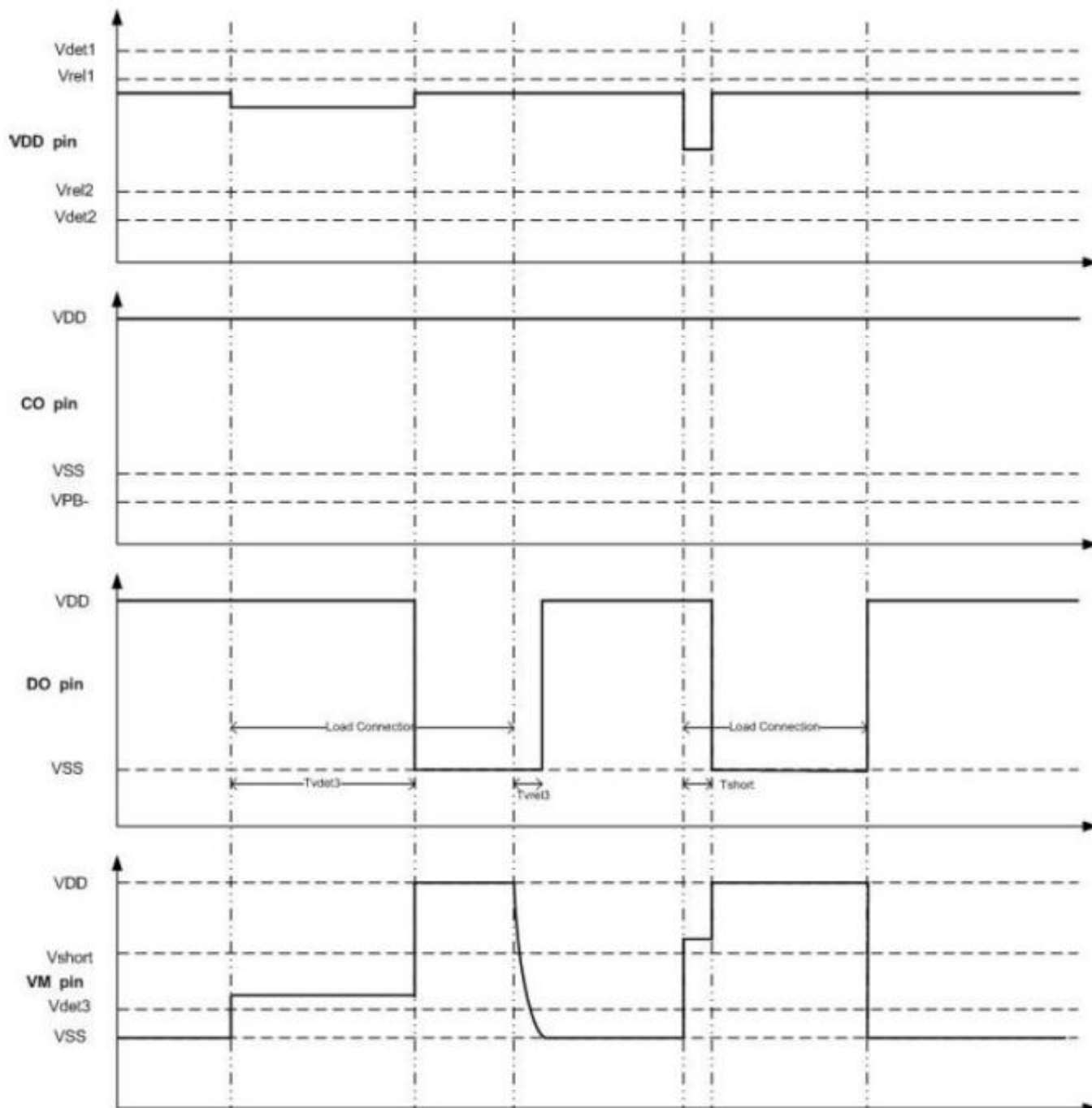

Package Outline

SOT23-6L

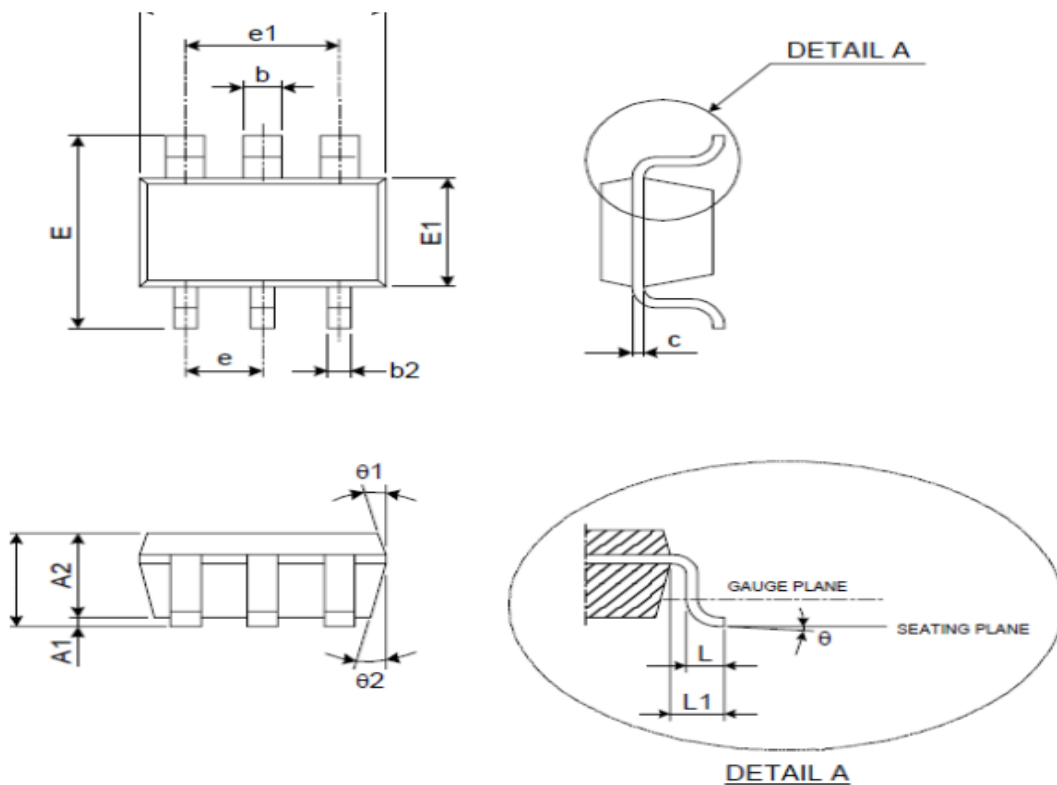

Unit : mm

SYMBOL	MIN.	TYP.	MAX.
A	1.05	-	1.35
A1	0.05	-	0.15
A2	1.00	1.10	1.20
b	0.40	-	0.55
b2	0.25	-	0.40
c	0.08	-	0.20
D	2.70	2.90	3.00
E	2.60	2.80	3.00
E1	1.50	1.60	1.70
L	0.35	0.45	0.55
L1	0.60 REF.		
e	0.95 BSC.		
e1	1.90 BSC.		
θ	0°	5°	10°
θ_1	3°	5°	7°
θ_2	6°	8°	10°