

## RF Power Barrel Capacitors with Screw Terminals, Class 1 and Class 2 Ceramic



QUICK REFERENCE DATA		
DESCRIPTION	VALUE	
Ceramic Class	1	2
Ceramic Dielectric	C0G, U2J, N5600	X7R, Y5U
Type	TOS 020016	
Voltage (V <sub>p</sub> )	7500	7500
Min. Capacitance (pF)	10	400
Max. Capacitance (pF)	300	2500
Mounting	Screw terminal	

### MATERIAL

Capacitor elements made from class 1 ceramic dielectric with noble metal electrodes.

Connection terminals:  
thread terminal, brass, silver plated.

Allowable torque: 1.47 Nm (13 lbf in)

### FINISH

Capacitor body completely protective lacquered.

### MARKING

Type designator, capacitance value and tolerance, rated peak voltage, ceramic material code, production date code, manufacturer logo.

### FEATURES

- Small size
- Geometry minimizes inductance, optimizes voltage withstand and maximizes heat radiation

### APPLICATIONS

- Industrial and medical RF power supply
- Small broadcasting equipment
- Antenna couplers
- Induction heating equipment

### CAPACITANCE RANGE

10 pF to 2.5 nF

### CAPACITANCE TOLERANCE

- Class 1: ± 10 %
- Class 2: ± 20 %

### CERAMIC DIELECTRICS

- Class 1: C0G, U2J, N5600
- Class 2: X7R, Y5U

### RATED VOLTAGE

7.5 kV<sub>DC</sub>

### DIELECTRIC STRENGTH TEST

150 % of rated voltage (8000 V<sub>RMS</sub>, 50 Hz, 3 minutes)

### DISSIPATION FACTOR

- C0G, U2J: max. 0.05 % (1 MHz)
- N5600: max. 0.20 % (1 MHz)
- X7R, Y5U: max. 2.5 % (1 kHz)

### INSULATION RESISTANCE

- C0G, U2J, N5600, X7R: min. 100 000 MΩ (at 25 °C)
- Y5U: min. 50 000 MΩ (at 25 °C)

### OPERATING TEMPERATURE RANGE

- Class 1: -55 °C to +100 °C
- Class 2: -55 °C to +85 °C

SAP PART NUMBER AND ELECTRICAL DATA									
PART NUMBER	CERAMIC	CAP. VALUES (pF)	RATED VOLTAGE (kV <sub>DC</sub> )	MAX. POWER RATING <sup>(1)</sup>			MAX. CURRENT RATING		
				1.0 MHz (kvar)	10 MHz (kvar)	30 MHz (kvar)	1.0 MHz (A <sub>RMS</sub> )	10 MHz (A <sub>RMS</sub> )	30 MHz (A <sub>RMS</sub> )
BS020016VZ10036AC1	C0G (NPO)	10	7.5	1.7	10	10	0.3	2.5	4.3
BS020016VZ15036AC1		15		3.2	10	10	0.6	3.1	5.3
BS020016VZ25036AC1		25		4.4	10	10	0.8	4.0	6.9
BS020016VZ30036AC1		30		5.3	10	10	1.0	4.4	7.5
BS020016VZ40036AC1		40		7.0	10	10	1.3	5.1	8.7
BS020016VZ50036AC1		50		8.8	10	10	1.7	5.6	9.7
BS020016VZ75036AL1	U2J (N750)	75		10	10	7.0	2.2	6.9	10
BS020016VZ10136AL1	(N750)	100		10	10	5.3	2.5	7.9	10
BS020016VZ15136AS1	N5600	150		5.0	5.0	3.5	2.2	6.9	10
BS020016VZ20136AS1		200		5.0	5.0	2.7	2.5	7.9	10
BS020016VZ30136AS1		300		5.0	5.0	1.8	3.1	9.7	10
BS020016VZ40138AT1	X7R	400		0.4	0.4	0.4	1.0	3.2	5.5
BS020016VZ50138AT1		500		0.4	0.4	0.4	1.1	3.6	6.1
BS020016VZ60138AU1		600		0.4	0.4	0.4	1.2	3.9	6.7
BS020016VZ80138AU1		800		0.4	0.4	0.4	1.4	4.5	7.8
BS020016VZ10238AV1		1000		0.2	0.2	0.2	1.1	3.6	6.1
BS020016VZ15238AV1		1500		0.2	0.2	0.2	1.4	4.3	7.5
BS020016VZ20238BA1	Y5U	2000		0.2	0.2	0.2	1.6	5.0	8.7
BS020016VZ25238BA1		2500		0.2	0.2	0.2	1.8	5.6	9.7

**Notes**

- # 14<sup>th</sup> to 15<sup>th</sup> digit: capacitance tolerance code ± 10 % = 36; ± 20 % = 38
- RoHS-compliant parts on request
- <sup>(1)</sup> The surface temperature during operation must not exceed +100 °C

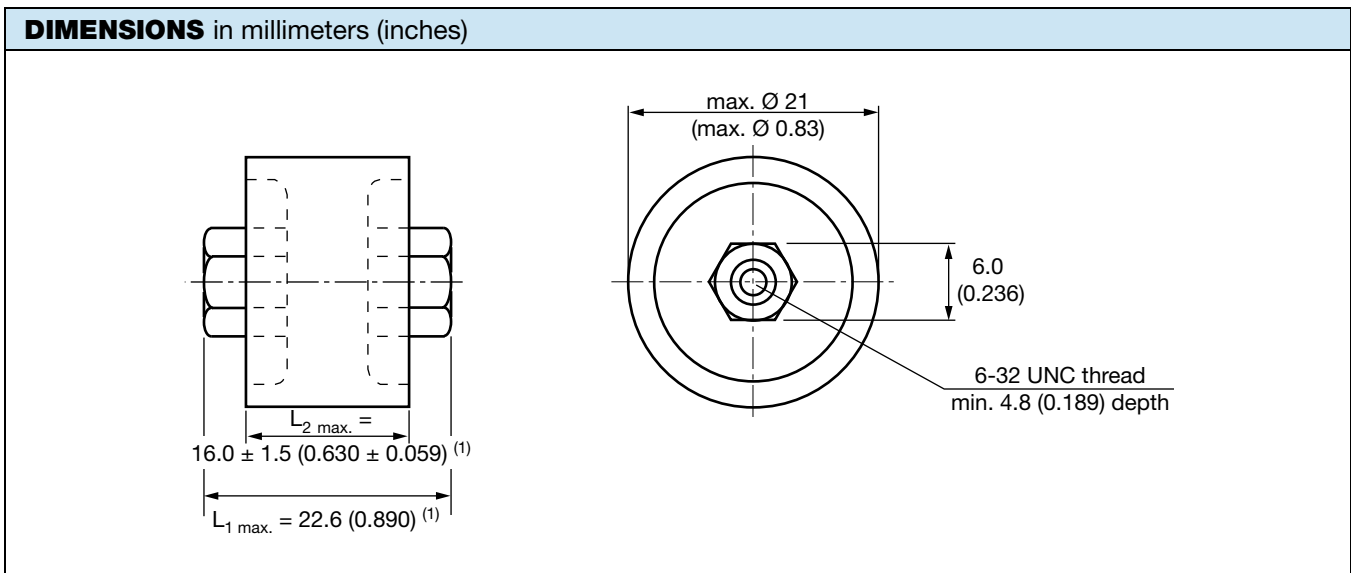
**Note**

- <sup>(1)</sup> Dimension L<sub>1</sub> and L<sub>2</sub> will vary depending upon capacitance value

RELATED DOCUMENTS	
General Information	<a href="http://www.vishay.com/doc?22071">www.vishay.com/doc?22071</a>



## **Disclaimer**

ALL PRODUCT, PRODUCT SPECIFICATIONS AND DATA ARE SUBJECT TO CHANGE WITHOUT NOTICE TO IMPROVE RELIABILITY, FUNCTION OR DESIGN OR OTHERWISE.

Vishay Intertechnology, Inc., its affiliates, agents, and employees, and all persons acting on its or their behalf (collectively, "Vishay"), disclaim any and all liability for any errors, inaccuracies or incompleteness contained in any datasheet or in any other disclosure relating to any product.

Vishay makes no warranty, representation or guarantee regarding the suitability of the products for any particular purpose or the continuing production of any product. To the maximum extent permitted by applicable law, Vishay disclaims (i) any and all liability arising out of the application or use of any product, (ii) any and all liability, including without limitation special, consequential or incidental damages, and (iii) any and all implied warranties, including warranties of fitness for particular purpose, non-infringement and merchantability.

Statements regarding the suitability of products for certain types of applications are based on Vishay's knowledge of typical requirements that are often placed on Vishay products in generic applications. Such statements are not binding statements about the suitability of products for a particular application. It is the customer's responsibility to validate that a particular product with the properties described in the product specification is suitable for use in a particular application. Parameters provided in datasheets and / or specifications may vary in different applications and performance may vary over time. All operating parameters, including typical parameters, must be validated for each customer application by the customer's technical experts. Product specifications do not expand or otherwise modify Vishay's terms and conditions of purchase, including but not limited to the warranty expressed therein.

Except as expressly indicated in writing, Vishay products are not designed for use in medical, life-saving, or life-sustaining applications or for any other application in which the failure of the Vishay product could result in personal injury or death. Customers using or selling Vishay products not expressly indicated for use in such applications do so at their own risk. Please contact authorized Vishay personnel to obtain written terms and conditions regarding products designed for such applications.

No license, express or implied, by estoppel or otherwise, to any intellectual property rights is granted by this document or by any conduct of Vishay. Product names and markings noted herein may be trademarks of their respective owners.