

▲ CIRCUIT: SPST

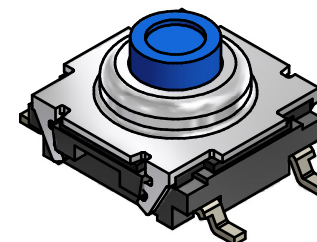

NOTES

1. ALL DIMENSIONS IN MM [INCH]
2. GENERAL TOLERANCE: X.X=± 0.4
X.XX=± 0.25
3. TERMINAL NUMBERS FOR REF. ONLY.
- ▲ 4. OPERATING FORCE: 300 ± 50gf
5. OPERATING LIFE: 500,000 CYCLES (B)
6. TRAVEL: 0.5 ± 0.15mm
7. CONTACT RATING: 12VDC @ 50mA
8. CONTACT RESISTANCE: 100m Ω MAX
9. INSULATION RESISTANCE: 100M Ω MIN @ 100VDC.
- ▲ 10. CONTACT MATERIAL: SILVER
11. OPERATING TEMPERATURE: -40°C TO 85°C
12. PACKAGING: TAPE & REEL, 700 PCS. PER REEL
13. ▲ DENOTES CRITICAL PARAMETER
14. 2002/95/EC (ROHS) COMPLIANT
- ▲ 15. ACTUATOR COLOR: CUSTOM BLUE PER PMS 2727C

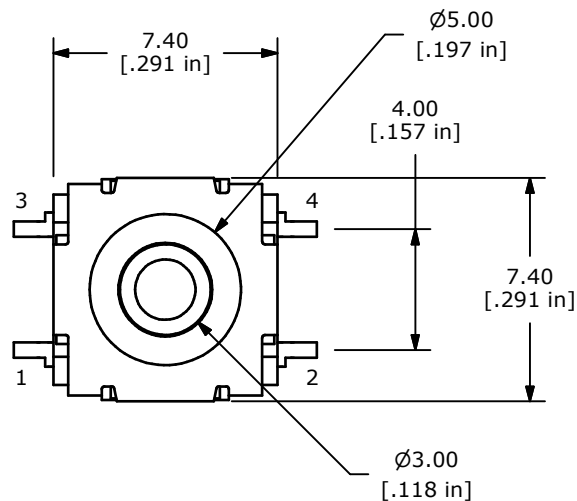
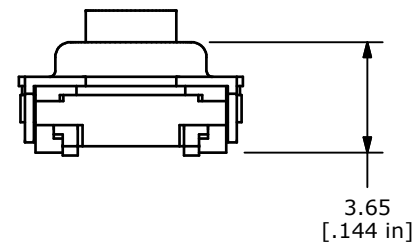
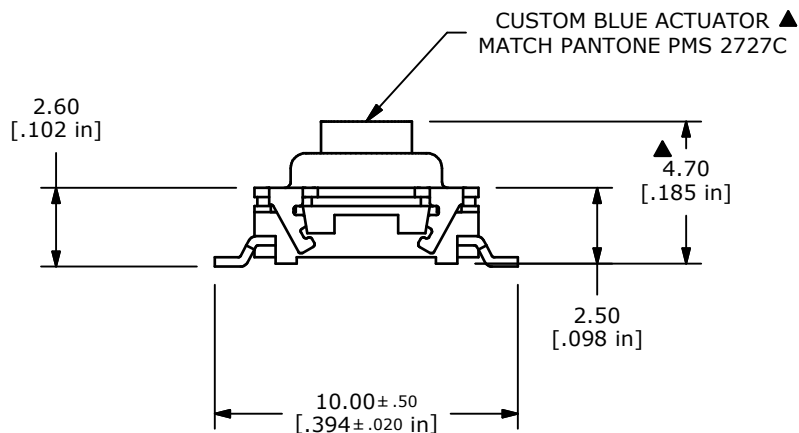

TITLE TL6120AF300QGBLU				
SCALE	DATE	DR	DWG	REV
	6/3/2013	EBP	T351522	B

THE INFORMATION CONTAINED IN THIS DOCUMENT IS PROPRIETARY TO E-SWITCH AND IS NOT TO BE COPIED OR TRANSFERRED