

SMD Clock Oscillator

High performance clock oscillator in low profile 2.5 x 2.0 mm surface mount plastic package.



Product description

The RXO2520S performance clock oscillator delivers high performance with low jitter and tight stability over an extended temperature range in low height profile QFN packages with an industry standard 2.5 x 2.0 mm footprint. 2000+ frequency configurations are available for immediate sampling and short production lead time reduces inventory levels.

Applications

- Automotive
- Communications
- Consumer
- PCI Express
- PON/EPON/GPON/GEAPON
- DSL/ADSL
- Ethernet
- Serial Rapid I/O (SRIO)
- Storage Networks
- Servers

Features

- Extended temperature range
- Fast sample turnaround
- CMOS, LVPECL, LVDS, or HCSL output options
- Wide frequency range
- Tight frequency stability

Specifications

1.0 SPECIFICATION REFERENCES

Line	Parameter	Description
1.1	Model Description	RXO2520S
1.2	Reference Number	
1.3	Rakon Part Number	

2.0 FREQUENCY CHARACTERISTICS

Line	Parameter	Test Condition	Value	Unit
2.1	Frequency Range		10 to 460	MHz
2.2	Operating Temperature Range	-55°C to 125°C upon request	-40 to 85	°C
2.3	Frequency Stability	Including initial tolerance, Temperature range, Supply variation, Load variation and 10 years aging at 25°C	±25 to 100	ppm
2.4	Temperature Stability	Temperature range only	±10 to 25	ppm

3.0 POWER SUPPLY

Line	Parameter	Test Condition	Value	Unit
3.1	Supply Voltage (VDD)	With a tolerance of ±10%	3.3	V
3.2	Supply Voltage (VDD)	With a tolerance of ±10%	2.5	V
3.3	Supply Current	For LVCMOS	40 max	mA
3.4	Supply Current	For LVPECL	65 max	mA
3.5	Supply Current	For LVDS	40 max	mA
3.6	Supply Current	For HCSL	50 max	mA

4.0 OUTPUT CHARACTERISTICS - LVCMOS (UP TO 170 MHz)

Line	Parameter	Test Condition	Value	Unit
4.1	Output Voltage (Vol)	15pF load	10 max	%VDD
4.2	Output Voltage (Voh)	15pF load	90 min	%VDD
4.3	Duty Cycle	Measured at 1.25V	45 to 55	%
4.4	Rise Time/Fall Time	80%/20%	0.6 max	ns
4.5	RMS Phase Jitter	Integrated 12 kHz to 20 MHz at 156.25 MHz	2 max	ps

5.0 OUTPUT CHARACTERISTICS - LVPECL ONLY

Line	Parameter	Test Condition	Value	Unit
5.1	Output Voltage (Vol)	50Ω nominal load. (VDD - 1.55V) max.		
5.2	Output Voltage (Voh)	50Ω nominal load. (VDD - 1.08V) min.		
5.3	Duty Cycle	Measured at 1.25V	48 to 52	%
5.4	Rise Time/Fall Time	80%/20%	0.6 max	ns
5.5	RMS Phase Jitter	Integrated 12 kHz to 20 MHz at 156.25 MHz	2 max	ps

6.0 OUTPUT CHARACTERISTICS - LVDS ONLY

Line	Parameter	Test Condition	Value	Unit
6.1	Differential Output: Voltage Swing (Vod)		350	mV
6.2	Duty Cycle	Measured at 1.25V	48 to 52	%
6.3	Rise Time / Fall Time	RL = 50 Ω / CL = 2 pF	0.6 max	ns
6.4	RMS Phase Jitter	Integrated 12 kHz to 20 MHz at 156.25 MHz	2 max	ps

7.0 OUTPUT CHARACTERISTICS - HCSL ONLY

Line	Parameter	Test Condition	Value	Unit
7.1	Output Voltage (Vol)		0.1 max	V
7.2	Output Voltage (Voh)		0.725 min	V
7.3	Duty Cycle		48 to 52	%
7.4	Rise Time/Fall Time	80%/20%	0.6 max	ns
7.5	RMS Phase Jitter	Integrated 12 kHz to 20 MHz at 100 MHz	2 max	ps

8.0 PIN CONNECTIONS

Line	Parameter	Description
8.1	Pin 1	E/D* or NC
8.2	Pin 2	NC
8.3	Pin 3	GND
8.4	Pin 4	OUTPUT
8.5	Pin 5	COMPLIMENTARY OUTPUT (LVPECL/LVDS/HCSL only), or NC
8.6	Pin 6	VDD
8.7	* Output Enable	>75% of VDD on E/D, or NC pin
8.8	* Output Disable	<25% of VDD on E/D, or NC pin

9.0 PACKAGE DETAILS

Line	Parameter	Description
9.1	Top line	[R#####] Part identifier
9.2	Middle line	[FFYYWW] FFF=factory information, YY=last two digits of the year, WW=A two digit week number
9.3	Bottom line	[o LLLL] Dot=pin 1 indicator, LLLL=lot code

10.0 ENVIRONMENTAL SPECIFICATION

Line	Parameter	Description
10.1	Mechanical Shock	MIL-STD-883, Method 2002
10.2	Storage Temperature Range	-55 to 150 °C
10.3	Humidity	After 48 hours at 85 °C ±2 °C 85 % relative humidity non-condensing
10.4	Thermal Shock	MIL-STD-883, Method 1011
10.5	Vibration	MIL-STD-883, Method 2007
10.6	Gross and Fine Leak	MIL-STD-883, Method 1014
10.7	RoHS Compliant	Yes
10.8	Halogen Free	Yes
10.9	REACH Compliance	Yes (EC Regulation No. 1907/2006)

11.0 MANUFACTURING INFORMATION

Line	Parameter	Description
11.1	Packaging Description	Tape and Reel. Standard packing quantity is 1000 per D180 mm reel
11.2	Reflow	Solder reflow process as per attached profile

Preliminary

Drawing Name: XO/VCXO 2520S 6P Model (Package Z)

MODEL DRAWING:

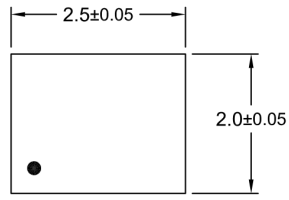

1
TOP VIEW



FRONT VIEW

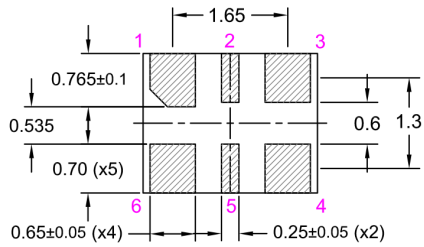

BOTTOM VIEW

NOTE:

1. MARKING INFORMATION IS DETAILED IN THE SPECIFICATION.
2. PIN CONNECTIONS ARE DETAILED IN THE SPECIFICATION.

RECOMMENDED 6 PAD LAYOUT - TOP VIEW:

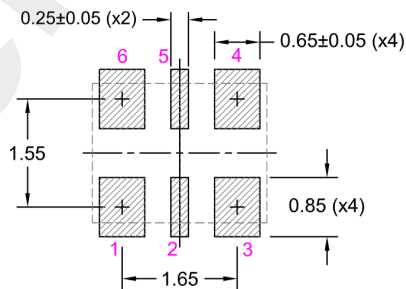

TITLE: XO/VCXO 2520 6P MODEL (Package Z)

RELATED DRAWINGS:

FILENAME: CAT766

REVISION: B

DATE: 06-Mar-13

SCALE: 10 : 1

Millimetres

TOLERANCES:

XX =
 X.X = ±0.2
 X.XX = ±0.10
 X.XXX =
 X° =
 Hole =

rakon

© 2013 Rakon Limited

Drawing Name: XO S Series Test Circuit (Package Z)

CMOS TEST CIRCUIT:

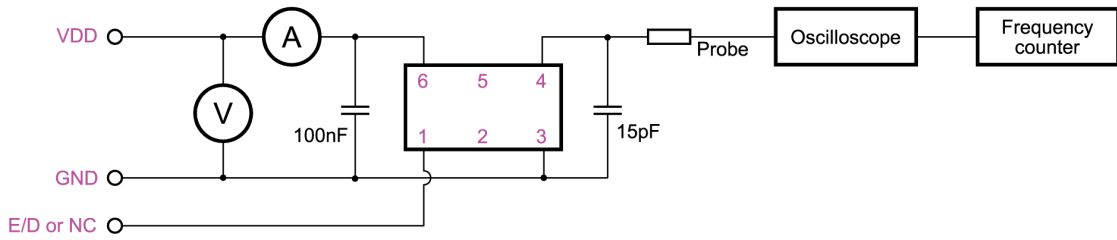

LVPECL TEST CIRCUIT:

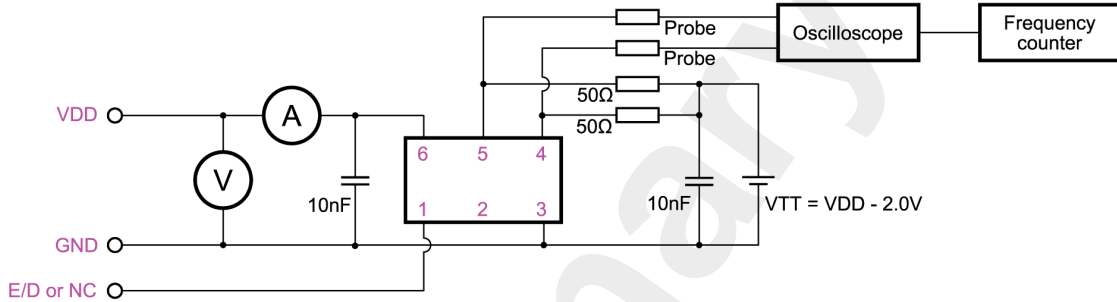

LVDS TEST CIRCUIT:

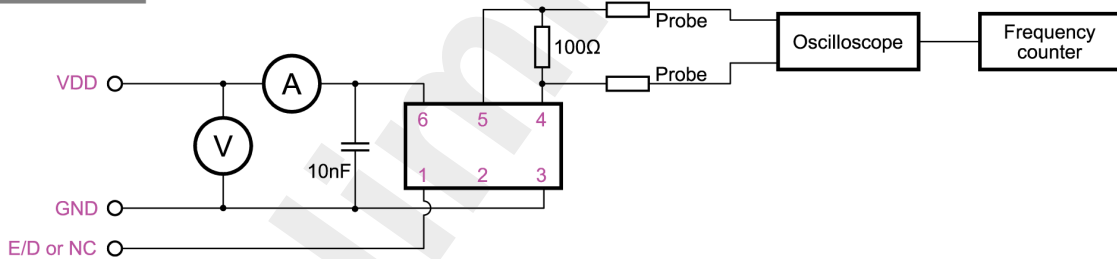

HCSL TEST CIRCUIT:

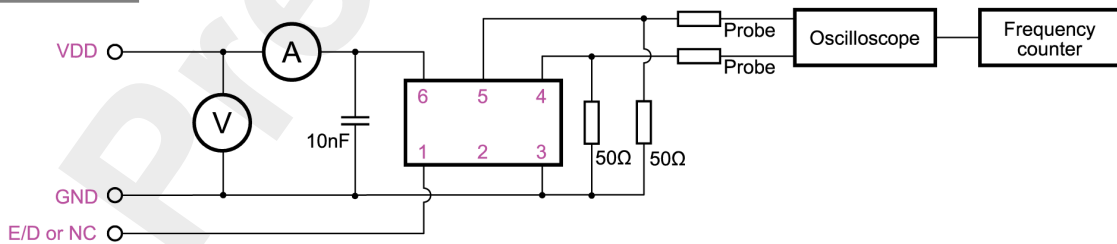

TITLE: XO S SERIES TEST CIRCUIT (Package Z)

FILENAME: CAT723

RELATED DRAWINGS:

REVISION: A

DATE: 08-Oct-12

SCALE: 1 : 1

Millimetres

rakon

© 2009 Rakon Limited

Drawing Name: XO/VCXO 2520 Tape & Reel (Package Z)

TAPE DETAIL (SCALE 2 : 1)

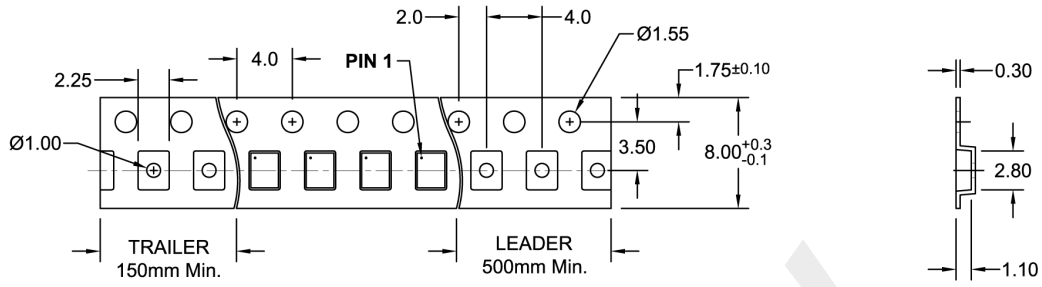

REEL DETAIL (SCALE 1 : 2.5)

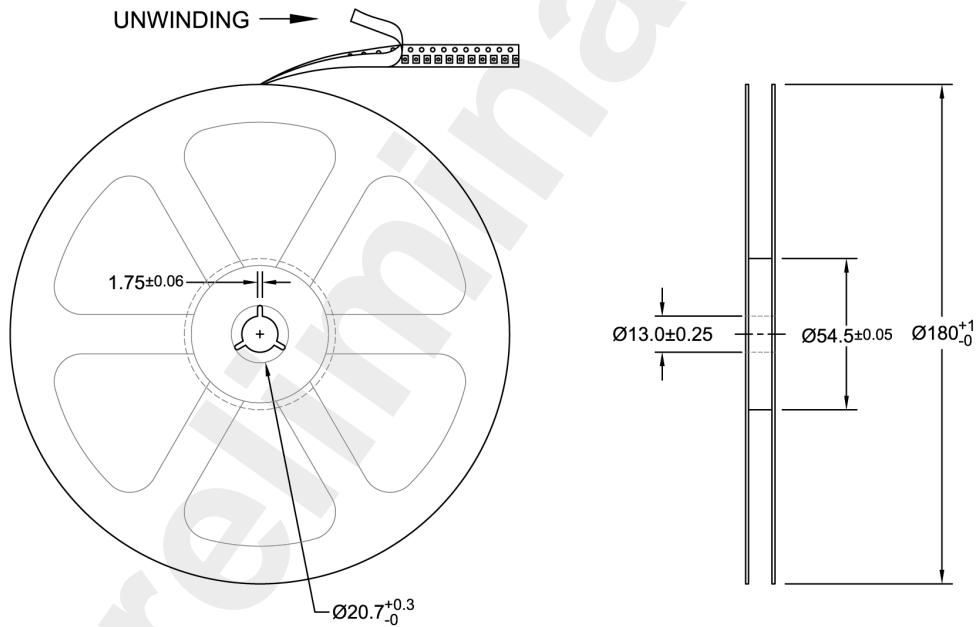

TITLE: XO/VCXO 2520 TAPE & REEL (Package Z)

RELATED DRAWINGS:

FILENAME: CAT731

REVISION: A

DATE: 09-Oct-12

SCALE: 2 : 1

Millimetres

TOLERANCES:

XX = ±0.5

X.X = ±0.2

X.XX = ±0.10

X.XXX = ±0.05

X° =

Hole =

rakon

© 2009 Rakon Limited

Drawing Name: Pb-Free Reflow

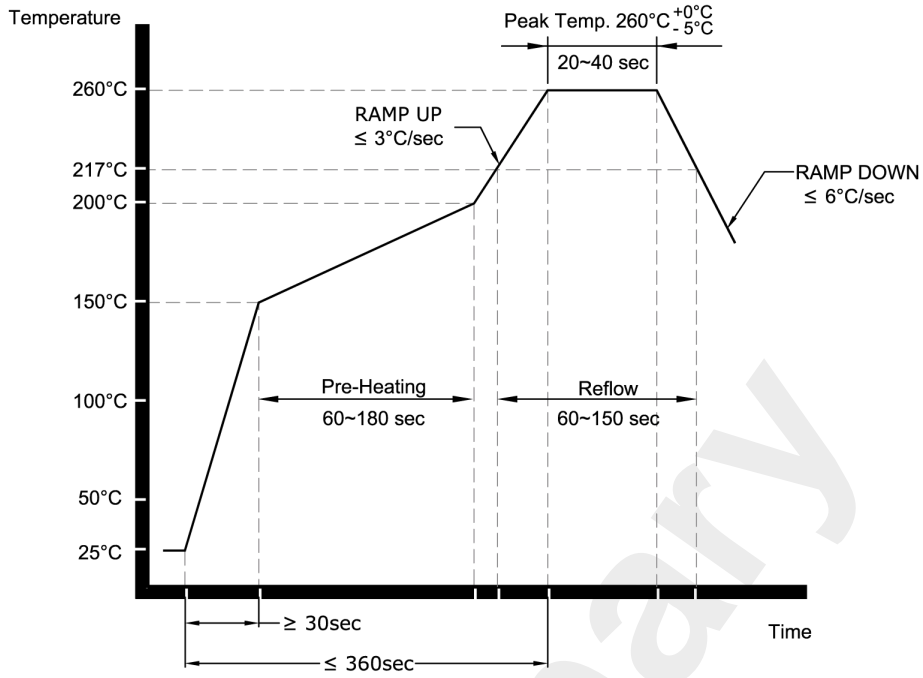

NOTE:

The product has been tested to withstand the Reflow Profile shown. The Reflow Profile used to solder Rakon products is determined by the solder paste Manufacturer's specification. It is recommended that the Reflow Profile used does not exceed the one shown above.

TITLE: Pb-FREE REFLOW

RELATED DRAWINGS:

FILENAME: CAT541

REVISION: B

DATE: 05-Sep-11

SCALE: NTS

Millimetres

rakon

© 2009 Rakon Limited