



# FC7630 SP FIXED- MULTI-OUTPUT REGULATORS

## DESCRIPTION

The FC7630 is a multi-output positive voltage regulator designed to provide fixed precision output voltages of 5.1V, 8V at current up to 0.5A and 12V at current up to 1A with external PNP transistor. An internal reset circuit generates a reset pulse when the output 1 decrease below the regulated value. Output2 & 3 can be disabled by TTL input. Protection features include over voltage protection, short circuit protection and thermal shutdown.

## FEATURES

- Output Currents up to 0.5A (output1 & 2)
- Output Current up to 1A with External Transistor (output3)
- Fixed Precision Output 1 voltage 5.1V  $\pm 2\%$
- Fixed Precision Output 2 voltage 8V  $\pm 2\%$
- Control Signal Generator for Output 3 voltage (12V  $\pm 2\%$ )
- Reset Facility for Output Voltage1
- Output 2,3 with Disable by TTL Input
- Current Limit Protection at Each Output
- Thermal Shut Down

10-SIP H / S



$T_A = 0 \dots +125^\circ\text{C}$

## Internal Block Diagram

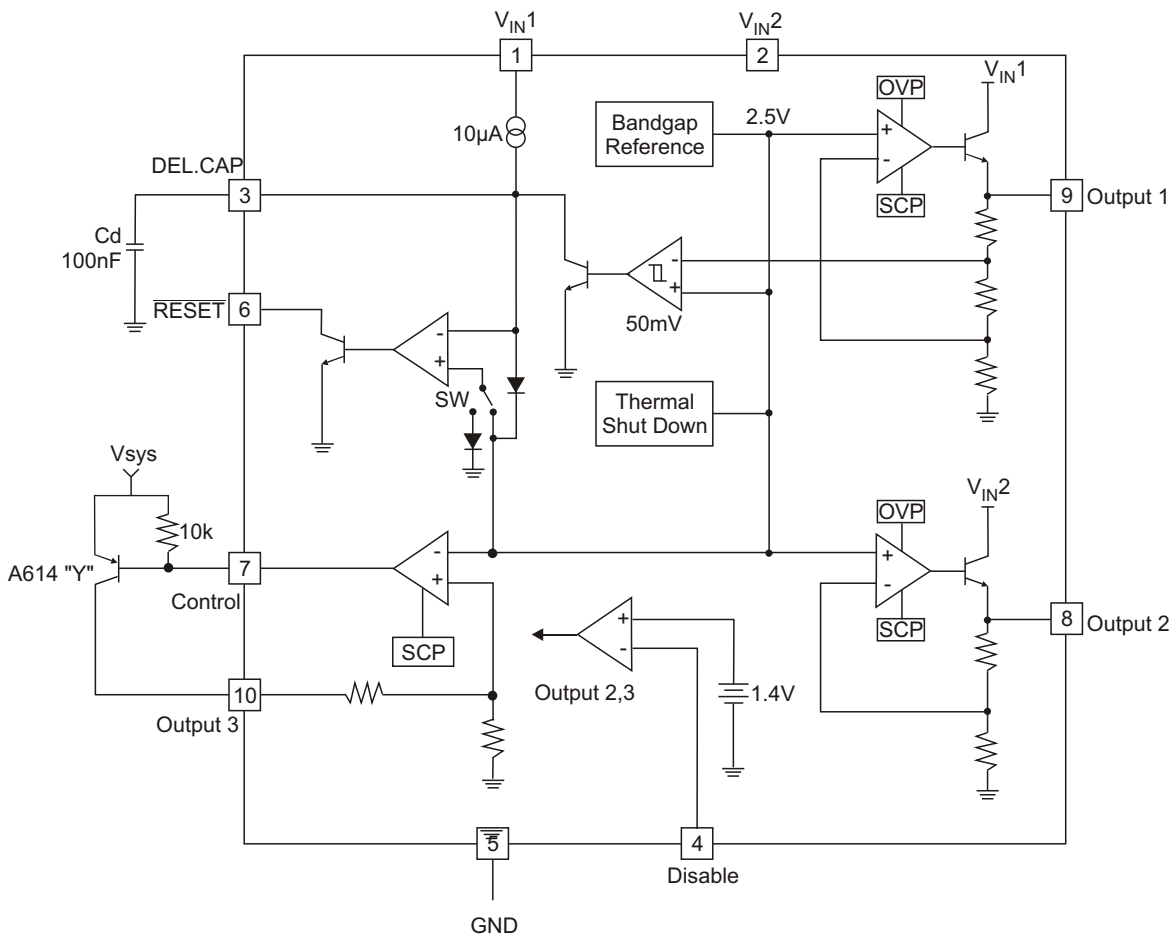



# FC7630 SP FIXED- MULTI-OUTPUT REGULATORS

## ◆ ABSOLUTE MAXIMUM RATINGS

PARAMETER	SYMBOL	RATINGS	UNITS	REMARK
DC Input Voltage	$V_{IN}$	20	V	-
Disable Input Voltage	$V_C$	20	V	-
Output Current	$I_O$	0.5	A	-
Power Dissipation	$P_D$	1.5	W	No Heatsink
Junction Temperature	$T_J$	+150	°C	-
Operating Temperature	$T_{opr}$	0 ~ +125	°C	-

## ◆ ELECTRICAL CHARACTERISTICS

(Refer to test circuit  $V_{IN1}=7.5V$ ,  $V_{IN2}=10.5V$ ,  $T_J=25^\circ C$ , unless otherwise specified)

Parameter	Symbol	Condition	Min	Typ	Max	Unit
Output Voltage 1	$V_{O1}$	$I_{O1}=10mA$ , $7.5V < V_{IN1} < 14V$ $5mA < I_{O1} < 500mA$	5.0 4.9	5.1 5.1	5.2 5.3	V
Output Voltage 2	$V_{O2}$	$I_{O2}=10mA$ , $10.5V < V_{IN2} < 18V$ $5mA < I_{O2} < 500mA$	7.84 7.7	8 8	8.16 8.3	V
Dropout Output Voltage 1,2	$V_{d1,2}$	$I_{O1,2}=500mA$ ,	-	-	2.5	V
Line Regulation 1,2	$V_{O1,2}$	$7.5V < V_{IN1} < 14V$ $10.5V < V_{IN2} < 18V$ $I_{O1,2}=200mA$	-	-	50 80	mV
Load Regulation 1, 2	$V_{O1,2}$	$5mA < I_{O1} < 500mA$ $5mA < I_{O2} < 500mA$	-	0.1	100 160	mV
Output Voltage 3	$V_{O3}$	$V_{sys}=13V$ , $I_{O3}=100mA$	11.7	12	12.3	V
Line Regulation 3	$V_{O3}$	$13V < V_{IN3} < 18V$ $I_{O3}=100mA$	-	-	120	mV
Load Regulation 3	$V_{O3}$	$5mA < I_{O3} < 1A$	-	-	250	mV
Reset Pulse Delay	Trd	$C_d=100nF$ , Note 1	-	25	-	ms
Saturation Voltage in Reset Condition	VrL	$I_6=5mA$	-	-	0.4	V
Leakage Current Pin 6	IrH	$V_6=10V$	-	-	10	$\mu A$
Output Voltage Thermal Drift	STt	$0^\circ C < T_J < +125^\circ C$ , Note 2	-	100	-	ppm/°C
Short Circuit Output Current	Isc 1,2	$V_{IN1}=7.5V$ , $V_{IN2}=10.5V$	-	-	1.6	A
Disable Voltage High	VdisH	Output 2 Active	2.0	-	-	V
Disable Voltage Low	VdisL	Output 2 Disabled	-	-	0.8	V
Disable Bias Current	Idis	$0V < V_{dis} < 7V$	-100	-	2	$\mu A$
Junction Temperature for TSD	Ttsd	Note 2	-	145	-	°C
Quiescent Current	Iq	$I_{O1}=10mA$ , Output2 Disabled	-	-	2	mA
Reset Threshold Voltage	Vr	$K=V_{O1}$	K -0.4	K -0.25	K -0.1	V
Reset Threshold Hysteresis	Vrth	Note 1	20	50	100	mA

### Notes:

1. To check the reset circuit, the reset output is low to discharge the delay capacitor(=Cd). if it's less than  $V_{O1}-0.25V$ . And the reset output is high when the delay capacitor voltage linearly increased by the internal current source(10 $\mu A$ ) if it's more than  $V_{O1}-0.2V$ . The equations of delay time is same as below.  $Trd = (Cd \times 2.5) / 10\mu A$

2. These parameters, although guaranteed, are not 100% tested in production.



# FC7630 SP FIXED- MULTI-OUTPUT REGULATORS

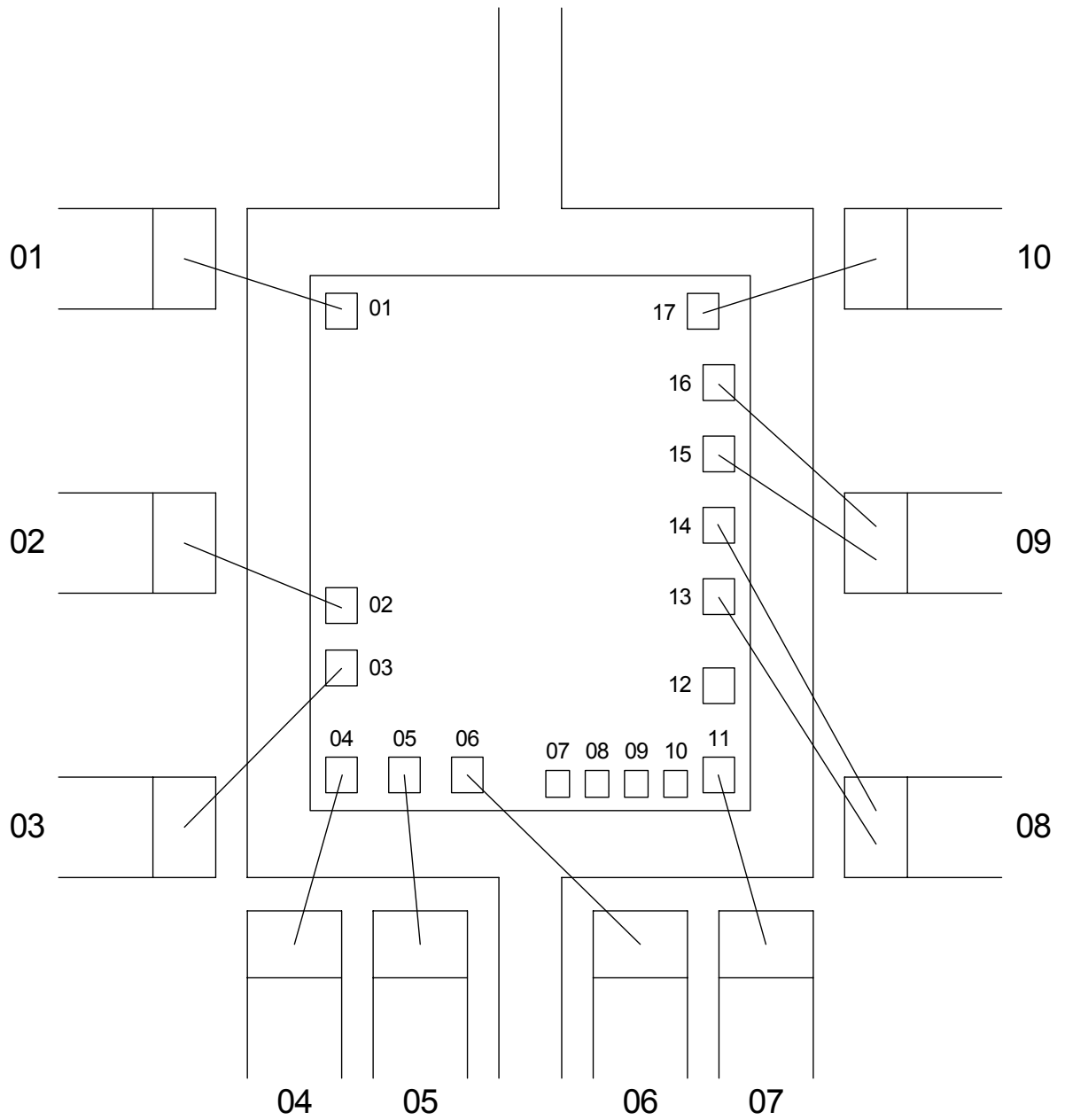

**Bonding diagram of FC7630**



# FC7630 SP FIXED- MULTI-OUTPUT REGULATORS

## TYPICAL APPLICATION

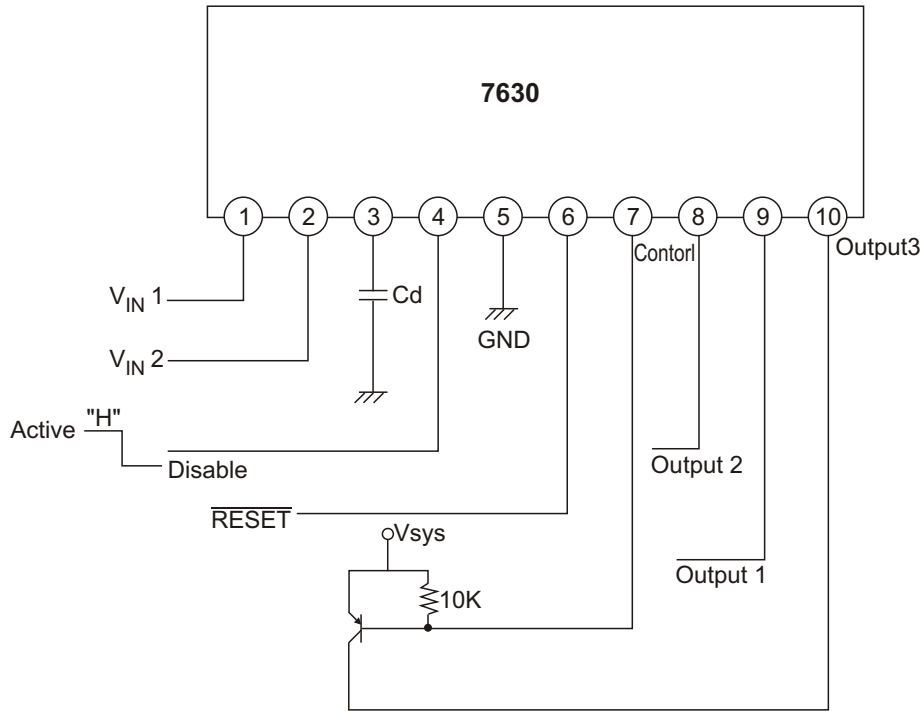

## ◆ 10-SIP H/ S PACKAGE OUTLINE DIMENSIONS

