



MAP7103

3A, High Voltage Boost Converter

MAP7103 – 3A, High Voltage Boost Converter

General Description

The MAP7103 is a high performance switching boost converter that provides a regulated supply voltage for active matrix thin film transistor(TFT) liquid crystal displays(LCDs)

The MAP7103 incorporates current mode, fixed-frequency, pulse width modulation(PWM) circuit with a build in N-MOSFET to achieve high efficiency and fast transient response.

The MAP7103 is available in a TDFN-10L 3x3mm² package

Features

- 4.5A, 0.1Ω, 45V Power MOSFET
- 8.6V to 15.9V Input Supply Voltage
- Fixed 500kHz Switching Frequency
- Input Supply Under Voltage Lockout
- Programmable Soft-Start
- VOUT Over Voltage Protection
- Over Temperature Protection
- Internal Current Limit
- Thin 10-Lead TDFN Package
- RoHS Compliant and Halogen Free

Application

- GIP TFT-LCD Panels

Ordering Information

Part Number	Top Marking	Ambient Temperature Range	Package	RoHS Status
MAP7103DFRH	MAP7103 LLLL YWXZ	-40°C to +85°C	3mm x 3mm TDFN 10Lead	Halogen Free

Block Diagram

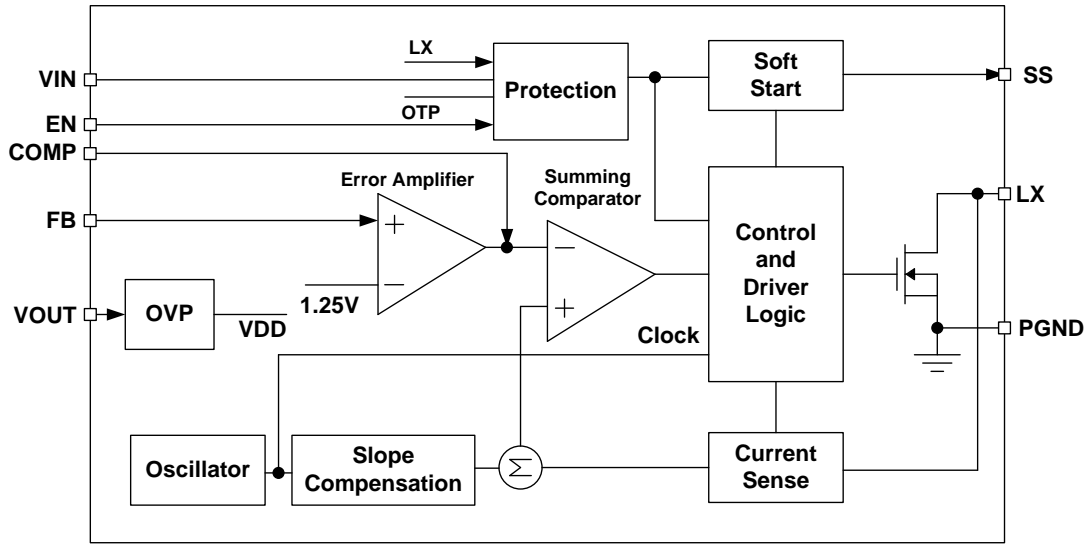
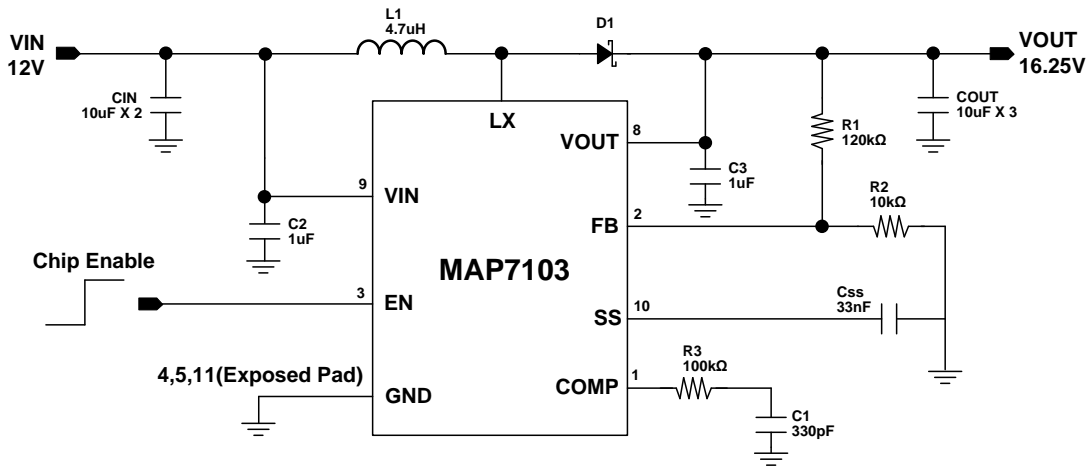

Figure 1) Block Diagram

Typical Application Circuit



Bill of Materials

item	Part Number	Manufacturer	Description	Qty.
IC	MAP7103	Magnachip	3A, 16V Step-Up Converter	1
L1	RLF7030-4R7M	TDK	4.7uH, 3.5A, 26mΩ, ±20%	1
D1	B530C	Diodes	30V, 5A, SMC	1
C _{IN}	CL21A106KAFN3NE	Samsung	10uF, 25V, 2012, X5R	2
C _{OUT}	CL21A106KAFNNNE	Samsung	10uF, 25V, 2012, X5R	3
C ₁	CL10B331KB8NNNC	Samsung	330pF, 50V, 1608, X5R	1
C ₂ /C ₃	CL10A105KA8NNNC	Samsung	1uF, 25V, 1606, X5R	2
C _{SS}	CL10B333JB8NNNC	Samsung	33nF, 50V, 1608, X5R	1
R ₁	RC1608J124CS	Samsung	120kΩ, 1/10W, ±5%	1
R ₂	RC1608J103CS	Samsung	10kΩ, 1/10W, ±5%	1
R ₃	RC1608J104CS	Samsung	100kΩ, 1/10W, ±5%	1

Pin Configuration

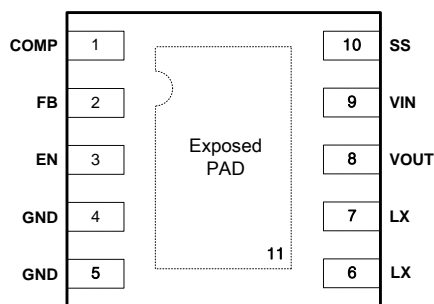

3mm x 3mm Ultra thin DFN-10
(Top view)

Pin Definitions

Pin#	Name	Description
1	COMP	Compensation Pin for Error Amplifier. Connect a series RC from COMP to GND.
2	FB	Feedback. The FB regulation voltage is 1.25V nominal. Connect an external resistive voltage divider between the step-up regulator's output(VOUT) and GND, with the center tap connected to FB. Place the divider close to the IC and minimize the trace area to reduce noise coupling.
3	EN	Chip Enable. Drive EN low to turn off the Boost
4,5,11 (Exposed Pad)	GND	Ground. The Exposed Pad must be soldered to a large PCB and connected to GND for maximum power dissipation.
6,7	LX	Switch. LX is the drain of the internal MOSFET. Connect the inductor/rectifier diode junction to LX and minimize the trace area for lower EMI.
8	VOUT	Boost Converter Over Voltage Protection input. Bypass VOUT with a minimum 1uF ceramic capacitor directly to GND.
9	VIN	Supply Input. Bypass VIN with a minimum 1uF ceramic capacitor directly to GND.
10	SS	Soft-Start Control. Connect a soft-start capacitor(C _{SS}) to this pin. The soft-start capacitor is charged with a constant current of 5uA. The soft-start capacitor is discharged to ground when EN is low

Absolute Maximum Ratings

Parameter	Value	Unit
LX, VOUT to GND	-0.3V to 28V	V
VIN, EN, SS, FB to GND	-0.3V to 16.5V	V
COMP to GND	-0.3V to 6.0V	V
Junction Temperature Range	-40 to +150	°C
Storage Temperature Range	-65 to +150	°C
Package Thermal Resistance (JA)	65.9	°C/W
Power Dissipation (Ta=25°C)	1.517	W
Human Body Model(HBM)	2	kV
Machine Model(MM)	200	V
Charged Device Model (CDM)	700	V

Note:

Absolute Maximum Ratings are those values beyond which damage to the device may occur. Functional operation under these conditions is not implied.

Recommended Operating conditions

Ambient Temperature Range	-40 to +85	°C
Junction Temperature Range	-40 to +125	°C

Electrical Characteristics

$V_{IN}=V_{EN}=12V$, $V_{OUT}=16.25V$, Typical values are at $T_A=25^\circ C$ (unless otherwise noted.)

Symbol	Parameter	Test Conditions	Min.	Typ.	Max.	Unit
General Section						
V_{IN}	Input Voltage Range		8.6		15.9	V
V_{UVLO}	Under Voltage Lock Out	Rising Threshold voltage	8.0	8.3	8.6	V
		Hysteresis	0.6	0.8	1.0	V
$I_{Q(ON)}$	Quiescent Current	VFB=1.3V, Not Switching		1.0	1.2	mA
R_{EN}	Enable Pull down resistance		0.5	1.0	1.5	M Ω
T_{SD}	Thermal Shutdown Temperature	(Note1)		150		$^\circ C$
T_{SD_HYS}	Thermal Shutdown Hysteresis	(Note1)		10		$^\circ C$
V_{OVP}	V_{OUT} Over Voltage Threshold	V_{OUT} Rising	18	19	20	V
Oscillator						
f_{OSC}	Oscillator Frequency		450	500	550	kHz
D_{MAX}	Maximum Duty Cycle		81	90	99	%
Error Amplifier						
V_{REF}	FB Regulation Voltage		1.2375	1.25	1.2625	V
I_{FB}	FB Input Bias Current				100	nA
V_{FB_LINE}	FB Line Regulation			0.05	0.2	V
G_m	Transconductance	$\Delta I = \pm 2.5\mu A$ at $V_{COMP}=1V$	80	100	120	$\mu A/V$
AV	Voltage Gain (Note1)	FB to COMP		700		V/V
N-MOSFET						
I_{LIM}	Current Limit	(Note1)	4.5			A
$R_{DS(ON)}$	On-Resistance	(Note1)		100	250	m Ω
I_{LEAK}	Leakage Current	VLX=24V			10	μA
RCS	Current Sense Transresistance	(Note1)		0.25		V/A
Soft-Start						
	Charge Current		3.5	5.0	6.5	μA
Control Inputs						
V_{IH}	Enable Logic High Voltage		1.4			V
V_{IL}	Enable Logic Low Voltage				0.7	

Note1) Guaranteed by design, characterization and correlation with process controls, Not fully tested in production

TYPICAL CHARACTERISTICS

Quiescent Current vs. Temperature

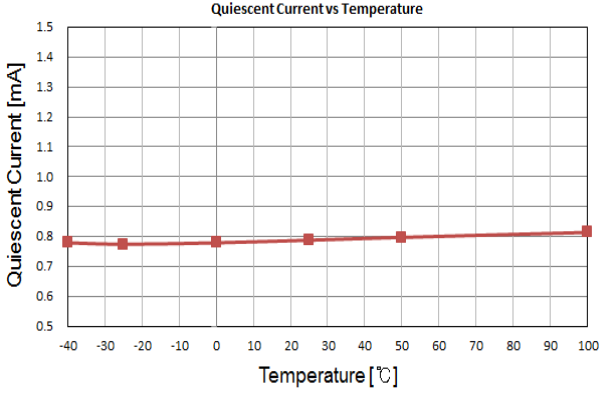

Figure 1. Quiescent Current

FB Leakage Current vs. Temperature

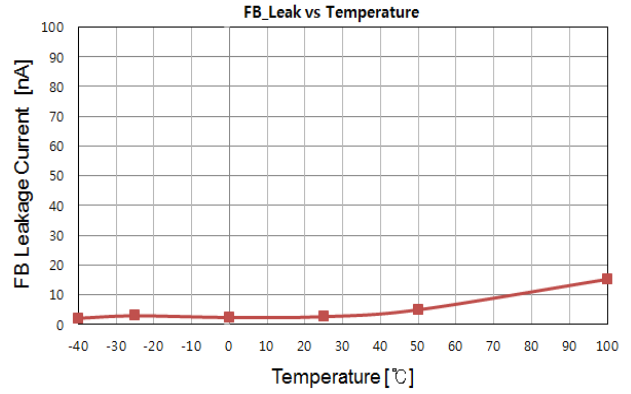

Figure 2. Feedback leakage Current

Boost Frequency vs. Temperature

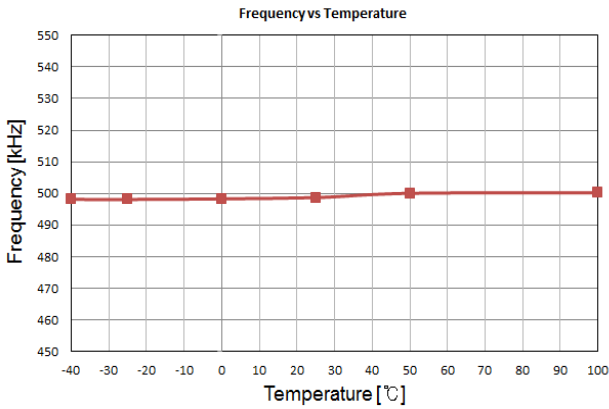

Figure 3. Boost Frequency

Boost Frequency vs. Temperature

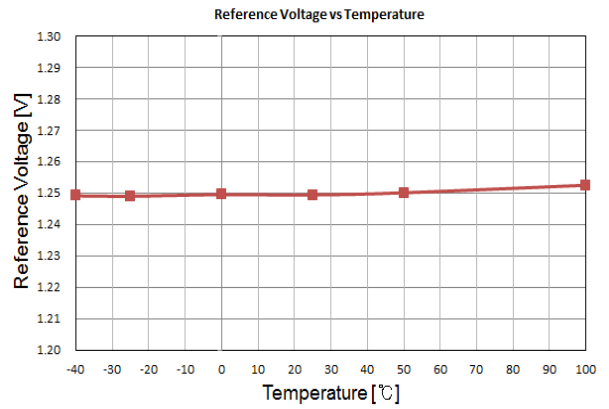

Figure 4. Efficiency – Inductor [4.7uH]

Switching Waveform [Light Load]

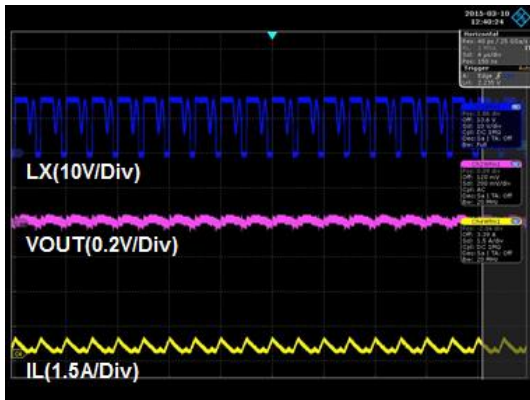

Figure 5. Output Voltage – Light Load(0.1A)

Switching Waveform [Heavy Load]

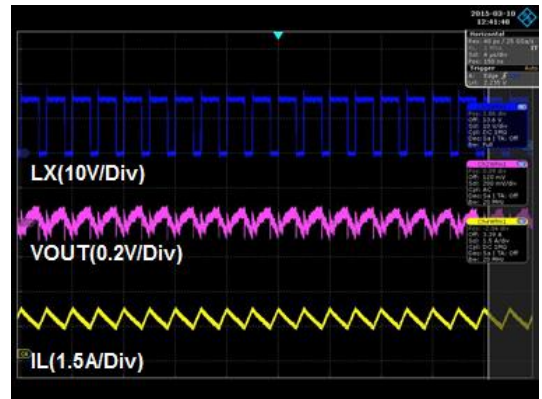

Figure 6. Output Voltage – Heavy Load(1.0A)

Operation

The MAP7103 provides a regulated supply voltage for panel source driver ICs. The MAP7103 uses a constant frequency, peak current mode PWM(Pulse Width Modulation) boost regulation architecture to regulate the feedback voltage.

At the beginning of each cycle, the N-channel MOSFET switch is turned on, forcing the inductor current to rise. The current at the source of the switch is internally measured and converted to a voltage by the current sense amplifier. That voltage is compared to the error voltage at COMP. The voltage at the output of the error amplifier is an amplified version of the difference between the 1.25V reference voltage and the feedback voltage. When these two voltage are equal, the PWM comparator turns off the switch forcing the inductor current to the output capacitor through the external rectifier. This causes the inductor current to decrease. The peak inductor current is controlled by the voltage at COMP, which in turn is controlled by the output voltage. Thus the output voltage is regulated by the inductor current to satisfy the load. The use of current mode regulation improves transient response and control loop stability.

Application Information

Soft-Start Capacitor

The MAP7103 provides soft-start function to minimize the inrush current at the input. This prevents faults tripping of the input voltage at startup due to input current overshoot. When powered on, a 5uA internal constant current charges an external capacitor at SS pin. As the SS capacitor is charged, the voltage at SS rises. The MAP7103 internally clamps the voltage at COMP to 700mV above the voltage at SS. The soft-start ends when the voltage at SS reaches 1.25V. This limits the inductor current at startup, forcing the input current to rise slowly to the current required to regulate the output voltage.

The soft-start period is determined by the equation :

$$t_{SS} = C_{SS} \times V / I$$

where C_{SS} is the soft-start capacitor from SS to GND, V is reference voltage and I is charging current. If $C_{SS}=33nF$, the internal soft-start function will be turned on and period time is approximately 8ms.

Setting the Output Voltage

The regulated output voltage is shown as the following equation

$$V_{OUT} \approx V_{REF} \times \left(1 + \frac{R_1}{R_2}\right) \quad \text{where } V_{REF}=1.25V \text{ (typ.)}$$

The recommended voltage for R2 should be at least 10kΩ

Selecting the input Capacitor

Lower ESR ceramic capacitor are recommended for input capacitor applications. Low ESR will reduce the input voltage ripple caused by switching operation. A 10uF capacitor is sufficient for most applications.

Selecting the Output Capacitor

The output capacitor is required to maintain the DC output voltage. Low ESR capacitor are preferred to keep the output voltage ripple to a minimum. The characteristic of the output capacitor also affects the stability of the regulation control system. The output voltage ripple is shown as the following equation:

$$V_{RIPPLE} \approx \frac{\left(1 - \frac{V_{IN}}{V_{OUT}}\right) \times I_{LOAD}}{C_{OUT} \times f_{SW}}$$

where V_{RIPPLE} is the output ripple voltage, V_{IN} and V_{OUT} are the DC Input and output voltages respectively, I_{LOAD} is the load current, f_{SW} is the switching frequency, and C_{OUT} is the capacitance of the output capacitor

Choose an output capacitor to satisfy the output ripple and load transient requirements of the design. A 4.7uF – 22uF ceramic capacitor is suitable for most applications

Loop Compensation

The output of the transconductance error amplifier (COMP) is used to compensate the regulation control system. The system uses two poles and one zero to stabilize the control loop. The poles are f_{p1} set by the output capacitor C_{OUT} and load resistance and f_{p2} set by the compensation capacitor C1. The zero f_{z1} is set by the compensation capacitor C1 and the compensation resistor R3. For typical application, $V_{IN}=12V$, $V_{OUT}=16.25V$, $C_{OUT}=10\mu F \times 3EA$, $L1=4.7\mu H$, while the recommended value for compensation is as follows : $R3 = 100k\Omega$, $C1=330pF$

Selecting the Inductor

The inductor is required to force the higher output voltage while being driven by the input voltage. A larger value inductor results in less ripple current that results in lower peak inductor current, reducing stress on the internal N-channel switch. However, the larger series resistance, and/or lower saturation current. A 4.7uF Inductor is recommended for most 500kHz applications. As a general rule, the peak-to-peak ripple current range is 20% to 40% of the maximum input current. Make sure that the peak inductor current is below 75% of the current limit at the operating duty cycle to prevent loss of regulation due to the current limit. Also make sure that the inductor does not saturate under the worst-case load transient and startup conditions. Calculate the required inductance value by the equation

$$L \approx \frac{V_{IN} \times (V_{OUT} - V_{IN})}{V_{OUT} \times f_{SW} \times \Delta I}$$

$$I_{IN(MAX)} = \frac{V_{OUT} \times I_{LOAD(MAX)}}{V_{IN} \times \eta}$$

$$\Delta I = (30\% - 50\%) I_{IN(MAX)}$$

Where $I_{LOAD(MAX)}$ is the maximum load current, ΔI is the peak-to-peak inductor ripple current, and η is efficiency

Selecting the Diode

The output rectifier diode supplies current to the inductor when the internal MOSFET is off. Schottky diodes are chosen for their low forward voltage drop and fast switching speed. The diode should be rated for a reverse voltage equal to or greater than the output voltage used. The average current rating must exceed the average output current and the peak current rating must be greater than the peak inductor current.

Package Dimensions

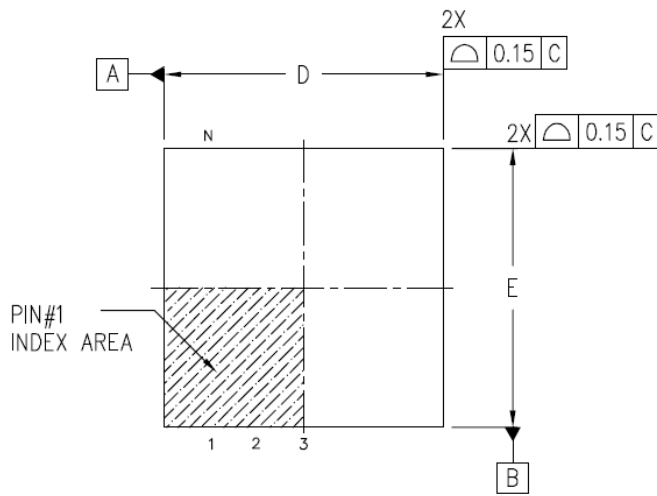

TOP VIEW

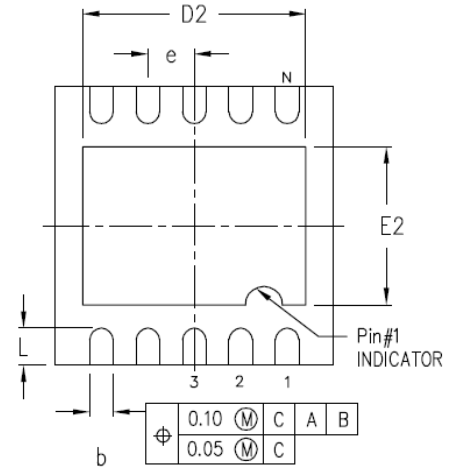

BOTTOM VIEW

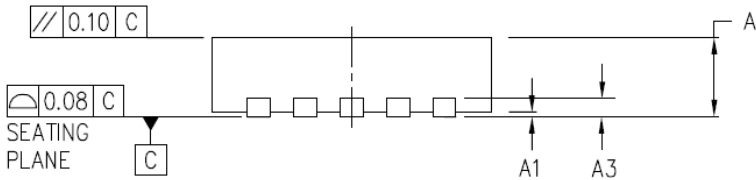

SIDE VIEW

Symbol	Dimnsion (mm)	
	Min	Max
A	0.70	0.80
A1	0.00	0.05
A3	0.20 REF.	
D	2.85	3.15
E	2.85	3.15
D2	2.30	2.50
E2	1.55	1.80
b	0.18	0.30
e	0.50 BSC	
L	0.30	0.50

REVISION HISTORY

Date	Version	Changes
2014.08.11	0.0	Initial Release.
2014.10.09	0.1	Update to Display Spec
2014.10.20	0.2	Update to Package Information
2014.11.07	0.3	VREF Accuracy : 1.5% → 1.0% Enable Pull-down Resistance : 500k Ω → 1M Ω
2014.11.19	0.4	Preliminary Datasheet
2014.12.19	0.5	Operating description (Page 5 ~ 6)
2015.03.04	0.6	Operating Input Voltage Range : 15.5V(Max.) → 15.9V(Max.)
2015.04.19	0.7	Absolute Maximum Ratings : FB,SS (6.0V) → FB, SS (16.5V)
2015.05.27	0.8	Add to graph
2015.06.16	0.9	Change Logic Threshold Voltage level(V_{IH} & V_{IL})
2015.06.30	0.10	Update Package thermal Resistance
2015.07.03	1.00	Update Absolute maximum ratings(Junction Temperature)