

规格书编号

SPEC NO :

# 产品规格书

# SPECIFICATION

CUSTOMER 客户: \_\_\_\_\_

PRODUCT 产品: \_\_\_\_\_ SAW FILTER \_\_\_\_\_

MODEL NO 型号: \_\_\_\_\_ HDF415C SMD-3 \_\_\_\_\_

MARKING 印字: \_\_\_\_\_ HDF493 \_\_\_\_\_

PREPARED 编制: \_\_\_\_\_ CHECKED 审核: \_\_\_\_\_

APPROVED 批准: \_\_\_\_\_ D A T E 日期: \_\_\_\_\_ 2006-5-11 \_\_\_\_\_

客户确认 CUSTOMER RECEIVED:		
审核 CHECKED	批准 APPROVED	日期 DATE

无锡市好达电子有限公司  
Shoulder Electronics Limited



**1. SCOPE**

This specification shall cover the characteristics of SAW filter With F415 used for the page system.

**2. ELECTRICAL SPECIFICATION**

DC Voltage VDC	10V
AC Voltage Vpp	10V50Hz/60Hz
Operation temperature	-20°C to +60°C
Storage temperature	-45°C to +85°C
RF Power Dissipation	0dBm

Electronic Characteristics

2-1. Typical frequency response

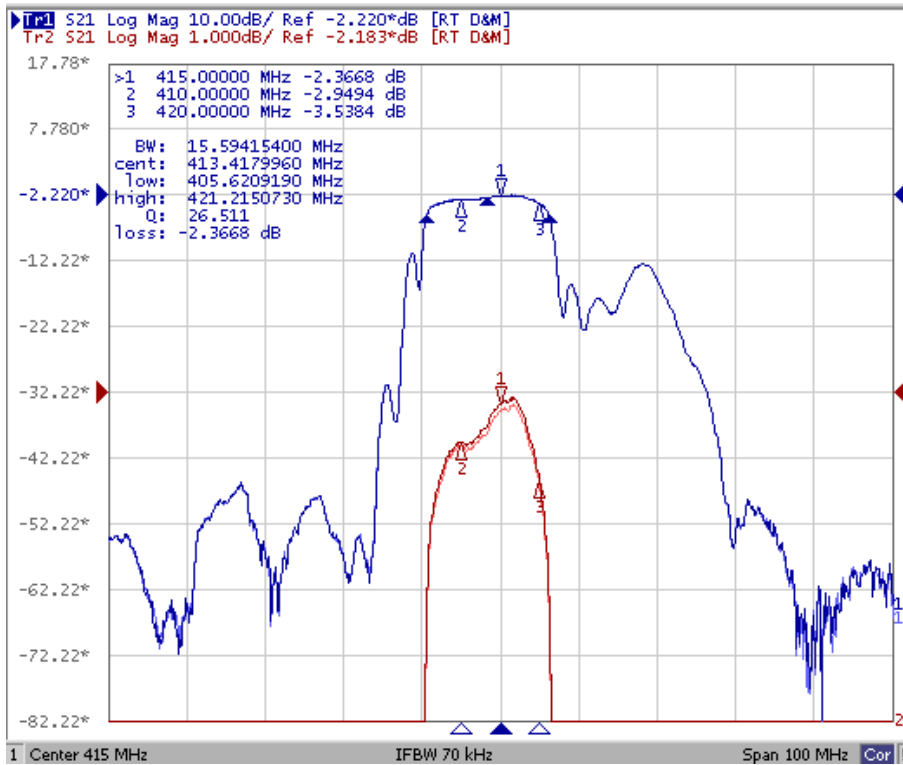

2-2. Electrical characteristics

Part number	F415C	Unit
Nominal center frequency (Fo)	415	MHz
Insertion Loss		dB
1.fo-45.8~fo-39.8 MHz	50min.	
2.fo ± 5.0 MHz	5.0max.	
3.fo +39.8~ fo +45.8MHz	45min.	
Ripple (with Fo ±3.0MHz)	2.0max	dB
Input/Output Impedance(Nominal)	50//0	Ω /pF

### 3. TEST CIRCUIT

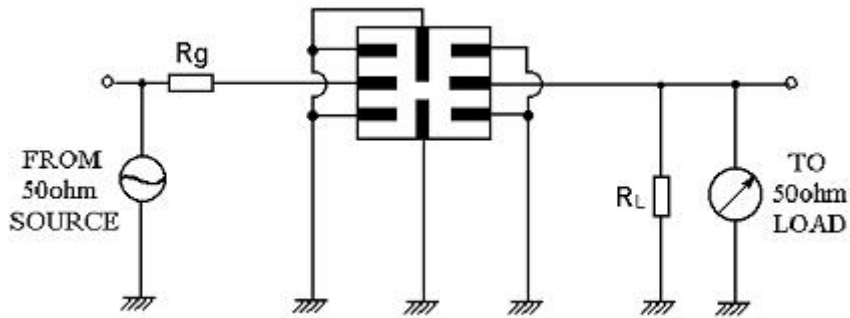

### 4. DIMENSION

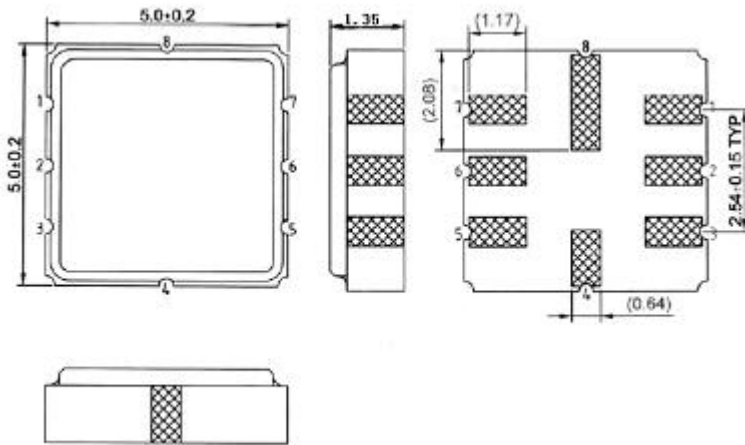

<p><b>2.INPUT</b>  <b>6. OUTPUT</b>  <b>1.3.5.7:GROUND</b>  <b>4.8 GROUND</b></p>
---

### 5. ENVIRONMENTAL CHARACTERISTICS

#### 5-1 Temperature cycling

Subject the device to a low temperature of  $-40^{\circ}\text{C}$  for 30 minutes. Following by a high temperature of  $+25^{\circ}\text{C}$  for 5 Minutes and a higher temperature of  $+85^{\circ}\text{C}$  for 30 Minutes. Then release the device into the room conditions for 1 to 2 hours prior to the measurement. It shall meet the specifications in table 1.

#### 5-2 Resistance to solder heat

Submerge the device terminals into the solder bath at  $260^{\circ}\text{C} \pm 5^{\circ}\text{C}$  for  $10 \pm 1$  sec. Then release the device into the room conditions for 4 hours. It shall meet the specifications in table 1.

#### 5-3 Solderability

Submerge the device terminals into the solder bath at  $245^{\circ}\text{C} \pm 5^{\circ}\text{C}$  for 5s, More than 95% area of the soldering pad must be covered with new solder. It shall meet the specifications in table 1.

#### 5-4 Mechanical shock

Drop the device randomly onto the concrete floor from the height of 1 m 3 times. the filter shall fulfill the specifications in table 1.

#### 5-5 Vibration

Subject the device to the vibration for 2 hour each in x,y and z axes with the amplitude of 1.5 mm at 10 to 55 hz. The filter shall fulfill the specifications in table 1.

## 6. REMARK

### 6.1 Static voltage

Static voltage between signal load & ground may cause deterioration & destruction of the component. Please avoid static voltage.

### 6.2 Ultrasonic cleaning

Ultrasonic vibration may cause deterioration & destruction of the component. Please avoid ultrasonic cleaning

### 6.3 Soldering

Only leads of component may be soldered. Please avoid soldering another part of component.

## 7. Packing

### 7.1 Dimensions

(1) Carrier Tape: Figure 1

(2) Reel: Figure 2

(3) The product shall be packed properly not to be damaged during transportation and storage.

### 7.2 Reeling Quantity

1000 pcs/reel 7"

3000 pcs/reel 13"

### 7.3 Taping Structure

(1) The tape shall be wound around the reel in the direction shown below.

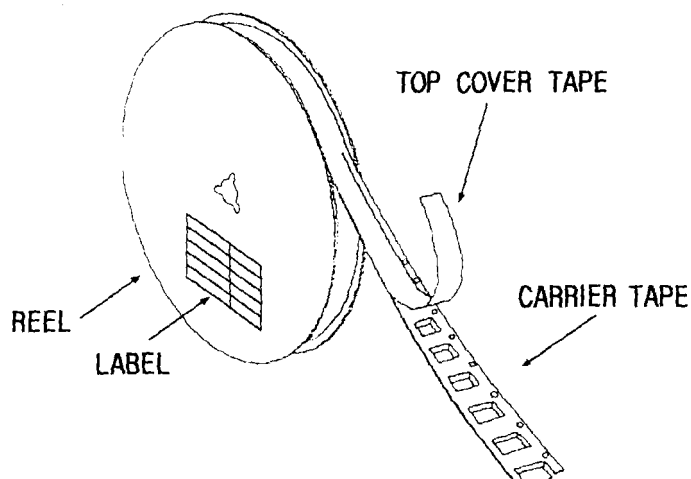

(2) Label

Device Name	
User Product Name	
Quantity	
Lot No.	

(3) Leader part and vacant position specifications.

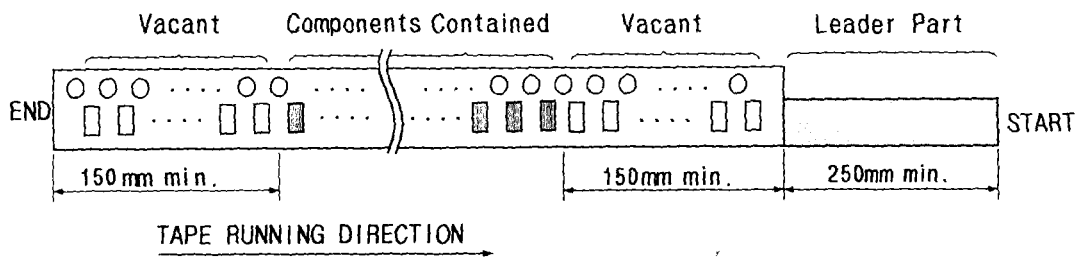

## 8. TAPE SPECIFICATIONS

8.1 Tensile Strength of Carrier Tape: 4.4N/mm width

8.2 Top Cover Tape Adhesion (See the below figure)

- (1) pull off angle: 0~15°
- (2) speed: 300mm/min.
- (3) force: 20~70g

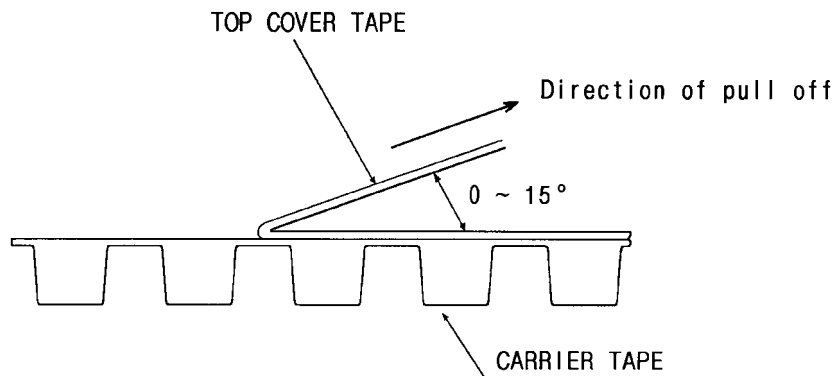

[Figure 1] Carrier Tape Dimensions

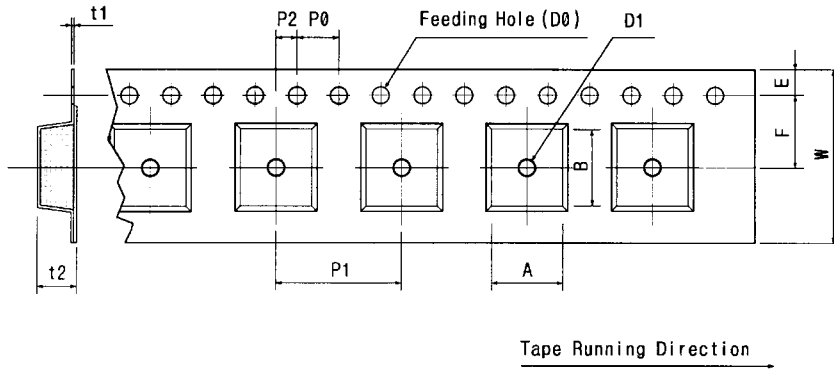

[Unit:mm]

W	F	E	P0	P1	P2	D0	D1	t1	t2	A	B
12.0	5.5	1.75	4.0	8.0	2.0	Ø1.5	Ø1.0	0.3	2.10	6.40	5.20
±0.3	±0.05	±0.1	±0.1	±0.1	±0.05	±0.1	±0.25	±0.05	±0.1	±0.1	±0.1

[Figure 2]

[Unit:mm]

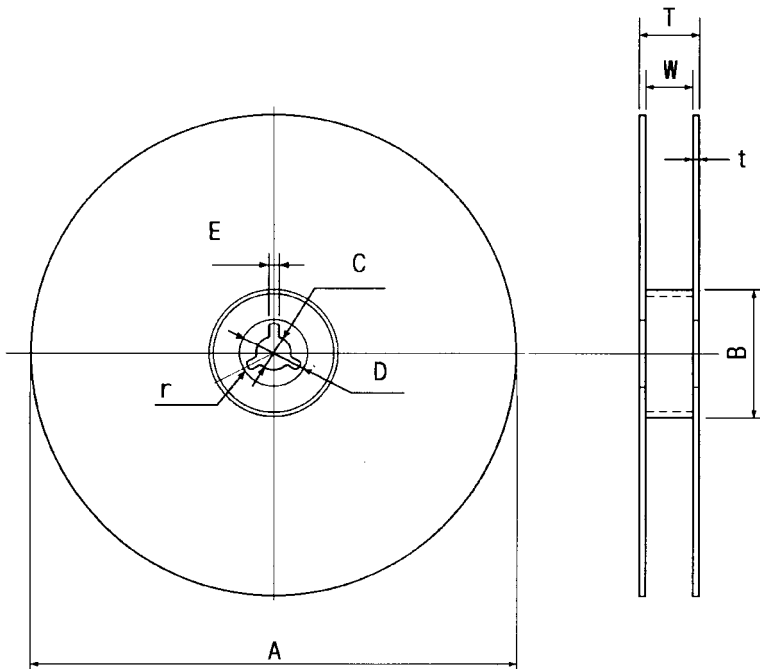

A	B	C	D	E	W	t	r
Ø330	Ø100	Ø13	Ø21	2	13	3	1.0
±1.0	±0.5	±0.5	±0.8	±0.5	±0.3	max.	max.