

4 BIT SINGLE-CHIP MICROCONTROLLER

The μ PD750008 is one of the 75XL series 4-bit single-chip microcontrollers, which provide data processing capability equal to that of an 8-bit microcontroller.

The μ PD750008 is an advanced model of the μ PD75008. It features an enhanced CPU function and enables high-speed operation at a low voltage of 2.2 V. It can be substituted for the μ PD75008. In addition, it is best suited to applications using batteries. The μ PD750008(A) has a higher reliability than the μ PD750008.

A built-in one-time PROM product, μ PD75P0016, is also available. It is suitable for small-scale production and evaluation of application systems.

The following user's manual describes the details of the functions of the μ PD750008. Be sure to read it before designing application systems.

μ PD750008 User's Manual: U10740E

FEATURES

- Capable of low-voltage operation: $V_{DD} = 2.2$ to 5.5 V
- Internal memory
 - Program memory (ROM)
 - : 4096×8 bits (μ PD750004 and μ PD750004(A))
 - : 6144×8 bits (μ PD750006 and μ PD750006(A))
 - : 8192×8 bits (μ PD750008 and μ PD750008(A))
 - Data memory (RAM)
 - : 512×4 bits
- Function for specifying the instruction execution time (useful for high-speed operation and saving power)
 - $0.95 \mu\text{s}$, $1.91 \mu\text{s}$, $3.81 \mu\text{s}$, $15.3 \mu\text{s}$ (when operating at 4.19 MHz)
 - $0.67 \mu\text{s}$, $1.33 \mu\text{s}$, $2.67 \mu\text{s}$, $10.7 \mu\text{s}$ (when operating at 6.0 MHz)
 - $122 \mu\text{s}$ (when operating at 32.768 kHz)
- Enhanced timer function (4 channels)
- Can be easily substituted for the μ PD75008 because this product succeeds to the functions and instructions of the μ PD75008.

APPLICATIONS

- μ PD750004, μ PD750006, and μ PD750008
Cordless telephones, radio devices, audio products, and home electric appliances
- μ PD750004(A), μ PD750006(A), and μ PD750008(A)
Electrical equipment for automobiles

The μ PD750004, μ PD750006, μ PD750008, μ PD750004(A), μ PD750006(A), and μ PD750008(A) differ only in quality grade. In this manual, the μ PD750008 is described unless otherwise specified. Users of other than the μ PD750008 should read μ PD750008 as referring to the pertinent product.

When the description differs among μ PD750004, μ PD750006, and μ PD750008, they also refer to the pertinent (A) products.

μ PD750004 \rightarrow μ PD750004(A), μ PD750006 \rightarrow μ PD750006(A), μ PD750008 \rightarrow μ PD750008(A)

The information in this document is subject to change without notice.

ORDERING INFORMATION

Part number	Package	Quality grade
μPD750004CU-xxx	42-pin plastic shrink DIP (600 mil, 1.778 mm pitch)	Standard
μPD750004GB-xxx-3BS-MTX	44-pin plastic QFP (10 × 10 mm, 0.8 mm pitch)	Standard
μPD750006CU-xxx	42-pin plastic shrink DIP (600 mil, 1.778 mm pitch)	Standard
μPD750006GB-xxx-3BS-MTX	44-pin plastic QFP (10 × 10 mm, 0.8 mm pitch)	Standard
μPD750008CU-xxx	42-pin plastic shrink DIP (600 mil, 1.778 mm pitch)	Standard
μPD750008GB-xxx-3BS-MTX	44-pin plastic QFP (10 × 10 mm, 0.8 mm pitch)	Standard
μPD750004CU(A)-xxx	42-pin plastic shrink DIP (600 mil, 1.778 mm pitch)	Special
μPD750004GB(A)-xxx-3BS-MTX	44-pin plastic QFP (10 × 10 mm, 0.8 mm pitch)	Special
μPD750006CU(A)-xxx	42-pin plastic shrink DIP (600 mil, 1.778 mm pitch)	Special
μPD750006GB(A)-xxx-3BS-MTX	44-pin plastic QFP (10 × 10 mm, 0.8 mm pitch)	Special
μPD750008CU(A)-xxx	42-pin plastic shrink DIP (600 mil, 1.778 mm pitch)	Special
μPD750008GB(A)-xxx-3BS-MTX	44-pin plastic QFP (10 × 10 mm, 0.8 mm pitch)	Special

Remark xxx is a mask ROM code number.

Please refer to "Quality Grades on NEC Semiconductor Devices" (Document No. C11531E) published by NEC Corporation to know the specification of quality grade on the devices and its recommended applications.

DIFFERENCES BETWEEN μPD75000x AND μPD75000x(A)

Product number / Item	μPD750004	μPD750004(A)
	μPD750006	μPD750006(A)
	μPD750008	μPD750008(A)
Quality grade	Standard	Special

FUNCTIONS

Item		Function	
Command execution time		<ul style="list-style-type: none"> • 0.95, 1.91, 3.81, 15.3 μs (when the main system clock operates at 4.19 MHz) • 0.67, 1.33, 2.67, 10.7 μs (when the main system clock operates at 6.0 MHz) • 122 μs (when the subsystem clock operates at 32.768 kHz) 	
Internal memory	ROM	4096 × 8 bits (μPD750004)	
		6144 × 8 bits (μPD750006)	
		8192 × 8 bits (μPD750008)	
	RAM	512 × 4 bits	
General-purpose register		<ul style="list-style-type: none"> • When operating in 4 bits: 8 × 4 banks • When operating in 8 bits: 4 × 4 banks 	
I/O port	CMOS input	8	Can incorporate 7 pull-up resistors that are specified with the software.
	CMOS I/O	18	Can directly drive the LED. Can incorporate 18 pull-up resistors that are specified with the software.
	N-ch open drain I/O	8	Can directly drive the LED. Can withstand 13 V. Can incorporate pull-up resistors that are specified with the mask option.
	Total	34	
Timer		4 channels <ul style="list-style-type: none"> • 8-bit timer/event counter: 1 channel • 8-bit timer counter: 1 channel • Basic interval timer/watchdog timer: 1 channel • lock timer: 1 channel 	
Serial interface		<ul style="list-style-type: none"> • Three-wire serial I/O mode ... switchable between the start LSB and the start MSB • Two-wire serial I/O mode • SBI mode 	
Bit sequential buffer (BSB)		16 bits	
Clock output (PCL)		<ul style="list-style-type: none"> • Φ, 524 kHz, 262 kHz, 65.5 kHz (when the main system clock operates at 4.19 MHz) • Φ, 750 kHz, 375 kHz, 93.8 kHz (when the main system clock operates at 6.0 MHz) 	
Buzzer output (BUZ)		<ul style="list-style-type: none"> • 2 kHz, 4 kHz, 32 kHz (when the main system clock operates at 4.19 MHz or when the subsystem clock operates at 32.768 kHz) • 2.93 kHz, 5.86 kHz, 46.9 kHz (when the main system clock operates at 6.0 MHz) 	
Vectored interrupt		External : 3 Internal : 4	
Test input		External : 1 Internal : 1	
System clock oscillator		<ul style="list-style-type: none"> • Ceramic or crystal oscillator for main system clock • Crystal oscillator for subsystem clock 	
Standby		STOP/HALT mode	
Operating ambient temperature range		T _A = -40 to +85 °C	
Supply voltage		V _{DD} = 2.2 to 5.5 V	
Package		42-pin plastic shrink DIP (600 mil, 1.778 mm pitch) 44-pin plastic QFP (10 × 10 mm, 0.8 mm pitch)	

CONTENTS

1. PIN CONFIGURATION (TOP VIEW)	6
2. BLOCK DIAGRAM	8
3. PIN FUNCTIONS	9
3.1 PORT PINS	9
3.2 NON-PORT PINS	10
3.3 PIN INPUT/OUTPUT CIRCUITS	11
3.4 CONNECTION OF UNUSED PINS	13
4. Mk I MODE/Mk II MODE SWITCH FUNCTION	14
4.1 DIFFERENCES BETWEEN Mk I MODE AND Mk II MODE	14
4.2 SETTING OF THE STACK BANK SELECTION REGISTER (SBS)	15
5. MEMORY CONFIGURATION	16
6. PERIPHERAL HARDWARE FUNCTIONS	21
6.1 DIGITAL I/O PORTS	21
6.2 CLOCK GENERATOR	21
6.3 CONTROL FUNCTIONS OF SUBSYSTEM CLOCK OSCILLATOR	23
6.4 CLOCK OUTPUT CIRCUIT	24
6.5 BASIC INTERVAL TIMER/WATCHDOG TIMER	25
6.6 CLOCK TIMER	26
6.7 TIMER/EVENT COUNTER	27
6.8 SERIAL INTERFACE	30
6.9 BIT SEQUENTIAL BUFFER	32
7. INTERRUPT FUNCTIONS AND TEST FUNCTIONS	33
8. STANDBY FUNCTION	35
9. RESET FUNCTION	36
10. MASK OPTION	39
11. INSTRUCTION SET	40
12. ELECTRICAL CHARACTERISTICS	53
13. CHARACTERISTIC CURVE (REFERENCE VALUES)	67

14. PACKAGE DRAWINGS	70
15. RECOMMENDED SOLDERING CONDITIONS	73
APPENDIX A FUNCTIONS OF THE μ PD75008, μ PD75008, AND μ PD75P0016	74
APPENDIX B DEVELOPMENT TOOLS	76
APPENDIX C RELATED DOCUMENTS	80

1. PIN CONFIGURATION (TOP VIEW)

- 42-pin plastic shrink DIP (600 mil, 1.778 mm pitch)

μPD750004CU-xxx, μPD750004CU(A)-xxx
 μPD750006CU-xxx, μPD750006CU(A)-xxx
 μPD750008CU-xxx, μPD750008CU(A)-xxx

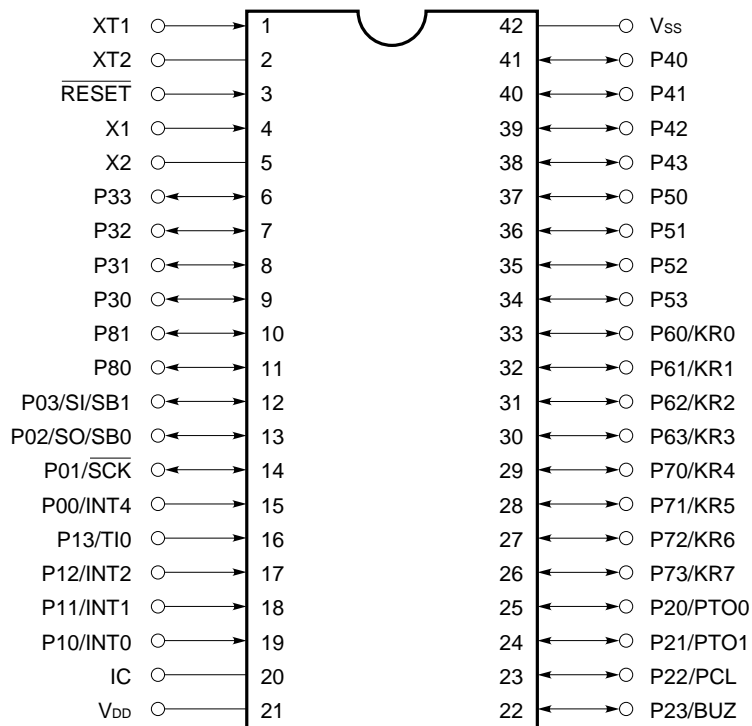

IC : Internally connected (Connect directly to V_{DD}.)

• 44-pin plastic QFP (10 × 10 mm, 0.8 mm pitch)

μPD750004GB-xxx-3BS-MTX, μPD750004GB(A)-xxx-3BS-MTX

μPD750006GB-xxx-3BS-MTX, μPD750006GB(A)-xxx-3BS-MTX

μPD750008GB-xxx-3BS-MTX, μPD750008GB(A)-xxx-3BS-MTX

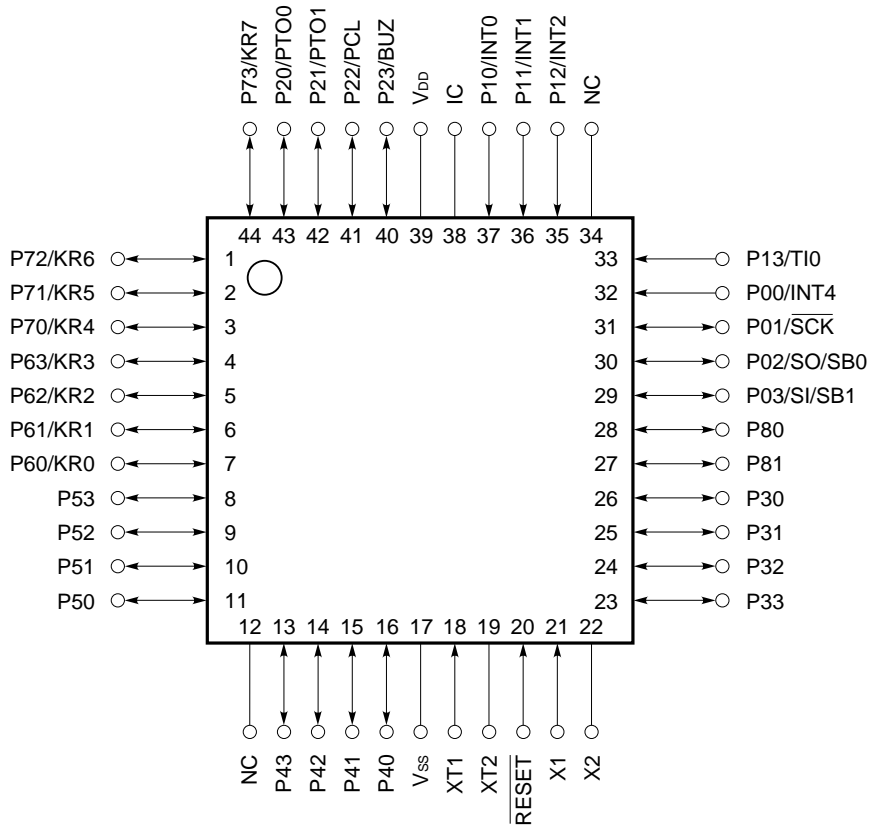

IC : Internally connected (Connect directly to V_{DD}.)

PIN NAMES

P00 - 03	: Port 0	SO	: Serial Output
P10 - 13	: Port 1	SB0, SB1	: Serial Data Bus 0, 1
P20 - 23	: Port 2	RESET	: Reset
P30 - 33	: Port 3	TI0	: Timer Input 0
P40 - 43	: Port 4	PTO0, PTO1	: Programmable Timer Output 0, 1
P50 - 53	: Port 5	BUZ	: Buzzer Clock
P60 - 63	: Port 6	PCL	: Programmable Clock
P70 - 73	: Port 7	INT0, 1, 4	: External Vectored Interrupt 0, 1, 4
P80, 81	: Port 8	INT2	: External Test Input 2
KR0 - KR7	: Key Return 0 - 7	X1, X2	: Main System Clock Oscillation 1, 2
SCK	: Serial Clock	XT1, XT2	: Subsystem Clock Oscillation 1, 2
SI	: Serial Input	NC	: No Connection
		IC	: Internally Connected

2. BLOCK DIAGRAM

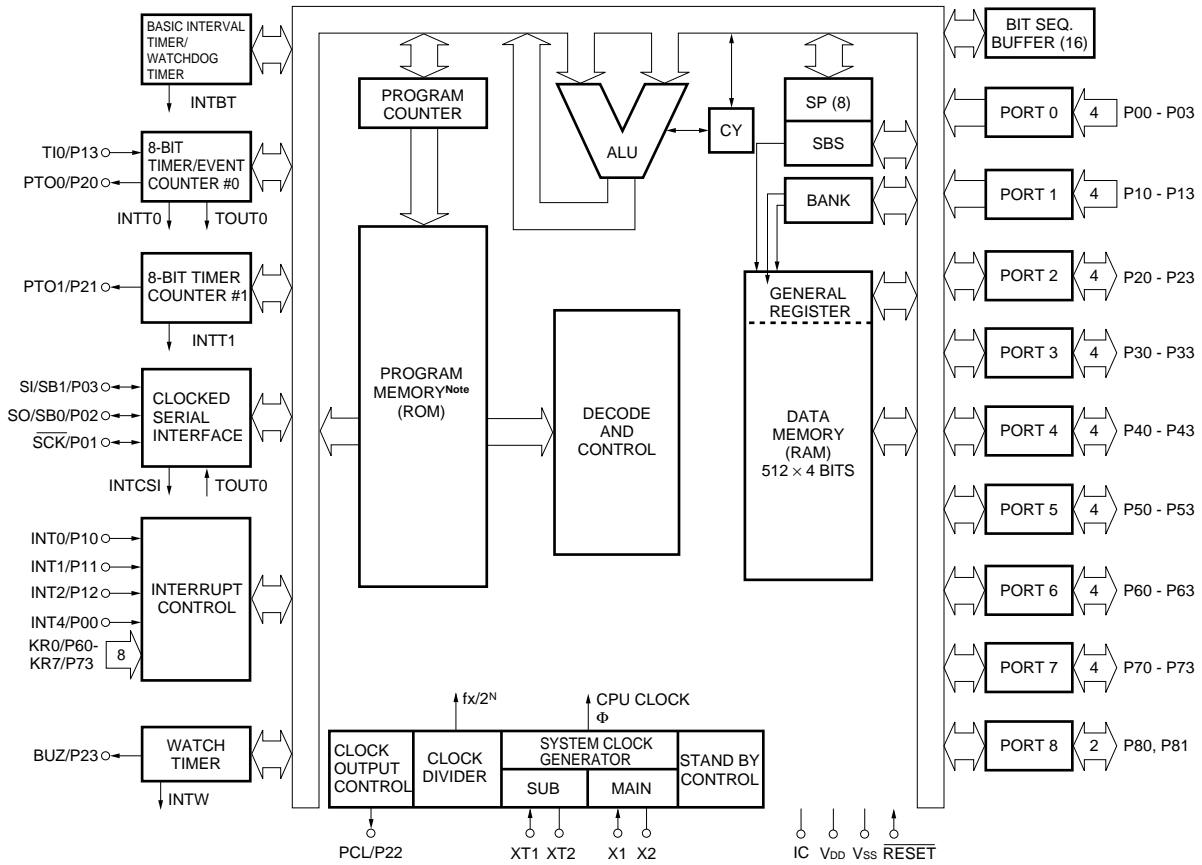

Note The ROM capacity depends on the product.

3. PIN FUNCTIONS

3.1 PORT PINS

Pin name	Input/output	Shared pin	Function	8-bit I/O	When reset	I/O circuit type ^{Note 1}
P00	Input	INT4	4-bit input port (PORT0). For P01 - P03, built-in pull-up resistors can be connected by software in units of 3 bits.	×	Input	ⓑ
P01	I/O	SCK				Ⓕ-A
P02	I/O	SO/SB0				Ⓕ-B
P03	I/O	SI/SB1				Ⓜ-C
P10	Input	INT0	4-bit input port (PORT1). Built-in pull-up resistors can be connected by software in units of 4 bits. A noise eliminator can be selected only when the P10/INT0 pin is used.	×	Input	ⓑ-C
P11		INT1				
P12		INT2				
P13		TI0				
P20	I/O	PTO0	4-bit I/O port (PORT2). Built-in pull-up resistors can be connected by software in units of 4 bits.	×	Input	E-B
P21		PTO1				
P22		PCL				
P23		BUZ				
P30 - P33	I/O	-	Programmable 4-bit I/O port (PORT3). I/O can be specified bit by bit. Built-in pull-up resistors can be connected by software in units of 4 bits.	×	Input	E-B
P40 - P43 ^{Notes 2}	I/O	-	N-ch open-drain 4-bit I/O port (PORT4). A pull-up resistor can be provided bit by bit (mask option). Withstand voltage is 13 V in open-drain mode.	○	High level (when pull-up resistors are provided) or high impedance	M-D
P50 - P53 ^{Notes 2}	I/O	-	N-ch open-drain 4-bit I/O port (PORT5). A pull-up resistor can be provided bit by bit (mask option). Withstand voltage is 13 V in open-drain mode.		High level (when pull-up resistors are provided) or high impedance	M-D
P60	I/O	KR0	Programmable 4-bit I/O port (PORT6). I/O can be specified bit by bit. Built-in pull-up resistors can be connected by software in units of 4 bits.	○	Input	Ⓕ-A
P61		KR1				
P62		KR2				
P63		KR3				
P70	I/O	KR4	4-bit I/O port (PORT7). Built-in pull-up resistors can be connected by software in units of 4 bits.	○	Input	Ⓕ-A
P71		KR5				
P72		KR6				
P73		KR7				
P80	I/O	-	2-bit I/O port (PORT8). Built-in pull-up resistors can be connected by software in units of 2 bits.	×	Input	E-B
P81		-				

Notes 1. The circle (○) indicates the Schmitt trigger input.

2. When pull-up resistors that can be specified with the mask option are not incorporated (when pins are used as N-ch open-drain input ports), the input leak low current increases when an input instruction or bit operation instruction is executed.

3.2 NON-PORT PINS

Pin name	Input/output	Shared pin	Function	When reset	I/O circuit type ^{Note 1}
T10	Input	P13	Inputs external event pulse to the timer/event counter	Input	ⓑ-C
PTO0	Output	P20	Timer/event counter output	Input	E-B
PTO1		P21	Timer counter output		
PCL		P22	Clock output		
BUZ		P23	Arbitrary frequency output (for buzzer output or system clock trimming)		
SCK	I/O	P01	Serial clock I/O	Input	ⓕ-A
SO/SB0		P02	Serial data output Serial data bus I/O		ⓕ-B
SI/SB1		P03	Serial data input Serial data bus I/O		Ⓜ-C
INT4	Input	P00	Edge detection vectored interrupt input (both rising and falling edges are detected)		ⓑ
INT0	Input	P10	Edge detection vectored interrupt input (detection edge selectable). A noise eliminator can be selected when INT0/P10 is used.	Input	ⓑ-C
INT1		P11			
INT2	Input	P12	Rising edge detection testable input		
KR0 - KR3	I/O	P60 - P63	Falling edge detection testable input	Input	ⓕ-A
KR4 - KR7	I/O	P70 - P73	Falling edge detection testable input	Input	ⓕ-A
X1	Input	-	Crystal/ceramic connection pin for main system clock generation. When external clock signal is used, it is applied to X1, and its reverse phase signal is applied to X2.	-	-
X2	-				
XT1	Input	-	Crystal connection pin for subsystem clock generation. When external clock signal is used, it is applied to XT1, and its reverse phase signal is applied to XT2. XT1 can be used as a 1-bit input (test).	-	-
XT2	-				
RESET	Input	-	System reset input (active low)	-	ⓑ
IC	-	-	Internally connected. (To be connected directly to V _{DD})	-	-
V _{DD}	-	-	Positive power supply	-	-
V _{SS}	-	-	Ground potential	-	-

- Notes 1.** The circle (○) indicates the Schmitt trigger input.
2. With a noise eliminator/asynchronously selectable
3. Asynchronous

3.3 PIN INPUT/OUTPUT CIRCUITS

The input/output circuit of each μ PD750008 pin is shown below in a simplified manner.

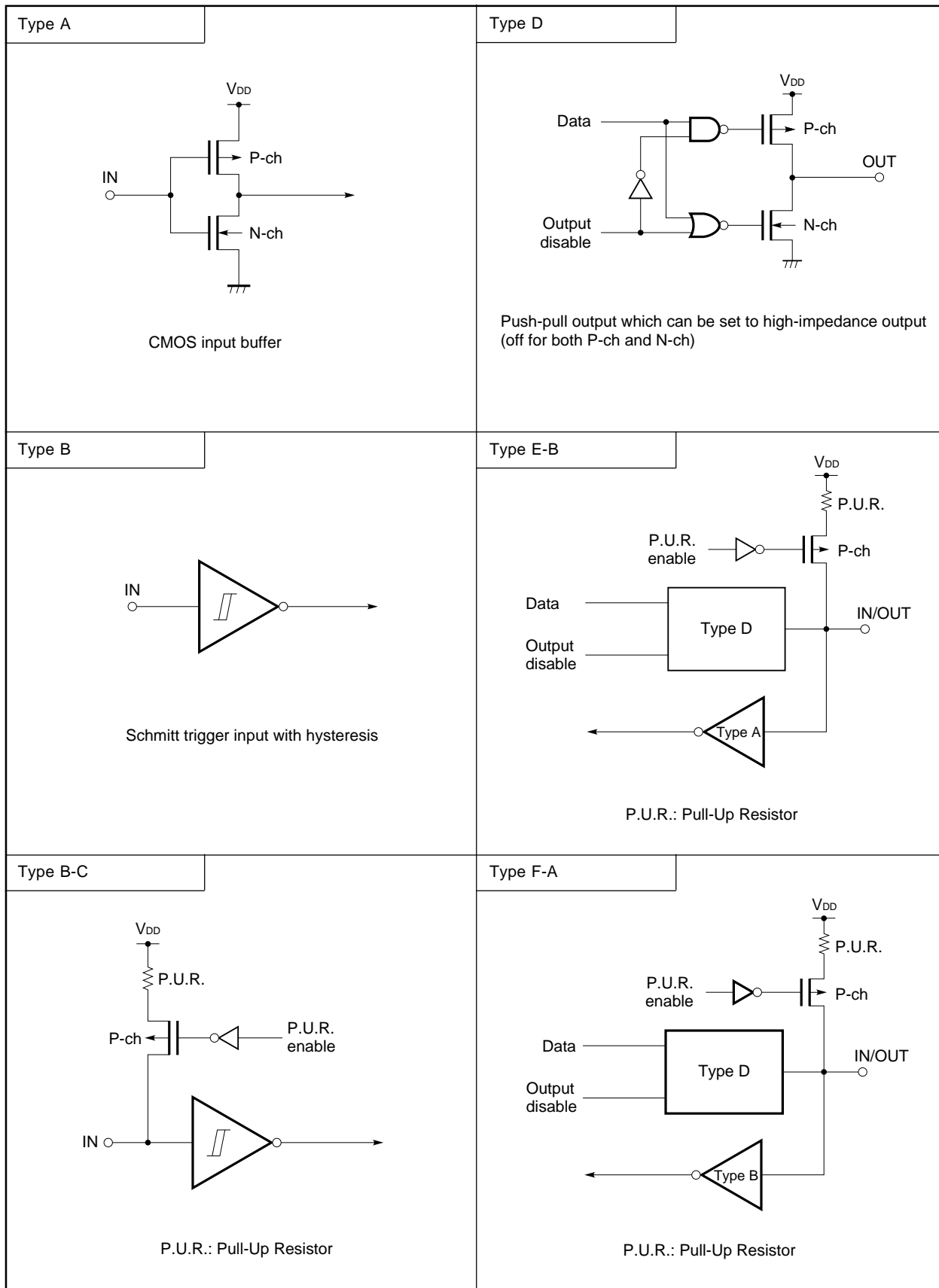

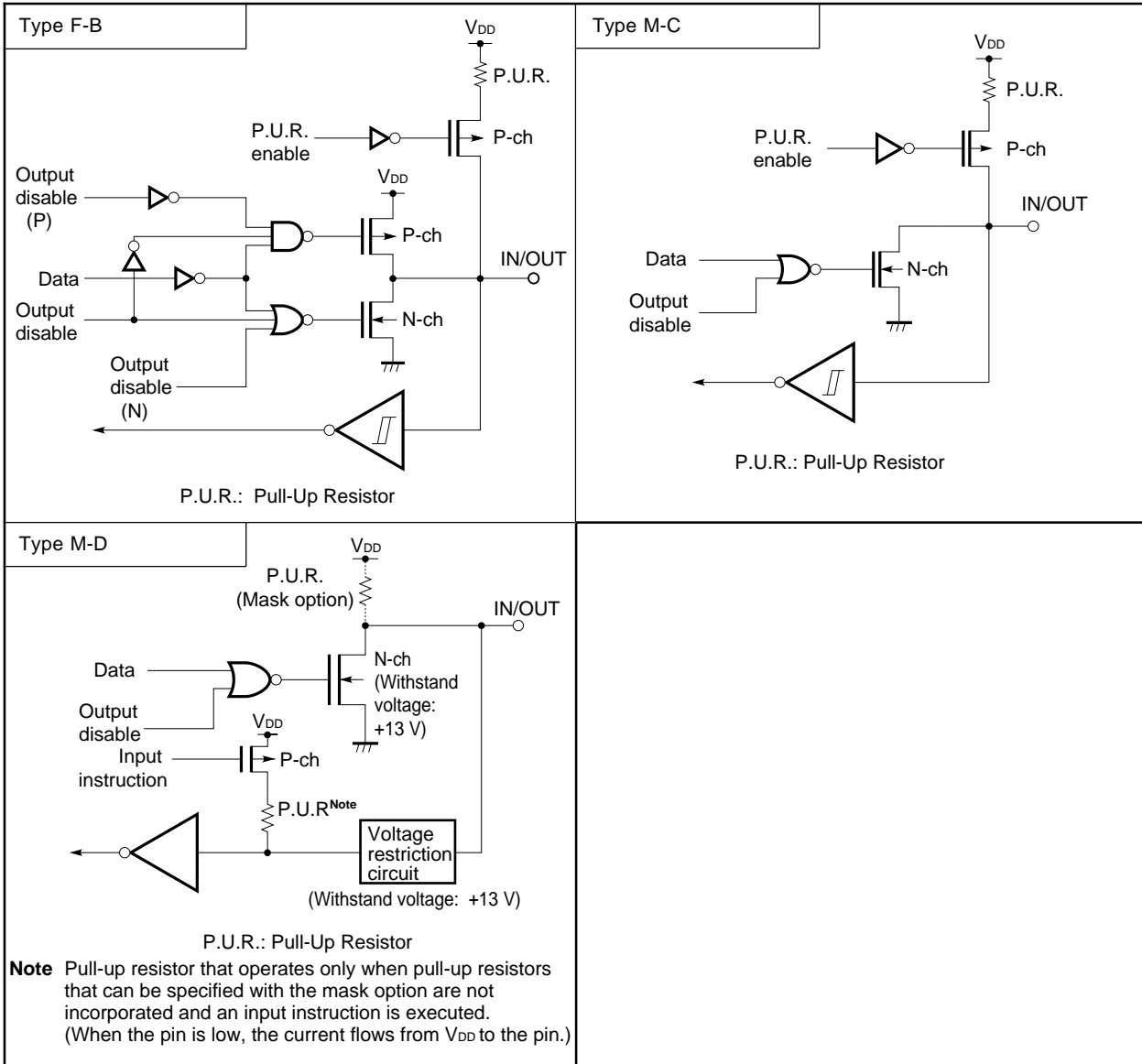

3.4 CONNECTION OF UNUSED PINS

★

Table 3-1 Connection of Unused Pins

Pin name	Recommended connection
P00/INT4	To be connected to V _{SS} or V _{DD}
P01/SCK	To be connected to V _{SS} or V _{DD} through a separate resistor
P02/SO/SB0	
P03/SI/SB1	To be connected to V _{SS}
P10/INT0 - P12/INT2	To be connected to V _{SS} or V _{DD}
P13/TI0	
P20/PTO0	Input state : To be connected to V _{SS} or V _{DD} through a separate resistor Output state : To be left open
P21/PTO1	
P22/PCL	
P23/BUZ	
P30 - P33	
P40 - P43	Input state : To be connected to V _{SS} Output state : To be connected to V _{SS} (Do not connect to a pull-up resistor specified with a mask option.)
P50 - P53	
P60/KR0 - P63/KR3	Input state : To be connected to V _{SS} or V _{DD} through a separate resistor Output state : To be left open
P70/KR4 - P73/KR7	
P80, P81	
XT1 ^{Note}	To be connected to V _{SS}
XT2 ^{Note}	To be left open
IC	To be connected directly to V _{DD}

Note When the subsystem clock is not used, set SOS.0 to 1 (not to use the built-in feedback resistor).

4. Mk I MODE/Mk II MODE SWITCH FUNCTION

4.1 DIFFERENCES BETWEEN Mk I MODE AND Mk II MODE

The CPU of the μPD750008 has two modes (Mk I mode and Mk II mode) and which mode is used is selectable. Bit 3 of the stack bank selection register (SBS) determines the mode.

- Mk I mode: This mode has the upward compatibility with the μPD75008. It can be used in the 75XL CPUs having a ROM of up to 16 KB.
- Mk II mode: This mode is not compatible with the μPD75008. It can be used in all 75XL CPUs, including those having a ROM of 16 KB or more.

Table 4-1 shows the differences between Mk I mode and Mk II mode.

Table 4-1 Differences between Mk I Mode and Mk II Mode

	Mk I mode	Mk II mode
Number of stack bytes in a subroutine instruction	2 bytes	3 bytes
BRA !addr1 instruction CALLA !addr1 instruction	None	Available
CALL !addr instruction	3 machine cycles	4 machine cycles
CALLF !faddr instruction	2 machine cycles	3 machine cycles

- ★ **Caution** Mk II mode can be used to support a program area larger than 16K bytes in the 75X series or 75XL series. This mode enhances a software compatibility with products whose program area is larger than 16K bytes. In Mk II mode, one more stack byte is required for execution of subroutine call instructions per stack compared with Mk I mode. When a CALL !addr or CALLF !faddr instruction is executed, it takes one more machine cycle. Therefore, Mk I mode should be used for applications for which RAM efficiency or processing capabilities is more critical than a software compatibility.

4.2 SETTING OF THE STACK BANK SELECTION REGISTER (SBS)

The Mk I mode and Mk II mode are switched by stack bank selection register. Fig. 4-1 shows the register configuration.

The stack bank selection register is set with a 4-bit memory operation instruction. To use the CPU in Mk I mode, initialize the register to 100×B^{Note} at the beginning of the program. To use the CPU in Mk II mode, initialize it to 000×B^{Note}.

Note Specify the desired value in x.

Fig. 4-1 Stack Bank Selection Register Format

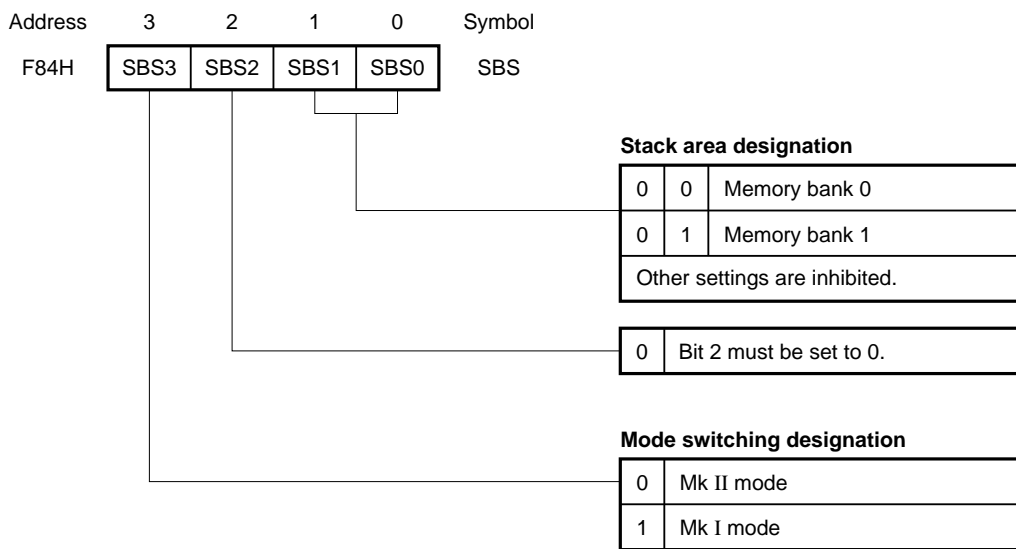

Caution The CPU operates in Mk I mode after the RESET signal is issued, because bit 3 of SBS is set to 1. Set bit 3 of SBS to 0 (Mk II mode) to use the CPU in Mk II mode.

5. MEMORY CONFIGURATION

- **Program memory (ROM) :** 4096 × 8 bits (0000H-0FFFH): μ PD750004
6144 × 8 bits (0000H-17FFH): μ PD750006
8192 × 8 bits (0000H-1FFFH): μ PD750008
- 0000H to 0001H
Vector address table for holding the RBE and MBE values and program start address when a $\overline{\text{RESET}}$ signal is issued (allowing a reset start at an arbitrary address)
- 0002H to 000DH
Vector address table for holding the RBE and MBE values and program start address for each vectored interrupt (allowing interrupt processing to be started at an arbitrary address)
- 0020H to 007FH
Table area referenced by the GETI instruction
- **Data memory (RAM)**
 - Data area : 512 × 4 bits (000H to 1FFH)
 - Peripheral hardware area: 128 × 4 bits (F80H to FFFH)

Fig. 5-1 Program Memory Map (in μPD750004)

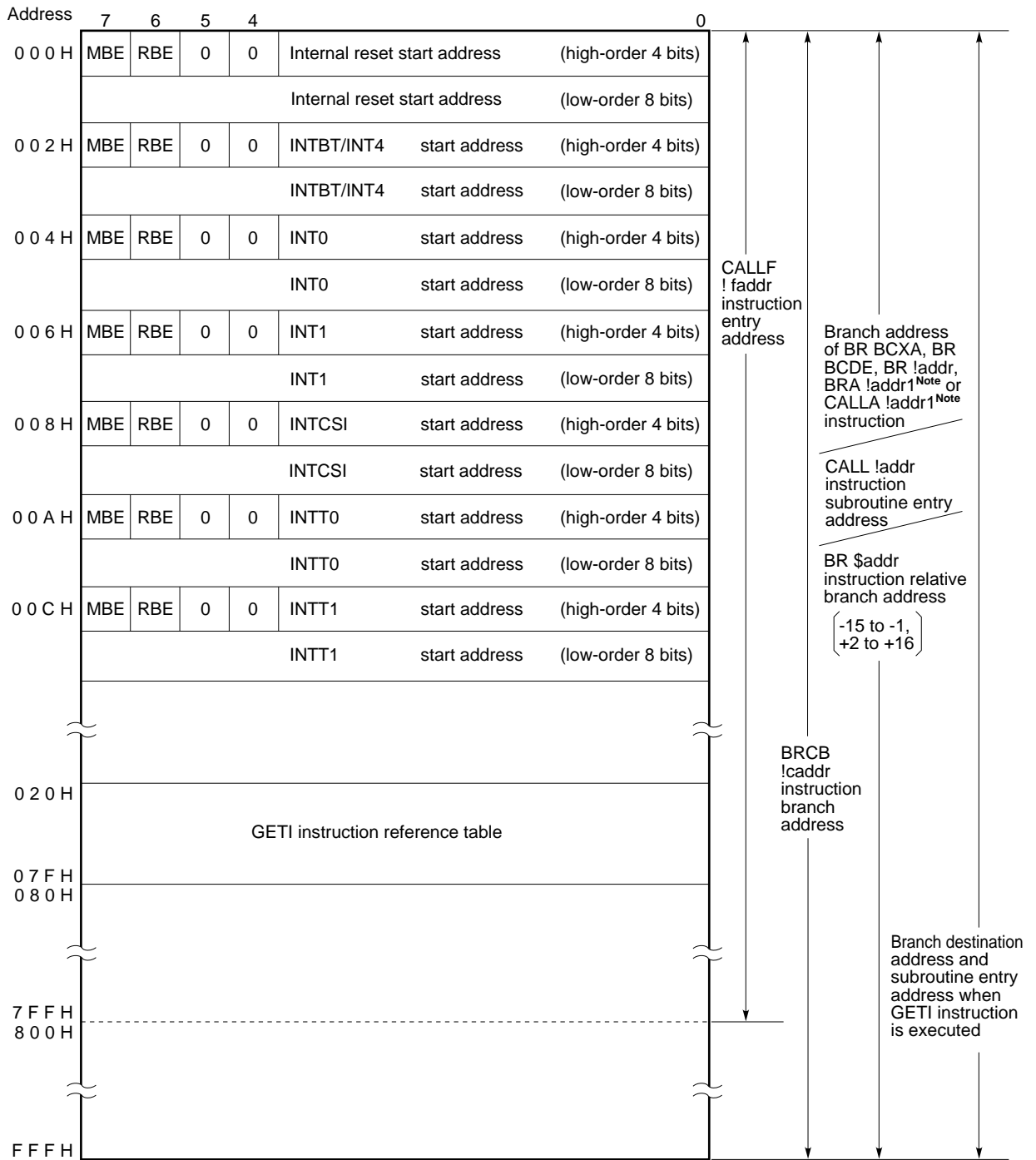

Note Can be used only in the Mk II mode.

Remark In addition to the above, the BR PCDE and BR PCXA instructions can cause a branch to an address with only the 8 low-order bits of the PC changed.

Fig. 5-2 Program Memory Map (in μPD750006)

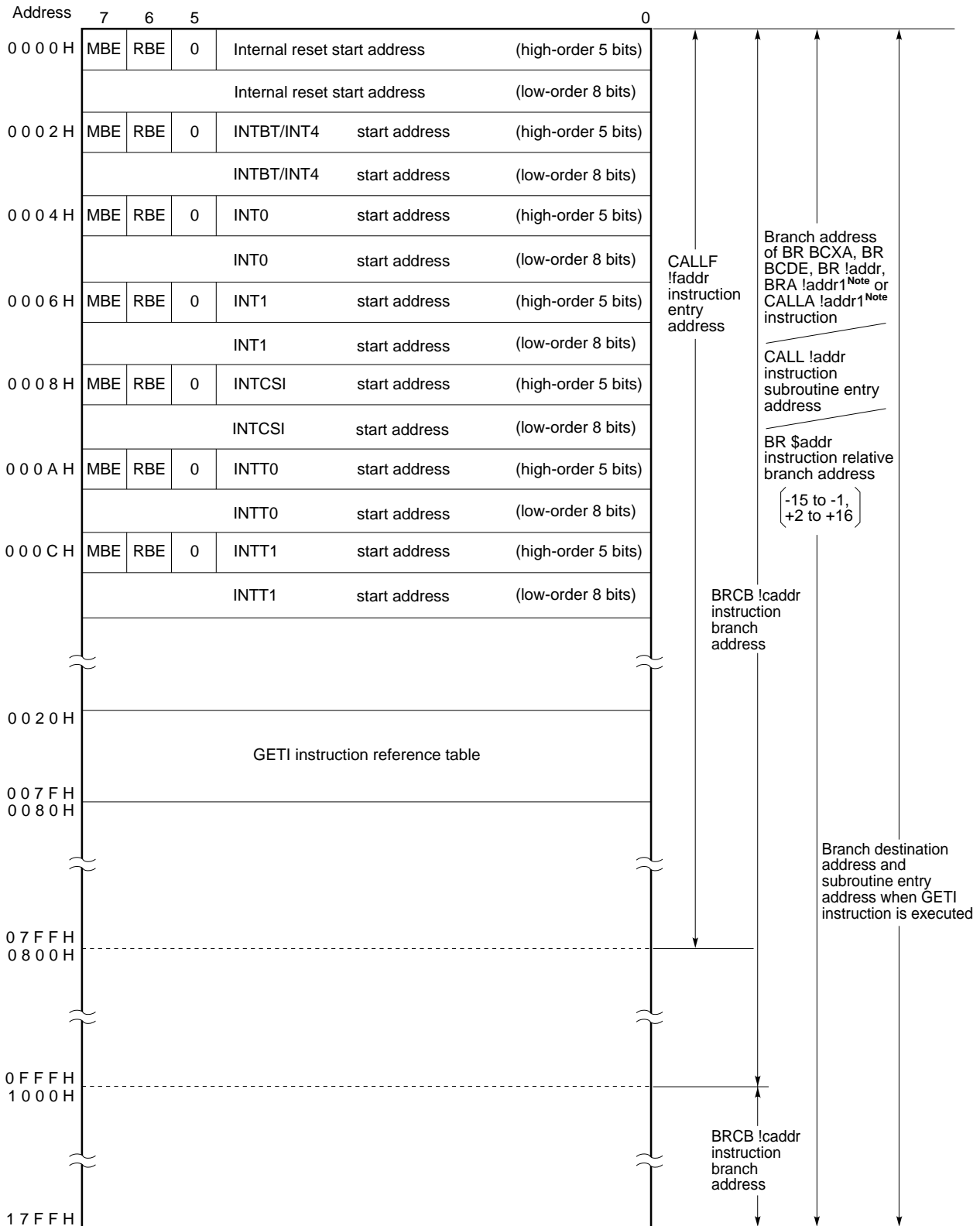

Note Can be used only in the Mk II mode.

Remark In addition to the above, the BR PCDE and BR PCXA instructions can cause a branch to an address with only the 8 low-order bits of the PC changed.

Fig. 5-3 Program Memory Map (in μPD750008)

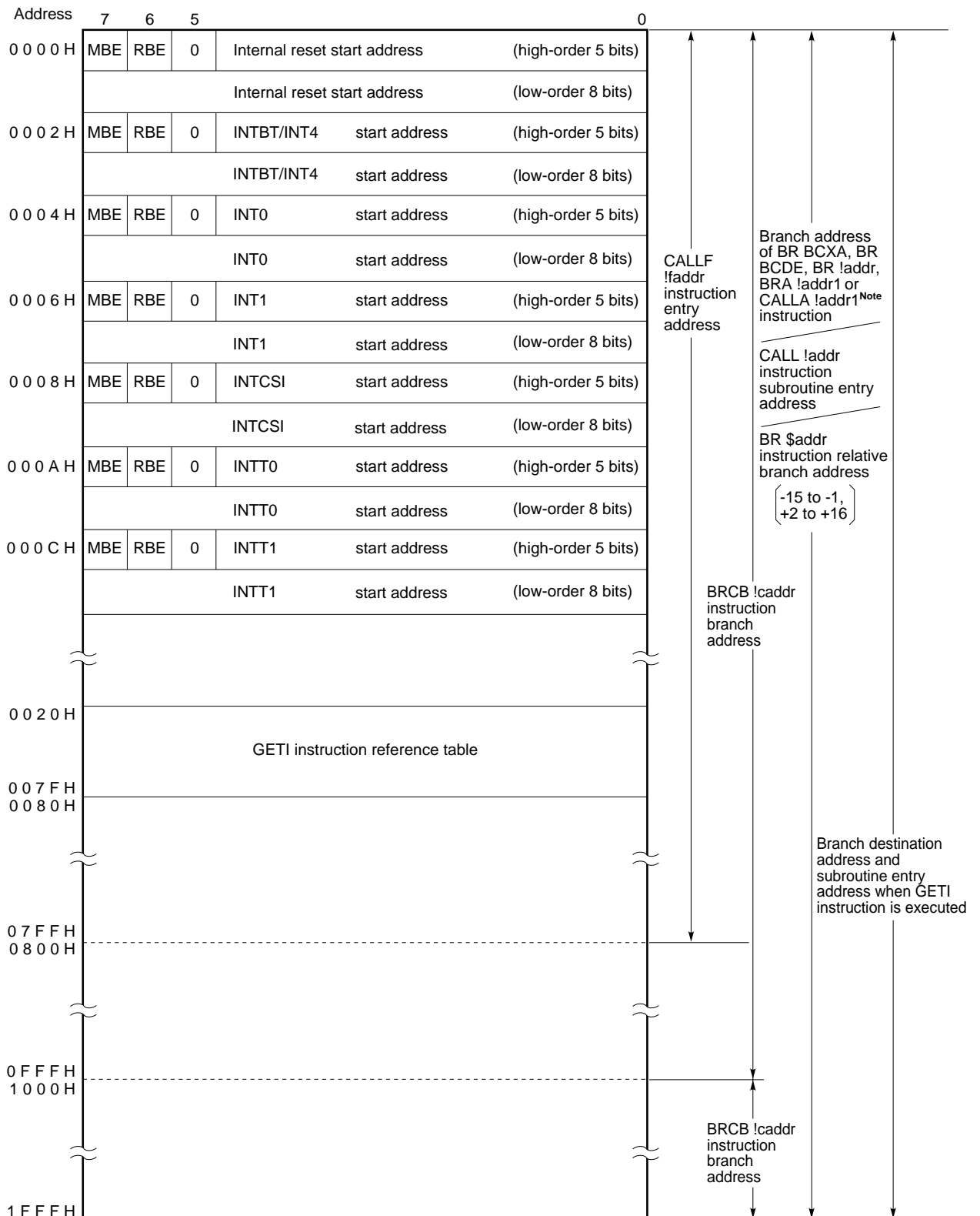

Note Can be used only in the Mk II mode.

Remark In addition to the above, the BR PCDE and BR PCXA instructions can cause a branch to an address with only the 8 low-order bits of the PC changed.

Fig. 5-4 Data Memory Map

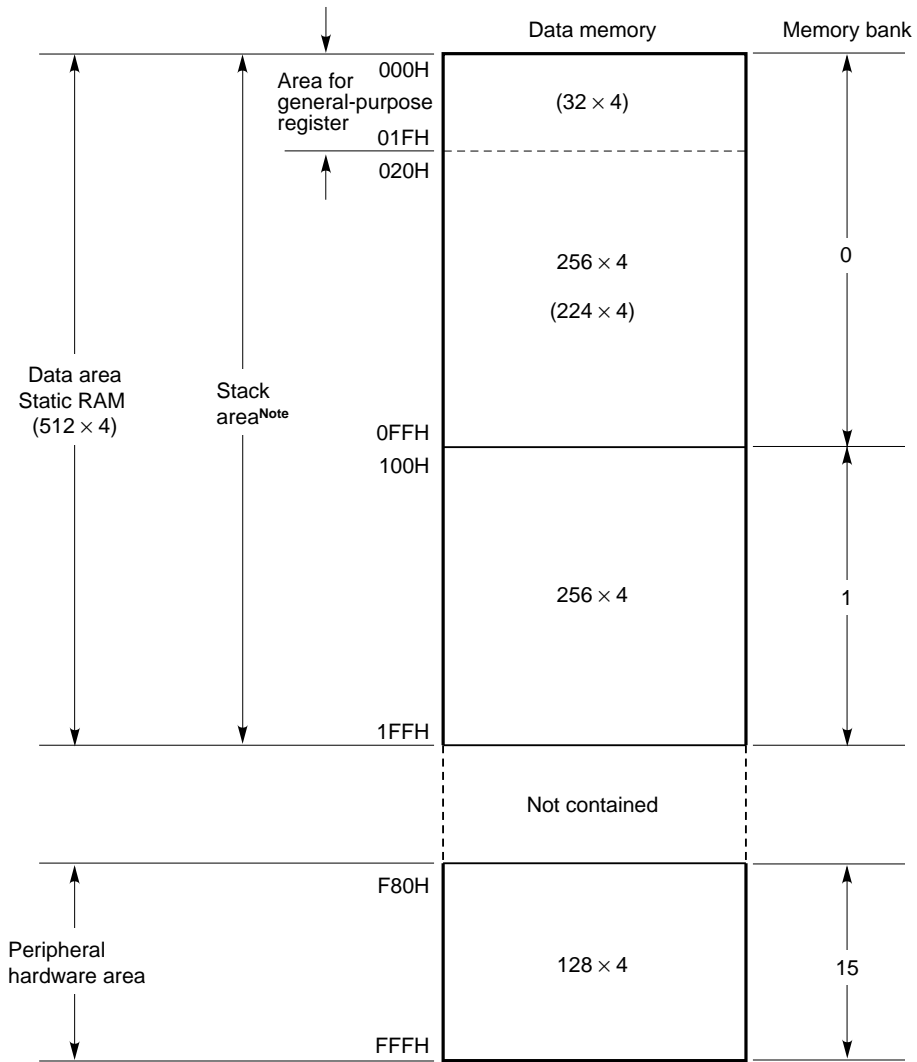

Note Memory bank 0 or 1 can be selected as the stack area.

6. PERIPHERAL HARDWARE FUNCTIONS

6.1 DIGITAL I/O PORTS

The μPD750008 has the following three types of I/O port:

- 8 CMOS input pins (PORT0 and PORT1)
- 18 CMOS I/O pins (PORT2, PORT3, and PORT6 to PORT8)
- 8 N-ch open-drain I/O pins (PORT4 and PORT5)

Total: 34 pins

Table 6-1 Digital Ports and Their Features

Port name	Function	Operation and feature		Remarks
PORT0	4-bit input	When the serial interface function is used, dual-function pins function as output pins in some operation modes.		Also used as INT4, SCK, SO/SB0, or SI/SB1.
PORT1		4-bit input port		
PORT2	4-bit I/O	Allows input or output mode setting in units of 4 bits.		Also used as PTO0, PTO1, PCL, or BUZ.
PORT3		Allows input or output mode setting in units of 1 bit.		
PORT4	4-bit I/O (N-ch open-drain can withstand 13 V)	Allows input or output mode setting in units of 4 bits. Whether to use pull-up resistors can be specified bit by bit with the mask option.	Ports 4 and 5 can be paired, allowing data I/O in units of 8 bits.	-
PORT5				
PORT6	4-bit I/O	Allows input or output mode setting in units of 1 bit.	Ports 6 and 7 can be paired, allowing data I/O in units of 8 bits.	Also used as one of KR0 to KR3.
PORT7		Allows input or output mode setting in units of 4 bits.		Also used as one of KR4 to KR7.
PORT8	2-bit I/O	Allows input or output mode setting in units of 2 bits.		-

6.2 CLOCK GENERATOR

The clock generator generates clocks which are supplied to the peripheral hardware in the CPU. Fig. 6-1 shows the configuration of the clock generator.

Operation of the clock generator is specified by the processor clock control register (PCC) and system clock control register (SCC).

The main system clock and subsystem clock are used.

The instruction execution time can be made variable.

- 0.95 μs, 1.91 μs, 3.81 μs, 15.3 μs (when the main system clock is at 4.19 MHz)
- 0.67 μs, 1.33 μs, 2.67 μs, 10.7 μs (when the main system clock is at 6.0 MHz)
- 122 μs (when the subsystem clock is at 32.768 kHz)

Fig. 6-1 Clock Generator Block Diagram

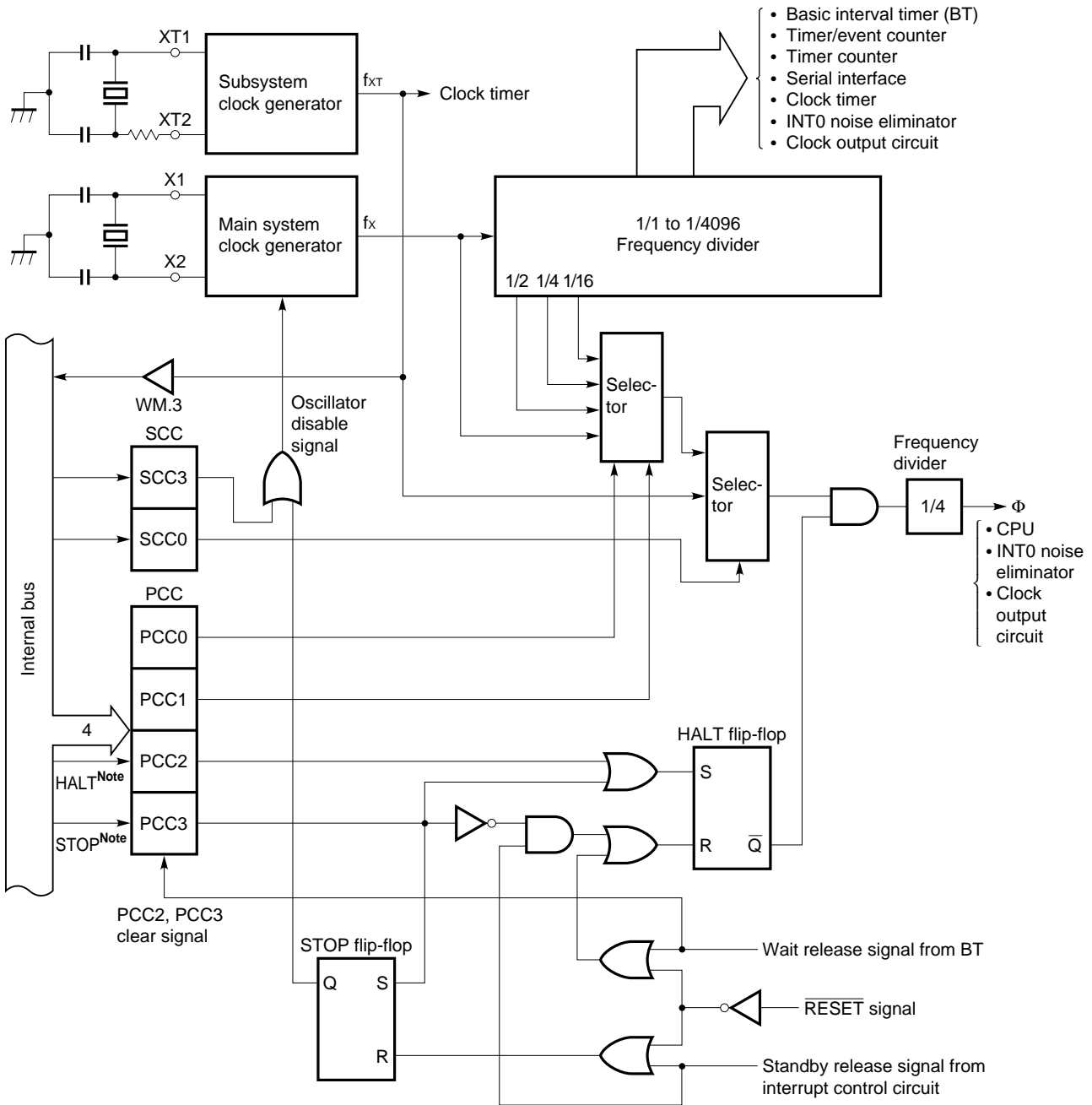

Note Instruction execution

- Remarks 1.** f_x = Main system clock frequency
 2. f_{XT} = Subsystem clock frequency
 3. Φ = CPU clock
 4. PCC: Processor clock control register
 5. SCC: System clock control register
 6. One clock cycle (t_{CY}) of the CPU clock (Φ) is equal to one machine cycle of an instruction.

6.3 CONTROL FUNCTIONS OF SUBSYSTEM CLOCK OSCILLATOR

The subsystem clock oscillator of the μ PD750008 subseries has two control functions to decrease the supply current.

- The function to select with the software whether to use the built-in feedback resistor^{Note}
- The function to suppress the supply current by reducing the drive current of the built-in inverter when the supply voltage is high ($V_{DD} \geq 2.7$ V)

★ **Note** When the subsystem clock is not used, set SOS.0 to 1 (not to use the built-in feedback resistor), connect XT1 to V_{SS} , and open XT2. This makes it possible to reduce the supply current required by the subsystem clock oscillator.

Each function can be used by switching bits 0 and 1 in the sub-oscillator control register (SOS). (See Fig. 6-2.)

Fig. 6-2 Subsystem Clock Oscillator

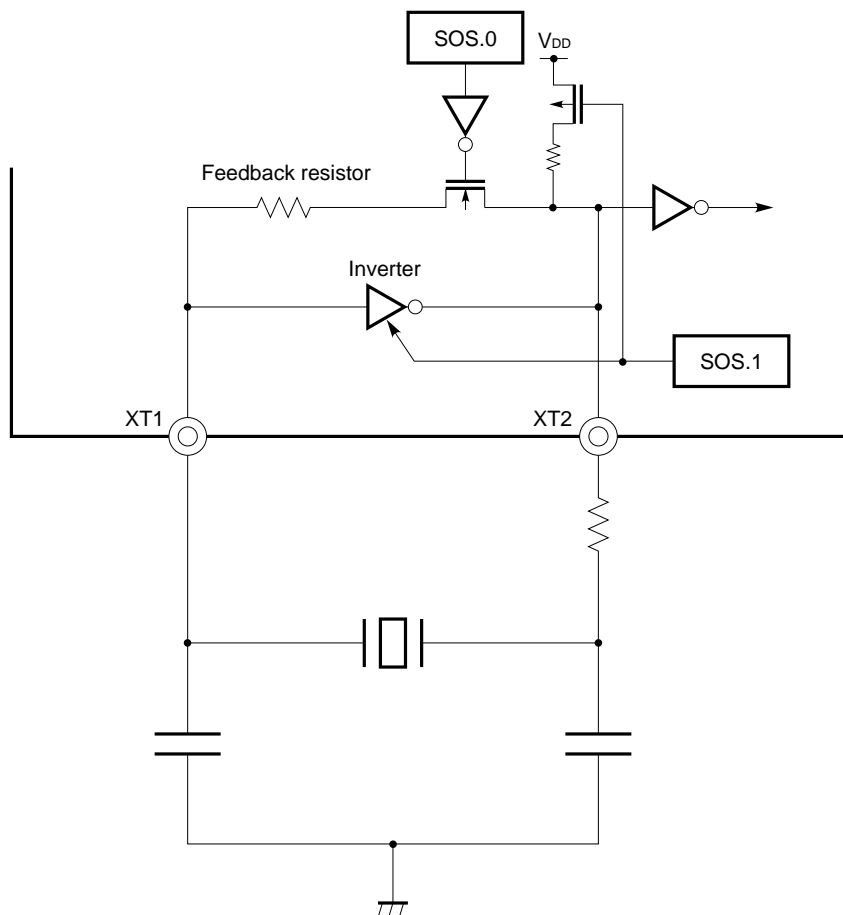

6.4 CLOCK OUTPUT CIRCUIT

The clock output circuit outputs a clock pulse from the P22/PCL pin. This clock pulse is used for remote control waveform output, peripheral LSIs, etc.

- Clock output (PCL): Φ , 524, 262, or 65.5 kHz (at 4.19 MHz)
 Φ , 750, 375, or 93.8 kHz (at 6.0 MHz)

Fig. 6-3 Clock Output Circuit Configuration

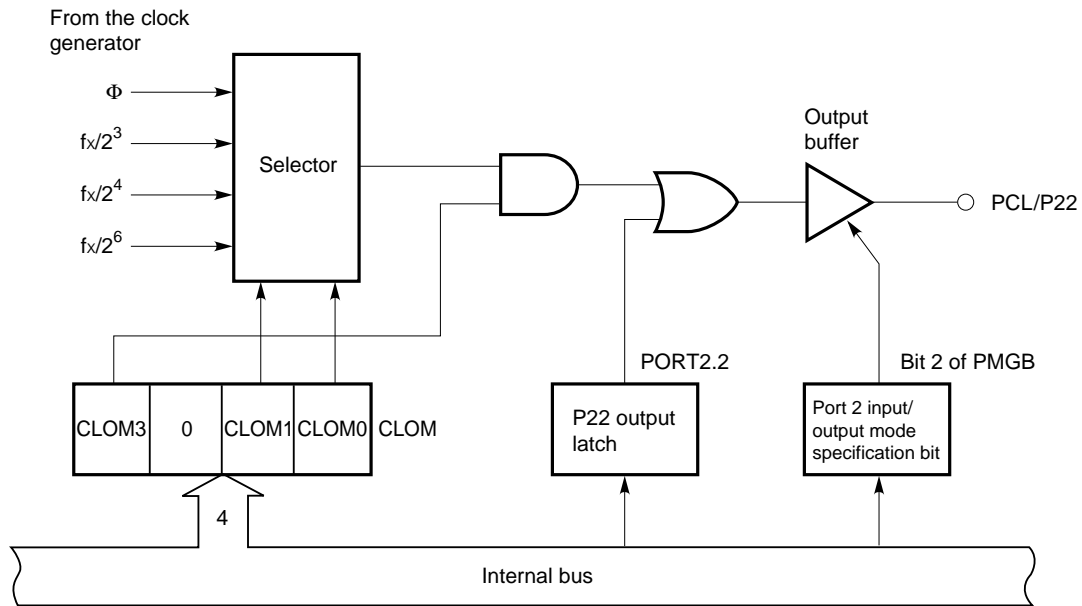

Remark Measures are taken to prevent outputting a narrow pulse when selecting clock output enable/disable.

6.5 BASIC INTERVAL TIMER/WATCHDOG TIMER

The basic interval timer/watchdog timer has these functions:

- Interval timer operation which generates a reference timer interrupt
- Operation as a watchdog timer for detecting program crashes and resetting the CPU
- Selection of wait time for releasing the standby mode and counting the wait time
- Reading out the count value

Fig. 6-4 Block Diagram of the Basic Interval Timer/Watchdog Timer

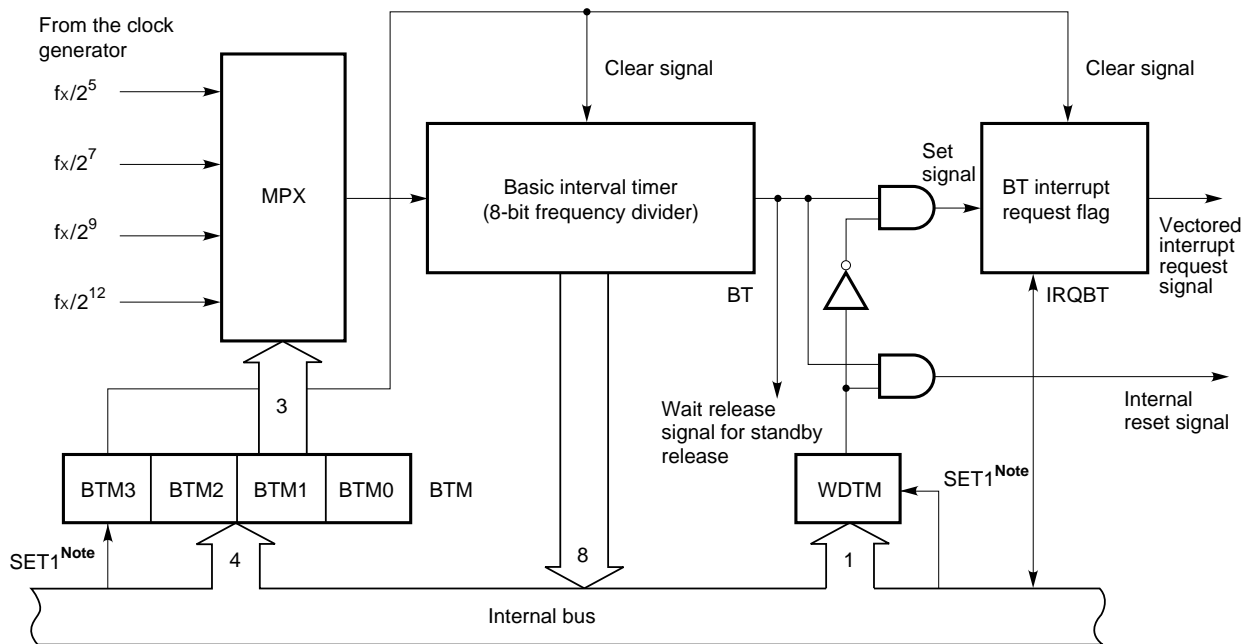

Note Instruction execution

6.6 CLOCK TIMER

The μ PD750008 contains one channel for a clock timer. The clock timer provides the following functions:

- Sets the test flag (IRQW) with a 0.5 sec interval. The standby mode can be released by IRQW.
- The 0.5 second interval can be generated from either the main system clock (4.194304 MHz) or subsystem clock (32.768 kHz).
- The time interval can be made 128 times faster (3.91 ms) by selecting the fast mode. This is convenient for program debugging, testing, etc.
- Any of the frequencies 2.048 kHz, 4.096 kHz, and 32.768 kHz can be output to the P23/BUZ pin. This can be used for beep and system clock frequency trimming.
- The frequency divider circuit can be cleared so that a zero-second start of the clock can be made.

Fig. 6-5 Clock Timer Block Diagram

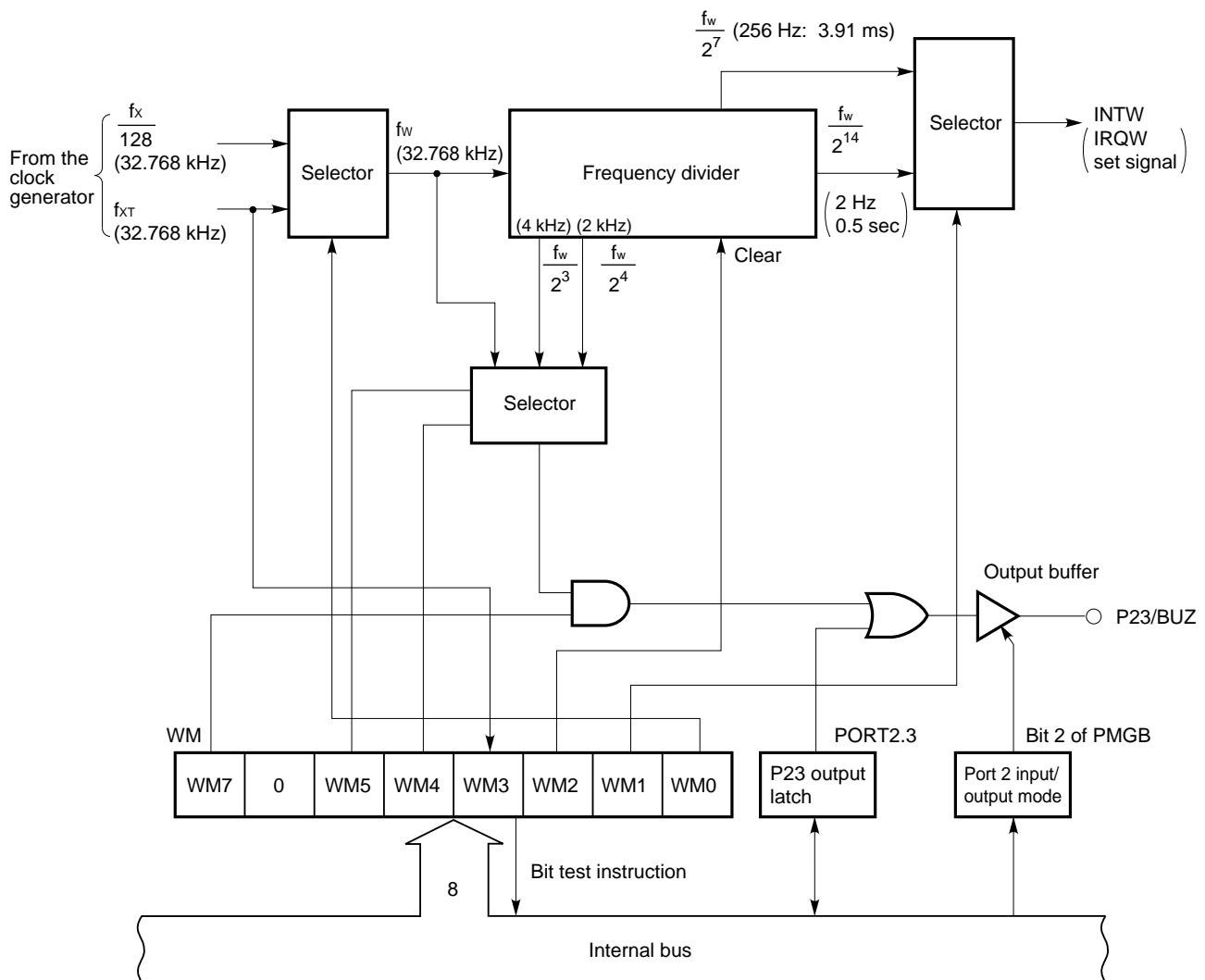

() is for $f_x = 4.194304$ MHz, $f_{XT} = 32.768$ kHz.

6.7 TIMER/EVENT COUNTER

The μ PD750008 contains one channel for a timer/event counter and one channel for a timer counter. Figs. 6-6 and 6-7 show their configurations.

The timer/event counter provides the following functions:

- Programmable interval timer operation
- Outputs square-wave signal of an arbitrary frequency to the PTO_n pin (n = 0, 1)
- Event counter operation (channel 0 only)
- Divides the TI0 pin input by N and outputs to the PTO0 pin (frequency divider operation) (channel 0 only)
- Supplies serial shift clock to the serial interface circuit (channel 0 only)
- Count read function

★ Fig. 6-7 Timer Counter Block Diagram

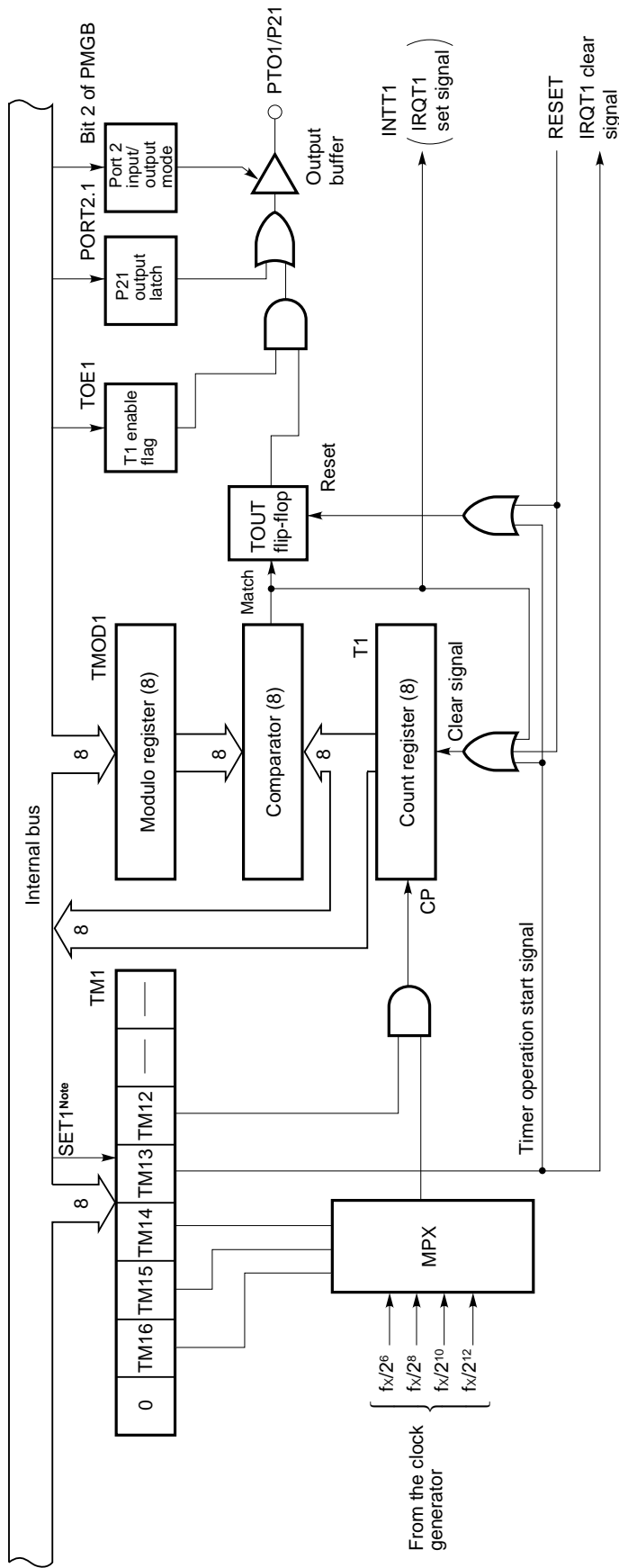

Note Instruction execution

6.8 SERIAL INTERFACE

μ PD750008 has an 8-bit synchronous serial interface. The serial interface has the following four types of mode.

- Operation stop mode
- Three-wire serial I/O mode
- Two-wire serial I/O mode
- SBI mode

Fig. 6-8 Serial Interface Block Diagram

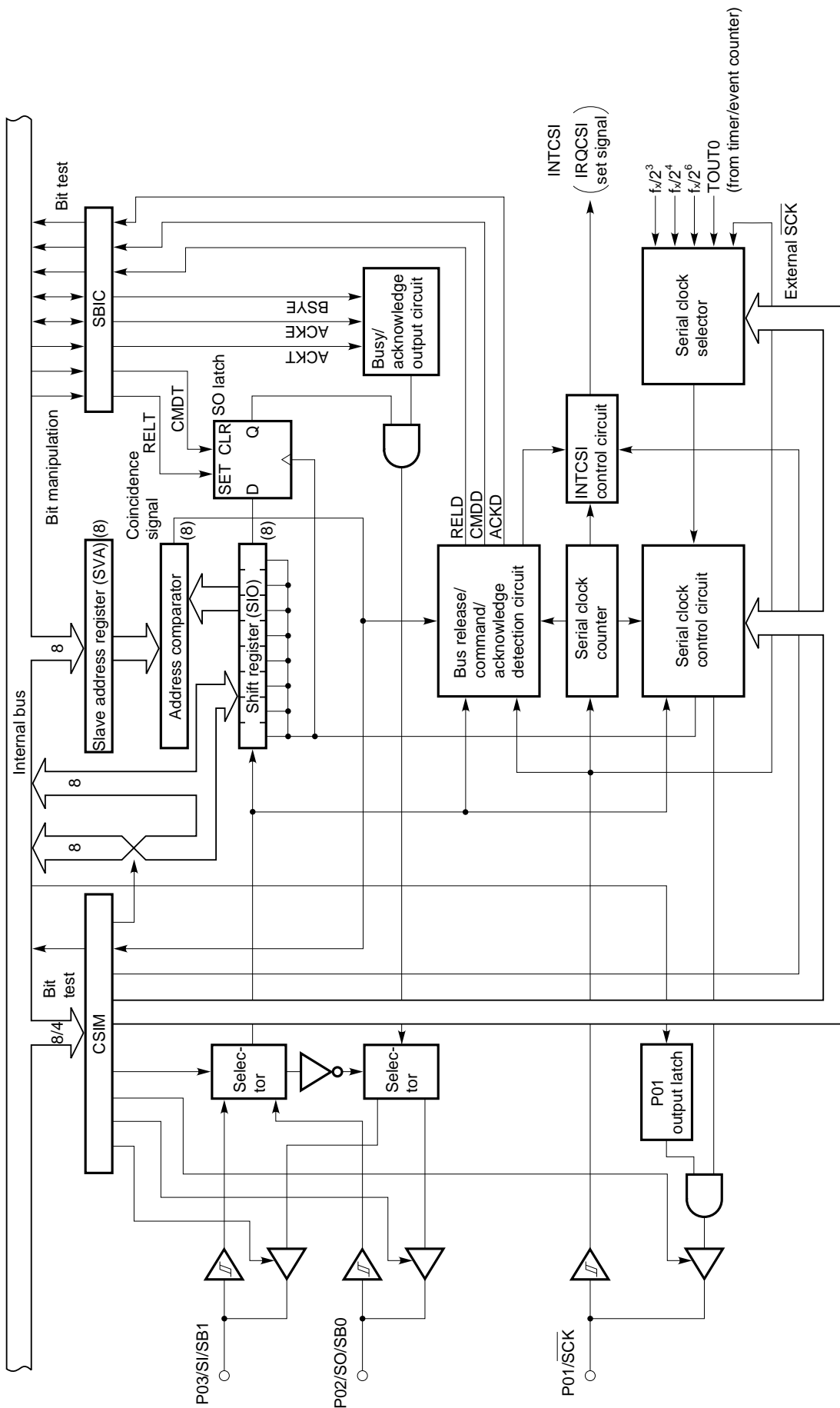

6.9 BIT SEQUENTIAL BUFFER: 16 BITS

The bit sequential buffer (BSB) is a data memory specifically provided for bit manipulation. With this buffer, addresses and bit specifications can be sequentially updated by bit manipulation operation. Therefore, this buffer is very useful for processing long data in bit units.

Fig. 6-9 Bit Sequential Buffer Format

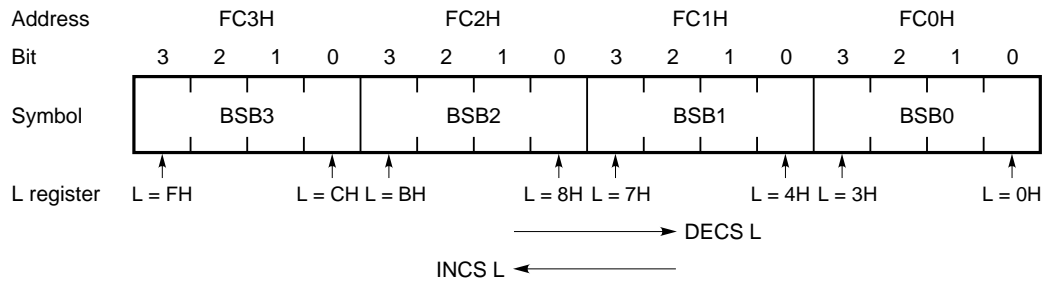

- Remarks 1.** In pmem.@L addressing, bit specification is shifted according to the L register.
- 2.** In pmem.@L addressing, the bit sequential buffer can be manipulated at any time regardless of MBE/MBS specification.

7. INTERRUPT FUNCTIONS AND TEST FUNCTIONS

The μ PD750008 has seven interrupt sources and two test sources. One test source, INT2, has two types of edge detection testable input pins.

The interrupt control circuit of the μ PD750008 has the following functions.

(1) Interrupt functions

- Hardware controlled vectored interrupt function which can control whether or not to accept an interrupt using the interrupt flag (IE $\times\times\times$) and interrupt master enable flag (IME).
- The interrupt start address can be set arbitrarily.
- Multiple interrupt function which can specify the priority by the interrupt priority specification register (IPS)
- Test function of an interrupt request flag (IRQ $\times\times\times$)
(The software can confirm that an interrupt occurred.)
- Release of the standby mode (Interrupts released by an interrupt enable flag can be selected.)

(2) Test functions

- Whether test request flags (IRQ $\times\times\times$) are issued can be checked with software.
- Release of the standby mode (A test source to be released can be selected with test enable flags.)

Fig. 7-1 Interrupt Control Circuit Block Diagram

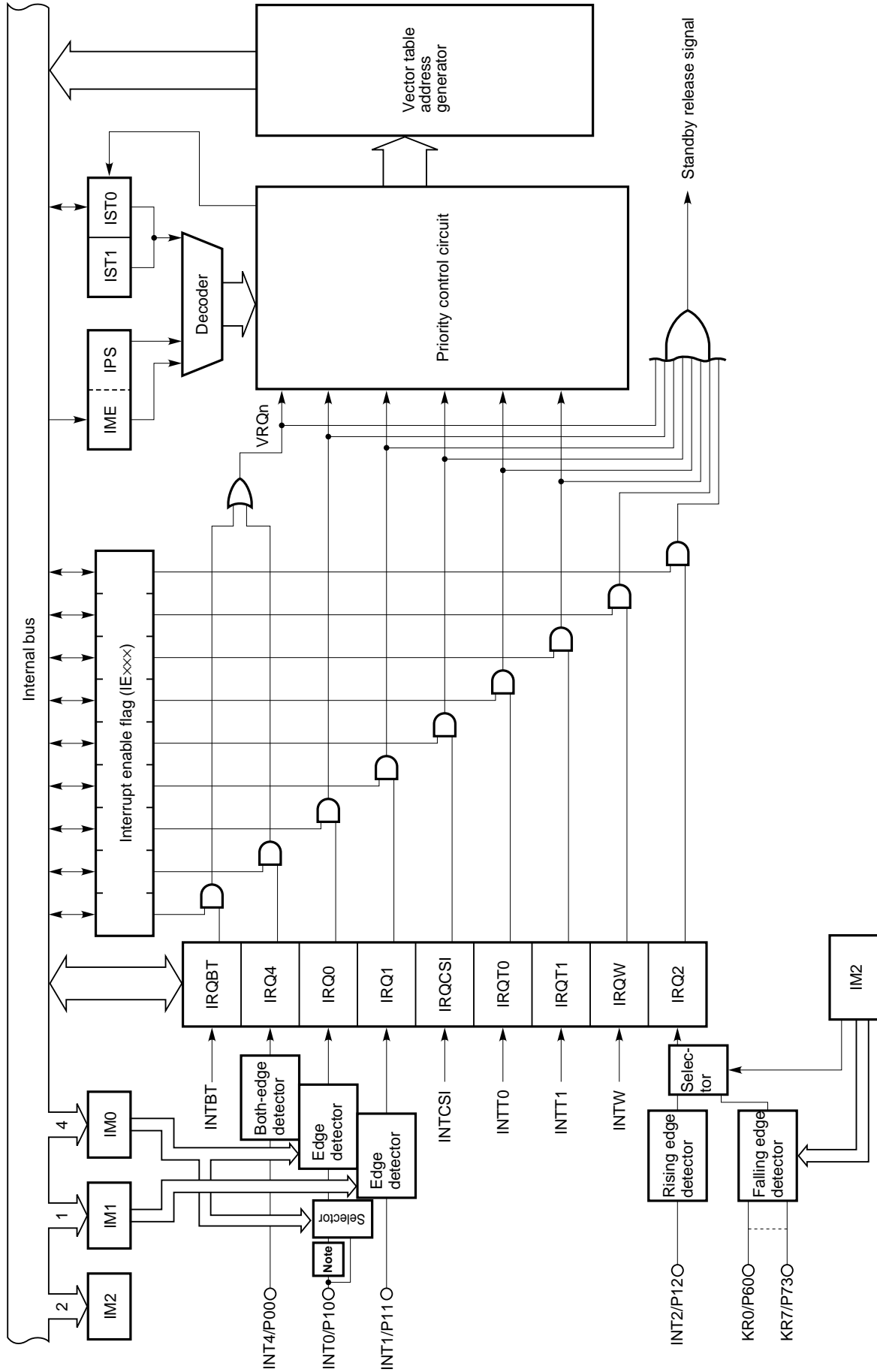

Note Noise eliminator (Standby release is not possible when the noise eliminator is selected.)

8. STANDBY FUNCTION

The μPD750008 has two different standby modes (STOP mode and HALT mode) to reduce power dissipation while waiting for program execution.

Table 8-1 Standby Mode Statuses

Item \ Mode		STOP mode	HALT mode
Instruction for setting		STOP instruction	HALT instruction
System clock for setting		Can be set only when operating on the main system clock.	Can be set either with the main system clock or the subsystem clock.
Operation status	Clock oscillator	The main system clock stops its operation.	Only the CPU clock Φ stops its operation (oscillation continues).
	Basic interval timer/watchdog timer	Does not operate.	Can operate only at main system clock oscillation. (IRQBT is set at reference time intervals.)
	Serial interface	Can operate only when the external \overline{SCK} input is selected for the serial clock.	Can operate only when external \overline{SCK} input is selected as the serial clock or at main system clock oscillation.
	Timer/event counter	Can operate only when the T10 pin input is selected for the count clock.	Can operate only when T10 pin input is specified as the count clock or at main system clock oscillation.
	Timer counter	Does not operate.	Can operate. Note 1
	Clock timer	Can operate when f_{XT} is selected as the count clock.	Can operate.
	External interrupt	INT1, INT2, and INT4 can operate. Only INT0 cannot operate. Note 2	
	CPU	Does not operate.	
Release signal		An interrupt request signal from hardware whose operation is enabled by the interrupt enable flag or the generation of a \overline{RESET} signal	

Notes 1. Operation is possible only when the main system clock operates.

2. Operation is possible only when the noise eliminator is not selected by bit 2 of the edge detection mode register (IM0) (when IM02 = 1).

9. RESET FUNCTION

The μ PD750008 is reset with the external reset signal ($\overline{\text{RESET}}$) or the reset signal received from the basic interval timer/watchdog timer. When either reset signal is input, the internal reset signal is generated. Fig. 9-1 shows the configuration of the reset circuit.

Fig. 9-1 Configuration of Reset Functions

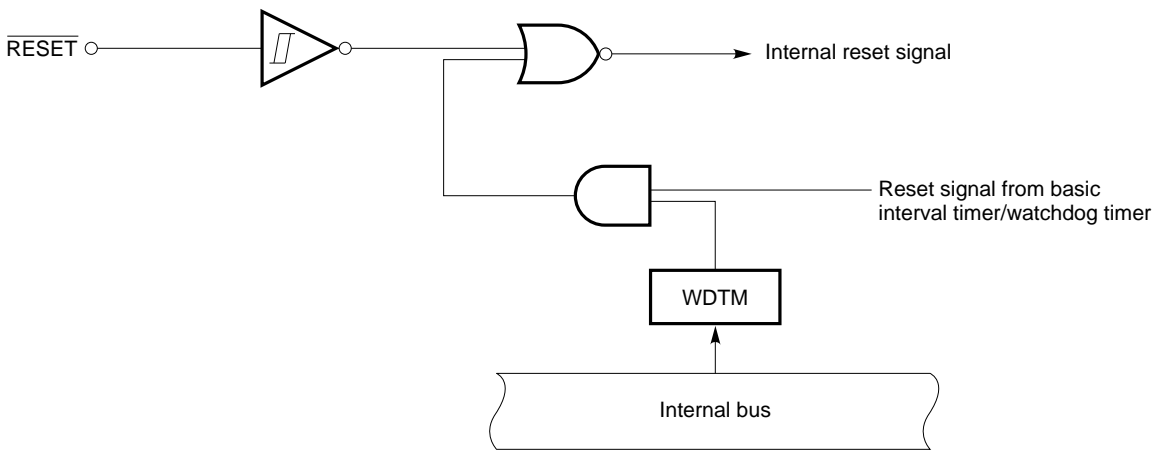

When the $\overline{\text{RESET}}$ signal is generated, all hardware is initialized as indicated in Table 9-1. Fig. 9-2 shows the reset operation timing.

Fig. 9-2 Reset Operation by Generation of $\overline{\text{RESET}}$ Signal

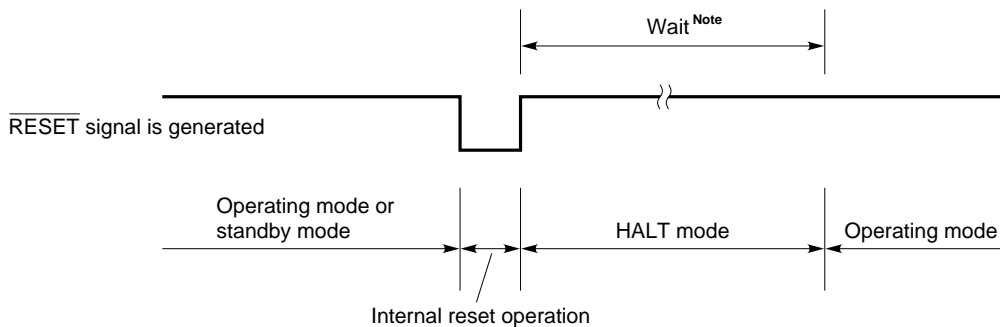

Note Either of the following two values can be selected by a mask option:
 $2^{17}/f_x$ (21.8 ms at 6.0 MHz, 31.3 ms at 4.19 MHz)
 $2^{15}/f_x$ (5.46 ms at 6.0 MHz, 7.81 ms at 4.19 MHz)

Table 9-1 Status of the Hardware after a Reset (1/2)

Hardware		Generation of a $\overline{\text{RESET}}$ signal in a standby mode	Generation of a $\overline{\text{RESET}}$ signal during operation	
Program counter (PC)	μPD750004	4 low-order bits at address 0000H in program memory are set in PC bits 11 to 8, and the data at address 0001H are set in PC bits 7 to 0.	4 low-order bits at address 0000H in program memory are set in PC bits 11 to 8, and the data at address 0001H are set in PC bits 7 to 0.	
	μPD750006, 750008	5 low-order bits at address 0000H in program memory are set in PC bits 12 to 8, and the data at address 0001H are set in PC bits 7 to 0.	5 low-order bits at address 0000H in program memory are set in PC bits 12 to 8, and the data at address 0001H are set in PC bits 7 to 0.	
PSW	Carry flag (CY)	Held	Undefined	
	Skip flags (SK0 to SK2)	0	0	
	Interrupt status flags (IST0, IST1)	0	0	
	Bank enable flags (MBE, RBE)	Bit 6 at address 0000H in program memory is set in RBE, and bit 7 is set in MBE.	Bit 6 at address 0000H in program memory is set in RBE, and bit 7 is set in MBE.	
Stack pointer (SP)		Undefined	Undefined	
Stack bank selection register (SBS)		1000B	1000B	
★	Data memory (RAM)		Held	Undefined
General-purpose registers (X, A, H, L, D, E, B, C)		Held	Undefined	
Bank selection register (MBS, RBS)		0, 0	0, 0	
★	Basic interval timer/watchdog timer	Counter (BT)	Undefined	Undefined
		Mode register (BTM)	0	0
		Watchdog timer enable flag (WDTM)	0	0
Timer/event counter	Counter (T0)	0	0	
	Modulo register (TMOD0)	FFH	FFH	
	Mode register (TM0)	0	0	
	TOE0, TOUT flip-flop	0, 0	0, 0	
Timer counter	Counter (T1)	0	0	
	Modulo register (TMOD1)	FFH	FFH	
	Mode register (TM1)	0	0	
	TOE1, TOUT flip-flop	0, 0	0, 0	
Clock timer	Mode register (WM)	0	0	
Serial interface	Shift register (SIO)	Held	Undefined	
	Operation mode register (CSIM)	0	0	
	SBI control register (SBIC)	0	0	
	Slave address register (SVA)	Held	Undefined	

Table 9-1 Status of the Hardware after a Reset (2/2)

Hardware		Generation of a RESET signal in a standby mode	Generation of a RESET signal during operation
Clock generator, clock output circuit	Processor clock control register (PCC)	0	0
	System clock control register (SCC)	0	0
	Clock output mode register (CLOM)	0	0
Sub-oscillator control register (SOS)		0	0
Interrupt	Interrupt request flag (IRQ _{xxx})	Reset (0)	Reset (0)
	Interrupt enable flag (IE _{xxx})	0	0
	Priority selection register (IPS)	0	0
	INT0, INT1, and INT2 mode registers (IM0, IM1, IM2)	0, 0, 0	0, 0, 0
Digital ports	Output buffer	Off	Off
	Output latch	Clear (0)	Clear (0)
	I/O mode registers (PMGA, PMGB, PMGC)	0	0
	Pull-up resistor specification registers (POGA, POGB)	0	0
Bit sequential buffers (BSB0 to BSB3)		Held	Undefined

10. MASK OPTION

The μ PD750008 has the following mask options:

- Mask option of P40 to P43 and P50 to P53
Can specify whether to incorporate the pull-up resistor.
 - ① The pull-up resistor is incorporated bit by bit.
 - ② The pull-up resistor is not incorporated.

- Mask option of standby function
Can specify the wait time with the RESET signal.
 - ① $2^{17}/f_x$ (21.8 ms at $f_x = 6.0$ MHz, 31.3 ms at $f_x = 4.19$ MHz)
 - ② $2^{15}/f_x$ (5.46 ms at $f_x = 6.0$ MHz, 7.81 ms at $f_x = 4.19$ MHz)

- Mask option of subsystem clock
Can specify whether to enable the built-in feedback resistor.
 - ① The built-in feedback resistor is enabled (it is turned on or off by software).
 - ② The built-in feedback resistor is disabled (it is cut by hardware).

11. INSTRUCTION SET

(1) Operand identifier and its descriptive method

The operands are described in the operand column of each instruction according to the descriptive method for the operand format of the appropriate instructions. (For details, refer to *RA75X Assembler Package User's Manual: Language* (EEU-1363).) For descriptions in which alternatives exist, one element should be selected. Capital letters and plus and minus signs are keywords; therefore, they should be described as they are. For immediate data, the appropriate numerical values or labels should be described. The symbols of register flags can be used as a label instead of mem, fmem, pmem, and bit. (For details, refer to *μPD750008 User's Manual* (U10740E).) However, there are some restrictions on usable labels for fmem and pmem.



Representation format	Description
reg reg1	X, A, B, C, D, E, H, L X, B, C, D, E, H, L
rp rp1 rp2 rp' rp'1	XA, BC, DE, HL BC, DE, HL BC, DE XA, BC, DE, HL, XA', BC', DE', HL' BC, DE, HL, XA', BC', DE', HL'
rpa rpa1	HL, HL+, HL-, DE, DL DE, DL
n4 n8	4-bit immediate data or label 8-bit immediate data or label
mem bit	8-bit immediate data or label Note 2-bit immediate data or label
fmem pmem	FB0H - FBFH, FF0H - FFFH immediate data or label FC0H - FFFH immediate data or label
addr	0000H - 0FFFH immediate data or label (μPD750004) 0000H - 17FFH immediate data or label (μPD750006) 0000H - 1FFFH immediate data or label (μPD750008)
addr1(for Mk II mode only)	0000H - 0FFFH immediate data or label (μPD750004) 0000H - 17FFH immediate data or label (μPD750006) 0000H - 1FFFH immediate data or label (μPD750008)
caddr	12-bit immediate data or label
faddr	11-bit immediate data or label
taddr	20H - 7FH immediate data (however, bit 0 = 0) or label
PORTn IExxx RBn MBn	PORT0 - PORT8 IEBT, IET0, IET1, IE0 - IE2, IE4, IECSI, IEW RB0 - RB3 MB0, MB1, MB15

Note Only even address can be specified for 8-bit data processing.

(2) Symbol definitions in operation description

A	: A register; 4-bit accumulator
B	: B register
C	: C register
D	: D register
E	: E register
H	: H register
L	: L register
X	: X register
XA	: Register pair (XA); 8-bit accumulator
BC	: Register pair (BC)
DE	: Register pair (DE)
HL	: Register pair (HL)
XA'	: Extended register pair (XA')
BC'	: Extended register pair (BC')
DE'	: Extended register pair (DE')
HL'	: Extended register pair (HL')
PC	: Program counter
SP	: Stack pointer
CY	: Carry flag; Bit accumulator
PSW	: Program status word
MBE	: Memory bank enable flag
RBE	: Register bank enable flag
PORT _n	: Port n (n = 0 to 8)
IME	: Interrupt master enable flag
IPS	: Interrupt priority specification register
IE _{xxx}	: Interrupt enable flag
RBS	: Register bank selection register
MBS	: Memory bank selection register
PCC	: Processor clock control register
.	: Address bit delimiter
(xx)	: Contents addressed by xx
xxH	: Hexadecimal data

(3) Symbols used for the addressing area column

* 1	MB = MBE • MBS (MBS = 0, 1, 15)	 Data memory addressing
* 2	MB = 0	
* 3	MBE = 0: MB = 0 (000H - 07FH), MB = 15 (F80H - FFFH) MBE = 1: MB = MBS (MBS = 0, 1, 15)	
* 4	MB = 15, fmem = FB0H - FBFH, FF0H - FFFH	
* 5	MB = 15, pmem = FC0H - FFFH	
* 6	addr = 0000H - 0FFFH (μPD750004), 0000H - 17FFH (μPD750006) 0000H - 1FFFH (μPD750008)	 Program memory addressing
* 7	addr, addr1 = (Current PC) - 15 to (Current PC) - 1 (Current PC) + 2 to (Current PC) + 16	
* 8	caddr = 0000H - 0FFFH (μPD750004) 0000H - 0FFFH (PC ₁₂ = 0: μPD750006, 750008) 1000H - 17FFH (PC ₁₂ = 1: μPD750006) 1000H - 1FFFH (PC ₁₂ = 1: μPD750008)	
* 9	faddr = 0000H - 07FFH	
* 10	taddr = 0020H - 007FH	
* 11	Mk II mode only addr1 = 0000H - 0FFFH (μPD750004) 0000H - 17FFH (μPD750006) 0000H - 1FFFH (μPD750008)	

- Remarks 1.** MB indicates the memory bank that can be accessed.
2. For *2, MB = 0 regardless of MBE and MBS settings.
 3. For *4 and *5, MB = 15 regardless of MBE and MBS settings.
 4. For *6 to *11, each addressable area is indicated.

(4) Description of machine cycle column

S indicates the number of machine cycles necessary for skipping any skip instruction. The value of S changes as follows:

- When no skip is performed : S = 0
- When a 1-byte or 2-byte instruction is skipped: S = 1
- When a 3-byte instruction^{Note} is skipped : S = 2

Note 3-byte instruction: BR !addr, BRA !addr1, CALL !addr, and CALLA !addr1 instructions.

Caution The GETI instruction is skipped in one machine cycle.

One machine cycle is equal to one cycle (= t_{cy}) of the CPU clock (Φ), and four types of times are available for selection according to the PCC setting.

Group	Mnemonic	Operand	Bytes	Machining cycle	Operation	Addressing area	Skip condition	
Transfer	MOV	A, #n4	1	1	$A \leftarrow n4$		String A	
		reg1, #n4	2	2	$reg1 \leftarrow n4$			
		XA, #n8	2	2	$XA \leftarrow n8$		String A	
		HL, #n8	2	2	$HL \leftarrow n8$		String B	
		rp2, #n8	2	2	$rp2 \leftarrow n8$			
		A, @HL	1	1	$A \leftarrow (HL)$		*1	
		A, @HL+	1	2 + S	$A \leftarrow (HL)$, then $L \leftarrow L + 1$		*1	L = 0
		A, @HL-	1	2 + S	$A \leftarrow (HL)$, then $L \leftarrow L - 1$		*1	L = FH
		A, @rpa1	1	1	$A \leftarrow (rpa1)$		*2	
		XA, @HL	2	2	$XA \leftarrow (HL)$		*1	
		@HL, A	1	1	$(HL) \leftarrow A$		*1	
		@HL, XA	2	2	$(HL) \leftarrow XA$		*1	
		A, mem	2	2	$A \leftarrow (mem)$		*3	
		XA, mem	2	2	$XA \leftarrow (mem)$		*3	
		mem, A	2	2	$(mem) \leftarrow A$		*3	
		mem, XA	2	2	$(mem) \leftarrow XA$		*3	
		A, reg	2	2	$A \leftarrow reg$			
		XA, rp'	2	2	$XA \leftarrow rp'$			
		reg1, A	2	2	$reg1 \leftarrow A$			
		rp'1, XA	2	2	$rp'1 \leftarrow XA$			
	XCH	A, @HL	1	1	$A \leftrightarrow (HL)$		*1	
		A, @HL+	1	2 + S	$A \leftrightarrow (HL)$, then $L \leftarrow L + 1$		*1	L = 0
		A, @HL-	1	2 + S	$A \leftrightarrow (HL)$, then $L \leftarrow L - 1$		*1	L = FH
		A, @rpa1	1	1	$A \leftrightarrow (rpa1)$		*2	
		XA, @HL	2	2	$XA \leftrightarrow (HL)$		*1	
		A, mem	2	2	$A \leftrightarrow (mem)$		*3	
		XA, mem	2	2	$XA \leftrightarrow (mem)$		*3	
		A, reg1	1	1	$A \leftrightarrow reg1$			
	XA, rp'	2	2	$XA \leftrightarrow rp'$				
	Table reference	MOVT	XA, @PCDE	1	3	<ul style="list-style-type: none"> • μPD750004 $XA \leftarrow (PC_{11-8} + DE)_{ROM}$ 		
<ul style="list-style-type: none"> • μPD750006, 750008 $XA \leftarrow (PC_{12-8} + DE)_{ROM}$ 								
		XA, @PCXA	1	3	<ul style="list-style-type: none"> • μPD750004 $XA \leftarrow (PC_{11-8} + XA)_{ROM}$ 			
					<ul style="list-style-type: none"> • μPD750006, 750008 $XA \leftarrow (PC_{12-8} + XA)_{ROM}$ 			
					<ul style="list-style-type: none"> • μPD750004 $XA \leftarrow (BCDE)_{ROM}$ Note 			*6
	XA, @BCXA	1	3	<ul style="list-style-type: none"> • μPD750004 $XA \leftarrow (BCXA)_{ROM}$ Note 	*6			

Note Set register B to 0 in the μPD750004. Only the LSB is valid in register B in the μPD750006 and μPD750008.

Group	Mnemonic	Operand	Bytes	Machining cycle	Operation	Addressing area	Skip condition
Bit transfer	MOV1	CY, fmem.bit	2	2	$CY \leftarrow (\text{fmem.bit})$	*4	
		CY, pmem.@L	2	2	$CY \leftarrow (\text{pmem}_{7-2} + L_{3-2}.\text{bit}(L_{1-0}))$	*5	
		CY, @H+mem.bit	2	2	$CY \leftarrow (H + \text{mem}_{3-0}.\text{bit})$	*1	
		fmem.bit, CY	2	2	$(\text{fmem.bit}) \leftarrow CY$	*4	
		pmem.@L, CY	2	2	$(\text{pmem}_{7-2} + L_{3-2}.\text{bit}(L_{1-0})) \leftarrow CY$	*5	
		@H+mem.bit, CY	2	2	$(H + \text{mem}_{3-0}.\text{bit}) \leftarrow CY$	*1	
Arithmetic	ADDS	A, #n4	1	1 + S	$A \leftarrow A + n4$		carry
		XA, #n8	2	2 + S	$XA \leftarrow XA + n8$		carry
		A, @HL	1	1 + S	$A \leftarrow A + (HL)$	*1	carry
		XA, rp'	2	2 + S	$XA \leftarrow XA + rp'$		carry
		rp'1, XA	2	2 + S	$rp'1 \leftarrow rp'1 + XA$		carry
	ADDC	A, @HL	1	1	$A, CY \leftarrow A + (HL) + CY$	*1	
		XA, rp'	2	2	$XA, CY \leftarrow XA + rp' + CY$		
		rp'1, XA	2	2	$rp'1, CY \leftarrow rp'1 + XA + CY$		
	SUBS	A, @HL	1	1 + S	$A \leftarrow A - (HL)$	*1	borrow
		XA, rp'	2	2 + S	$XA \leftarrow XA - rp'$		borrow
		rp'1, XA	2	2 + S	$rp'1 \leftarrow rp'1 - XA$		borrow
	SUBC	A, @HL	1	1	$A, CY \leftarrow A - (HL) - CY$	*1	
		XA, rp'	2	2	$XA, CY \leftarrow XA - rp' - CY$		
		rp'1, XA	2	2	$rp'1, CY \leftarrow rp'1 - XA - CY$		
	AND	A, #n4	2	2	$A \leftarrow A \wedge n4$		
		A, @HL	1	1	$A \leftarrow A \wedge (HL)$	*1	
		XA, rp'	2	2	$XA \leftarrow XA \wedge rp'$		
		rp'1, XA	2	2	$rp'1 \leftarrow rp'1 \wedge XA$		
	OR	A, #n4	2	2	$A \leftarrow A \vee n4$		
		A, @HL	1	1	$A \leftarrow A \vee (HL)$	*1	
		XA, rp'	2	2	$XA \leftarrow XA \vee rp'$		
		rp'1, XA	2	2	$rp'1 \leftarrow rp'1 \vee XA$		
	XOR	A, #n4	2	2	$A \leftarrow A \nabla n4$		
		A, @HL	1	1	$A \leftarrow A \nabla (HL)$	*1	
XA, rp'		2	2	$XA \leftarrow XA \nabla rp'$			
rp'1, XA		2	2	$rp'1 \leftarrow rp'1 \nabla XA$			
Accumulator manipulation	RORC	A	1	1	$CY \leftarrow A_0, A_3 \leftarrow CY, A_{n-1} \leftarrow A_n$		
	NOT	A	2	2	$A \leftarrow \overline{A}$		
Increment/decrement	INCS	reg	1	1 + S	$\text{reg} \leftarrow \text{reg} + 1$		reg = 0
		rp1	1	1 + S	$rp1 \leftarrow rp1 + 1$		rp1 = 00H
		@HL	2	2 + S	$(HL) \leftarrow (HL) + 1$	*1	(HL) = 0
		mem	2	2 + S	$(\text{mem}) \leftarrow (\text{mem}) + 1$	*3	(mem) = 0
	DECS	reg	1	1 + S	$\text{reg} \leftarrow \text{reg} - 1$		reg = FH
		rp'	2	2 + S	$rp' \leftarrow rp' - 1$		rp' = FFH

Group	Mnemonic	Operand	Bytes	Machining cycle	Operation	Addressing area	Skip condition
Comparison	SKE	reg, #n4	2	2 + S	Skip if reg = n4		reg = n4
		@HL, #n4	2	2 + S	Skip if (HL) = n4	*1	(HL) = n4
		A, @HL	1	1 + S	Skip if A = (HL)	*1	A = (HL)
		XA, @HL	2	2 + S	Skip if XA = (HL)	*1	XA = (HL)
		A, reg	2	2 + S	Skip if A = reg		A = reg
		XA, rp'	2	2 + S	Skip if XA = rp'		XA = rp'
Carry flag manipulation	SET1	CY	1	1	$CY \leftarrow 1$		
	CLR1	CY	1	1	$CY \leftarrow 0$		
	SKT	CY	1	1 + S	Skip if CY = 1		CY = 1
	NOT1	CY	1	1	$CY \leftarrow \overline{CY}$		
Memory bit manipulation	SET1	mem.bit	2	2	$(\text{mem.bit}) \leftarrow 1$	*3	
		fmem.bit	2	2	$(\text{fmem.bit}) \leftarrow 1$	*4	
		pmem. @L	2	2	$(\text{pmem}_{7-2} + L_{3-2}.\text{bit}(L_{1-0})) \leftarrow 1$	*5	
		@H+mem.bit	2	2	$(H + \text{mem}_{3-0}.\text{bit}) \leftarrow 1$	*1	
	CLR1	mem.bit	2	2	$(\text{mem.bit}) \leftarrow 0$	*3	
		fmem.bit	2	2	$(\text{fmem.bit}) \leftarrow 0$	*4	
		pmem. @L	2	2	$(\text{pmem}_{7-2} + L_{3-2}.\text{bit}(L_{1-0})) \leftarrow 0$	*5	
		@H+mem.bit	2	2	$(H + \text{mem}_{3-0}.\text{bit}) \leftarrow 0$	*1	
	SKT	mem.bit	2	2 + S	Skip if (mem.bit) = 1	*3	(mem.bit) = 1
		fmem.bit	2	2 + S	Skip if (fmem.bit) = 1	*4	(fmem.bit) = 1
		pmem. @L	2	2 + S	Skip if $(\text{pmem}_{7-2} + L_{3-2}.\text{bit}(L_{1-0})) = 1$	*5	(pmem.@L) = 1
		@H+mem.bit	2	2 + S	Skip if $(H + \text{mem}_{3-0}.\text{bit}) = 1$	*1	(@H + mem.bit) = 1
	SKF	mem.bit	2	2 + S	Skip if (mem.bit) = 0	*3	(mem.bit) = 0
		fmem.bit	2	2 + S	Skip if (fmem.bit) = 0	*4	(fmem.bit) = 0
		pmem. @L	2	2 + S	Skip if $(\text{pmem}_{7-2} + L_{3-2}.\text{bit}(L_{1-0})) = 0$	*5	(pmem.@L) = 0
		@H+mem.bit	2	2 + S	Skip if $(H + \text{mem}_{3-0}.\text{bit}) = 0$	*1	(@H + mem.bit) = 0
	SKTCLR	fmem.bit	2	2 + S	Skip if (fmem.bit) = 1 and clear	*4	(fmem.bit) = 1
		pmem. @L	2	2 + S	Skip if $(\text{pmem}_{7-2} + L_{3-2}.\text{bit}(L_{1-0})) = 1$ and clear	*5	(pmem.@L) = 1
		@H+mem.bit	2	2 + S	Skip if $(H + \text{mem}_{3-0}.\text{bit}) = 1$ and clear	*1	(@H + mem.bit) = 1
	AND1	CY, fmem.bit	2	2	$CY \leftarrow CY \wedge (\text{fmem.bit})$	*4	
		CY, pmem. @L	2	2	$CY \leftarrow CY \wedge (\text{pmem}_{7-2} + L_{3-2}.\text{bit}(L_{1-0}))$	*5	
		CY, @H+mem.bit	2	2	$CY \leftarrow CY \wedge (H + \text{mem}_{3-0}.\text{bit})$	*1	
	OR1	CY, fmem.bit	2	2	$CY \leftarrow CY \vee (\text{fmem.bit})$	*4	
		CY, pmem. @L	2	2	$CY \leftarrow CY \vee (\text{pmem}_{7-2} + L_{3-2}.\text{bit}(L_{1-0}))$	*5	
		CY, @H+mem.bit	2	2	$CY \leftarrow CY \vee (H + \text{mem}_{3-0}.\text{bit})$	*1	
	XOR1	CY, fmem.bit	2	2	$CY \leftarrow CY \nabla (\text{fmem.bit})$	*4	
		CY, pmem. @L	2	2	$CY \leftarrow CY \nabla (\text{pmem}_{7-2} + L_{3-2}.\text{bit}(L_{1-0}))$	*5	
		CY, @H+mem.bit	2	2	$CY \leftarrow CY \nabla (H + \text{mem}_{3-0}.\text{bit})$	*1	

Group	Mnemonic	Operand	Bytes	Machining cycle	Operation	Addressing area	Skip condition	
Branch	BRNote	addr	-	-	<ul style="list-style-type: none"> • μPD750004 PC₁₁₋₀ ← addr [The assembler selects the most adequate instruction from BR !addr, BRCB !caddr, or BR \$addr.] • μPD750006, 750008 PC₁₂₋₀ ← addr [The assembler selects the most adequate instruction from BR !addr, BRCB !caddr, or BR \$addr.] 	*6		
		addr1	-	-	<ul style="list-style-type: none"> • μPD750004 PC₁₁₋₀ ← addr1 [The assembler selects the most adequate instruction from instructions below. • BR !addr • BRA !addr1 • BRCB !caddr • BR \$addr1] • μPD750006, 750008 PC₁₂₋₀ ← addr1 [The assembler selects the most adequate instruction from instructions below. • BR !addr • BRA !addr1 • BRCB !caddr • BR \$addr1] 	*11		
		!addr	3	3	<ul style="list-style-type: none"> • μPD750004 PC₁₁₋₀ ← addr • μPD750006, 750008 PC₁₂₋₀ ← addr 	*6		
		\$addr	1	2	<ul style="list-style-type: none"> • μPD750004 PC₁₁₋₀ ← addr • μPD750006, 750008 PC₁₂₋₀ ← addr 	*7		
		\$addr1	1	2	<ul style="list-style-type: none"> • μPD750004 PC₁₁₋₀ ← addr1 • μPD750006, 750008 PC₁₂₋₀ ← addr1 			

Note The shaded portion is supported in Mk II mode only. The other portions are supported in Mk I mode only.

Group	Mnemonic	Operand	Bytes	Machining cycle	Operation	Addressing area	Skip condition	
Branch	BR	PCDE	2	3	• μPD750004 PC ₁₁₋₀ ← PC ₁₁₋₈ + DE			
					• μPD750006, 750008 PC ₁₂₋₀ ← PC ₁₂₋₈ + DE			
		PCXA		2	3	• μPD750004 PC ₁₁₋₀ ← PC ₁₁₋₈ + XA		
						• μPD750006, 750008 PC ₁₂₋₀ ← PC ₁₂₋₈ + XA		
		BCDE		2	3	• μPD750004 PC ₁₁₋₀ ← BCDE ^{Note 1}	*6	
						• μPD750006, 750008 PC ₁₂₋₀ ← BCDE ^{Note 2}		
		BCXA		2	3	• μPD750004 PC ₁₁₋₀ ← BCXA ^{Note 1}	*6	
						• μPD750006, 750008 PC ₁₂₋₀ ← BCXA ^{Note 2}		
		BRA ^{Note 3}	!addr1	3	3	• μPD750004 PC ₁₁₋₀ ← addr1	*11	
						• μPD750006, 750008 PC ₁₂₋₀ ← addr1		
	BRCB	!caddr	2	2	• μPD750004 PC ₁₁₋₀ ← caddr ₁₁₋₀	*8		
					• μPD750006, 750008 PC ₁₂₋₀ ← PC ₁₂ + caddr ₁₁₋₀			
Subroutine stack control	CALLA ^{Note 3}	!addr1	3	3	• μPD750004 (SP - 2) ← x, x, MBE, RBE (SP - 6) (SP - 3) (SP - 4) ← PC ₁₁₋₀ (SP - 5) ← 0, 0, 0, 0 PC ₁₁₋₀ ← addr1, SP ← SP - 6	*11		
					• μPD750006, 750008 (SP - 2) ← x, x, MBE, RBE (SP - 6) (SP - 3) (SP - 4) ← PC ₁₁₋₀ (SP - 5) ← 0, 0, 0, PC ₁₂ PC ₁₂₋₀ ← addr1, SP ← SP - 6			

- Notes**
1. Set register B to 0.
 2. Only the LSB is valid in register B.
 3. The shaded portion is supported in Mk II mode only. The other portions are supported in Mk I mode only.

Group	Mnemonic	Operand	Bytes	Machining cycle	Operation	Addressing area	Skip condition
Subroutine stack control	CALL ^{Note}	laddr	3	3	<ul style="list-style-type: none"> • μPD750004 (SP - 3) ← MBE, RBE, 0, 0 (SP - 4) (SP - 1) (SP - 2) ← PC₁₁₋₀ PC₁₁₋₀ ← addr, SP ← SP - 4 	*6	
				3	<ul style="list-style-type: none"> • μPD750006, 750008 (SP - 3) ← MBE, RBE, 0, PC₁₂ (SP - 4) (SP - 1) (SP - 2) ← PC₁₁₋₀ PC₁₂₋₀ ← addr, SP ← SP - 4 		
			4	4	<ul style="list-style-type: none"> • μPD750004 (SP - 2) ← x, x, MBE, RBE (SP - 6) (SP - 3) (SP - 4) ← PC₁₁₋₀ (SP - 5) ← 0, 0, 0, 0 PC₁₁₋₀ ← addr, SP ← SP - 6 		
				4	<ul style="list-style-type: none"> • μPD750006, 750008 (SP - 2) ← x, x, MBE, RBE (SP - 6) (SP - 3) (SP - 4) ← PC₁₁₋₀ (SP - 5) ← 0, 0, 0, PC₁₂ PC₁₂₋₀ ← addr, SP ← SP - 6 		
	CALLF ^{Note}	lfaddr	2	2	<ul style="list-style-type: none"> • μPD750004 (SP - 3) ← MBE, RBE, 0, 0 (SP - 4) (SP - 1) (SP - 2) ← PC₁₁₋₀ PC₁₁₋₀ ← 0 + faddr, SP ← SP - 4 	*9	
				2	<ul style="list-style-type: none"> • μPD750006, 750008 (SP - 3) ← MBE, RBE, 0, PC₁₂ (SP - 4) (SP - 1) (SP - 2) ← PC₁₁₋₀ PC₁₂₋₀ ← 00 + faddr, SP ← SP - 4 		
			3	3	<ul style="list-style-type: none"> • μPD750004 (SP - 2) ← x, x, MBE, RBE (SP - 6) (SP - 3) (SP - 4) ← PC₁₁₋₀ (SP - 5) ← 0, 0, 0, 0 PC₁₁₋₀ ← 0 + faddr, SP ← SP - 6 		
				3	<ul style="list-style-type: none"> • μPD750006, 750008 (SP - 2) ← x, x, MBE, RBE (SP - 6) (SP - 3) (SP - 4) ← PC₁₁₋₀ (SP - 5) ← 0, 0, 0, PC₁₂ PC₁₂₋₀ ← 00 + faddr, SP ← SP - 6 		

Note The shaded portion is supported in Mk II mode only. The other portions are supported in Mk I mode only.

Group	Mnemonic	Operand	Bytes	Machining cycle	Operation	Addressing area	Skip condition
Subroutine stack control	RET ^{Note}		1	3	<ul style="list-style-type: none"> • μPD750004 PC₁₁₋₀ ← (SP) (SP + 3) (SP + 2) MBE, RBE, 0, 0 ← (SP + 1), SP ← SP + 4 • μPD750006, 750008 PC₁₁₋₀ ← (SP) (SP + 3) (SP + 2) MBE, RBE, 0, PC₁₂ ← (SP + 1) SP ← SP + 4 		
				3	<ul style="list-style-type: none"> • μPD750004 ×, ×, MBE, RBE ← (SP + 4) 0, 0, 0, 0 ← (SP + 1) PC₁₁₋₀ ← (SP) (SP + 3) (SP + 2) SP ← SP + 6 • μPD750006, 750008 ×, ×, MBE, RBE ← (SP + 4) MBE, 0, 0, PC₁₂ ← (SP + 1) PC₁₁₋₀ ← (SP) (SP + 3) (SP + 2) SP ← SP + 6 		
	RETS ^{Note}		1	3 + S	<ul style="list-style-type: none"> • μPD750004 MBE, RBE, 0, 0 ← (SP + 1) PC₁₁₋₀ ← (SP) (SP + 3) (SP + 2) SP ← SP + 4 then skip unconditionally • μPD750006, 750008 MBE, RBE, 0 ← PC₁₂ ← (SP + 1) PC₁₁₋₀ ← (SP) (SP + 3) (SP + 2) SP ← SP + 4 then skip unconditionally 		Uncondition
				3 + S	<ul style="list-style-type: none"> • μPD750004 0, 0, 0, 0 ← (SP + 1) PC₁₁₋₀ ← (SP) (SP + 3) (SP + 2) ×, ×, MBE, RBE ← (SP + 4) SP ← SP + 6 then skip unconditionally • μPD750006, 750008 0, 0, 0, PC₁₂ ← (SP + 1) PC₁₁₋₀ ← (SP) (SP + 3) (SP + 2) ×, ×, MBE, RBE ← (SP + 4) SP ← SP + 4 then skip unconditionally 		

Note The shaded portion is supported in Mk II mode only. The other portions are supported in Mk I mode only.

Group	Mnemonic	Operand	Bytes	Machining cycle	Operation	Addressing area	Skip condition	
Subroutine stack control	RET Note 1		1	3	<ul style="list-style-type: none"> • μPD750004 MBE, RBE, 0, 0 ← (SP + 1) PC₁₁₋₀ ← (SP) (SP + 3) (SP + 2) PSW ← (SP + 4) (SP + 5), SP ← SP + 6 • μPD750006, 750008 MBE, RBE, 0, PC₁₂ ← (SP + 1) PC₁₁₋₀ ← (SP) (SP + 3) (SP + 2) PSW ← (SP + 4) (SP + 5), SP ← SP + 6 • μPD750004 0, 0, 0, 0 ← (SP + 1) PC₁₁₋₀ ← (SP) (SP + 3) (SP + 2) PSW ← (SP + 4) (SP + 5), SP ← SP + 6 • μPD750006, 750008 0, 0, 0, PC₁₂ ← (SP + 1) PC₁₁₋₀ ← (SP) (SP + 3) (SP + 2) PSW ← (SP + 4) (SP + 5), SP ← SP + 6 			
		PUSH	rp	1	1	(SP - 1)(SP - 2) ← rp, SP ← SP - 2		
			BS	2	2	(SP - 1) ← MBS, (SP - 2) ← RBS, SP ← SP - 2		
		POP	rp	1	1	rp ← (SP + 1)(SP), SP ← SP + 2		
	BS		2	2	MBS ← (SP + 1), RBS ← (SP), SP ← SP + 2			
	Interrupt control	EI		2	2	IME (IPS.3) ← 1		
IE _{xxx}			2	2	IE _{xxx} ← 1			
DI			2	2	IME (IPS.3) ← 0			
		IE _{xxx}	2	2	IE _{xxx} ← 0			
Input/output	IN Note 2	A, PORT _n	2	2	A ← PORT _n (n = 0 - 8)			
		XA, PORT _n	2	2	XA ← PORT _{n+1} , PORT _n (n = 4, 6)			
	OUT Note 2	PORT _n , A	2	2	PORT _n ← A (n = 2 - 8)			
		PORT _n , XA	2	2	PORT _{n+1} , PORT _n ← XA (n = 4, 6)			
CPU control	HALT		2	2	Set HALT Mode (PCC.2 ← 1)			
	STOP		2	2	Set STOP Mode (PCC.3 ← 1)			
	NOP		1	1	No Operation			

Notes 1. The shaded portion is supported in Mk II mode only. The other portions are supported in Mk I mode only.

2. When executing the IN/OUT instruction, MBE must be set to 0 or MBE and MBS must be set to 1 and 15, respectively.

Group	Mnemonic	Operand	Bytes	Machining cycle	Operation	Addressing area	Skip condition
Special	SEL	Rn	2	2	$RBS \leftarrow n$ ($n = 0 - 3$)		
		Mn	2	2	$MBS \leftarrow n$ ($n = 0, 1, 15$)		
	GETI ^{Notes 1, 2}	taddr	1	3	<ul style="list-style-type: none"> • μPD750004 When the TBR instruction is used $PC_{11-0} \leftarrow (taddr)_{3-0} + (taddr + 1)$	*10	Depends on the referenced instruction.
					When the TCALL instruction is used $(SP - 4) (SP - 1) (SP - 2) \leftarrow PC_{11-0}$ $(SP - 3) \leftarrow MBE, RBE, 0, 0$ $PC_{11-0} \leftarrow (taddr)_{3-0} + (taddr + 1)$ $SP \leftarrow SP - 4$		
					When an instruction other than the TBR and TCALL instructions is used Execution of $(taddr)(taddr + 1)$ instruction		
					<ul style="list-style-type: none"> • μPD750006, 750008 When the TBR instruction is used $PC_{12-0} \leftarrow (taddr)_{4-0} + (taddr + 1)$		
				When the TCALL instruction is used $(SP - 4) (SP - 1) (SP - 2) \leftarrow PC_{11-0}$ $(SP - 3) \leftarrow MBE, RBE, 0, PC_{12}$ $PC_{12-0} \leftarrow (taddr)_{4-0} + (taddr + 1)$ $SP \leftarrow SP - 4$			
				When an instruction other than the TBR and TCALL instructions is used Execution of $(taddr)(taddr + 1)$ instruction		Depends on the referenced instruction.	
				<ul style="list-style-type: none"> • μPD750004 When the TBR instruction is used $PC_{11-0} \leftarrow (taddr)_{3-0} + (taddr + 1)$	*10		
			When the TCALL instruction is used $(SP - 6) (SP - 3) (SP - 4) \leftarrow PC_{11-0}$ $(SP - 5) \leftarrow 0, 0, 0, 0$ $(SP - 2) \leftarrow \times, \times, MBE, RBE$ $PC_{11-0} \leftarrow (taddr)_{3-0} + (taddr + 1)$ $SP \leftarrow SP - 6$				
			When an instruction other than the TBR and TCALL instructions is used Execution of $(taddr)(taddr + 1)$ instruction	Depends on the referenced instruction.			

Notes 1. The shaded portion is supported in Mk II mode only. The other portions are supported in Mk I mode only.
2. TBR and TCALL instructions are assembler pseudo instructions to define tables used for GETI instructions.

Group	Mnemonic	Operand	Bytes	Machining cycle	Operation	Addressing area	Skip condition
Special	GETI ^{Notes 1, 2}	taddr	1	3	<ul style="list-style-type: none"> • μPD750006, 750008 When the TBR instruction is used $PC_{12-0} \leftarrow (taddr)_{4-0} + (taddr + 1)$	*10	
				4	When the TCALL instruction is used $(SP - 6) (SP - 3) (SP - 4) \leftarrow PC_{11-0}$ $(SP - 5) \leftarrow 0, 0, 0, PC_{12}$ $(SP - 2) \leftarrow x, x, MBE, RBE$ $PC_{12-0} \leftarrow (taddr)_{4-0} + (taddr + 1)$ $SP \leftarrow SP - 6$		
				3	When an instruction other than the TBR and TCALL instructions is used Execution of $(taddr)(taddr + 1)$ instruction		

Notes 1. The shaded portion is supported in Mk II mode only.

2. TBR and TCALL instructions are assembler pseudo instructions to define tables used for GETI instructions.

12. ELECTRICAL CHARACTERISTICS

ABSOLUTE MAXIMUM RATINGS (T_A = 25 °C)

Parameter	Symbol	Conditions		Rated value	Unit
Supply voltage	V _{DD}			-0.3 to +7.0	V
Input voltage	V _{I1}	Other than ports 4 and 5		-0.3 to V _{DD} + 0.3	V
		Ports 4 and 5	With a built-in pull-up resistor	-0.3 to V _{DD} + 0.3	V
	With open drain		-0.3 to +14	V	
Output voltage	V _O			-0.3 to V _{DD} + 0.3	V
High-level output current	I _{OH}	Each pin		-10	mA
		Total of all pins		-30	mA
Low-level output current	I _{OL}	Each pin		30	mA
		Total of all pins		220	mA
Operating ambient temperature	T _A			-40 to +85	°C
Storage temperature	T _{stg}			-65 to +150	°C

Caution Absolute maximum ratings are rated values beyond which physical damage will be caused to the product; if the rated value of any of the parameters in the above table is exceeded, even momentarily, the quality of the product may deteriorate. Always use the product within its rated values.

CAPACITANCE (T_A = 25 °C, V_{DD} = 0 V)

Parameter	Symbol	Conditions	Min.	Typ.	Max.	Unit
Input capacitance	C _{IN}	f = 1 MHz 0 V for pins other than pins to be measured			15	pF
Output capacitance	C _{OUT}				15	pF
I/O capacitance	C _{IO}				15	pF

CHARACTERISTICS OF THE MAIN SYSTEM CLOCK OSCILLATOR (T_A = -40 to +85 °C)

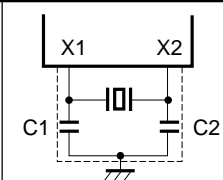
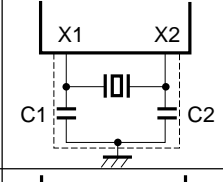
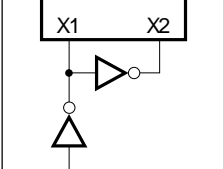
Resonator	Recommended constant	Parameter	Conditions	Min.	Typ.	Max.	Unit
Ceramic resonator		Oscillator frequency (f _x) ^{Note 1}	V _{DD} = 2.2 to 5.5 V	1.0		6.0 ^{Note 2}	MHz
		Oscillation settling time ^{Note 3}	After V _{DD} reaches Min. of the oscillation voltage range			4	ms
Crystal		Oscillator frequency (f _x) ^{Note 1}	V _{DD} = 2.2 to 5.5 V	1.0		6.0 ^{Note 2}	MHz
		Oscillation settling time ^{Note 3}	V _{DD} = 4.5 to 5.5 V			10	ms
			V _{DD} = 2.2 to 5.5 V			30	ms
External clock		X1 input frequency (f _x) ^{Note 1}	V _{DD} = 1.8 to 5.5 V	1.0		6.0 ^{Note 4}	MHz
		X1 input high/low level width (t _{xH} , t _{xL})	V _{DD} = 1.8 to 5.5 V	83.3		500	ns

Notes 1. The oscillator frequency and X1 input frequency indicate only the oscillator characteristics. See the item of AC characteristics for the instruction execution time.

- ★ **2.** When the supply voltage is 2.2 V ≤ V_{DD} < 2.7 V and the oscillator frequency is 4.7 MHz < f_x ≤ 6.0 MHz, set the processor clock control register (PCC) to a value other than 0011. When the PCC is set to 0011, the time for one machine cycle cannot satisfy the defined setting of 0.85 μs.
- 3.** The oscillation settling time means the time required for the oscillation to settle after V_{DD} is applied or after the STOP mode is released.
- ★ **4.** When the supply voltage is 1.8 V ≤ V_{DD} < 2.7 V and the X1 input frequency is 4.19 MHz < f_x ≤ 6.0 MHz, set the PCC to a value other than 0011. When the PCC is set to 0011, the time for one machine cycle cannot satisfy the defined setting of 0.95 μs.

Caution When the main system clock oscillator is used, conform to the following guidelines when wiring at the portions surrounded by dotted lines in the figures above to eliminate the influence of the wiring capacity.

- The wiring must be as short as possible.
- Other signal lines must not run in these areas.
- Any line carrying a high fluctuating current must be kept away as far as possible.
- The grounding point of the capacitor of the oscillator must have the same potential as that of V_{SS}.
- It must not be grounded to ground patterns carrying a large current.
- No signal must be taken from the oscillator.

CHARACTERISTICS OF THE SUBSYSTEM CLOCK OSCILLATOR (T_A = -40 to +85 °C)

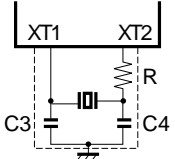
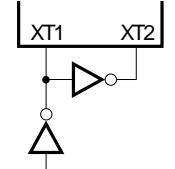
Resonator	Recommended constant	Parameter	Conditions	Min.	Typ.	Max.	Unit
Crystal		Oscillator frequency (f _{XT}) ^{Note 1}	V _{DD} = 2.2 to 5.5 V	32	32.768	35	kHz
		Oscillation settling time ^{Note 2}	V _{DD} = 4.5 to 5.5 V		1.0	2	s
			V _{DD} = 2.2 to 5.5 V				10
External clock		XT1 input frequency (f _{XT}) ^{Note 1}	V _{DD} = 1.8 to 5.5 V	32		100	kHz
		XT1 input high/low level width (t _{XTH} , t _{XTL})	V _{DD} = 1.8 to 5.5 V	5		15	μs

Notes 1. The oscillator frequency and input frequency indicate only the oscillator characteristics. See the item of AC characteristics for the instruction execution time.

2. The oscillation settling time means the time required for the oscillation to settle after V_{DD} is applied.

Caution When the subsystem clock oscillator is used, conform to the following guidelines when wiring at the portions of surrounded by dotted lines in the figures above to eliminate the influence of the wiring capacity.

- The wiring must be as short as possible.
- Other signal lines must not run in these areas.
- Any line carrying a high fluctuating current must be kept away as far as possible.
- The grounding point of the capacitor of the oscillator must have the same potential as that of V_{SS}
- It must not be grounded to ground patterns carrying a large current.
- No signal must be taken from the oscillator.

When the subsystem clock is used, pay special attention to its wiring; the subsystem clock oscillator has low amplification to minimize current consumption and is more likely to malfunction due to noise than the main system clock oscillator.

RECOMMENDED PARAMETERS FOR THE OSCILLATION CIRCUIT

When a ceramic resonator is used for the main system clock (T_A = -40 to +85 °C)

Manufacturer	Product name	Oscillation frequency (MHz)	Oscillation circuit constant		Oscillation voltage range		Remarks
			C1 (pF)	C2 (pF)	Min. (V)	Max. (V)	
Murata Mfg.	CSB1000J ^{Note}	1.0	100	100	2.8	5.5	Rd = 4.7 kΩ
	CSA2.00MG040	2.0	100	100	2.8		
	CST2.00MG040		Incorporated	Incorporated	2.8		
	CSA4.00MG	4.0	30	30	2.8		
	CST4.00MGW		Incorporated	Incorporated	2.8		
	CSA4.00MGU		30	30	2.6		
	CST4.00MGWU		Incorporated	Incorporated	2.6		
	CSA4.19MG	4.19	30	30	2.8		
	CST4.19MGW		Incorporated	Incorporated	2.8		
	CSA4.19MGU		30	30	2.8		
	CST4.19MGWU		Incorporated	Incorporated	2.8		
	CSA6.00MGU	6.0	30	30	2.9		
	CST6.00MGWU		Incorporated	Incorporated	2.9		
	CSA6.00MG		30	30	2.7		
CST6.00MGW	Incorporated		Incorporated	2.7			
Kyocera	KBR-1000F/Y	1.0	220	220	2.45	5.5	
	KBR-2.0MS	2.0	82	82	2.5		
	PBRC 2.00A		82	82	2.5		
	KBR-4.0MSA	4.0	33	33	2.5		
	KBR-4.0MKS		Incorporated	Incorporated	2.5		
	PBRC4.00A		33	33	2.5		
	PBRC4.00B		Incorporated	Incorporated	2.5		
	KBR-6.0MSA	6.0	33	33	2.5		
	KBR-6.0MKS		Incorporated	Incorporated	2.5		
	PBRC6.00A		33	33	2.5		
PBRC6.00B	Incorporated		Incorporated	2.5			
TDK	FCR2.0M3	2.0	33	33	2.2	5.5	
	FCR4.0M5	4.0	15	15	2.0		
	FCR4.19M5	4.19	15	15	2.2		
	FCR6.0M5	6.0	15	15	2.5		

Note When the CSB1000J (1.0 MHz) manufactured by Murata Mfg. is used, a limiting resistor (Rd = 4.7 kΩ) is necessary (see the following figure). When one of other resonators is used, no limiting resistor is required.

Recommended sample circuit for the main system clock when the CSB1000J manufactured by Murata Mfg. is used

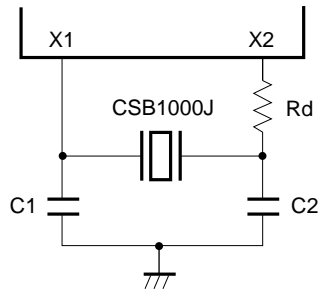

When a crystal is used for the subsystem clock (T_A = -10 to +60 °C)

Manufacturer	Product name	Oscillation frequency (kHz)	Oscillation circuit constant			Oscillation voltage range		Remarks
			C3 (pF)	C4 (pF)	R (kΩ)	Min. (V)	Max. (V)	
Daishinku	DT-38	32.768	10	10	220	2.7	5.5	Low-current-drain mode
						2.2	5.5	Low-voltage mode

Caution The oscillation circuit constant and oscillation voltage range indicate the conditions to settle the oscillation, not to guarantee the accuracy of the oscillation frequency. When an accuracy oscillation frequency is needed for the implemented circuit, the oscillation frequency of the resonator should be adjusted on the circuit. Ask the manufacturer of the resonator you use.

DC CHARACTERISTICS (T_A = -40 to +85 °C, V_{DD} = 2.2 to 5.5 V)

Parameter	Symbol	Conditions		Min.	Typ.	Max.	Unit	
Low-level output current	I _{OL}	Each pin				15	mA	
		Total of all pins				150	mA	
High-level input voltage	V _{IH1}	Ports 2, 3, and 8		2.7 V ≤ V _{DD} ≤ 5.5 V	0.7V _{DD}	V _{DD}	V	
				2.2 V ≤ V _{DD} < 2.7 V	0.9V _{DD}	V _{DD}	V	
	V _{IH2}	Ports 0, 1, 6, and 7 and $\overline{\text{RESET}}$		2.7 V ≤ V _{DD} ≤ 5.5 V	0.8V _{DD}	V _{DD}	V	
				2.2 V ≤ V _{DD} < 2.7 V	0.9V _{DD}	V _{DD}	V	
	V _{IH3}	Ports 4 and 5	With a Built-in pull-up resistor	2.7 V ≤ V _{DD} ≤ 5.5 V	0.7V _{DD}	V _{DD}	V	
				2.2 V ≤ V _{DD} < 2.7 V	0.9V _{DD}	V _{DD}	V	
			With N-ch open drain	2.7 V ≤ V _{DD} ≤ 5.5 V	0.7V _{DD}	13	V	
				2.2 V ≤ V _{DD} < 2.7 V	0.9V _{DD}	13	V	
V _{IH4}	X1, XT1		V _{DD} - 0.1		V _{DD}	V		
Low-level input voltage	V _{IL1}	Ports 2 to 5, and 8		2.7 V ≤ V _{DD} ≤ 5.5 V	0	0.3V _{DD}	V	
				2.2 V ≤ V _{DD} < 2.7 V	0	0.1V _{DD}	V	
	V _{IL2}	Ports 0, 1, 6, and 7 and $\overline{\text{RESET}}$		2.7 V ≤ V _{DD} ≤ 5.5 V	0	0.2V _{DD}	V	
				2.2 V ≤ V _{DD} < 2.7 V	0	0.1V _{DD}	V	
	V _{IL3}	X1, XT1		0		0.1	V	
High-level output voltage	V _{OH}	$\overline{\text{SCK}}$, SO, and ports 0, 2, 3, and 6 to 8 I _{OH} = -1.0 mA		V _{DD} - 0.5			V	
Low-level output voltage	V _{OL1}	$\overline{\text{SCK}}$, SO, and ports 2 to 8	I _{OL} = 15 mA, V _{DD} = 4.5 to 5.5 V		0.2	2.0	V	
			I _{OL} = 1.6 mA			0.4	V	
	V _{OL2}	SB0, SB1	N-ch open drain Pull-up resistor ≥ 1 kΩ			0.2V _{DD}	V	
High-level input leakage current	I _{LIH1}	V _{IN} = V _{DD}	Other than X1 and XT1			3	μA	
	I _{LIH2}		X1, XT1			20	μA	
	I _{LIH3}	V _{IN} = 13 V	Ports 4 and 5 (With N-ch open drain)			20	μA	
Low-level input leakage current	I _{LIL1}	V _{IN} = 0 V	Other than X1, XT1, and ports 4 and 5			-3	μA	
	I _{LIL2}		X1, XT1			-20	μA	
	I _{LIL3}		Ports 4 and 5 (With N-ch open drain) At other than input instruction execution			-3	μA	
			Ports 4 and 5 (With N-ch open drain) When the input instruction is executed	V _{DD} = 5.0 V		-10	-27	μA
				V _{DD} = 3.0 V		-3	-8	μA
High-level output leakage current	I _{LOH1}	V _{OUT} = V _{DD}	$\overline{\text{SCK}}$, SO/SB0, SB1, and ports 2, 3, and 6 to 8 Ports 4 and 5 (With a built-in pull-up resistor)			3	μA	
	I _{LOH2}	V _{OUT} = 13 V	Ports 4 and 5 (With N-ch open drain)			20	μA	
Low-level output leakage current	I _{LOL}	V _{OUT} = 0 V				-3	μA	
Built-in pull-up resistor	R _{L1}	V _{IN} = 0 V	Ports 0 to 3 and 6 to 8 (except P00 pin)	50	100	200	kΩ	
	R _{L2}		Ports 4 and 5 (mask option)	15	30	60	kΩ	

DC CHARACTERISTICS (T_A = -40 to +85 °C, V_{DD} = 2.2 to 5.5 V)

Parameter	Symbol	Conditions		Min.	Typ.	Max.	Unit		
Power supply current ^{Note 1}	I _{DD1}	6.0 MHz ^{Note 2} crystal	V _{DD} = 5.0 V ±10% ^{Note 3}			1.9	6.0	mA	
			V _{DD} = 3.0 V ±10% ^{Note 4}			0.4	1.3	mA	
	I _{DD2}	C1 = C2 = 22 pF	HALT mode	V _{DD} = 5.0 V ±10%			0.72	2.1	mA
				V _{DD} = 3.0 V ±10 %			0.27	0.8	mA
	I _{DD1}	4.19 MHz ^{Note 2} crystal	V _{DD} = 5.0 V ±10% ^{Note 3}			1.5	4.0	mA	
			V _{DD} = 3.0 V ±10% ^{Note 4}			0.25	0.75	mA	
	I _{DD2}	C1 = C2 = 22 pF	HALT mode	V _{DD} = 5.0 V ±10%			0.7	2.0	mA
				V _{DD} = 3.0 V ±10%			0.23	0.7	mA
	I _{DD3}	32.768 kHz ^{Note 5} crystal	Low-voltage mode ^{Note 6}	V _{DD} = 3.0 V ±10%			12	35	μA
				V _{DD} = 2.5 V ±10%			7	21	μA
				V _{DD} = 3.0 V, T _A = 25 °C			12	24	μA
			Low-current-drain mode ^{Note 7}	V _{DD} = 3.0 V ±10%			6	18	μA
				V _{DD} = 3.0 V, T _A = 25 °C			6	12	μA
			I _{DD4}	HALT mode	Low-voltage mode ^{Note 6}	V _{DD} = 3.0 V ±10%			8.5
	V _{DD} = 2.5 V ±10%						5	15	μA
V _{DD} = 3.0 V, T _A = 25 °C						8.5	17	μA	
Low-current-drain mode ^{Note 7}	V _{DD} = 3.0 V ±10%					3.5	12	μA	
	V _{DD} = 3.0 V, T _A = 25 °C			3.5	7	μA			
I _{DD5}	XT1 = 0 V ^{Note 8} STOP mode	V _{DD} = 5.0 V ±10%			0.05	10	μA		
		V _{DD} = 3.0 V ±10%			0.02	5	μA		
		T _A = 25 °C			0.02	3	μA		

- Notes**
1. This current excludes the current which flows through the built-in pull-up resistors.
 2. This value applies also when the subsystem clock oscillates.
 3. Value when the processor clock control register (PCC) is set to 0011 and the μPD750008 is operated in the high-speed mode.
 4. Value when the PCC is set to 0000 and the μPD750008 is operated in the low-speed mode.
 5. This value applies when the system clock control register (SCC) is set to 1001 to stop the main system clock pulse and to start the subsystem clock pulse.
 - ★ 6. Mode when the sub-oscillator control register (SOS) is set to 0000.
 - ★ 7. Mode when the SOS is set to 0010.
 - ★ 8. This value applies when the SOS is set to 00×1 and the sub-oscillator feedback resistor is not used (× = don't care).

AC CHARACTERISTICS (T_A = -40 to +85 °C, V_{DD} = 2.2 to 5.5 V)

Parameter	Symbol	Conditions		Min.	Typ.	Max.	Unit
★ CPU clock cycle time ^{Note 1} (minimum instruction execution time = 1 machine cycle)	t _{cy}	Operated by main system clock pulse	When ceramic or crystal is used	V _{DD} = 2.7 to 5.5 V	0.67	64	μs
					0.85	64	μs
			When external clock is used	V _{DD} = 2.7 to 5.5 V	0.67	64	μs
				V _{DD} = 1.8 to 5.5 V	0.95	64	μs
		Operated by subsystem clock pulse	114	122	125	μs	
★ T10 input frequency	f _{T1}	V _{DD} = 2.7 to 5.5 V		0		1.0	MHz
				0		275	kHz
T10 input high/low level width	t _{TIH} , t _{TIL}	V _{DD} = 2.7 to 5.5 V		0.48			μs
				1.8			μs
★ Interrupt input high/low level width	t _{INTH} , t _{INTL}	INT0	IM02 = 0	Note 2			μs
			IM02 = 1	10			μs
		INT1, INT2, and INT4		10			μs
		KR0 to KR7		10			μs
RESET low level width	t _{RSL}			10			μs

Notes 1. The cycle time of the CPU clock (Φ) (minimum instruction execution time) depends on the frequency of connected resonator (and external clock), the system clock control register (SCC), and the processor clock control register (PCC). The figure on the right side shows the cycle time t_{cy} characteristics for the supply voltage V_{DD} during main system clock operation.

2. This value becomes 2t_{cy} or 128/f_x according to the setting of the interrupt mode register (IM0).

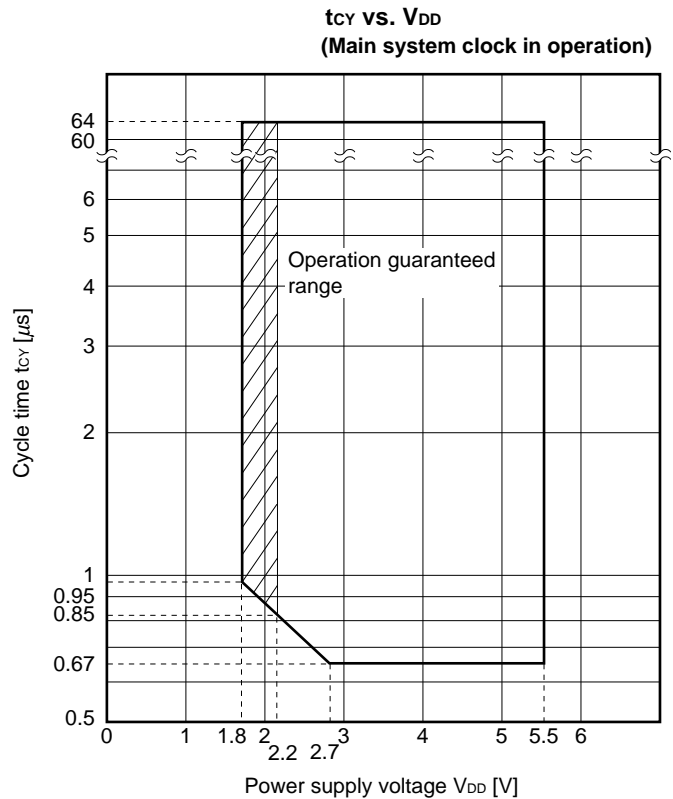

Remark The shaded portion is guaranteed only when the external clock is used.

SERIAL TRANSFER OPERATION

Two-wire and three-wire serial I/O modes ($\overline{\text{SCK}}$: Internal clock output): ($T_A = -40$ to $+85$ °C, $V_{DD} = 2.2$ to 5.5 V)

Parameter	Symbol	Conditions	Min.	Typ.	Max.	Unit
$\overline{\text{SCK}}$ cycle time	t_{KCY1}	$V_{DD} = 2.7$ to 5.5 V	1300			ns
			3800			ns
$\overline{\text{SCK}}$ high/low level width	$t_{\text{KL1}}, t_{\text{KH1}}$	$V_{DD} = 2.7$ to 5.5 V	$t_{\text{KCY1}}/2 - 50$			ns
			$t_{\text{KCY1}}/2 - 150$			ns
S ^{Note 1} setup time (referred to $\overline{\text{SCK}}\uparrow$)	t_{SIK1}	$V_{DD} = 2.7$ to 5.5 V	150			ns
			500			ns
S ^{Note 1} hold time (referred to $\overline{\text{SCK}}\uparrow$)	t_{KSI1}	$V_{DD} = 2.7$ to 5.5 V	400			ns
			600			ns
Delay time from $\overline{\text{SCK}}\downarrow$ to SO ^{Note 1} output	t_{KSO1}	$R_L = 1$ kΩ $C_L = 100$ pF ^{Note 2}	$V_{DD} = 2.7$ to 5.5 V		250	ns
					1000	ns

Notes 1. In two-wire serial I/O mode, SO should be read as SB0 or SB1.

2. R_L is the resistance of the SO output line load, while C_L is the capacitance.

Two-wire and three-wire serial I/O modes ($\overline{\text{SCK}}$: External clock input): ($T_A = -40$ to $+85$ °C, $V_{DD} = 2.2$ to 5.5 V)

Parameter	Symbol	Conditions	Min.	Typ.	Max.	Unit
$\overline{\text{SCK}}$ cycle time	t_{KCY2}	$V_{DD} = 2.7$ to 5.5 V	800			ns
			3200			ns
$\overline{\text{SCK}}$ high/low level width	$t_{\text{KL2}}, t_{\text{KH2}}$	$V_{DD} = 2.7$ to 5.5 V	400			ns
			1600			ns
S ^{Note 1} setup time (referred to $\overline{\text{SCK}}\uparrow$)	t_{SIK2}	$V_{DD} = 2.7$ to 5.5 V	100			ns
			150			ns
S ^{Note 1} hold time (referred to $\overline{\text{SCK}}\uparrow$)	t_{KSI2}	$V_{DD} = 2.7$ to 5.5 V	400			ns
			600			ns
Delay time from $\overline{\text{SCK}}\downarrow$ to SO ^{Note 1} output	t_{KSO2}	$R_L = 1$ kΩ $C_L = 100$ pF ^{Note 2}	$V_{DD} = 2.7$ to 5.5 V		300	ns
					1000	ns

Notes 1. In two-wire serial I/O mode, SO should be read as SB0 or SB1.

2. R_L is the resistance of the SO output line load, while C_L is the capacitance.

SBI mode ($\overline{\text{SCK}}$: Internal clock output (master)): ($T_A = -40$ to $+85$ °C, $V_{DD} = 2.2$ to 5.5 V)

Parameter	Symbol	Conditions		Min.	Typ.	Max.	Unit
$\overline{\text{SCK}}$ cycle time	t_{KCY3}	$V_{DD} = 2.7$ to 5.5 V		1300			ns
				3800			ns
$\overline{\text{SCK}}$ high/low level width	$t_{\text{KL3}}, t_{\text{KH3}}$	$V_{DD} = 2.7$ to 5.5 V		$t_{\text{KCY3}}/2 - 50$			ns
				$t_{\text{KCY3}}/2 - 150$			ns
SB0/SB1 setup time (referred to $\overline{\text{SCK}}\uparrow$)	t_{SIK3}	$V_{DD} = 2.7$ to 5.5 V		150			ns
				500			ns
SB0/SB1 hold time (referred to $\overline{\text{SCK}}\uparrow$)	t_{KSI3}			$t_{\text{KCY3}}/2$			ns
Delay time from $\overline{\text{SCK}}\downarrow$ to SB0/SB1 output	t_{KSO3}	$R_L = 1$ kΩ $C_L = 100$ pF ^{Note}	$V_{DD} = 2.7$ to 5.5 V	0		250	ns
				0		1000	ns
From $\overline{\text{SCK}}\uparrow$ to SB0/SB1↓	t_{KSB}			t_{KCY3}			ns
From SB0/SB1↓ to $\overline{\text{SCK}}\downarrow$	t_{SBK}			t_{KCY3}			ns
SB0/SB1 low level width	t_{SBL}			t_{KCY3}			ns
SB0/SB1 high level width	t_{SBH}			t_{KCY3}			ns

Note R_L is the resistance of the SB0/SB1 output line load, while C_L is the capacitance.

SBI mode ($\overline{\text{SCK}}$: External clock input (slave)): ($T_A = -40$ to $+85$ °C, $V_{DD} = 2.2$ to 5.5 V)

Parameter	Symbol	Conditions		Min.	Typ.	Max.	Unit
$\overline{\text{SCK}}$ cycle time	t_{KCY4}	$V_{DD} = 2.7$ to 5.5 V		800			ns
				3200			ns
$\overline{\text{SCK}}$ high/low level width	$t_{\text{KL4}}, t_{\text{KH4}}$	$V_{DD} = 2.7$ to 5.5 V		400			ns
				1600			ns
SB0/SB1 setup time (referred to $\overline{\text{SCK}}\uparrow$)	t_{SIK4}	$V_{DD} = 2.7$ to 5.5 V		100			ns
				150			ns
SB0/SB1 hold time (referred to $\overline{\text{SCK}}\uparrow$)	t_{KSI4}			$t_{\text{KCY4}}/2$			ns
Delay time from $\overline{\text{SCK}}\downarrow$ to SB0/SB1 output	t_{KSO4}	$R_L = 1$ kΩ $C_L = 100$ pF ^{Note}	$V_{DD} = 2.7$ to 5.5 V	0		300	ns
				0		1000	ns
From $\overline{\text{SCK}}\uparrow$ to SB0/SB1↓	t_{KSB}			t_{KCY4}			ns
From SB0/SB1↓ to $\overline{\text{SCK}}\downarrow$	t_{SBK}			t_{KCY4}			ns
SB0/SB1 low level width	t_{SBL}			t_{KCY4}			ns
SB0/SB1 high level width	t_{SBH}			t_{KCY4}			ns

Note R_L is the resistance of the SB0/SB1 output line load, while C_L is the capacitance.

★ AC timing measurement points (excluding X1 and XT1 inputs)

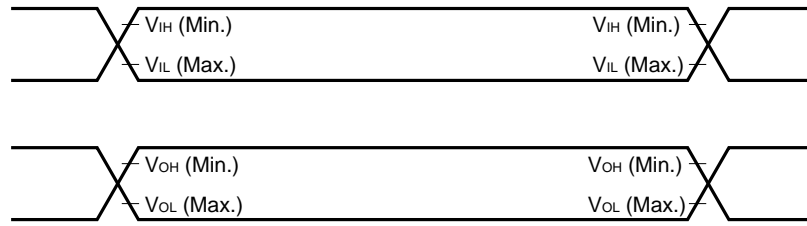

★ Clock timing

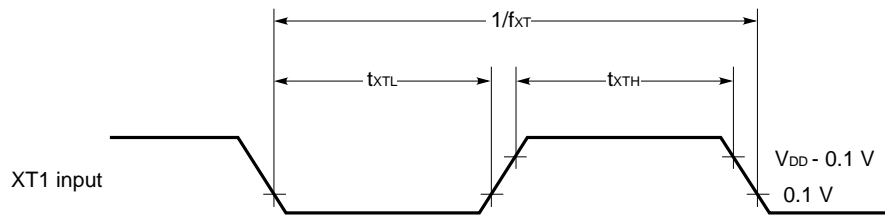
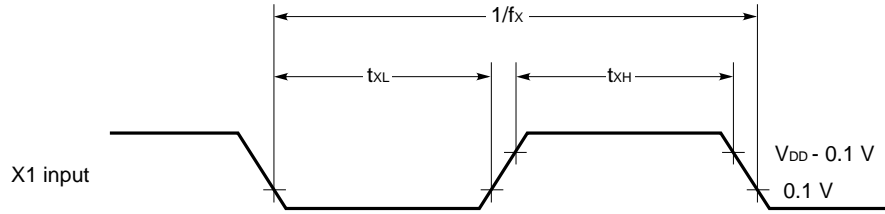

T10 timing

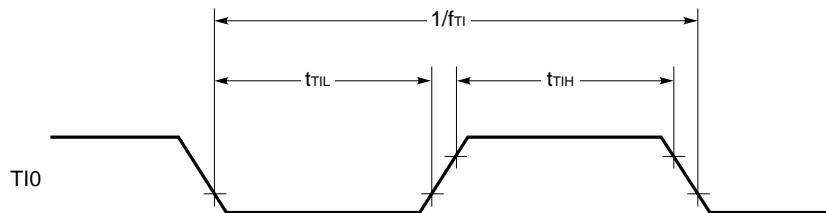

Serial transfer timing

Three-wire serial I/O mode:

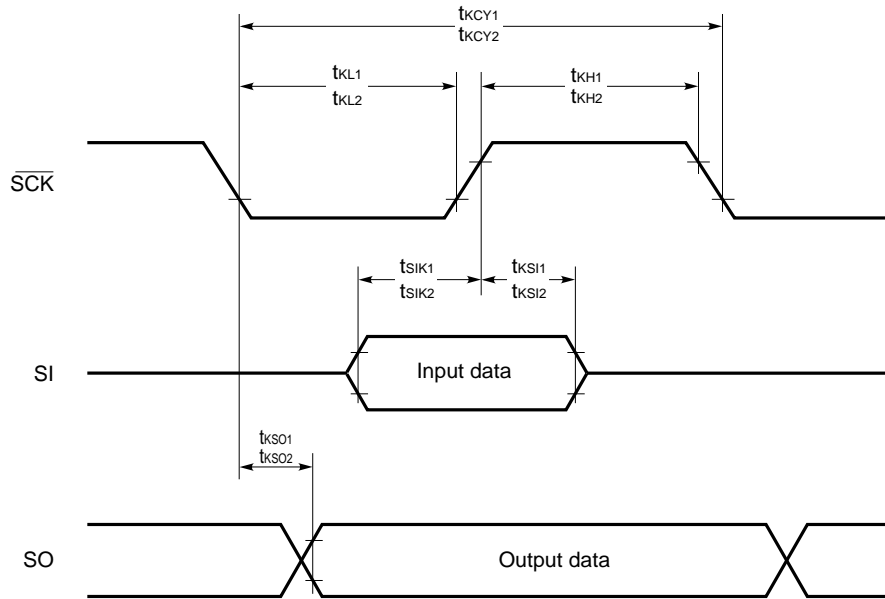

Two-wire serial I/O mode:

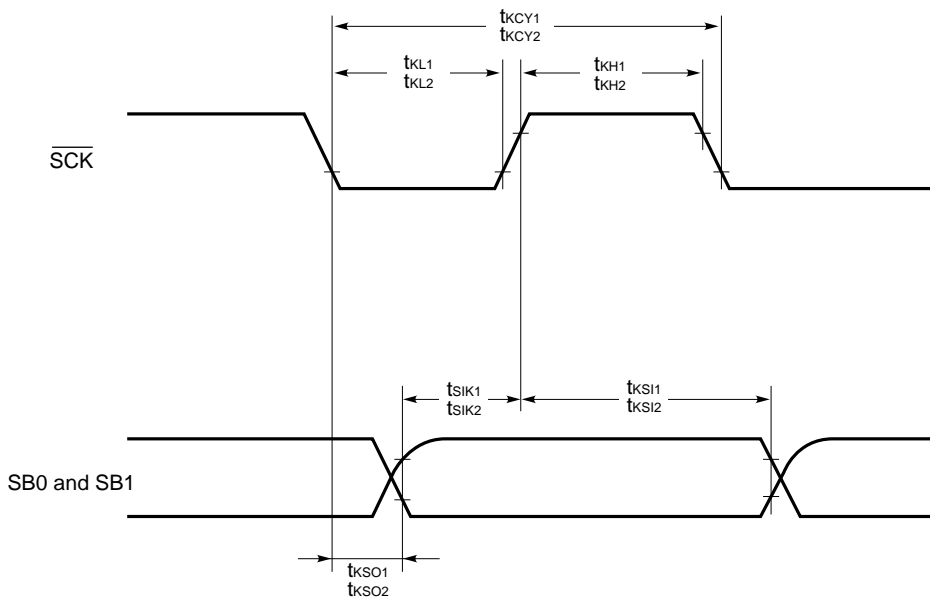

Serial transfer timing

Bus release signal transfer:

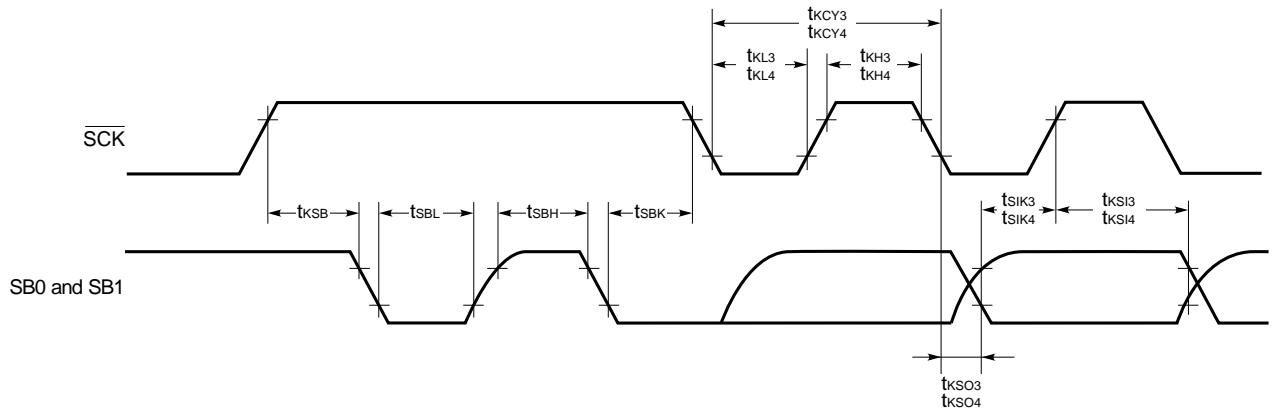

Command signal transfer:

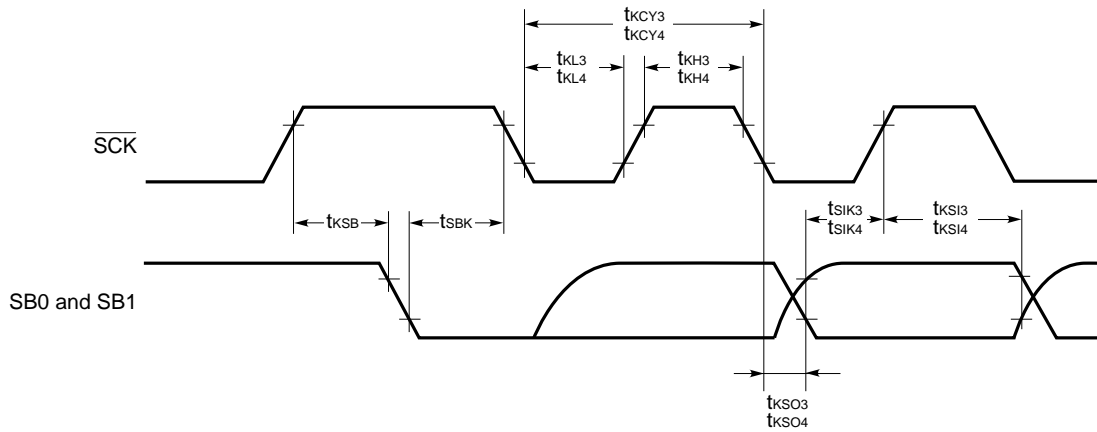

Interrupt input timing

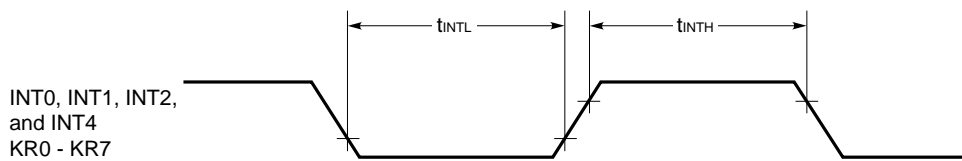

RESET input timing

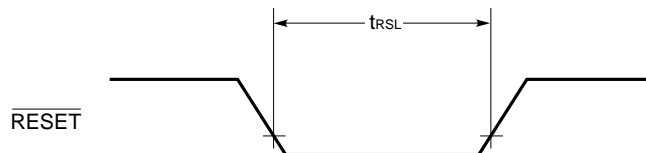

DATA HOLD CHARACTERISTICS BY LOW SUPPLY VOLTAGE IN DATA MEMORY STOP MODE
 (T_A = -40 to +85 °C)

Parameter	Symbol	Conditions	Min.	Typ.	Max.	Unit
Release signal setting time	t _{SREL}		0			μs
Oscillation settling time ^{Note 1}	t _{WAIT}	Release by $\overline{\text{RESET}}$		Note 2		ms
		Release by interrupt request		Note 3		ms

- Notes 1.** CPU operation stop time for preventing unstable operation at the beginning of oscillation.
2. Select either 2¹⁷/f_x or 2¹⁵/f_x with the mask option.
3. This value depends on the settings of the basic interval timer mode register (BTM) shown below.

BTM3	BTM2	BTM1	BTM0	Wait time	
				At f _x = 4.19 MHz	At f _x = 6.0 MHz
-	0	0	0	2 ²⁰ /f _x (approx. 250 ms)	2 ²⁰ /f _x (approx. 175 ms)
-	0	1	1	2 ¹⁷ /f _x (approx. 31.3 ms)	2 ¹⁷ /f _x (approx. 21.8 ms)
-	1	0	1	2 ¹⁵ /f _x (approx. 7.81 ms)	2 ¹⁵ /f _x (approx. 5.46 ms)
-	1	1	1	2 ¹³ /f _x (approx. 1.95 ms)	2 ¹³ /f _x (approx. 1.37 ms)

Data hold timing (STOP mode release by $\overline{\text{RESET}}$)

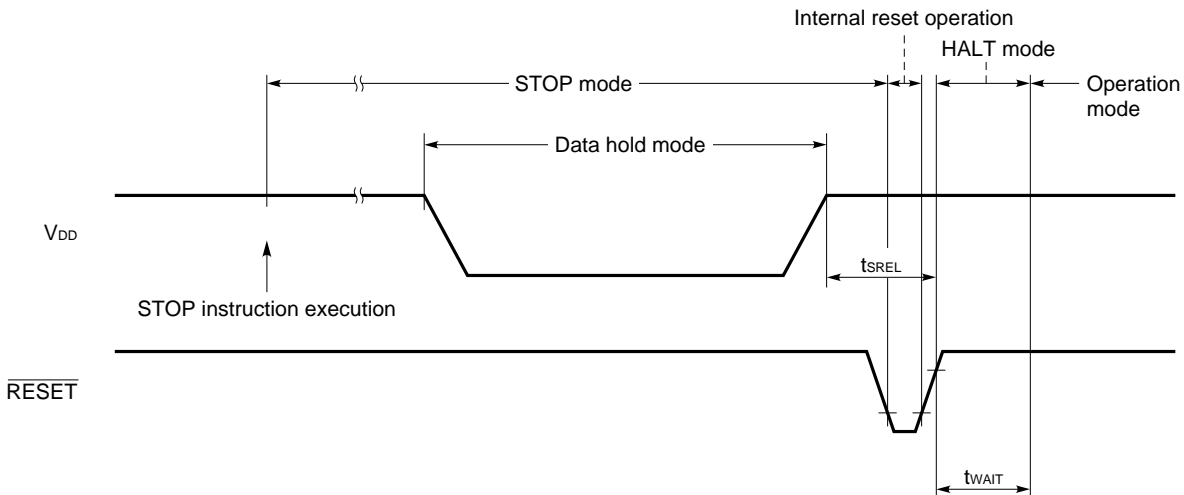

Data hold timing (standby release signal: STOP mode release by interrupt signal)

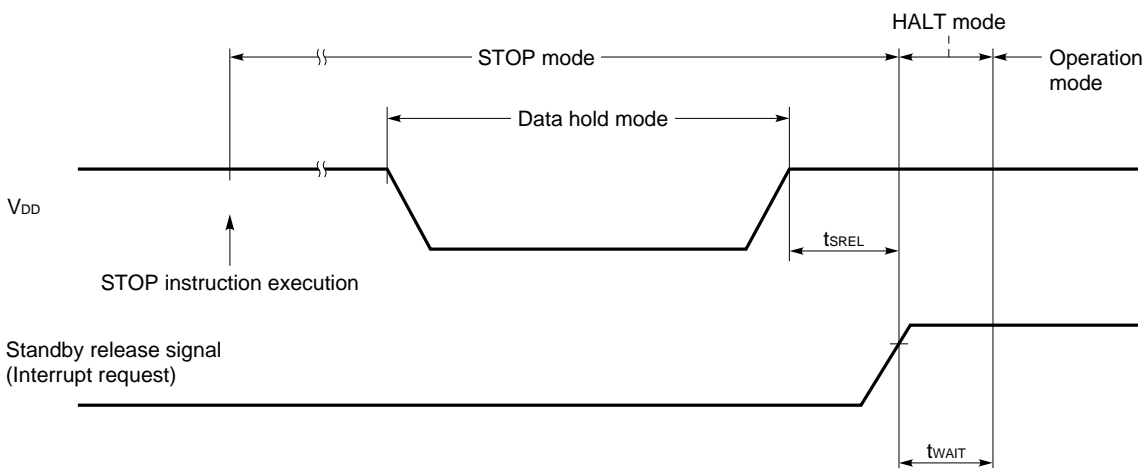

13. CHARACTERISTIC CURVE (REFERENCE VALUES)

I_{DD} vs. V_{DD} (When the main system clock is operating at 6.0 MHz with a crystal)

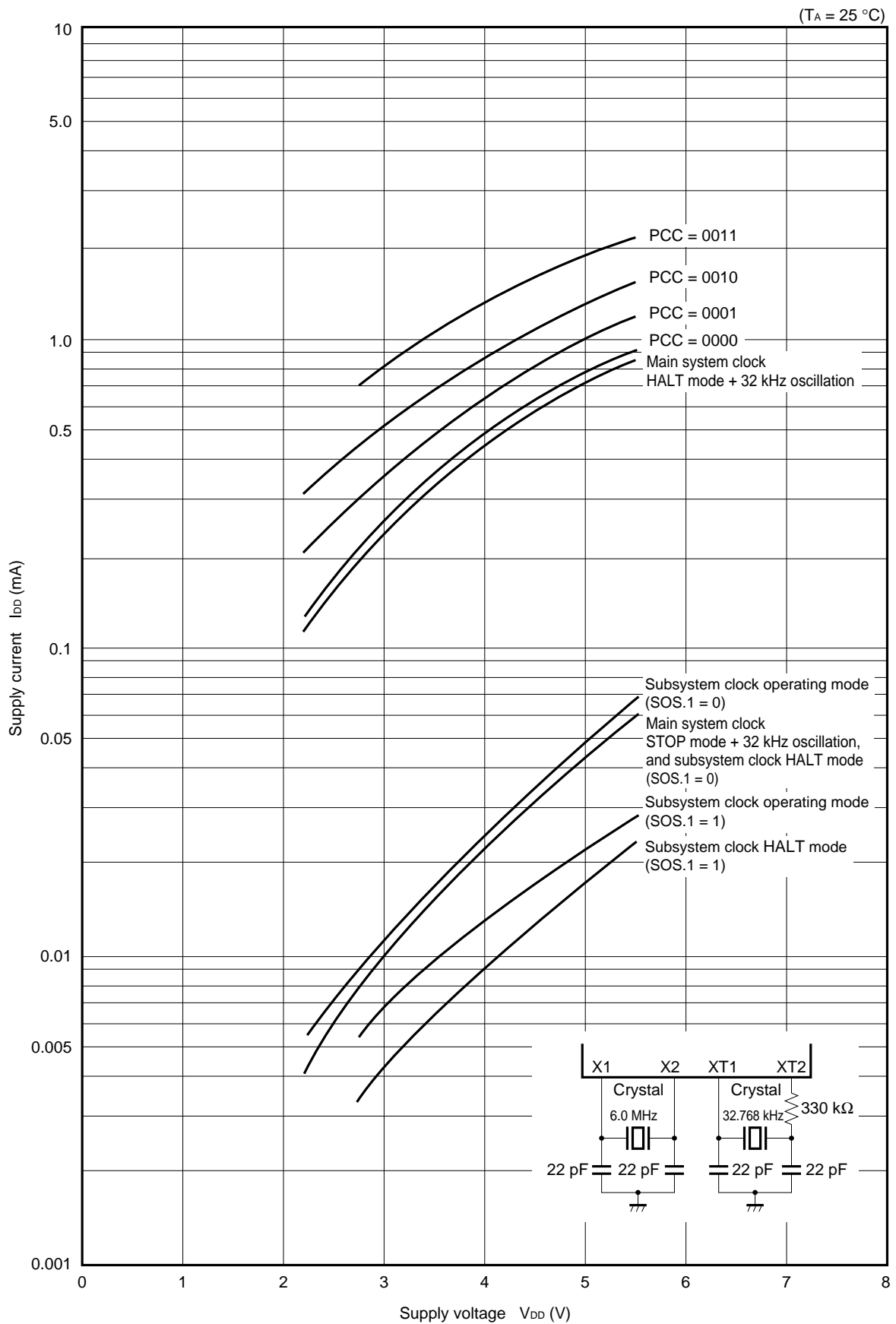

I_{DD} vs. V_{DD} (When the main system clock is operating at 4.19 MHz with a crystal)

(T_A = 25 °C)

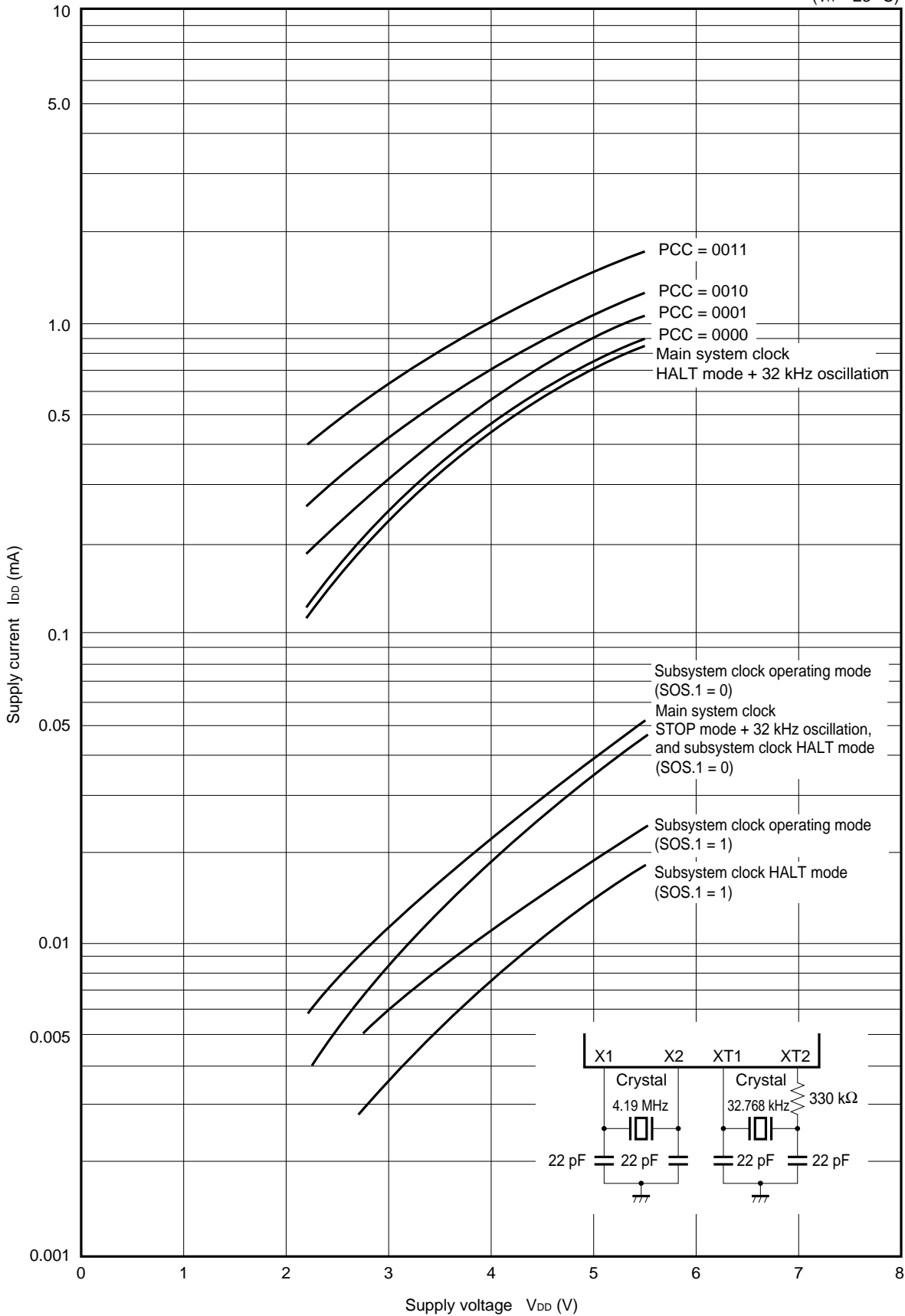

I_{OH} vs. $V_{DD} - V_{OH}$ (Ports 2, 3, 6, 7, and 8)

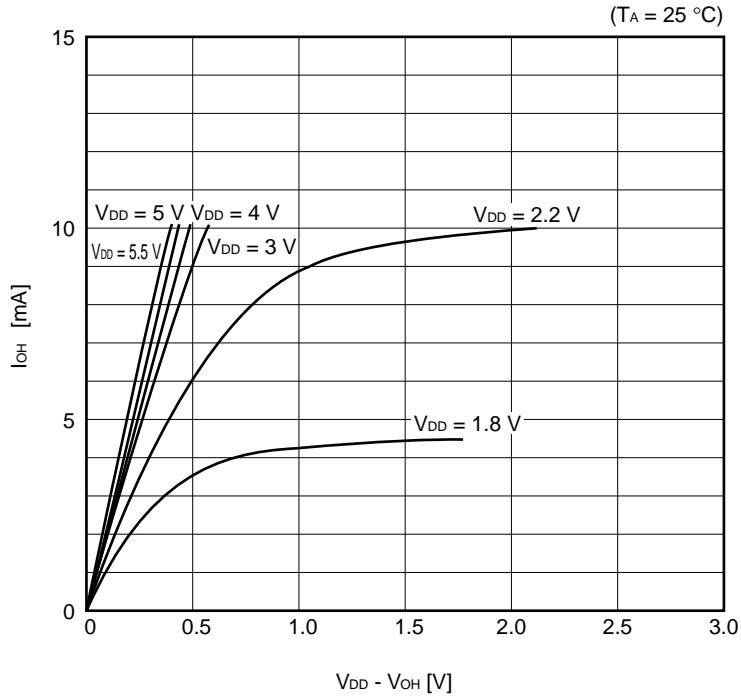

I_{OL} vs. V_{OL} (Ports 2, 3, 6, 7, and 8)

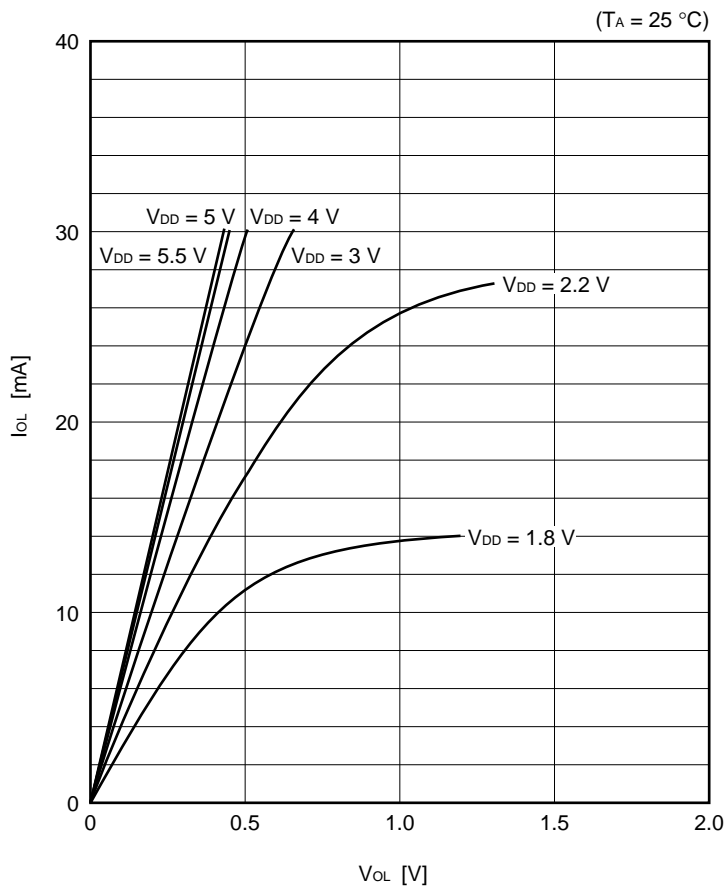

14. PACKAGE DRAWINGS

Package drawings of mass-produced products (1/2)

44 PIN PLASTIC QFP (□10)

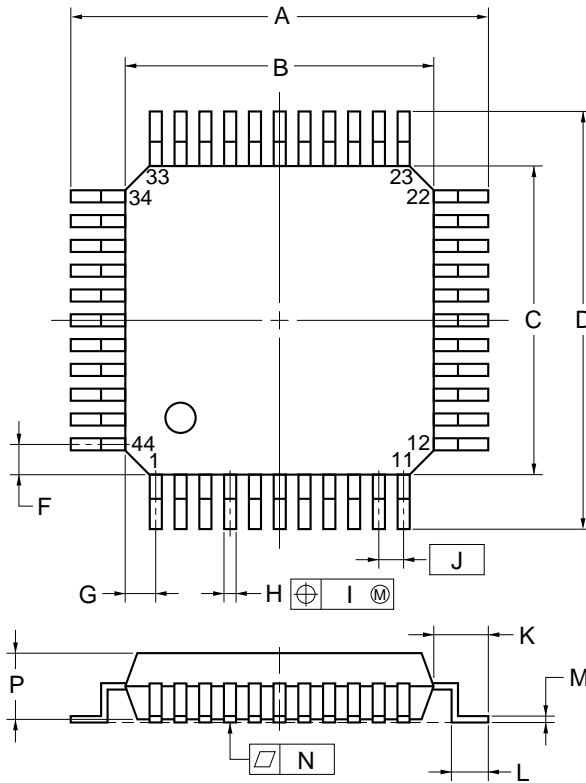

NOTE
Each lead centerline is located within 0.16 mm (0.007 inch) of its true position (T.P.) at maximum material condition.

ITEM	MILLIMETERS	INCHES
A	13.2±0.2	0.520 ^{+0.008} _{-0.009}
B	10.0±0.2	0.394 ^{+0.008} _{-0.009}
C	10.0±0.2	0.394 ^{+0.008} _{-0.009}
D	13.2±0.2	0.520 ^{+0.008} _{-0.009}
F	1.0	0.039
G	1.0	0.039
H	0.37 ^{+0.08} _{-0.07}	0.015 ^{+0.003} _{-0.004}
I	0.16	0.007
J	0.8 (T.P.)	0.031 (T.P.)
K	1.6±0.2	0.063±0.008
L	0.8±0.2	0.031 ^{+0.009} _{-0.008}
M	0.17 ^{+0.06} _{-0.05}	0.007 ^{+0.002} _{-0.003}
N	0.10	0.004
P	2.7	0.106
Q	0.125±0.075	0.005±0.003
R	3° ^{+7°} _{-3°}	3° ^{+7°} _{-3°}
S	3.0 MAX.	0.119 MAX.

S44GB-80-3BS

Caution The ES version is different from the corresponding mass-produced products in shape and material. See "ES package drawings."

Package drawings of mass-produced products (2/2)

42PIN PLASTIC SHRINK DIP (600 mil)

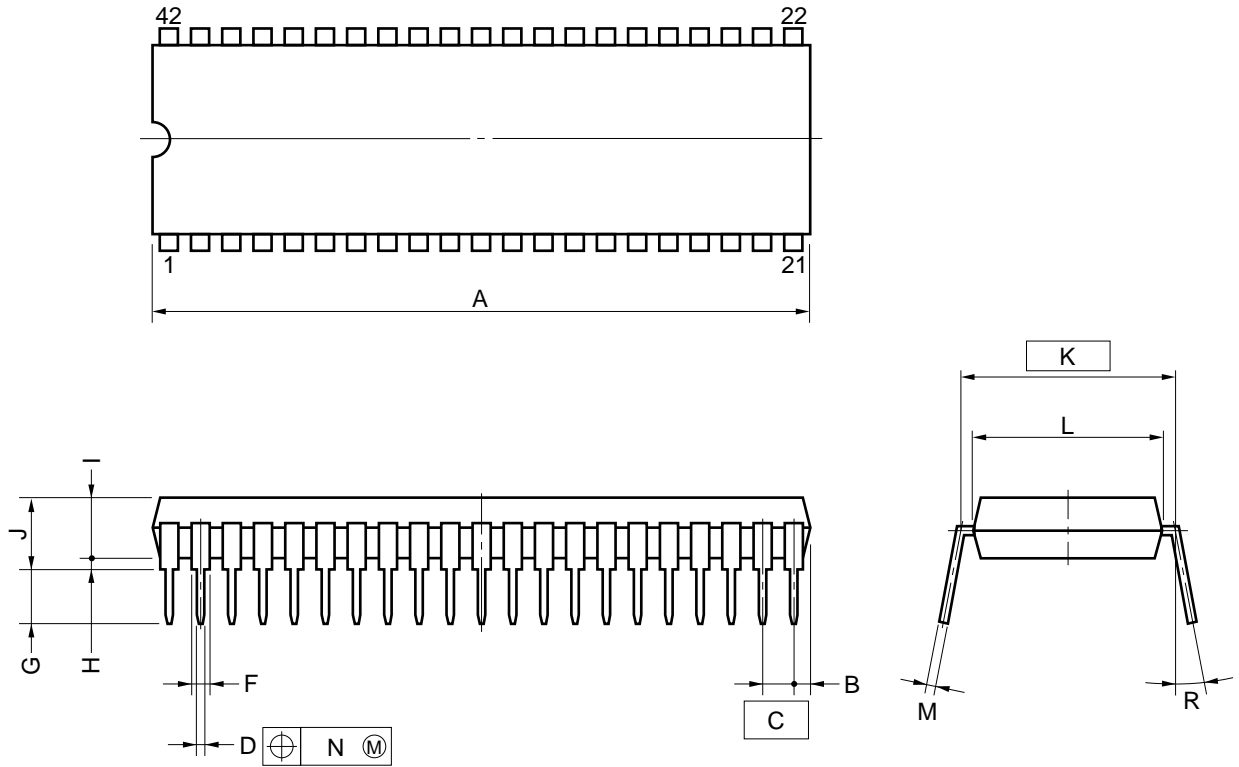

NOTES

- 1) Each lead centerline is located within 0.17 mm (0.007 inch) of its true position (T.P.) at maximum material condition.
- 2) Item "K" to center of leads when formed parallel.

ITEM	MILLIMETERS	INCHES
A	39.13 MAX.	1.541 MAX.
B	1.78 MAX.	0.070 MAX.
C	1.778 (T.P.)	0.070 (T.P.)
D	0.50±0.10	0.020 ^{+0.004} _{-0.005}
F	0.9 MIN.	0.035 MIN.
G	3.2±0.3	0.126±0.012
H	0.51 MIN.	0.020 MIN.
I	4.31 MAX.	0.170 MAX.
J	5.08 MAX.	0.200 MAX.
K	15.24 (T.P.)	0.600 (T.P.)
L	13.2	0.520
M	0.25 ^{+0.10} _{-0.05}	0.010 ^{+0.004} _{-0.003}
N	0.17	0.007
R	0~15°	0~15°

P42C-70-600A-1

Caution The shape and material of the ES version are the same as those of the corresponding mass-produced products.

ES package drawing

44 PIN CERAMIC QFP FOR ES (REFERENCE)

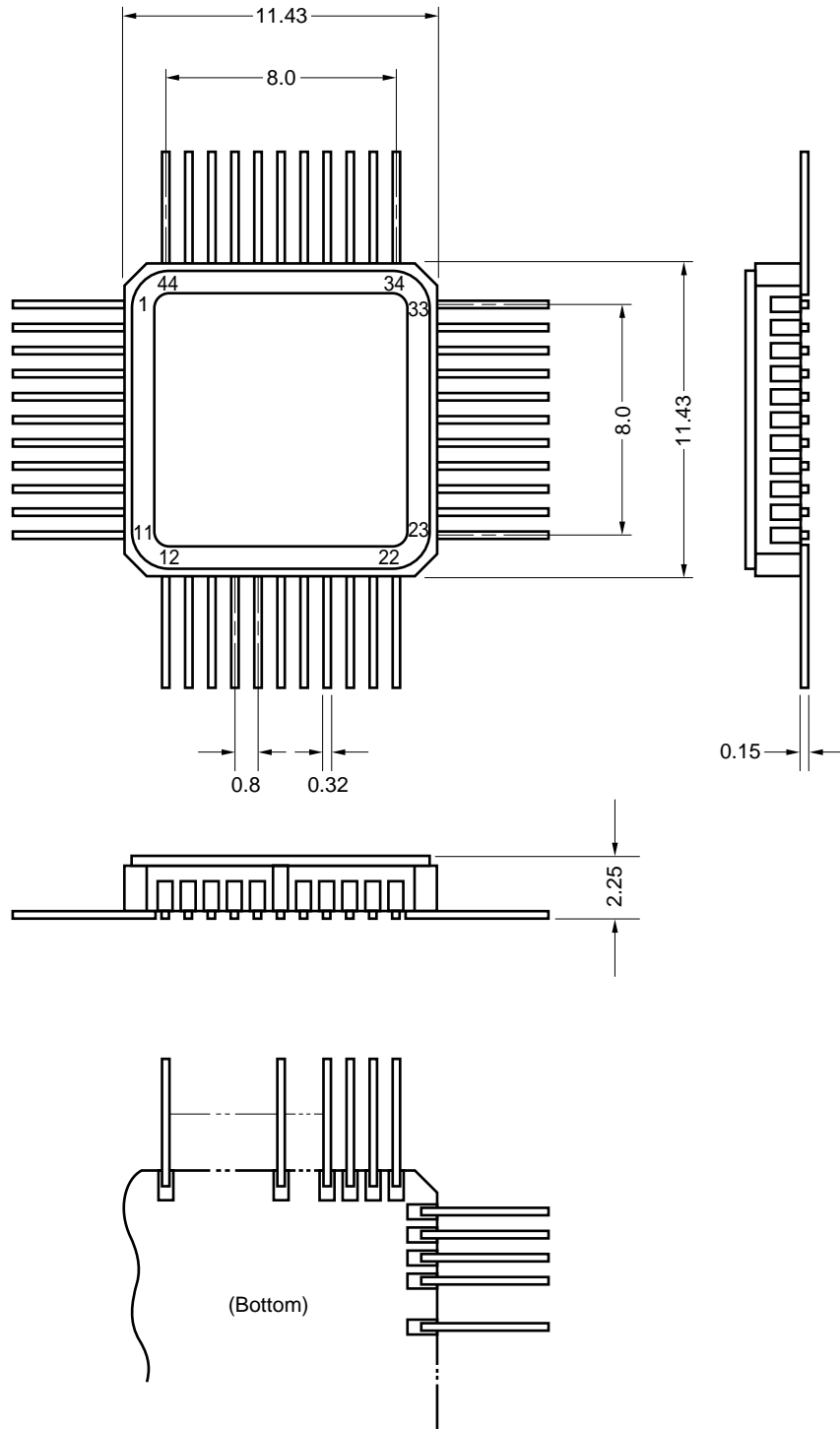

- Cautions**
1. Find the location of pin 1 by checking the location of pin 17, which is connected to the metal cap.
 2. The metal cap is connected to pin 17. The electrical level of the metal cap is V_{SS} (GND).
 3. The lead length has not been specified because leads are cut without any detailed specifications.

15. RECOMMENDED SOLDERING CONDITIONS

The μPD750004, μPD750006, and μPD750008 should be soldered and mounted under the conditions recommended in the table below.

For detail of recommended soldering conditions, refer to the information document *SMD Surface Mount Technology Manual* (C10535E).

For soldering methods and conditions other than those recommended below, contact our sales personnel.

Table 15-1 Surface Mounting Type Soldering Conditions

- μPD750004GB-xxx-3BS-MTX : 44-pin plastic QFP (10 × 10 mm, 0.8 mm pitch)
- μPD750006GB-xxx-3BS-MTX : 44-pin plastic QFP (10 × 10 mm, 0.8 mm pitch)
- μPD750008GB-xxx-3BS-MTX : 44-pin plastic QFP (10 × 10 mm, 0.8 mm pitch)
- μPD750004GB(A)-xxx-3BS-MTX : 44-pin plastic QFP (10 × 10 mm, 0.8 mm pitch)
- μPD750006GB(A)-xxx-3BS-MTX : 44-pin plastic QFP (10 × 10 mm, 0.8 mm pitch)
- μPD750008GB(A)-xxx-3BS-MTX : 44-pin plastic QFP (10 × 10 mm, 0.8 mm pitch)

Soldering method	Soldering conditions	Symbol
Infrared reflow	Package peak temperature: 235 °C Duration: 30 seconds max. (at 210 °C or above) Maximum allowable number of reflow processes: 3	IR35-00-3
VPS	Package peak temperature: 215 °C Duration: 40 seconds max. (at 200 °C or above) Maximum allowable number of reflow processes: 3	VP15-00-3
Wave soldering	Solder bath temperature: 260 °C max. Duration: 10 seconds max. Number of times: 1 Preliminary heat temperature: 120 °C max. (package surface temperature)	WS60-00-1
Partial heating method	Terminal temperature: 300 °C max. Duration: 3 seconds max. (per device side)	-

Caution Use of more than one soldering method should be avoided (except for partial heating method).

Table 15-2 Insertion Type Soldering Conditions

- μPD750004CU-xxx : 42-pin plastic shrink DIP (600 mil, 1.778 mm pitch)
- μPD750006CU-xxx : 42-pin plastic shrink DIP (600 mil, 1.778 mm pitch)
- μPD750008CU-xxx : 42-pin plastic shrink DIP (600 mil, 1.778 mm pitch)
- μPD750004CU(A)-xxx : 42-pin plastic shrink DIP (600 mil, 1.778 mm pitch)
- μPD750006CU(A)-xxx : 42-pin plastic shrink DIP (600 mil, 1.778 mm pitch)
- μPD750008CU(A)-xxx : 42-pin plastic shrink DIP (600 mil, 1.778 mm pitch)

Soldering method	Soldering conditions
Wave soldering (terminal only)	Solder bath temperature: 260 °C max., Duration: 10 seconds max.
Partial heating method	Terminal temperature: 300 °C max., Duration: 3 seconds max. (for each pin)

Caution Apply wave soldering to terminals only. See to it that the jet solder does not contact with the chip directly.

APPENDIX A FUNCTIONS OF THE μPD75008, μPD750008, AND μPD75P0016

(1/2)

Item		μPD75008	μPD750008	μPD75P0016
Program memory		Masked ROM 0000H - 1F7FH (8064 × 8 bits)	Masked ROM 0000H - 1FFFH (8192 × 8 bits)	One-time PROM 0000H - 3FFFH (16384 × 8 bits)
Data memory		000H - 1FFH (512 × 4 bits)		
CPU		75X standard CPU	75XL CPU	
General-purpose register		4 bits × 8 or 8 bits × 4	(4 bits × 8 or 8 bit × 4) × 4 banks	
Instruction execution time	When selecting the main system clock	• 0.95, 1.91, 15.3 μs (when operating at 4.19 MHz)	• 0.95, 1.91, 3.81, 15.3 μs (when operating at 4.19 MHz) • 0.67, 1.33, 2.67, 10.7 μs (when operating at 6.0 MHz)	
	When selecting the subsystem clock	122 μs (when operating at 32.768 kHz)		
Stack	SBS register	Not provided	Provided	SBS.3 = 1: Mk I mode selection SBS.3 = 0: Mk II mode selection
	Stack area	000H - 0FFH	n00H - nFFH (n = 0, 1)	
	Stack operation for a subroutine call instruction	2-byte stack	Mk I mode: 2-byte stack Mk II mode: 3-byte stack	
Instruction	BRA !addr1 CALLA !addr1	Not available	Mk I mode: Not available Mk II mode: Available	
	MOVT XA, @BCDE MOVT XA, @BCXA BR BCDE BR BCXA		Available	
	CALL !addr	3 machine cycles	Mk I mode: 3 machine cycles Mk II mode: 4 machine cycles	
	CALLF !faddr	2 machine cycles	Mk I mode: 2 machine cycles Mk II mode: 3 machine cycles	
Timer		3 channels • Basic interval timer: 1 channel • 8-bit timer/event counter: 1 channel • Clock timer: 1 channel	4 channels • Basic interval timer/watchdog timer: 1 channel • 8-bit timer/event counter: 1 channel • 8-bit timer counter: 1 channel • Clock timer: 1 channel	
Clock output (PCL)		• Φ, 524, 262, 65.5 kHz (when the main system clock operates at 4.19 MHz)	• Φ, 524, 262, 65.5 kHz (when the main system clock operates at 4.19 MHz) • Φ, 750, 375, 93.8 kHz (when the main system clock operates at 6.0 MHz)	
BUZ output (BUZ)		• 2 kHz	• 2, 4, 32 kHz (when the main system clock operates at 4.19 MHz) • 2.93, 5.86, 46.9 kHz (when the main system clock operates at 6.0 MHz)	

Item		μPD75008	μPD750008	μPD75P0016
Serial interface		3 modes are supported. <ul style="list-style-type: none"> • Three-wire serial I/O mode: First transferred bit switchable between the LSB and MSB • Two-wire serial I/O mode • SBI mode 		
SOS register	Feedback resistor cut flag (SOS.0)	Can incorporate feedback resistors that are specified with the mask option.	Incorporated	
	Sub-oscillator current cut flag (SOS.1)	Not provided	Incorporated	
Register bank selection register (RBS)		Not provided	Provided	
Standby release with INT0		Disable	Enable	
Number of vectored interrupts		External: 3, internal: 3	External: 3, internal: 4	
Processor clock control register		Available when PCC is 0, 2, or 3	Available when PCC is 0 to 3	
Power supply		V _{DD} = 2.7 to 6.0 V	V _{DD} = 2.2 to 5.5 V	
Operating ambient temperature		T _A = -40 to +85 °C		
Package		<ul style="list-style-type: none"> • 42-pin plastic shrink DIP (600 mil, 1.778 mm pitch) • 44-pin plastic QFP (10 × 10 mm, 0.8 mm pitch) 		

APPENDIX B DEVELOPMENT TOOLS

The following development tools are provided for the development of a system which employs the μPD750008. In the 75XL series, use the common relocatable assembler together with a device file of each model.

Language processors

RA75X relocatable assembler	Host machine	OS	Distribution media	Part number
	PC-9800 series		MS-DOS™ Ver. 3.30 to Ver. 6.2 ^{Note}	3.5-inch 2HD
5.25-inch 2HD				μS5A10RA75X
IBM PC/AT™ and compatibles		See "OS for IBM PC."	3.5-inch 2HC	μS7B13RA75X
			5.25-inch 2HC	μS7B10RA75X

Device file	Host machine	OS	Distribution media	Part number
	PC-9800 series		MS-DOS Ver. 3.30 to Ver. 6.2 ^{Note}	3.5-inch 2HD
5.25-inch 2HD				μS5A10DF750008
IBM PC/AT and compatibles		See "OS for IBM PC."	3.5-inch 2HC	μS7B13DF750008
			5.25-inch 2HC	μS7B10DF750008

Note These software products cannot use the task swap function, which is available in MS-DOS Ver. 5.00 or later.

Remark The operations of the assembler and device file are guaranteed only on the above host machines and OSs.

PROM programming tools

Hardware	PG-1500	The PG-1500 PROM programmer is used together with an accessory board and optional program adapter. It allows the user to program a single chip microcontroller containing PROM from a standalone terminal or a host machine. The PG-1500 can be used to program typical 256K-bit to 4M-bit PROMs.			
	PA-75P008CU	The PA-75P008CU is a PROM programmer adapter provided for the μPD75P0016CU/GB. It is used in conjunction with the PG-1500.			
Software	PG-1500 controller	This program enables the host machine to control the PG-1500 through the serial and parallel interfaces.			
		Host machine	OS	Distribution media	Part number
		PC-9800 series	MS-DOS Ver. 3.30 to Ver. 6.2 ^{Note}	3.5-inch 2HD	μS5A13PG1500
				5.25-inch 2HD	μS5A10PG1500
		IBM PC/AT and compatibles	See "OS for IBM PC."	3.5-inch 2HD	μS7B13PG1500
5.25-inch 2HC	μS7B10PG1500				

Note These software products cannot use the task swap function, which is available in MS-DOS Ver. 5.00 or later.

Remark Operation of the PG-1500 controller is guaranteed only on the above host machines and OSs.

Debugging tools

The in-circuit emulators (IE-75000-R and IE-75001-R) are provided to debug programs used for the μPD750008. The system configuration is shown below.

Hardware	IE-75000-R ^{Note 1}	<p>The IE-75000-R is an in-circuit emulator used to debug hardware and software when developing an application system using the 75X series and 75XL series. Use this emulator together with optional emulation board IE-75300-R-EM and emulation probe EP-75008CU-R or EP-75008G to develop application systems of the μPD750008 subseries.</p> <p>For efficient debugging, connect the emulator to the host machine and a PROM programmer.</p> <p>The IE-75000-R contains emulation board IE-75000-R-EM. The board is connected to the IE-75000-R.</p>			
	IE-75001-R	<p>The IE-75001-R is an in-circuit emulator used to debug hardware and software when developing an application system using the 75X series and 75XL series. Use this emulator together with optional emulation board IE-75300-R-EM and emulation probe EP-75008CU-R or EP-75008GB-R to develop application systems of the μPD750008 subseries.</p> <p>For efficient debugging, connect the emulator to the host machine and a PROM programmer.</p>			
	IE-75300-R-EM	<p>The IE-75300-R-EM is an emulation board used to evaluate an application system using the μPD750008 subseries.</p> <p>Use this board together with the IE-75000-R or IE-75001-R.</p>			
	EP-75008CU-R	<p>The EP-75008CU-R is an emulation probe for the μPD750008CU.</p> <p>Connect this emulation probe to the IE-75000-R or IE-75001-R, and the IE-75300-R-EM.</p>			
	EP-75008GB-R	<p>The EP-75008GB-R is an emulation probe for the μPD750008GB.</p> <p>Connect this emulation probe to the IE-75000-R or IE-75001-R, and the IE-75300-R-EM.</p>			
	EV-9200G-44	<p>A 44-pin conversion socket, the EV-9200G-44, supplied with this probe facilitates the connection of the probe to the target system.</p>			
Software	IE control program	<p>This program enables the host machine to control the IE-75000-R or IE-75001-R through the RS-232-C and Centronics interface.</p>			
		Host machine	OS	Distribution media	Part number
		PC-9800 series	MS-DOS Ver. 3.30 to Ver. 6.2 ^{Note 2}	3.5-inch 2HD	μS5A13IE75X
				5.25-inch 2HD	μS5A10IE75X
		IBM PC/AT and compatibles	See "OS for IBM PC."	3.5-inch 2HC	μS7B13IE75X
	5.25-inch 2HC			μS7B10IE75X	

Notes 1. Maintenance service only

2. These software products cannot use the task swap function, which is available in MS DOS Ver. 5.00 or later.

Remarks 1. Operation of the IE control program is guaranteed only on the above host machines and OSs.

2. The μPD750004, μPD750006, μPD750008, and μPD75P0016 are collectively called the μPD750008 subseries.

OS for IBM PC

The following IBM PC OSs are supported.

OS	Version
PC DOSTM	Ver. 3.1 to Ver. 6.3 J6.1/VNote to J6.3/VNote
MS-DOS	Ver. 5.0 to Ver. 6.22 5.0/VNote to 6.2/VNote
IBM DOSTM	J5.02/VNote

Note Only English version is supported.

Caution These software products cannot use the task swap function, which is available in MS-DOS Ver. 5.0 or later.

★ APPENDIX C RELATED DOCUMENTS

Some documents are preliminary editions, but they are not so specified in the tables below.

Documents related to devices

Document name	Document number	
	Japanese	English
μPD750004, 750006, 750008, 750004(A), 750006(A), 750008(A) Data Sheet	U10738J	U10738E (This manual)
μPD75P0016 Data Sheet	U10328J	U10328E
μPD750008 User's Manual	U10740J	U10740E
μPD750008 Instruction List	IEM-5593	-
75XL Series Selection Guide	U10453J	U10453E

Documents related to development tools

Document name			Document number	
			Japanese	English
Hardware	IE-75000-R/IE-75001-R User's Manual		EEU-846	EEU-1416
	IE-75300-R-EM User's Manual		U11354J	U11354E
	EP-75008CU-R User's Manual		EEU-699	EEU-1317
	EP-75008GB-R User's Manual		EEU-698	EEU-1305
	PG-1500 User's Manual		U11940J	EEU-1335
Software	RA75X Assembler Package User's Manual	Operation	EEU-731	EEU-1346
		Language	EEU-730	EEU-1363
	PG-1500 Controller User's Manual	PC-9800 series (MS-DOS) base	EEU-704	EEU-1291
IBM PC series (PC DOS) base		EEU-5008	U10540E	

Other related documents

Document name	Document number	
	Japanese	English
IC Package Manual	C10943X	
Semiconductor Device Mounting Technology Manual	C10535J	C10535E
Quality Grade on NEC Semiconductor Devices	C11531J	C11531E
Reliability and Quality Control of NEC Semiconductor Devices	C10983J	C10983E
Electrostatic Discharge (ESD) Test	MEM-539	-
Semiconductor Device Quality Guarantee Guide	C11893J	MEI-1202
Microcontroller-Related Products Guide - by third parties	U11416J	-

Caution The above related documents are subject to change without notice. Be sure to use the latest edition when you design your system.

NOTES FOR CMOS DEVICES

① PRECAUTION AGAINST ESD FOR SEMICONDUCTORS

Note: Strong electric field, when exposed to a MOS device, can cause destruction of the gate oxide and ultimately degrade the device operation. Steps must be taken to stop generation of static electricity as much as possible, and quickly dissipate it once, when it has occurred. Environmental control must be adequate. When it is dry, humidifier should be used. It is recommended to avoid using insulators that easily build static electricity. Semiconductor devices must be stored and transported in an anti-static container, static shielding bag or conductive material. All test and measurement tools including work bench and floor should be grounded. The operator should be grounded using wrist strap. Semiconductor devices must not be touched with bare hands. Similar precautions need to be taken for PW boards with semiconductor devices on it.

② HANDLING OF UNUSED INPUT PINS FOR CMOS

Note: No connection for CMOS device inputs can be cause of malfunction. If no connection is provided to the input pins, it is possible that an internal input level may be generated due to noise, etc., hence causing malfunction. CMOS device behave differently than Bipolar or NMOS devices. Input levels of CMOS devices must be fixed high or low by using a pull-up or pull-down circuitry. Each unused pin should be connected to V_{DD} or GND with a resistor, if it is considered to have a possibility of being an output pin. All handling related to the unused pins must be judged device by device and related specifications governing the devices.

③ STATUS BEFORE INITIALIZATION OF MOS DEVICES

Note: Power-on does not necessarily define initial status of MOS device. Production process of MOS does not define the initial operation status of the device. Immediately after the power source is turned ON, the devices with reset function have not yet been initialized. Hence, power-on does not guarantee out-pin levels, I/O settings or contents of registers. Device is not initialized until the reset signal is received. Reset operation must be executed immediately after power-on for devices having reset function.

Regional Information

Some information contained in this document may vary from country to country. Before using any NEC product in your application, please contact the NEC office in your country to obtain a list of authorized representatives and distributors. They will verify:

- Device availability
- Ordering information
- Product release schedule
- Availability of related technical literature
- Development environment specifications (for example, specifications for third-party tools and components, host computers, power plugs, AC supply voltages, and so forth)
- Network requirements

In addition, trademarks, registered trademarks, export restrictions, and other legal issues may also vary from country to country.

NEC Electronics Inc. (U.S.)

Santa Clara, California
 Tel: 800-366-9782
 Fax: 800-729-9288

NEC Electronics (Germany) GmbH

Duesseldorf, Germany
 Tel: 0211-65 03 02
 Fax: 0211-65 03 490

NEC Electronics (UK) Ltd.

Milton Keynes, UK
 Tel: 01908-691-133
 Fax: 01908-670-290

NEC Electronics Italiana s.r.l.

Milano, Italy
 Tel: 02-66 75 41
 Fax: 02-66 75 42 99

NEC Electronics (Germany) GmbH

Benelux Office
 Eindhoven, The Netherlands
 Tel: 040-2445845
 Fax: 040-2444580

NEC Electronics (France) S.A.

Velizy-Villacoublay, France
 Tel: 01-30-67 58 00
 Fax: 01-30-67 58 99

NEC Electronics (France) S.A.

Spain Office
 Madrid, Spain
 Tel: 01-504-2787
 Fax: 01-504-2860

NEC Electronics (Germany) GmbH

Scandinavia Office
 Taeby, Sweden
 Tel: 08-63 80 820
 Fax: 08-63 80 388

NEC Electronics Hong Kong Ltd.

Hong Kong
 Tel: 2886-9318
 Fax: 2886-9022/9044

NEC Electronics Hong Kong Ltd.

Seoul Branch
 Seoul, Korea
 Tel: 02-528-0303
 Fax: 02-528-4411

NEC Electronics Singapore Pte. Ltd.

United Square, Singapore 1130
 Tel: 253-8311
 Fax: 250-3583

NEC Electronics Taiwan Ltd.

Taipei, Taiwan
 Tel: 02-719-2377
 Fax: 02-719-5951

NEC do Brasil S.A.

Sao Paulo-SP, Brasil
 Tel: 011-889-1680
 Fax: 011-889-1689

[MEMO]

MS-DOS is a trademark of Microsoft Corporation.

IBM DOS, PC/AT, and PC DOS is a trademark of IBM Corporation.

The export of this product from Japan is regulated by the Japanese government. To export this product may be prohibited without governmental license, the need for which must be judged by the customer. The export or re-export of this product from a country other than Japan may also be prohibited without a license from that country. Please call an NEC sales representative.

No part of this document may be copied or reproduced in any form or by any means without the prior written consent of NEC Corporation. NEC Corporation assumes no responsibility for any errors which may appear in this document.

NEC Corporation does not assume any liability for infringement of patents, copyrights or other intellectual property rights of third parties by or arising from use of a device described herein or any other liability arising from use of such device. No license, either express, implied or otherwise, is granted under any patents, copyrights or other intellectual property rights of NEC Corporation or others.

While NEC Corporation has been making continuous effort to enhance the reliability of its semiconductor devices, the possibility of defects cannot be eliminated entirely. To minimize risks of damage or injury to persons or property arising from a defect in an NEC semiconductor device, customers must incorporate sufficient safety measures in its design, such as redundancy, fire-containment, and anti-failure features.

NEC devices are classified into the following three quality grades:

"Standard", "Special", and "Specific". The Specific quality grade applies only to devices developed based on a customer designated "quality assurance program" for a specific application. The recommended applications of a device depend on its quality grade, as indicated below. Customers must check the quality grade of each device before using it in a particular application.

Standard: Computers, office equipment, communications equipment, test and measurement equipment, audio and visual equipment, home electronic appliances, machine tools, personal electronic equipment and industrial robots

Special: Transportation equipment (automobiles, trains, ships, etc.), traffic control systems, anti-disaster systems, anti-crime systems, safety equipment and medical equipment (not specifically designed for life support)

Specific: Aircrafts, aerospace equipment, submersible repeaters, nuclear reactor control systems, life support systems or medical equipment for life support, etc.

The quality grade of NEC devices is "Standard" unless otherwise specified in NEC's Data Sheets or Data Books. If customers intend to use NEC devices for applications other than those specified for Standard quality grade, they should contact an NEC sales representative in advance.

Anti-radioactive design is not implemented in this product.