

Features

- ✧ Glass passivated junction chip.
- ✧ For surface mounted application
- ✧ Low forward voltage drop
- ✧ Low profile package
- ✧ Built-in strain relief, ideal for automatic placement
- ✧ Fast switching for high efficiency
- ✧ High temperature soldering: 260°C/10 seconds at terminals
- ✧ Meet MSL level 1, per J-STD-020D, lead free maximum peak of 260°C
- ✧ Plastic material used carries Underwriters Laboratory Classification 94V-0
- ✧ Green compound with suffix "G" on packing code & prefix "G" on datecode



Mechanical Data

- ✧ Cases: Molded plastic
- ✧ Terminal: Pure tin plated, lead free
- ✧ Polarity: Indicated by cathode band
- ✧ Weight: 0.0196 grams

Ordering Information (example)

Part No.	Package	Packing	Packing code	Green Compound Packing code
HS1AL	Sub-SMA	3K / 7" REEL	RV	RVG

Maximum Ratings and Electrical Characteristics

Rating at 25 °C ambient temperature unless otherwise specified.

Single phase, half wave, 60 Hz, resistive or inductive load.

For capacitive load, derate current by 20%

Type Number	Symbol	HS 1AL	HS 1BL	HS 1DL	HS 1FL	HS 1GL	HS 1JL	HS 1KL	HS 1ML	Units	
Maximum Recurrent Peak Reverse Voltage	V_{RRM}	50	100	200	300	400	600	800	1000	V	
Maximum RMS Voltage	V_{RMS}	35	70	140	210	280	420	560	700	V	
Maximum DC Blocking Voltage	V_{DC}	50	100	200	300	400	600	800	1000	V	
Marking Code		HAL	HBL	HDL	HFL	HGL	HJL	HKL	HML		
Maximum Average Forward Rectified Current	$I_{F(AV)}$	1								A	
Peak Forward Surge Current, 8.3 ms Single Half Sine-wave Superimposed on Rated Load (JEDEC method)	I_{FSM}	30								A	
Maximum Instantaneous Forward Voltage (Note 1) @ 1 A	V_F	1.0			1.3		1.7			V	
Maximum DC Reverse Current @ $T_A=25\text{ }^\circ\text{C}$ at Rated DC Blocking Voltage @ $T_A=125\text{ }^\circ\text{C}$	I_R	5 150								μA	
Maximum Reverse Recovery Time (Note 2)	T_{rr}	50					75				nS
Typical Junction Capacitance (Note 3)	C_j	20					15				pF
Typical Thermal Resistance	$R_{\theta JA}$	100								$^\circ\text{C/W}$	
Operating Junction Temperature Range	T_J	- 55 to + 150								$^\circ\text{C}$	
Storage Temperature Range	T_{STG}	- 55 to + 150								$^\circ\text{C}$	

Note 1: Pulse Test with PW=300 usec, 1% Duty Cycle

Note 2: Reverse Recovery Test Conditions: $I_F=0.5\text{A}$, $I_R=1.0\text{A}$, $I_{RR}=0.25\text{A}$

Note 3: Measured at 1 MHz and Applied Reverse Voltage of 4.0Volts.

Version:A12

RATINGS AND CHARACTERISTIC CURVES (HS1AL THRU HS1ML)

FIG. 1- MAXIMUM AVERAGE FORWARD CURRENT DERATING

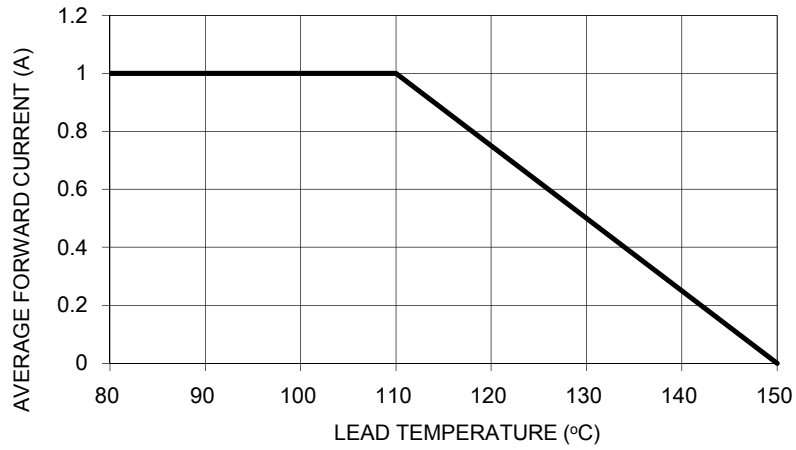

FIG. 2- TYPICAL REVERSE CHARACTERISTICS

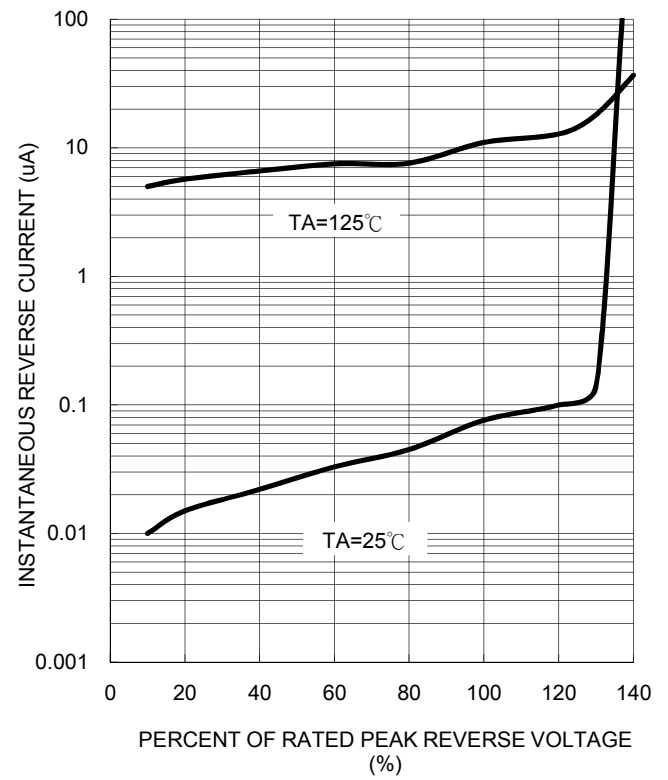

FIG. 3- MAXIMUM NON-REPETITIVE FORWARD SURGE CURRENT

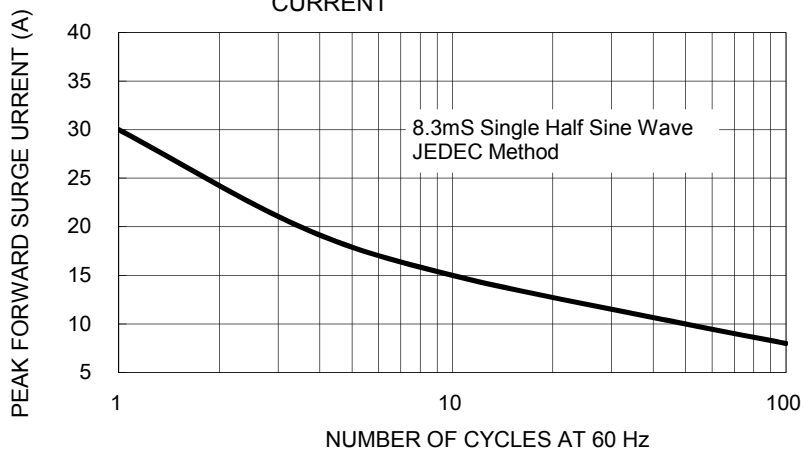

FIG. 5- TYPICAL INSTANTANEOUS FORWARD CHARACTERISTICS

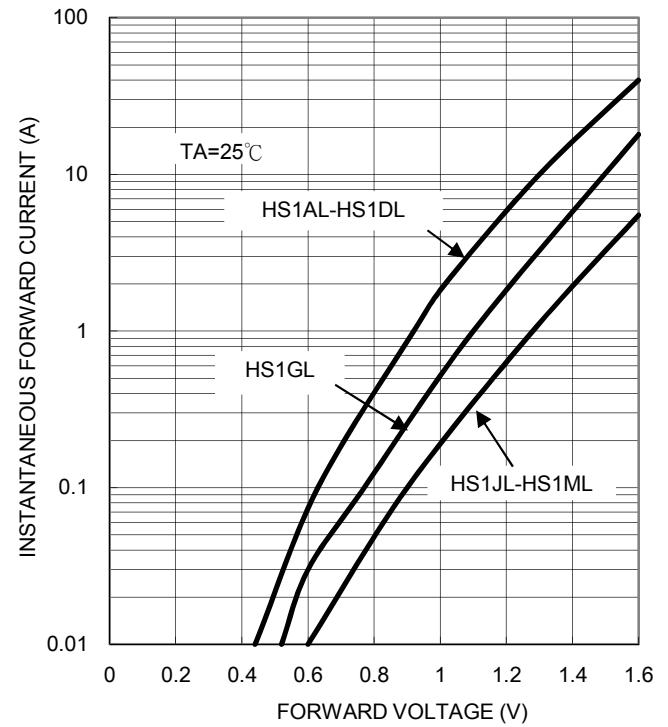

FIG. 4- TYPICAL JUNCTION CAPACITANCE

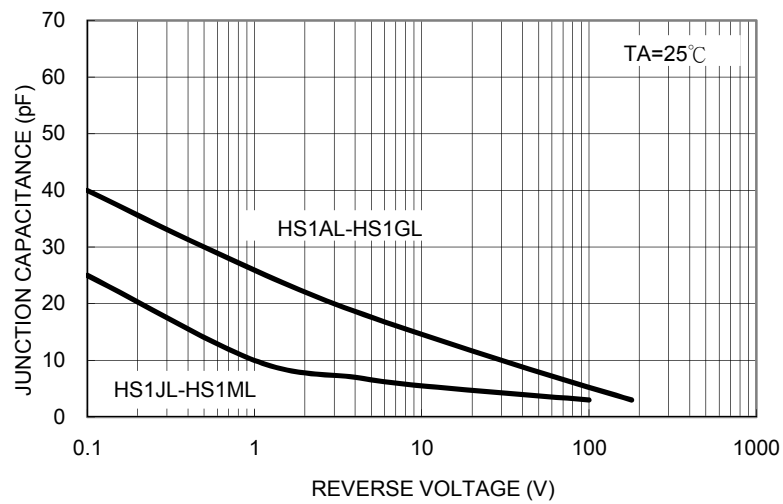
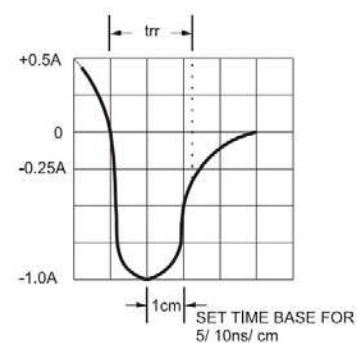
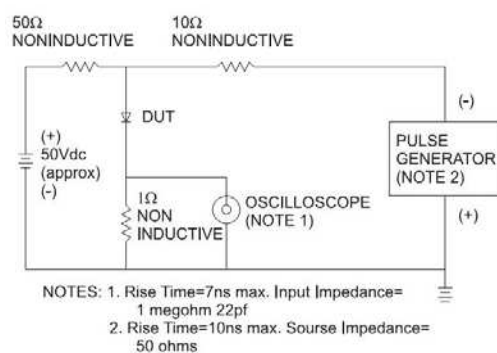

FIG. 6- REVERSE RECOVERY TIME CHARACTERISTIC AND TEST CIRCUIT DIAGRAM



Ordering information

Part No.	Package	Packing	Tape Size	Packing code	Green Compound Packing code
HS1XL (Note)	Sub-SMA	1.8K / 7" REEL	8mm	RU	RUG
	Sub-SMA	3K / 7" REEL	8mm	RV	RVG
	Sub-SMA	7.5K / 13" REEL	8mm	RT	RTG
	Sub-SMA	7.5K / 13" REEL	8mm	MT	MTG
	Sub-SMA	10K / 13" REEL	8mm	RQ	RQG
	Sub-SMA	10K / 13" REEL	8mm	MQ	MQG
	Sub-SMA	1.8K / 7" REEL	12mm	R3	R3G
	Sub-SMA	3K / 7" REEL	12mm	RF	RFG
	Sub-SMA	7.5K / 13" REEL	12mm	R2	R2G
	Sub-SMA	7.5K / 13" REEL	12mm	M2	M2G
	Sub-SMA	10K / 13" REEL	12mm	RH	RHG
	Sub-SMA	10K / 13" REEL	12mm	MH	MHG

Note: "x" is Device Code from "A" thru "M".

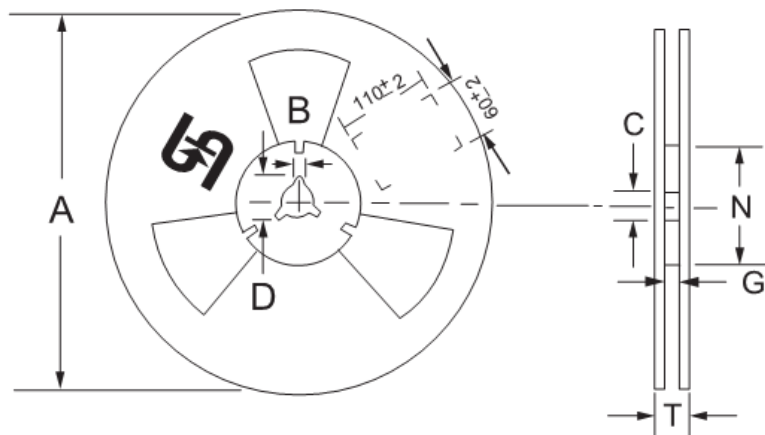
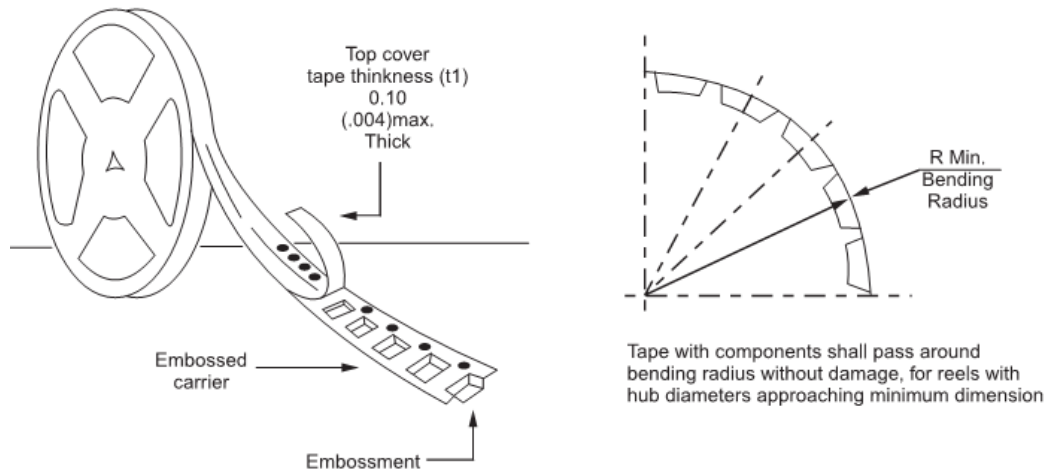
Tape & Reel specification

Reel Size	Tape Size	A	B	C	D	N	G	T
		±2.0	±0.4	+0.5;-0.2	min	±1.0	+0.8;-0	max
7"	8mm	178	1.9	13	21	62	8.2	10.6
	12mm						12.2	14.6
		A	B	C	D	N	G	T
		max	±0.5	±0.5	min	±0.5	+2.0;-0	max
13"	8mm	330	2	13	20.2	75	8.5	14.5
	12mm						12.4	18.4

Unit (mm)

Suggested PAD Layout

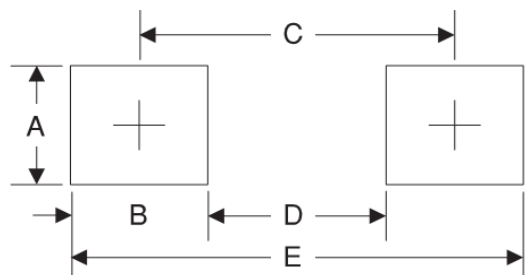

Symbol	Unit(mm)
A	1.4
B	1.2
C	3.1
D	1.9
E	4.3

Package Outline Dimensions

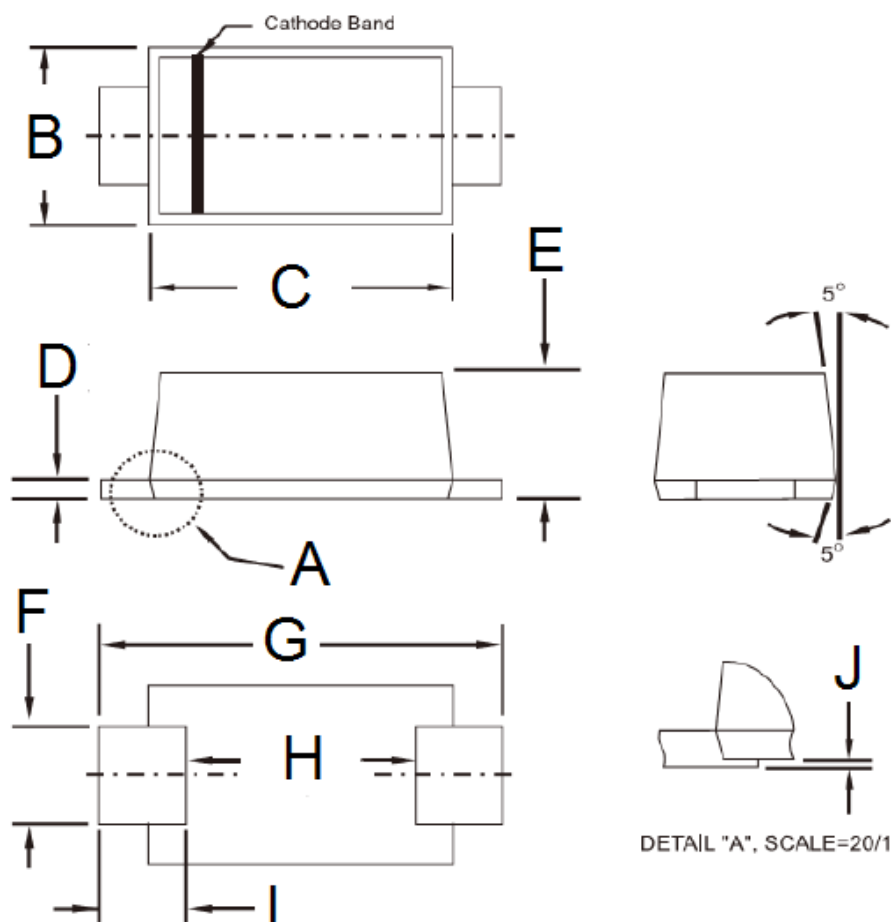

DIM.	Unit(mm)		Unit(inch)	
	Min	Max	Min	Max
B	1.70	1.90	0.067	0.075
C	2.70	2.90	0.106	0.114
D	0.16	0.30	0.006	0.012
E	1.23	1.43	0.048	0.056
F	0.80	1.20	0.031	0.047
G	3.40	3.80	0.134	0.150
H	2.45	2.60	0.096	0.102
I	0.35	0.85	0.014	0.033
J	0.00	0.10	0.000	0.004

Marking Diagram



P/NL = Specific Device Code
 G = Green Compound
 YW = Date Code