

MAX96709

14-Bit GMSL Serializer with High-Immunity Mode and Coax/STP Cable Drive

General Description

The MAX96709 is a compact serializer in a 4mm x 4mm TQFN package especially suited for automotive camera applications.

The embedded control channel operates at 9.6kbps to 1Mbps in I²C mode, allowing programming of serializer, deserializer, and camera registers independent of video timing.

For driving longer cables, the IC has programmable pre/deemphasis. Programmable spread spectrum is available on the serial output. The serial output meets ISO 10605 and IEC 61000-4-2 ESD standards. The supply range is 1.7V to 1.9V.

The MAX96709 is available in a 24-pin 0.5mm lead pitch, and operates over the -40°C to +115°C temperature range.

Applications

- Automotive Camera Applications

Simplified Block Diagram

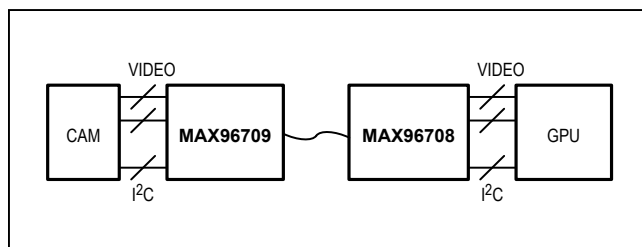

Benefits and Features

- Ideal for Safety Camera Applications
 - Works with Low-Cost 50Ω Coax (100Ω STP) Cables
 - Error Detection of Video Data
 - High-Immunity Mode for Robust Control-Channel EMC Tolerance
 - Best-in-Class Supply Current: 88mA (max)
 - Pre/Deemphasis Allows 15m Cable at Full Speed
 - 24-Pin (4mm x 4mm) TQFN Package with 0.5mm Lead Pitch
- High-Speed Data Serialization for Megapixel Cameras
 - Up to 1.74Gbps Serial-Bit Rate
 - 12.5MHz to 87MHz x 12 Bit + H/V Data
 - 16.66MHz to 116MHz x 11-Bit + H/V Data (through Internal Encoding)
- Multiple Modes for System Flexibility
 - 9.6kbps to 1Mbps Control Channel in I²C Mode (with Clock Stretch)
 - Crosspoint Switch Accepts Any Input Bitmap
 - Modes for Encoded VSYNC and HSYNC
- Reduces EMI and Shielding Requirements
 - Programmable Output Spread Spectrum
 - Tracks Spread Spectrum Applied at the Parallel Input
 - 1.7V to 1.9V I/O Supply
- Peripheral Features for Camera Power-Up and Verification
 - Built-In PRBS Generator for BER Testing
 - Dedicated GPO for Camera Frame-Sync Trigger and Other Uses
 - Remote/Local Wake-Up from Sleep Mode
- Meets AEC-Q100 Automotive Specification
 - -40°C to +115°C Operating Temperature
 - ±8kV Contact and ±15kV Air IEC 61000-4-2 and ISO 10605 ESD Protection

Ordering Information appears at end of data sheet.

TABLE OF CONTENTS

General Description	1
Applications	1
Benefits and Features	1
Simplified Block Diagram	1
Absolute Maximum Ratings	7
Package Information	7
24-Pin TQFN-EP	7
DC Electrical Characteristics	8
AC Electrical Characteristics	10
Typical Operating Characteristics	13
Pin Configuration	15
Pin Description	15
Functional Block Diagram	17
Detailed Description	22
Serial Link Signaling and Data Format	22
Operating Modes	22
Video/Configuration Link	22
Single/Double Mode	23
HS/VS Encoding	23
Error Detection	23
Bus Widths	23
Control Channel and Register Programming	26
Forward Control Channel	26
Reverse Control Channel	26
I ² C Interface	26
Remote-End Operation	26
Clock-Stretch Timing	26
GPO/GPI Control	26
Spread Spectrum	27
Cable Type Configuration	27
Crossbar Switch	27
Shutdown/Sleep Modes	28
Configuration Link	28
Serialization Disable	28
Sleep Mode	28
Link Startup Procedure	29

TABLE OF CONTENTS (CONTINUED)

Register Map	30
GMSL Register Map	30
seraddr (0x00)	34
desaddr (0x01)	34
ss (0x02)	35
sdiv (0x03)	35
main_control (0x04)	36
prbs_len (0x05)	36
cmlvl_preemp (0x06)	37
config (0x07)	38
rsvd_8 (0x08)	38
i2c_source (0x09, 0x0B)	39
i2c_dest (0x0A, 0x0C)	39
i2c_config (0x0D)	40
gpio_en (0x0E)	41
gpio_out (0x0F)	41
gpio_in (0x10)	42
errg (0x11)	42
rsvd_12 (0x12)	43
pd (0x13)	43
rsvd_14 (0x14)	43
input_status (0x15)	44
rsvd_16 (0x16)	44
rsvd_17 (0x17)	44
rsvd (0x18 to 0x1B)	45
rsvd (0x1C)	45
rsvd_1D (0x1D)	45
id (0x1E)	45
revision (0x1F)	46
crossbar (0x20 to 0x3E)	46
crossbar_hs (0x3F)	47
crossbar_vs (0x40)	47
crossbar_de (0x41)	48
link_config (0x42)	48
rsvd_43 (0x43)	49
rsvd (0x44 to 0x46)	49
rsvd (0x47 to 0x49)	49

TABLE OF CONTENTS (CONTINUED)

rsvd (0x4A to 0x4C)	49
cxtp (0x4D)	50
rsvd (0x4E to 0x50)	50
rsvd (0x51 to 0x53, 0x5D to 0x5F)	50
rsvd (0x54, 0x55)	51
rsvd (0x56, 0x57)	51
rsvd (0x58, 0x59)	51
rsvd (0x5A to 0x5C)	51
rsvd (0x60, 0x61)	51
rsvd (0x62, 0x63)	52
rsvd (0x64, 0x65)	52
prbs_type (0x66)	52
auto_clink (0x67)	53
rsvd_68 (0x68)	53
rsvd_69 (0x69)	53
rsvd_96 (0x96)	54
rsvd_97 (0x97)	54
rsvd_98 (0x98)	54
rsvd_99 (0x99)	55
rsvd_9A (0x9A)	55
rsvd_C8 (0xC8)	55
rsvd_c9 (0xC9)	56
rsvd_fc (0xFC)	56
rsvd_fd (0xFD)	56
rsvd_fe (0xFE)	57
rsvd_ff (0xFF)	57
Applications Information	58
Parallel Interface	58
Bus Data Width	58
Bus Data Rates	58
Crossbar-Switch Programming	59
Recommended Crossbar-Switch Program Procedure	59

TABLE OF CONTENTS (CONTINUED)

I ² C Interface	60
I ² C Bit Rate	60
Software Programming of Device Addresses	60
I ² C Address Translation	60
Configuration Blocking	60
Cascaded/Parallel Devices	60
Device Address	61
Spread Spectrum	61
Manual Programming of the Spread-Spectrum Divider	61
Equation:	61
Board Layout	62
Power-Supply Circuits and Bypassing	62
High-Frequency Signals	62
ESD Protection	62
Compatibility with Other GMSL Devices	63
Device Configuration and Component Selection	63
Internal Input Pulldowns	63
I ² C Pullup Resistors	63
AC-Coupling Capacitors	63
Cables and Connectors	64
PRBS	64
GPI/GPO	64
Fast Detection of Loss-of-Lock	64
Providing a Frame Sync (Camera Applications)	64
Entering/Exiting Sleep Mode	64
Typical Application Circuits	65
Ordering Information	65
Revision History	66

LIST OF FIGURES

Figure 1. Serial-Output Parameters	15
Figure 2. Output Waveforms at OUT+, OUT-	16
Figure 3. Single-Ended Output Template	16
Figure 4. Worst-Case Pattern Input	16
Figure 5. Parallel Clock Input Requirements	16
Figure 6. I ² C Timing Parameters	17
Figure 7. Differential Output Template	17
Figure 8. Input Setup and Hold Times	18
Figure 9. GPI-to-GPO Delay	18
Figure 10. Serializer Delay	19
Figure 11. Link Startup Time	19
Figure 12. Power-Up Delay	20
Figure 13. 24-Bit Mode Serial-Data Format	22
Figure 14. 32-Bit Mode Serial-Data Format	23
Figure 15. Coax Connection	25
Figure 16. Crossbar-Switch Dataflow	25
Figure 17. State Diagram	26
Figure 18. Crossbar-Switch Default Mapping	57
Figure 19. Human Body Model ESD Test Circuit	60
Figure 20. IEC 61000-4-2 Contact Discharge ESD Test Circuit	60
Figure 21. ISO 10605 Contact Discharge ESD Test Circuit	60

LIST OF TABLES

Table 1. Reverse Control-Channel Modes	24
Table 2. Link-Startup Procedure	27
Table 3. Input Data-Width Selection	56
Table 4. Data-Rate Selection	56
Table 5. Output Spread	59
Table 6. Spread Limitations	59
Table 7. Modulation Coefficients and Maximum SDIV Settings	60
Table 8. Feature Compatibility	61
Table 9. Suggested Connectors and Cables for GMSL	62

Absolute Maximum Ratings

AVDD to GND*	-0.5V to +1.9V	Continuous Power Dissipation, T _A = +70°C
DVDD to GND*	-0.5V to +1.9V	TQFN (derate 27.8mW/°C above +70°C).....
OUT+, OUT- to GND*	-0.5V to +1.9V	Operating Temperature Range.....
All Other Pins to GND*	-0.5V to (DVDD + 0.5V)	Junction Temperature.....
OUT+, OUT- Short Circuit to Ground or Supply.....	Continuous	Storage Temperature Range.....
		Soldering Temperature (reflow).....

*EP externally connected to GND.

Stresses beyond those listed under "Absolute Maximum Ratings" may cause permanent damage to the device. These are stress ratings only, and functional operation of the device at these or any other conditions beyond those indicated in the operational sections of the specifications is not implied. Exposure to absolute maximum rating conditions for extended periods may affect device reliability.

Package Information

For the latest package outline information and land patterns (footprints), go to www.maximintegrated.com/packages. Note that a "+", "#", or "-" in the package code indicates RoHS status only. Package drawings may show a different suffix character, but the drawing pertains to the package regardless of RoHS status.

24-Pin TQFN-EP

Package Code	T2444+4
Outline Number	21-0139
Land Pattern Number	90-0022
Single-Layer Board:	
Junction-to-Ambient Thermal Resistance (θ _{JA})	48
Junction-to-Case Thermal Resistance (θ _{JC})	3
Four-Layer Board:	
Junction-to-Ambient Thermal Resistance (θ _{JA})	36
Junction-to-Case Thermal Resistance (θ _{JC})	3

Package thermal resistances were obtained using the method described in JEDEC specification JESD51-7, using a four-layer board. For detailed information on package thermal considerations, refer to www.maximintegrated.com/thermal-tutorial.

DC Electrical Characteristics

($V_{DVDD} = V_{AVDD} = 1.7V$ to $1.9V$, $R_L = 100\Omega \pm 1\%$ (differential), $T_A = -40^\circ C$ to $+115^\circ C$, EP connected to GND, typical values are at $V_{DVDD} = V_{AVDD} = 1.8V$, $T_A = +25^\circ C$, unless otherwise noted.) (Note 1)

PARAMETER	SYMBOL	CONDITIONS	MIN	TYP	MAX	UNITS
SINGLE-ENDED INPUTS (DIN_, PCLKIN, HS, VS, HIM, MS)						
High-Level Input Voltage	V_{IH}		0.65 x V_{DVDD}			V
Low-Level Input Voltage	V_{IL}			0.35 x V_{DVDD}		V
Input Current	I_{IN}	$V_{IN} = 0$ to V_{DVDD}	-20		+20	μA
SINGLE-ENDED OUTPUT (GPO)						
High-Level Output Voltage	V_{OH}	$I_{OH} = -2mA$	$V_{DVDD} - 0.2$			V
Low-Level Output Voltage	V_{OL}	$I_{OL} = 2mA$		0.2		V
Output Short-Circuit Current	I_{OS}	$V_O = 0V$	3	12	21	mA
I²C and GENERAL-PURPOSE I/Os (SDA, SCL, GPIO_) with OPEN-DRAIN OUTPUTS						
High-Level Input Voltage	V_{IH}		0.7 x V_{DVDD}			V
Low-Level Input Voltage	V_{IL}			0.3 x V_{DVDD}		V
Input Current	I_{IN}	$V_{IN} = 0$ to V_{DVDD} (Note 2), SDA, SCL	-110		+5	μA
		$V_{IN} = 0$ to V_{DVDD} (Note 2), GPIO_	-80		+5	
Low-Level Open-Drain Output Voltage	V_{OL}	$I_{OL} = 3mA$		0.4		V
Input Capacitance	C_{IN}	Each pin (Note 3)		10		pF
DIFFERENTIAL OUTPUTS (OUT+, OUT-)						
Differential Output Voltage	V_{OD}	Preemphasis off, high drive (Figure 1)	300	400	500	mV
		3.3dB preemphasis, high drive (Figure 2)	350		610	
		3.3dB deemphasis, high drive (Figure 2)	240		425	
Change in V_{OD} Between Complementary Output States	ΔV_{OD}			25		mV
Output Offset Voltage ($V_{OUT+} + V_{OUT-}$)/2 = V_{OS}	V_{OS}	Preemphasis off	1.1	1.4	1.56	V
Change in V_{OS} Between Complementary Output States	ΔV_{OS}			25		mV
Output Short-Circuit Current	I_{OS}	V_{OUT+} or $V_{OUT-} = 0V$	-60			mA
		V_{OUT+} or $V_{OUT-} = 1.9V$		25		
Magnitude of Differential Output Short-Circuit Current	I_{OSD}	$V_{OD} = 0V$		25		mA
Output-Termination Resistance (Internal)	R_O	From OUT+ or OUT- to AVDD	45	54	63	Ω

DC Electrical Characteristics (continued)

($V_{DVDD} = V_{AVDD} = 1.7V$ to $1.9V$, $R_L = 100\Omega \pm 1\%$ (differential), $T_A = -40^\circ C$ to $+115^\circ C$, EP connected to GND, typical values are at, $V_{DVDD} = V_{AVDD} = 1.8V$, $T_A = +25^\circ C$, unless otherwise noted.) (Note 1)

PARAMETER	SYMBOL	CONDITIONS	MIN	TYP	MAX	UNITS
REVERSE CONTROL-CHANNEL RECEIVER OUTPUTS (OUT+, OUT-)						
High-Switching Threshold	V_{CHR}	Legacy			27	mV
		High immunity			40	
Low-Switching Threshold	V_{CLR}	Legacy	-27			mV
		High immunity	-40			
SINGLE-ENDED SERIAL OUTPUTS (OUT+ or OUT-)						
Single-Ended Output Voltage	V_O	Preemphasis off, high drive (Figure 3)	375	500	625	mV
		3.3dB preemphasis, high drive (Figure 2)	435		765	
		3.3dB deemphasis, high drive (Figure 2)	300		535	
Output Short-Circuit Current	I_{OS}	V_{OUT+} or $V_{OUT-} = 0V$	-69			mA
		V_{OUT+} or $V_{OUT-} = 1.9V$			32	
Output-Termination Resistance (Internal)	R_O	From OUT+ or OUT- to AVDD	45	54	63	Ω
POWER SUPPLY						
Supply Current, Worst-Case Pattern (Figure 4)	I_{WCS}	$f_{PCLKIN} = 116MHz$, BWS = 0, default register values, AVDD + DVDD (1.9V)		66	88	mA
		$f_{PCLKIN} = 87MHz$, BWS = 1, default register values, AVDD + DVDD (1.9V)		62	83	
Sleep-Mode Supply Current	I_{CCS}	Wake-up receiver enabled		40	100	μA
ESD PROTECTION						
OUT+, OUT- (Note 4)	V_{ESD}	Human Body Model, $R_D = 1.5k\Omega$, $C_S = 100pF$		± 8		kV
		IEC 61000-4-2, $R_D = 330\Omega$, $C_S = 150pF$, Contact Discharge		± 8		
		IEC 61000-4-2, $R_D = 330\Omega$, $C_S = 150pF$, Air Discharge		± 15		
		ISO 10605, $R_D = 2k\Omega$, $C_S = 330pF$, Contact Discharge		± 8		
		ISO 10605, $R_D = 2k\Omega$, $C_S = 330pF$, Air Discharge		± 15		
All Other Pins (Note 5)	V_{ESD}	Human Body Model, $R_D = 1.5k\Omega$, $C_S = 100pF$		± 4		kV

AC Electrical Characteristics

($V_{DVDD} = V_{AVDD} = 1.7V$ to $1.9V$, $R_L = 100\Omega \pm 1\%$ (differential), $T_A = -40^\circ C$ to $+115^\circ C$, EP connected to GND, typical values are at, $V_{DVDD} = V_{AVDD} = 1.8V$, $T_A = +25^\circ C$, unless otherwise noted.) (Note 1)

PARAMETER	SYMBOL	CONDITIONS	MIN	TYP	MAX	UNITS
PARALLEL CLOCK INPUT (PCLKIN)						
Clock Frequency	f_{PCLKIN}	BWS = 0, single input	16.66		58	MHz
		BWS = 1, single input	12.5		43.5	
		BWS = 0, double input	33.32		116	
		BWS = 1, double input	25		87	
Clock Duty Cycle	DC	t_{HIGH}/t_T or t_{LOW}/t_T (Note 3, Figure 5)	35	50	65	%
Clock Transition Time	t_R, t_F	(Note 3, Figure 5)			4	ns
Clock Jitter	t_J	1.74Gbps bit rate, 300kHz sinusoidal jitter (Note 3)			800	ps
I²C PORT TIMING						
I ² C Bit Rate			9.6		1000	kbps
Output Rise Time	t_R	30% to 70%, $C_L = 10pF$ to $100pF$, $1k\Omega$ pullup to DVDD	20		150	ns
Output Fall Time	t_F	70% to 30%, $C_L = 10pF$ to $100pF$, $1k\Omega$ pullup to DVDD	20		150	ns
I²C TIMING (Figure 6)						
SCL Clock Frequency	f_{SCL}	Low f_{SCL} range: (I2CMSTBT = 010, I2CSLVSH = 10)	9.6		100	kHz
		Mid f_{SCL} range: (I2CMSTBT 101, I2CSLVSH = 01)	> 100		400	
		High f_{SCL} range: (I2CMSTBT = 111, I2CSLVSH = 00)	> 400		1000	
START Condition Hold Time	$t_{HD:STA}$	f_{SCL} range, low	4			μs
		f_{SCL} range, mid	0.6			
		f_{SCL} range, high	0.26			
Low Period of SCL Clock	t_{LOW}	f_{SCL} range, low	4.7			μs
		f_{SCL} range, mid	1.3			
		f_{SCL} range, high	0.5			
High Period of SCL Clock	t_{HIGH}	f_{SCL} range, low	4			μs
		f_{SCL} range, mid	0.6			
		f_{SCL} range, high	0.26			
Repeated START Condition Setup Time	$t_{SU:STA}$	f_{SCL} range, low	4.7			μs
		f_{SCL} range, mid	0.6			
		f_{SCL} range, high	0.26			

AC Electrical Characteristics (continued)

($V_{DVDD} = V_{AVDD} = 1.7V$ to $1.9V$, $R_L = 100\Omega \pm 1\%$ (differential), $T_A = -40^\circ C$ to $+115^\circ C$, EP connected to GND, typical values are at, $V_{DVDD} = V_{AVDD} = 1.8V$, $T_A = +25^\circ C$, unless otherwise noted.) (Note 1)

PARAMETER	SYMBOL	CONDITIONS	MIN	TYP	MAX	UNITS
Data Hold Time	$t_{HD:DAT}$	f _{SCL} range, low	0			ns
		f _{SCL} range, mid	0			
		f _{SCL} range, high	0			
Data Setup Time	$t_{SU:DAT}$	f _{SCL} range, low	250			ns
		f _{SCL} range, mid	100			
		f _{SCL} range, high	50			
Setup Time for STOP Condition	$t_{SU:STO}$	f _{SCL} range, low	4			μs
		f _{SCL} range, mid	0.6			
		f _{SCL} range, high	0.26			
Bus-Free Time	t_{BUF}	f _{SCL} range, low	4.7			μs
		f _{SCL} range, mid	1.3			
		f _{SCL} range, high	0.5			
Data Valid Time	$t_{VD:DAT}$	f _{SCL} range, low			3.45	μs
		f _{SCL} range, mid			0.9	
		f _{SCL} range, high			0.45	
Data Valid-Acknowledge Time	$t_{VD:ACK}$	f _{SCL} range, low			3.45	μs
		f _{SCL} range, mid			0.9	
		f _{SCL} range, high			0.45	
Pulse Width of Spikes Suppressed	t_{SP}	f _{SCL} range, low			50	ns
		f _{SCL} range, mid			50	
		f _{SCL} range, high			50	
Capacitive Load of Each Bus Line	C_B	(Note 3)			100	pF
SWITCHING CHARACTERISTICS (Note 3)						
Differential/Single-Ended Output Rise/Fall Time	t_R, t_F	20% to 80%, V_{OD} , 400mV differential $R_L = 100\Omega$, 500mV single-ended $R_L = 50\Omega$, serial bit rate = 1.74Gbps			250	ps
Total Serial-Output Jitter (Differential Output)	t_{TSOJ1}	1.74Gbps PRBS, measured at $V_{OD} = 0V$ differential, preemphasis disabled (Figure 7)		0.25		UI
Deterministic Serial-Output Jitter (Differential Output)	t_{DSOJ2}	1.74Gbps PRBS, measured at $V_{OD} = 0V$ differential, preemphasis disabled (Figure 7)		0.15		UI
Total Serial-Output Jitter (Single-Ended Output)	t_{TSOJ1}	1.74Gbps PRBS, measured at $V_O/2$, preemphasis disabled (Figure 3)		0.25		UI

AC Electrical Characteristics (continued)

($V_{DVDD} = V_{AVDD} = 1.7V$ to $1.9V$, $R_L = 100\Omega \pm 1\%$ (differential), $T_A = -40^\circ C$ to $+115^\circ C$, EP connected to GND, typical values are at, $V_{DVDD} = V_{AVDD} = 1.8V$, $T_A = +25^\circ C$, unless otherwise noted.) (Note 1)

PARAMETER	SYMBOL	CONDITIONS	MIN	TYP	MAX	UNITS
Deterministic Serial-Output Jitter (Single-Ended Output)	t_{DSOJ2}	1.74Gbps PRBS, measured at $V_O/2$, preemphasis disabled (Figure 3)		0.15		UI
Parallel Data-Input Setup Time	t_{SET}	(Figure 8)	2			ns
Parallel Data Input Hold Time	t_{HOLD}	(Figure 8) (Note 3)	1			ns
GPI-to-GPO Delay	t_{GPIO}	Deserializer GPI to serializer GPO (Figure 9)			350	μs
Serializer Delay	t_{SD}	Spread spectrum enabled (Figure 10) (Notes 3, 6)			2065	Bits
		Spread spectrum disabled (Figure 10) (Notes 3, 6)			1095	
Link Start Time	t_{LOCK}	(Figure 11)			2	ms
Power-Up Time	t_{PU}	(Figure 12)			7	ms

Note 1: Limits are 100% production tested at $T_A = +115^\circ C$. Limits over the operating temperature range are guaranteed by design and characterization, unless otherwise noted.

Note 2: I_{IN} min is due to voltage drop across the internal pullup resistor.

Note 3: Not production tested. Guaranteed by design.

Note 4: Specified pin to ground.

Note 5: Specified pin to all supply/ground.

Note 6: Measured in serial link bit times. Bit time = $1/(30 \times f_{PCLKIN})$ for BWS = 0; bit time = $1/(40 \times f_{PCLKIN})$ for BWS = 1.

Typical Operating Characteristics

($V_{AVDD} = V_{DVDD} = 1.8V$, $T_A = +25^\circ C$, unless otherwise noted.)

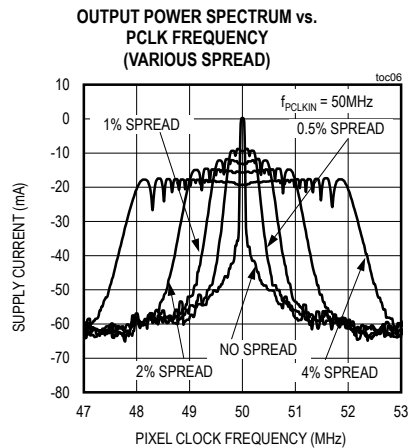
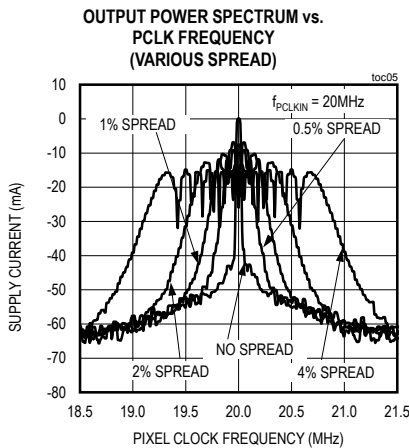
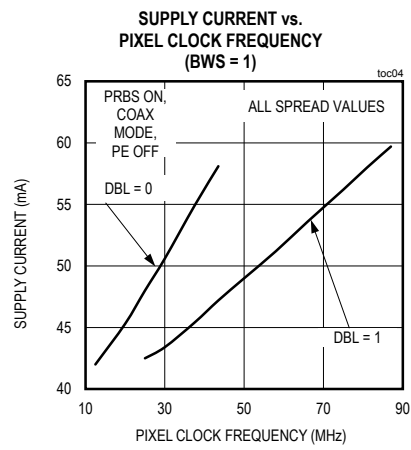
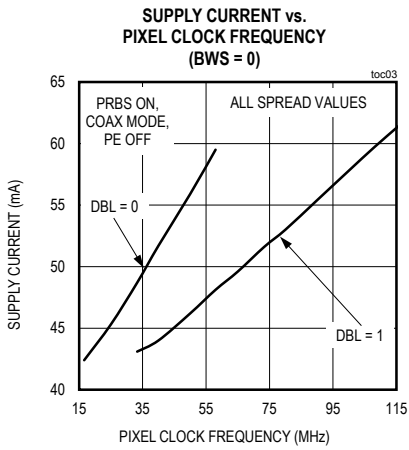
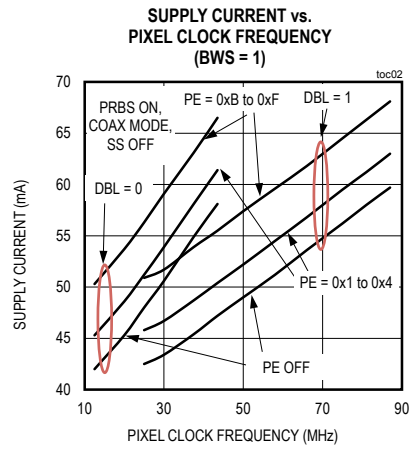
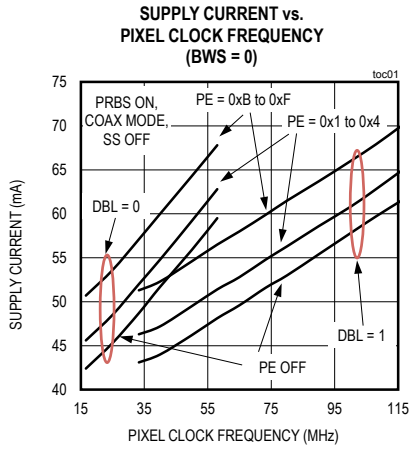

Typical Operating Characteristics (continued)

($V_{AVDD} = V_{DVDD} = 1.8V$, $T_A = +25^\circ C$, unless otherwise noted.)

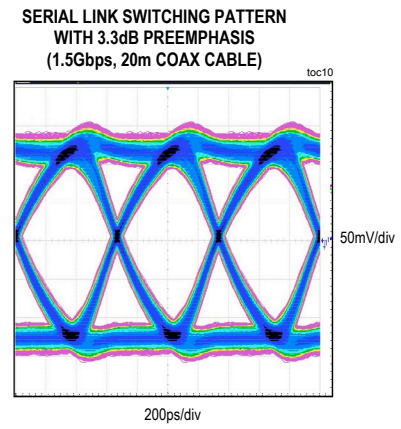
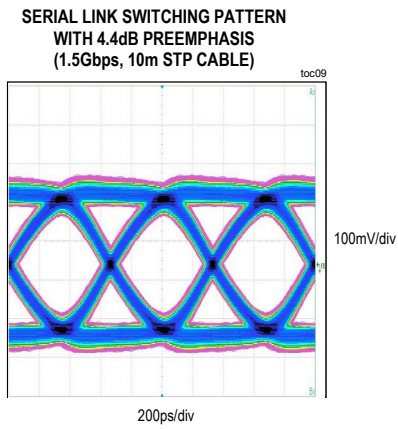
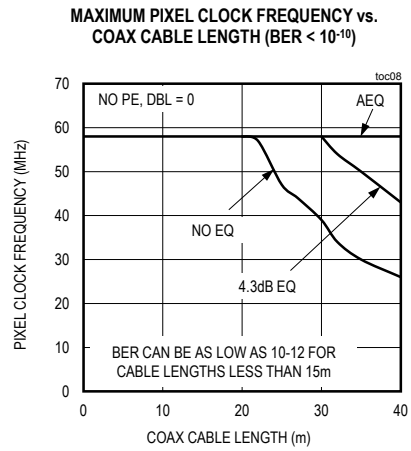
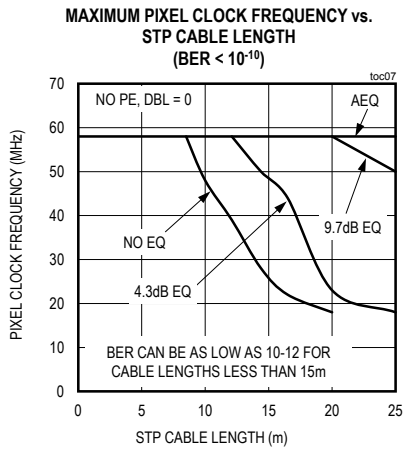

Pin Configuration

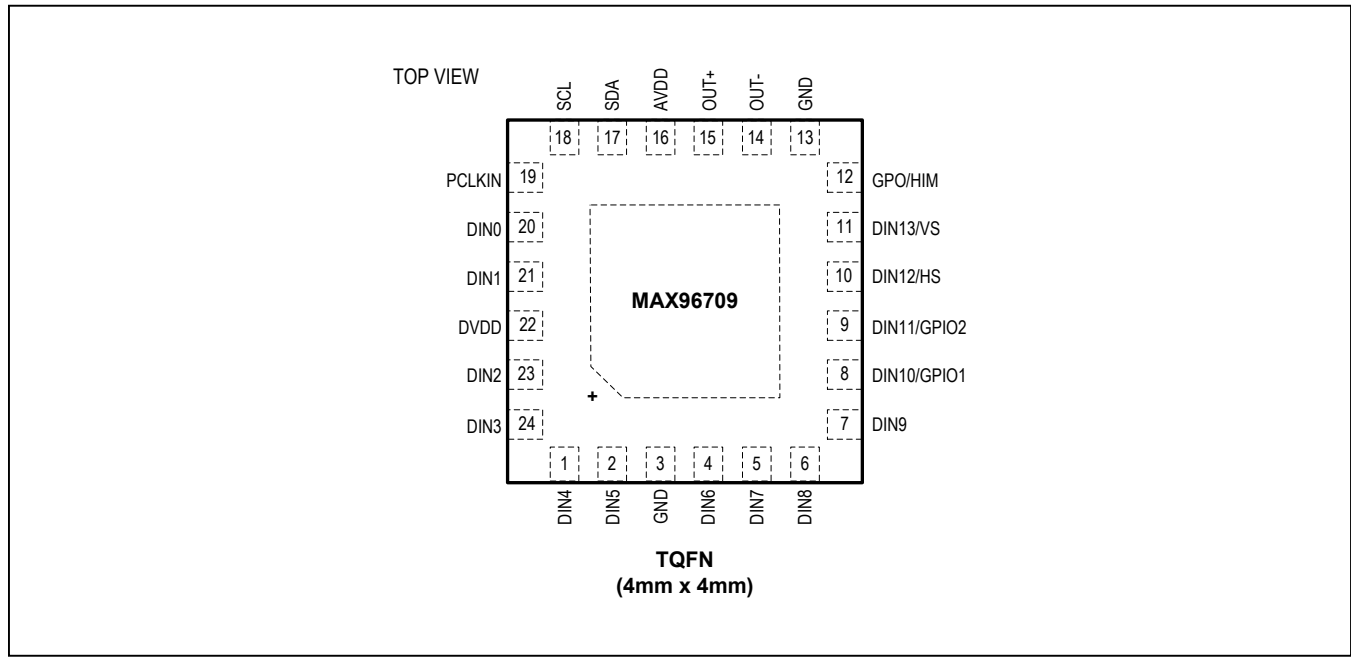

Pin Description

PIN	NAME	FUNCTION	REF SUPPLY	TYPE
POWER				
3, 13	GND	Analog and Digital Ground		Power
16	AVDD	1.8V Analog Power Supply. Bypass AVDD to GND with 0.1µF, and 0.001µF capacitors as close as possible to the device with the smaller value capacitor closest to AVDD.		Power
22	DVDD	1.8V Digital Power Supply. Bypass DVDD to GND with 0.1µF, and 0.001µF capacitors as close as possible to the device with the smaller value capacitor closest to DVDD.		Power
EP	—	Exposed Pad. EP is internally connected to device ground. Must connect EP to the PCB ground plane through a via array for proper thermal and electrical performance.		Power
HIGH-SPEED DIGITAL				
Single Function				
1	DIN4	Parallel Data Input. Internal pulldown to GND.	DVDD	Digital
2	DIN5	Parallel Data Input. Internal pulldown to GND.	DVDD	Digital
4	DIN6	Parallel Data Input. Internal pulldown to GND.	DVDD	Digital
5	DIN7	Parallel Data Input. Internal pulldown to GND.	DVDD	Digital
6	DIN8	Parallel Data Input. Internal pulldown to GND.	DVDD	Digital
7	DIN9	Parallel Data Input. Internal pulldown to GND.	DVDD	Digital

Pin Description (continued)

PIN	NAME	FUNCTION	REF SUPPLY	TYPE
19	PCLKIN	Parallel Clock Input with Internal Pulldown to GND. Latches parallel data inputs and provides the PLL reference clock.	DVDD	Digital
20	DIN0	Parallel Data Input. Internal pulldown to GND.	DVDD	Digital
21	DIN1	Parallel Data Input. Internal pulldown to GND.	DVDD	Digital
23	DIN2	Parallel Data Input. Internal pulldown to GND.	DVDD	Digital
24	DIN3	Parallel Data Input. Internal pulldown to GND.	DVDD	Digital
Multifunction				
8	DIN10/GPIO1	Parallel Data Input/GPIO. Defaults to parallel data input on power-up. Parallel data input has internal pulldown to GND. GPIO1 has an open-drain input/output with internal 60kΩ pullup to DVDD.	DVDD	Digital
9	DIN11/GPIO2	Parallel Data Input/GPIO. Defaults to parallel data input on power-up. Parallel data input has internal pulldown to GND. GPIO2 has an open-drain input/output with internal 60kΩ pullup to DVDD.	DVDD	Digital
10	DIN12/HS	Parallel Data Input/Horizontal Sync with Internal Pulldown to GND. Defaults to parallel data input on power-up. Defaults to horizontal-sync input when HS/VS encoding is enabled.	DVDD	Digital
11	DIN13/VS	Parallel Data Input/Vertical Sync with Internal Pulldown to GND. Defaults to parallel data input on power-up. Defaults to vertical-sync input when HS/VS encoding is enabled.	DVDD	Digital
Configuration and Interface				
12	GPO/HIM	General-Purpose Output/High-Immunity Mode Input with internal Pulldown to GND. HIM is latched at power-up and switches to GPO output automatically after power-up. Connect HIM to DVDD with a 30kΩ resistor to set high, or leave open to set low. HIGHIMM can be programmed to a different value after power-up. HIGHIMM in the deserializer must be set to the same value. GPO output follows the state of the GPI (or INT) input on the GMSL deserializer. GPO is low upon power-up.	DVDD	Digital
14	OUT-	Inverting Coax/Twisted-Pair Serial Output	—	Digital
15	OUT+	Noninverting Coax/Twisted-Pair Serial Output	—	Digital
17	SDA	Serial Data. Input/output with internal 30kΩ pullup to DVDD. SDA is the SDA input/output of the serializer's I ² C master/slave. SDA has an open-drain driver and requires a pullup resistor.	DVDD	Digital
18	SCL	Serial Clock Input/output with internal 30kΩ pullup to DVDD. SCL is the SCL input/output of the serializer's I ² C master/slave. SCL has an open-drain driver and requires a pullup resistor.	DVDD	Digital

Functional Block Diagram

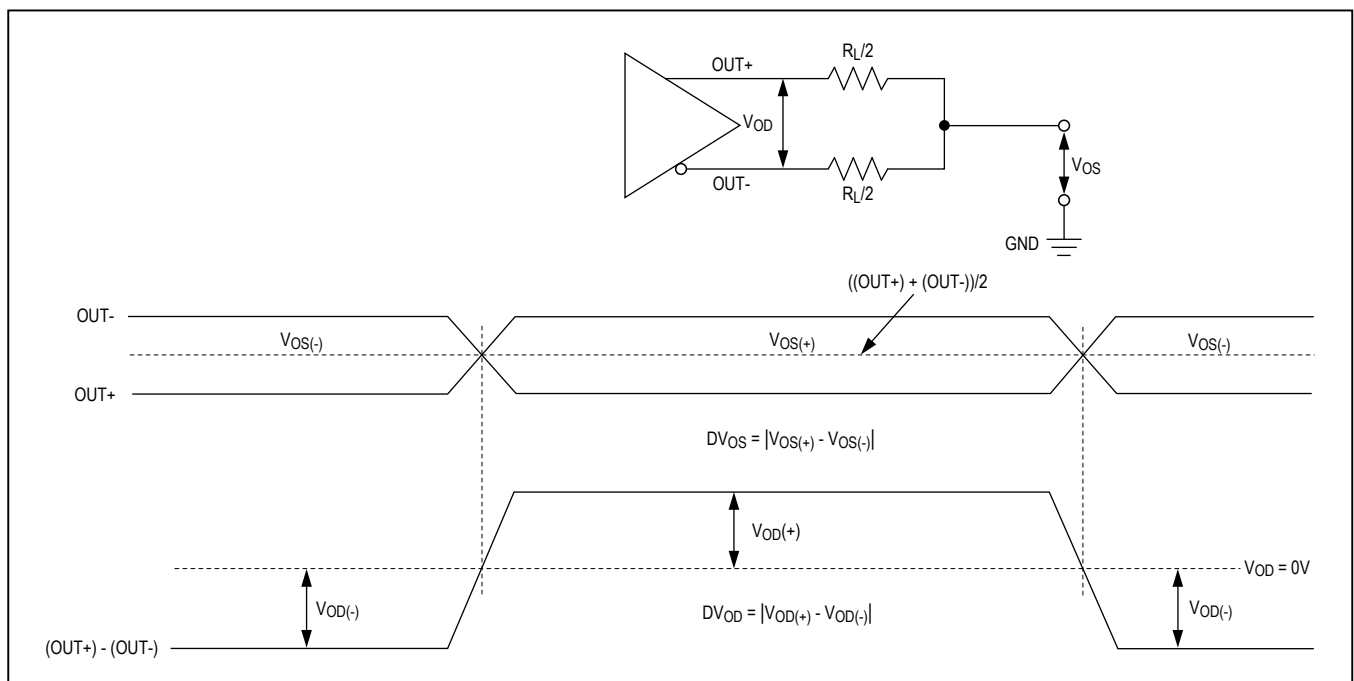
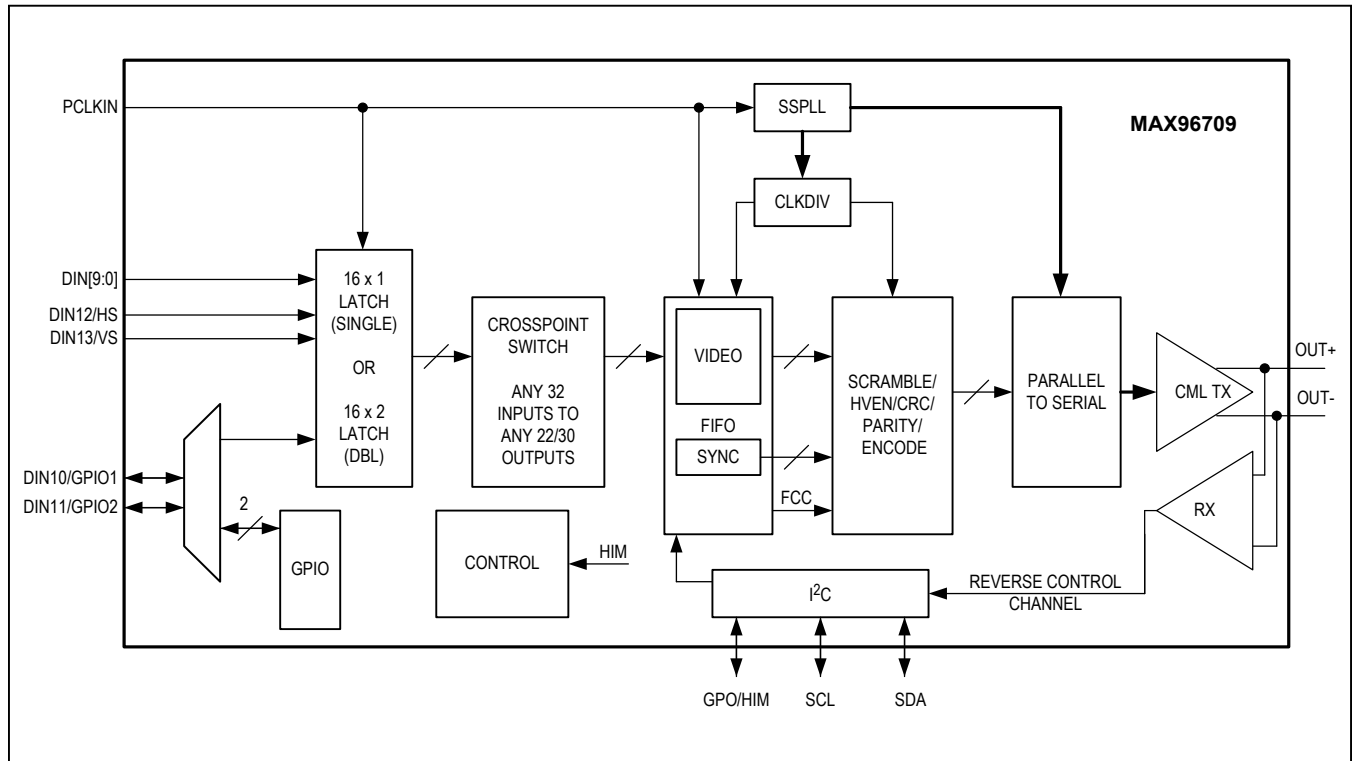

Figure 1. Serial-Output Parameters

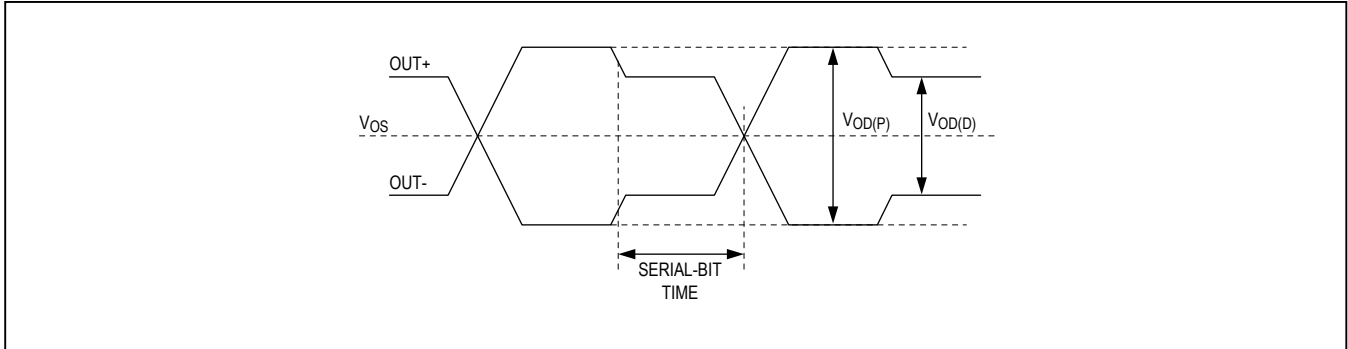

Figure 2. Output Waveforms at OUT+, OUT-

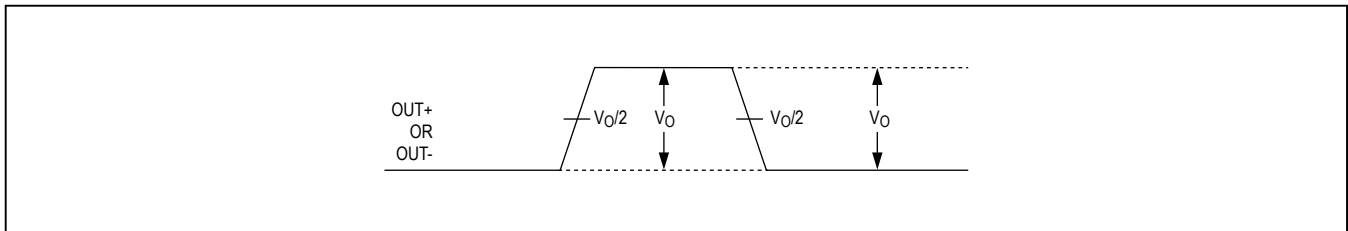

Figure 3. Single-Ended Output Template

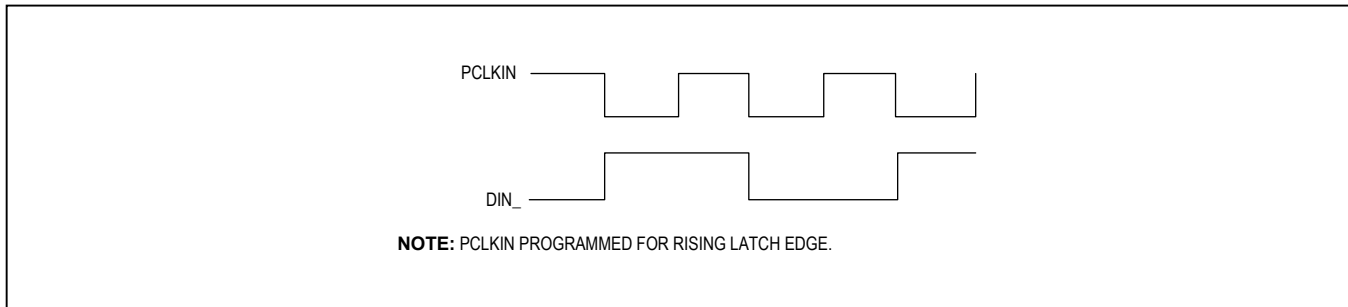

Figure 4. Worst-Case Pattern Input

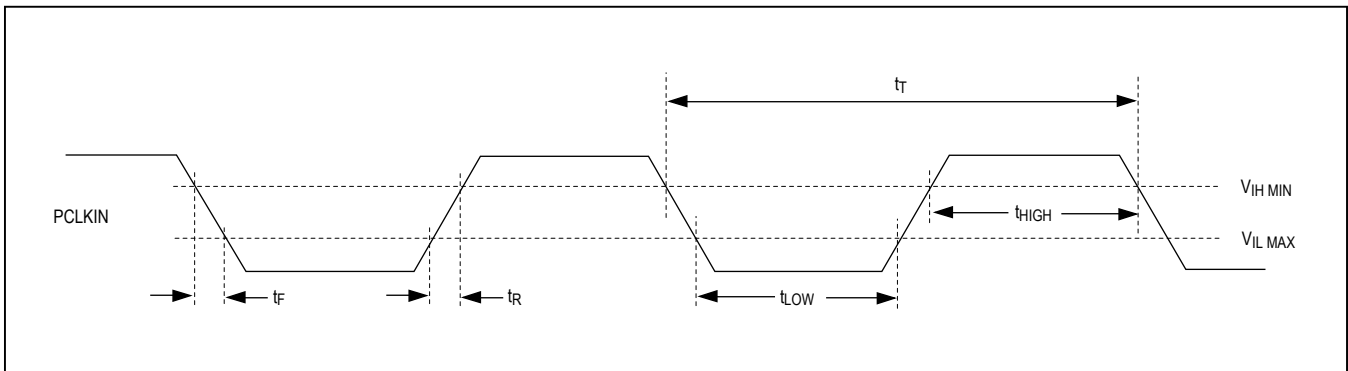

Figure 5. Parallel Clock Input Requirements

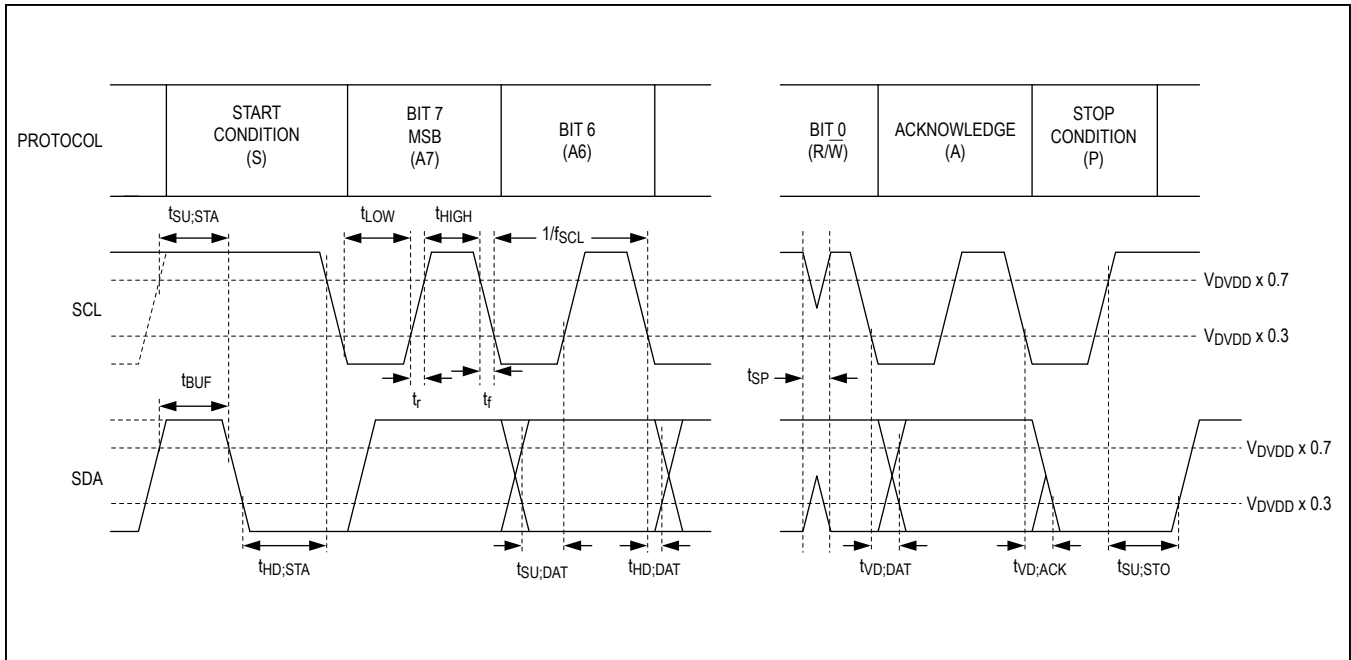

Figure 6. I²C Timing Parameters

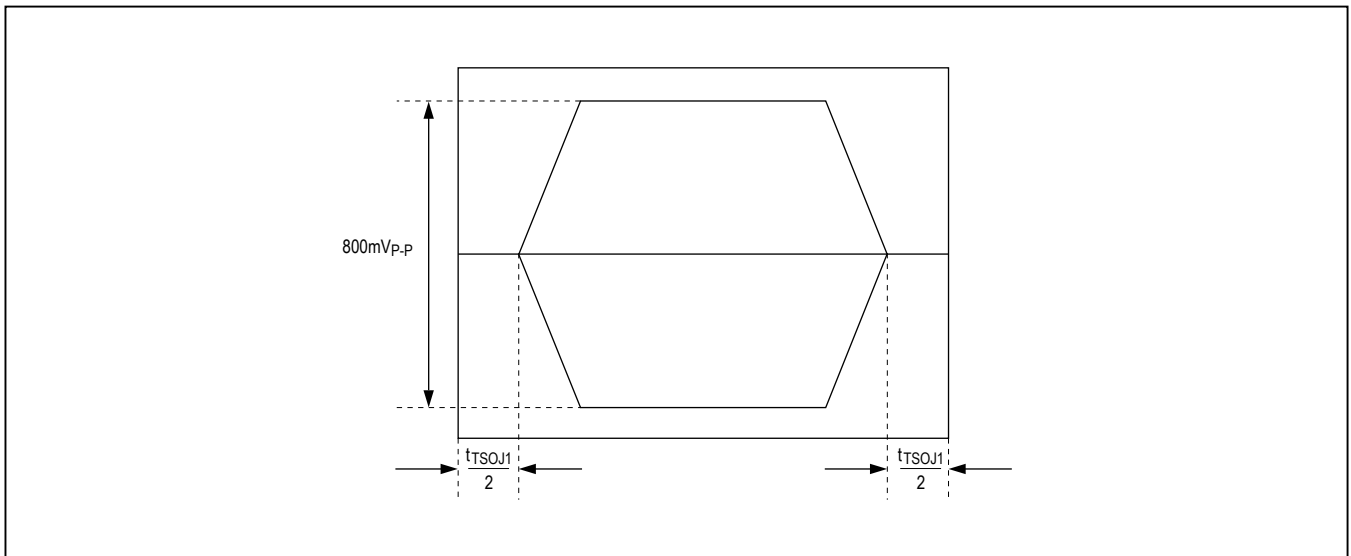

Figure 7. Differential Output Template

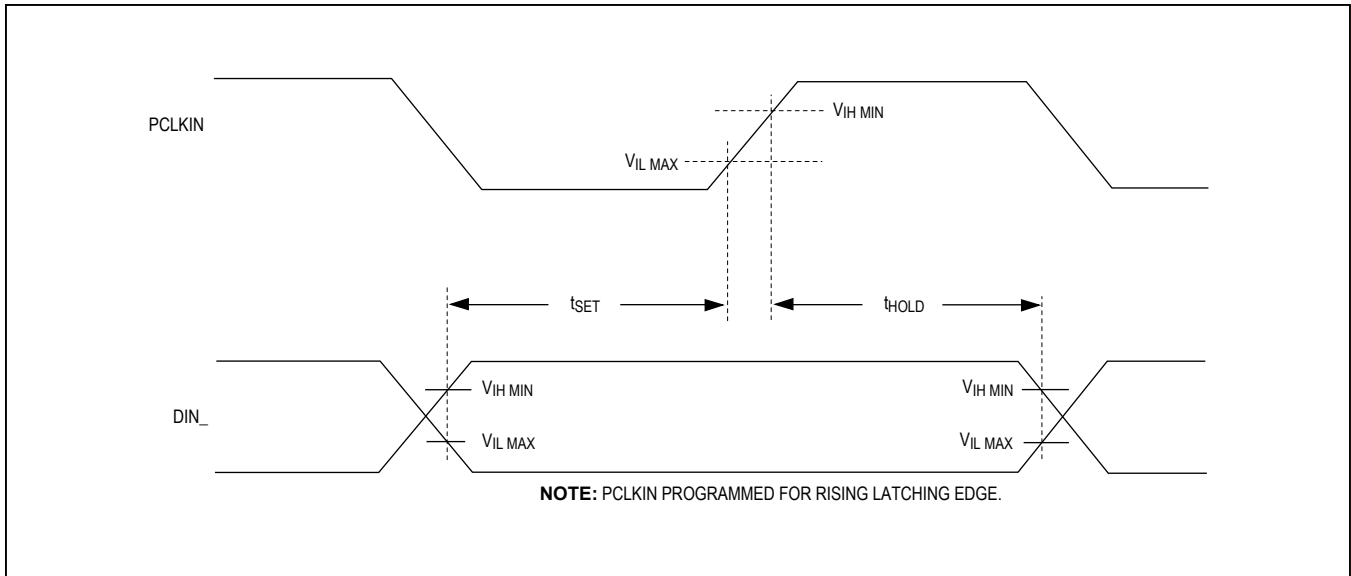

Figure 8. Input Setup and Hold Times

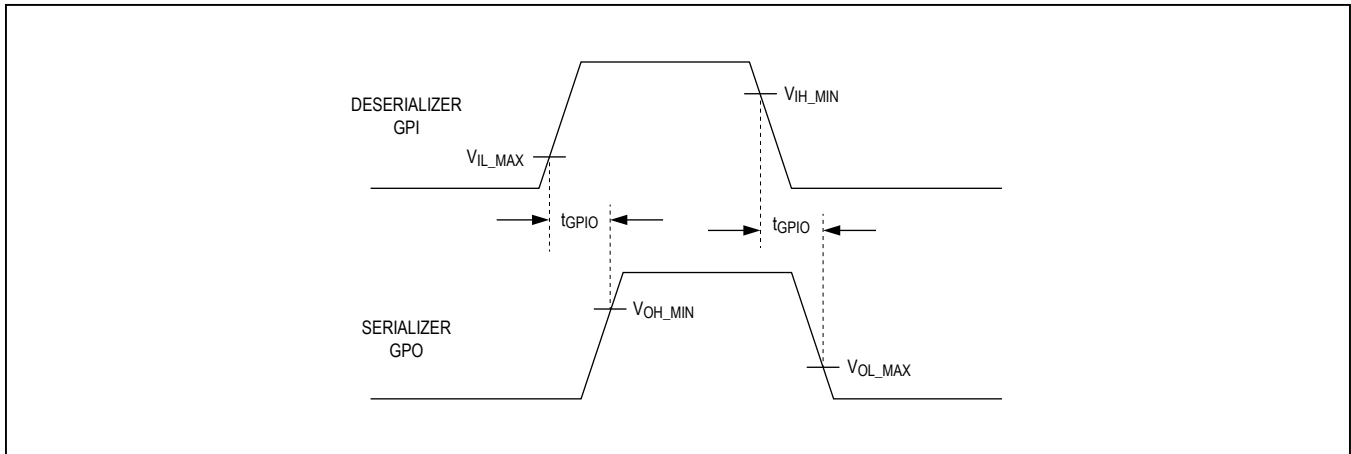

Figure 9. GPI-to-GPO Delay

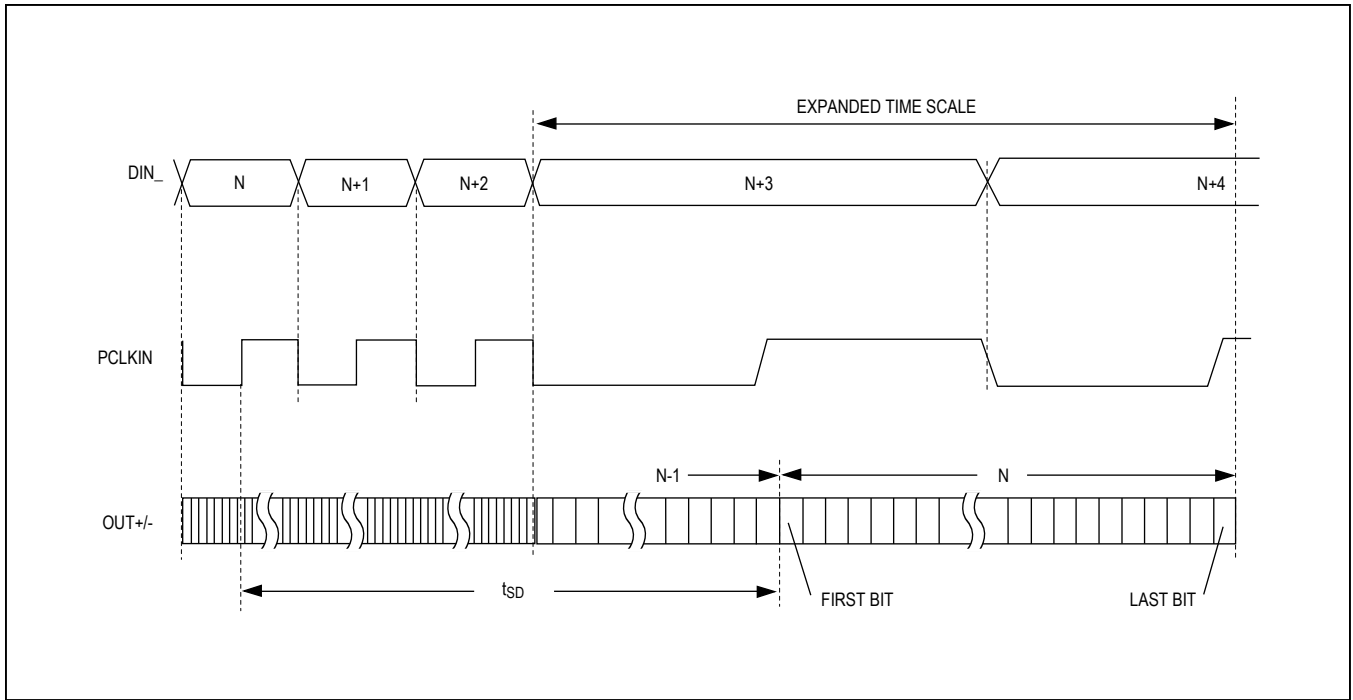

Figure 10. Serializer Delay

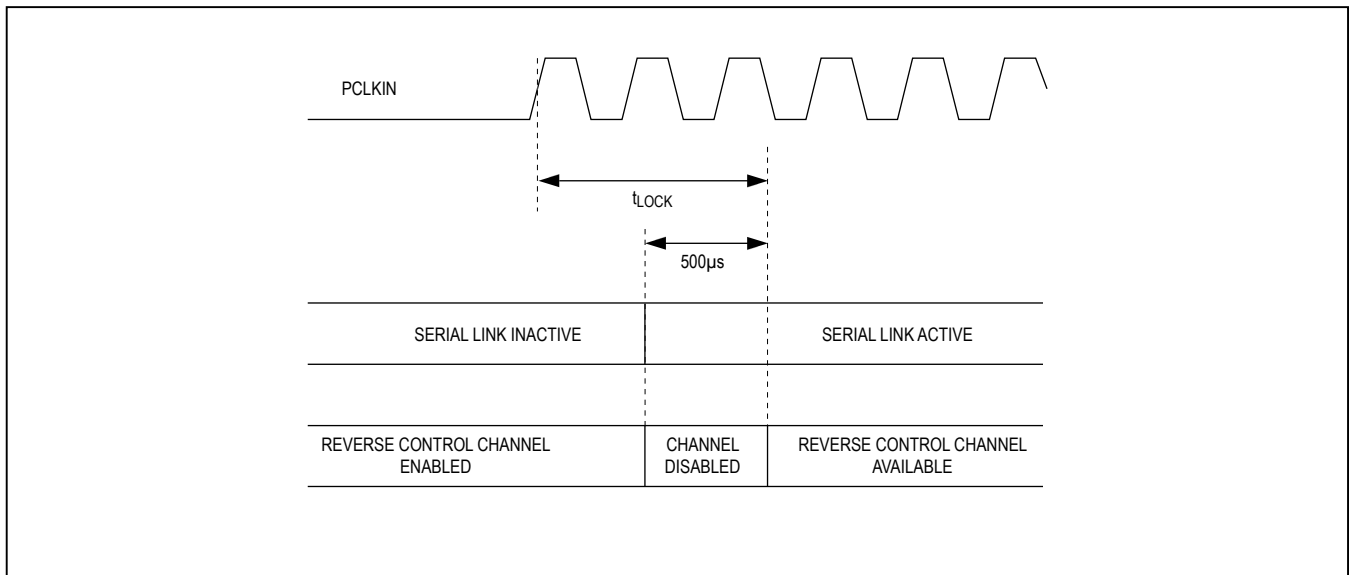

Figure 11. Link Startup Time

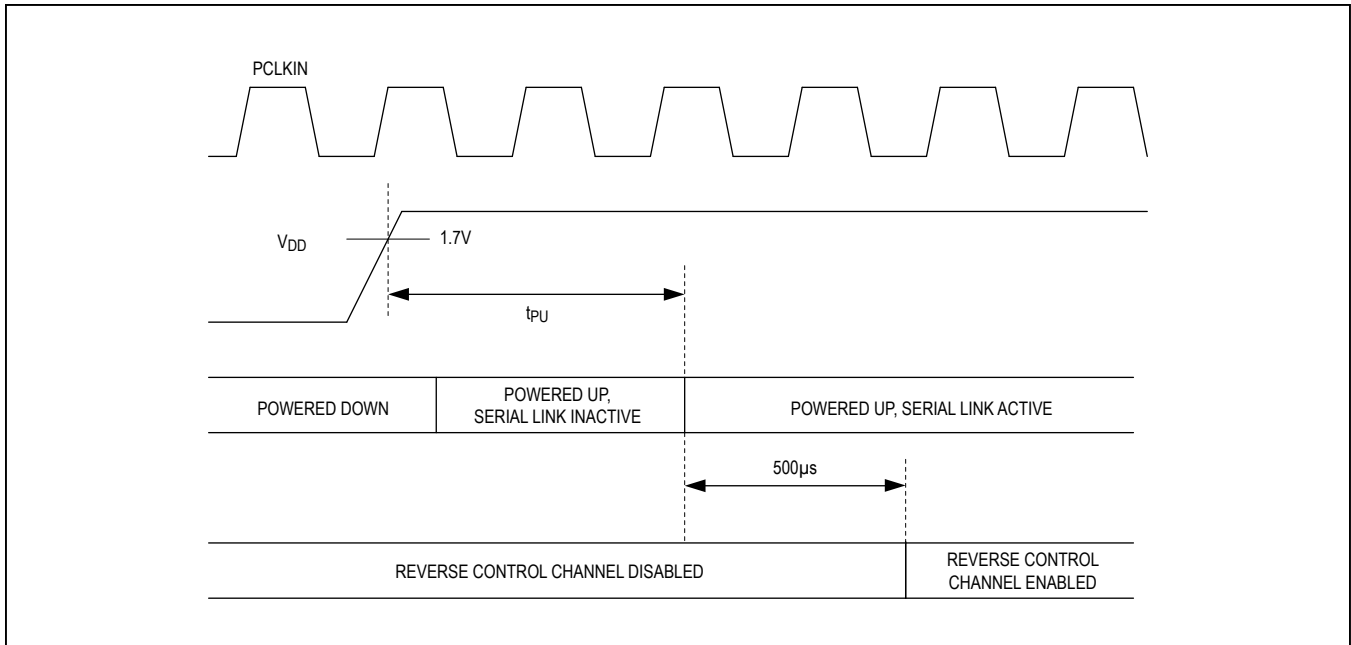

Figure 12. Power-Up Delay

Detailed Description

The MAX96709 is a compact device with features especially suited for automotive camera applications. The device operates at a variety of input widths and word rates up to a total serial-data rate up to 1.74Gbps. An embedded 9.6kbps to 1Mbps control channel programs the serializer, deserializer, and any attached I2C peripherals.

To promote safety applications, the device features CRC protection of video data. In addition, high-immunity mode reduces the effects of bit errors corrupting communication. Preemphasis and a PRBS tester allow for in-system evaluation and optimization of the link quality.

The MAX96709 operates over the -40°C to +115°C automotive temperature range.

Serial Link Signaling and Data Format

The serializer scrambles the input parallel data and combines this with the forward control data. The data is then encoded for transmission and output as a single-serialized bitstream at several times the input word rate (depending on bus width). The deserializer receives the serial data and recovers the clock signal. The data is then deserialized, decoded, and descrambled into parallel output data and forward control data.

Operating Modes

The GMSL devices are configurable to operate in many modes depending on the application. These modes allow for a more efficient use of serial bandwidth. Most of these settings are set during system design, and are configured through register bits.

Video/Configuration Link

In normal operation, the serializer runs in video link mode (serializer SEREN = 1) with video data and control data sent across the serial link. Set SEREN = 0 in the serializer to turn off serialization. The serializer powers up in video link mode and requires a valid PCLK for operation.

A configuration link is available to set up the serializer, deserializer, and peripherals when PCLK is not available. Set SEREN = 0 and CLINK = 1 in the serializer to enable the configuration link (SEREN = 1 forces the serializer into video link mode). Once PCLK has been established, turn on the video link (SEREN = 1).

By default, video link mode requires a valid PCLK for operation. Set AUTO_CLINK bit = 1 and SEREN = 1 in the serializer to have the device automatically switch between the video link and configuration link whenever PCLK is not present.

Single/Double Mode

Single-/double-mode operation configures the available 1.74Gbps bandwidth into a variety of widths and word rates. Single-mode operation is compatible with all GMSL devices and serializers, yielding one parallel word for each serial word. Double mode serializes two half-width parallel words for each serial word, resulting in a 2x increase in the parallel word rate range (compared to single mode). Set DBL = 0 for single-mode operation and DBL = 1 for double-mode operation.

HS/VS Encoding

By default, GMSL assigns a video bit slot to HSYNC, VSYNC, and DE (if used). With HS/VS encoding, the device instead encodes special packets to sync signals to free up additional video bit slots. Set HVEN = 1 to turn on HS/VS encoding (DE, if enabled, uses up a video bit). HS/VS encoding requires that HSYNC, VSYNC, and DE (if used) remain high during the active video and low during the blanking period. Use HS/VS inversion when using reverse-polarity sync signals.

Error Detection

The serial link's 8b/10b encoding/decoding and 1-bit parity detect bit errors that occur on the serial link. An optional 6-bit CRC check is available at the expense of 6 video bits. To activate 6-bit CRC mode, set PXL_CRC = 1 in the remote-side device first, then in the local-side device. When using 6-bit CRC mode, the available internal bus width is reduced by 6 bits in single-input mode (DBL = 0) and 3 bits in double-input mode (DBL = 1). Note that the input bus width may already have been reduced due to pin availability of the serializer or deserializer; thus, the reduction of bandwidth from CRC may not be visible (see [Table 3](#)).

Bus Widths

The serial link has multiple bus-width settings that determine the parallel bus width and the resulting parallel word rate. The serial link operates to a maximum serial bit rate of 1.74Gbps. The BWS bit determines if each serial packet is 30 or 40 bits long, which translates to a maximum serial packet rate (and resulting maximum parallel word rate) of 58MHz or 43.5MHz when BWS = 0 or 1 respectively. Encoding translates the 24, or 32 parallel bits into 30- or 40-bit serial packets. One bit is used for parity, while a second is reserved for the control channel. An additional 6 bits are used during optional 6-bit CRC. In addition, double mode splits the remaining word size in half, if used. The remaining bits can be used for video bits (minus any sync bits if H/V encoding is not used)

The following modes list the internal bus widths. The number of available input and output pins may limit the actual bus width available.

- **24-Bit Mode** ([Figure 13](#))

When BWS = 0, the 30-bit serial packet corresponds with three 8b/10b symbols representing 24 bits (24-bit mode). After the parity and control channel, this leaves 16/22 bits of video data if CRC is/or is not used (single mode), or 8/11 bits of video data if CRC is/or is not used (double mode).

- **32-Bit Mode** ([Figure 14](#))

When BWS = 1, the 40-bit serial packet corresponds with four 8b/10b symbols representing 32 bits (32-bit mode). After parity and control channel, this leaves 24/30 bits of video data if CRC is/or is not used (single mode), or 12/15 bits of video data if CRC is/or is not used (double mode).

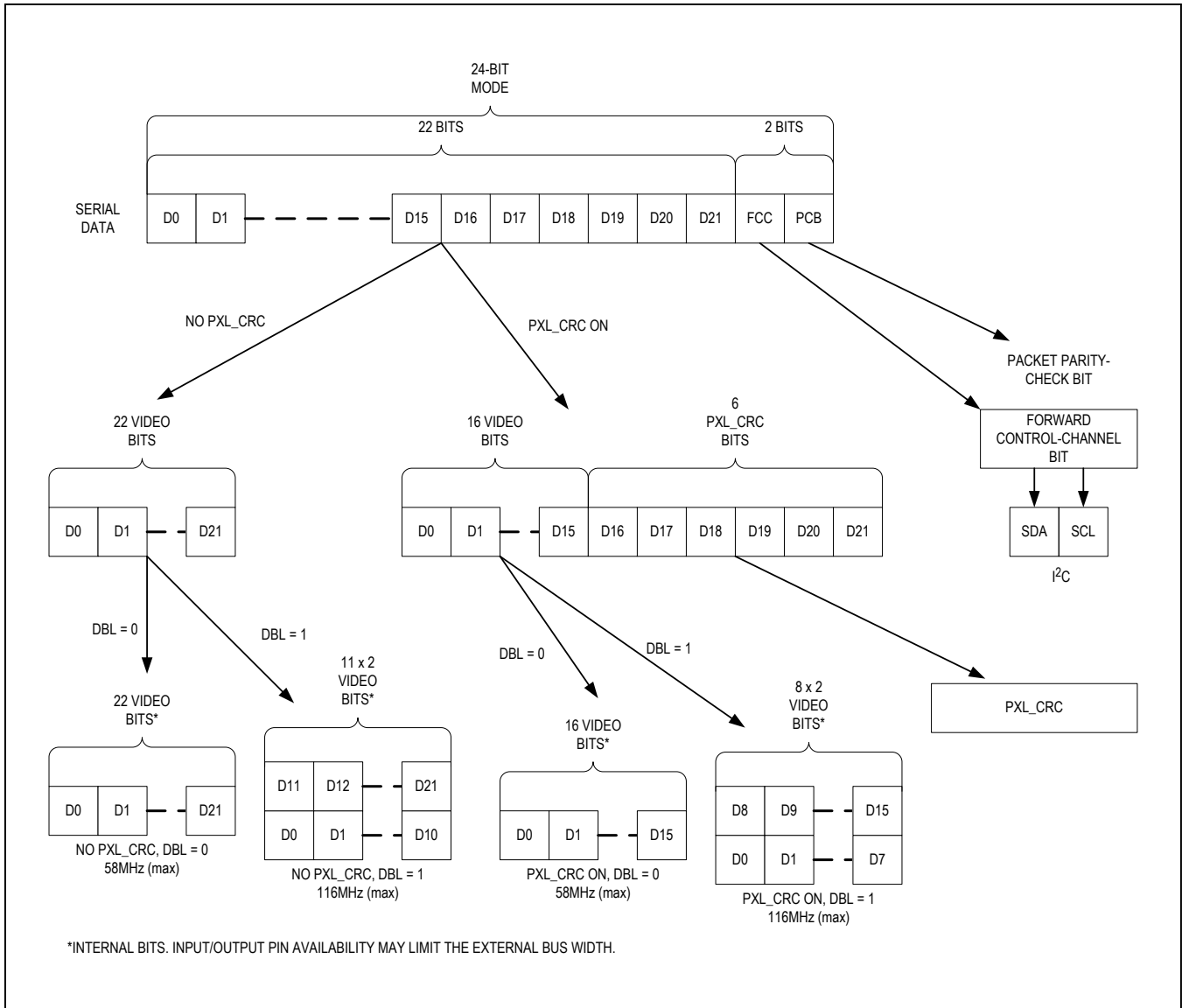

Figure 13. 24-Bit Mode Serial-Data Format

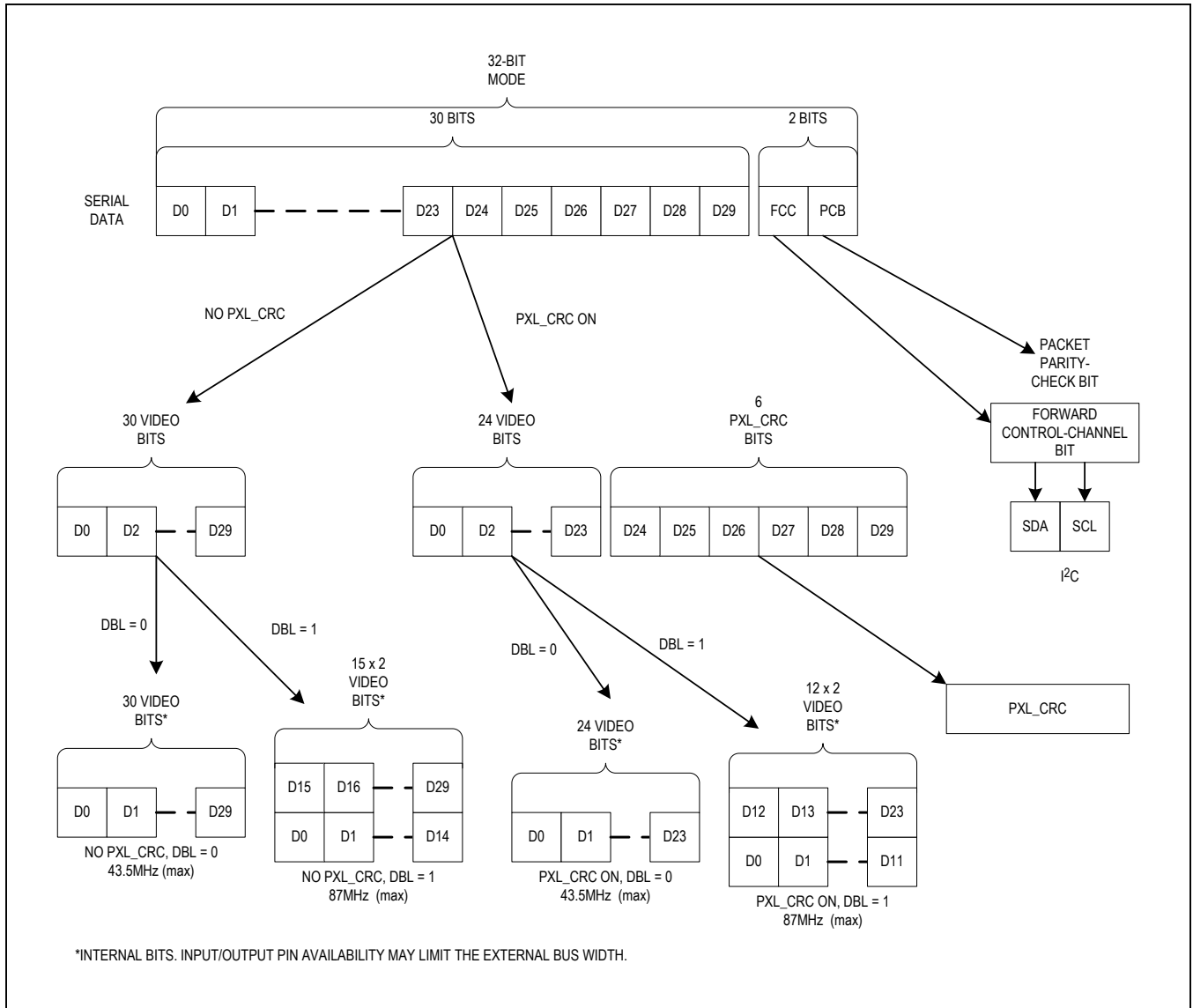

Figure 14. 32-Bit Mode Serial-Data Format

Control Channel and Register Programming

The control channel sends information across the serial link for control of the serializer, deserializer, and any attached peripherals. The control channel is multiplexed onto the serial link and is available with or without the video channel.

Forward Control Channel

Control data sent from the serializer to the deserializer is sent on the forward control channel. The data is encoded as one of the serial bits in the forward high-speed link. After deserialization, the forward control-channel data is extracted from the serial link. The forward control-channel bandwidth exceeds the maximum external control data rate, and all data sent on the forward control channel appears on the remote side after transmission delay of a few bit times.

Reverse Control Channel

Control data sent from the deserializer to the serializer is sent on the reverse control channel. The data is encoded as a series of 1 μ s pulses, with a maximum raw data rate of 1Mbps. High-immunity mode is available to increase the robustness of the reverse control channel at a reduced raw bit rate of 500kbps. In [Table 1](#), setting the REV_FAST bit = 1 increases this rate back to 1Mbps. When the input data rate (after encoding) exceeds the reverse data rate, the input clock is held through clock stretching to slow the external clock to match the internal bit rate.

I²C Interface

The serial link connects the serializer and deserializer (SerDes) I²C interfaces together through the control channel. When an I²C master sends a command to one side of the link (local side) the control channel forwards this infor-

mation to and from the other side of the link (remote side), allowing a single microcontroller to configure the serializer, deserializer, and peripherals. The microcontroller can be located on the serializer side (display applications) and the deserializer side (camera applications). Dual microcontroller operations are supported as long as a software-arbitration method is used. The serial link assumes that only one microcontroller is talking at any given time.

Remote-End Operation

When an I²C master initiates communication on the local slave device (the SerDes directly connected to the master), the remote-side device acts as a master device that sends data forwarded from the local-side device, and forwards any data received from peripherals attached to the remote-side device. This remote-side master device operates according to the timing settings in the I²C master setting register. Set the master settings to match the timing settings used by the external microcontroller.

Clock-Stretch Timing

The I²C interface uses clock stretching to allow time for data to be forwarded across the serial link. The master microcontroller, along with any attached peripherals, must accept clock stretching of the GMSL devices.

GPO/GPI Control

GPO on the serializer follows GPI transitions on the deserializer. This GPO/GPI function can be used to transmit signals such as a frame sync in a surround-view camera system (see the [Providing a Frame Sync \(Camera Applications\)](#) section). Optionally, GPO can be set directly by register bits.

Table 1. Reverse Control-Channel Modes

HIM PIN SETTING	REVFASST BIT	REVERSE CONTROL-CHANNEL MODE	MAXIMUM I ² C BIT RATE (KBPS)
Low	X	Legacy reverse control-channel mode (compatible with all GMSL devices)	1000
High	0	High-immunity mode	500
	1	Fast high-immunity mode (requires serial-data rate > 1.25Gbps)	1000

X = Don't care.

Spread Spectrum

The serializer contains a programmable spread-spectrum output to lower emission levels by spreading the clock-frequency peaks across a frequency spectrum. In addition, the SerDes can track a spread input clock, eliminating the need for multiple spread clocks.

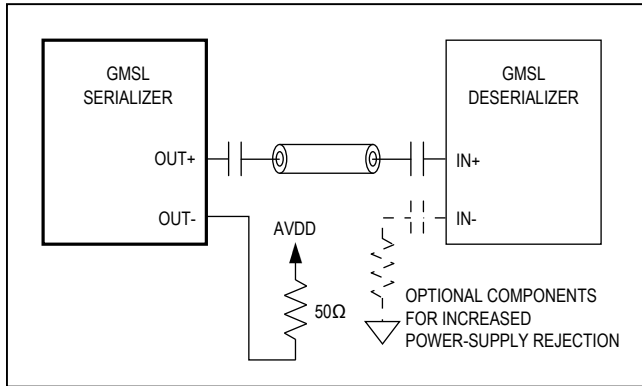

Figure 15. Coax Connection

Cable Type Configuration

The driver output is programmable for two kinds of cable, 100Ω twisted pair and 50Ω coax (contact the factory for devices compatible with 75Ω cables). In coax mode, connect OUT+ to IN+ of the deserializer. Leave the unused IN_ pin unconnected, or connect it to ground through 50Ω, and a capacitor for increased power-supply rejection. Connect OUT- to V_{DD} through a 50Ω resistor (Figure 15).

Crossbar Switch

The crossbar switch routes data between the parallel input/output and the SerDes. The anything-to-anything routing assures the mapping between the video source and destination. For each crossbar output (XBO_) an input multiplexer selects from the available crossbar inputs (XBI_) using the CROSSBAR_ register bits (Figure 16). Multiple crossbar outputs can use the same crossbar input. By default, the sync signals share the same inputs as the MSBs of the video data.

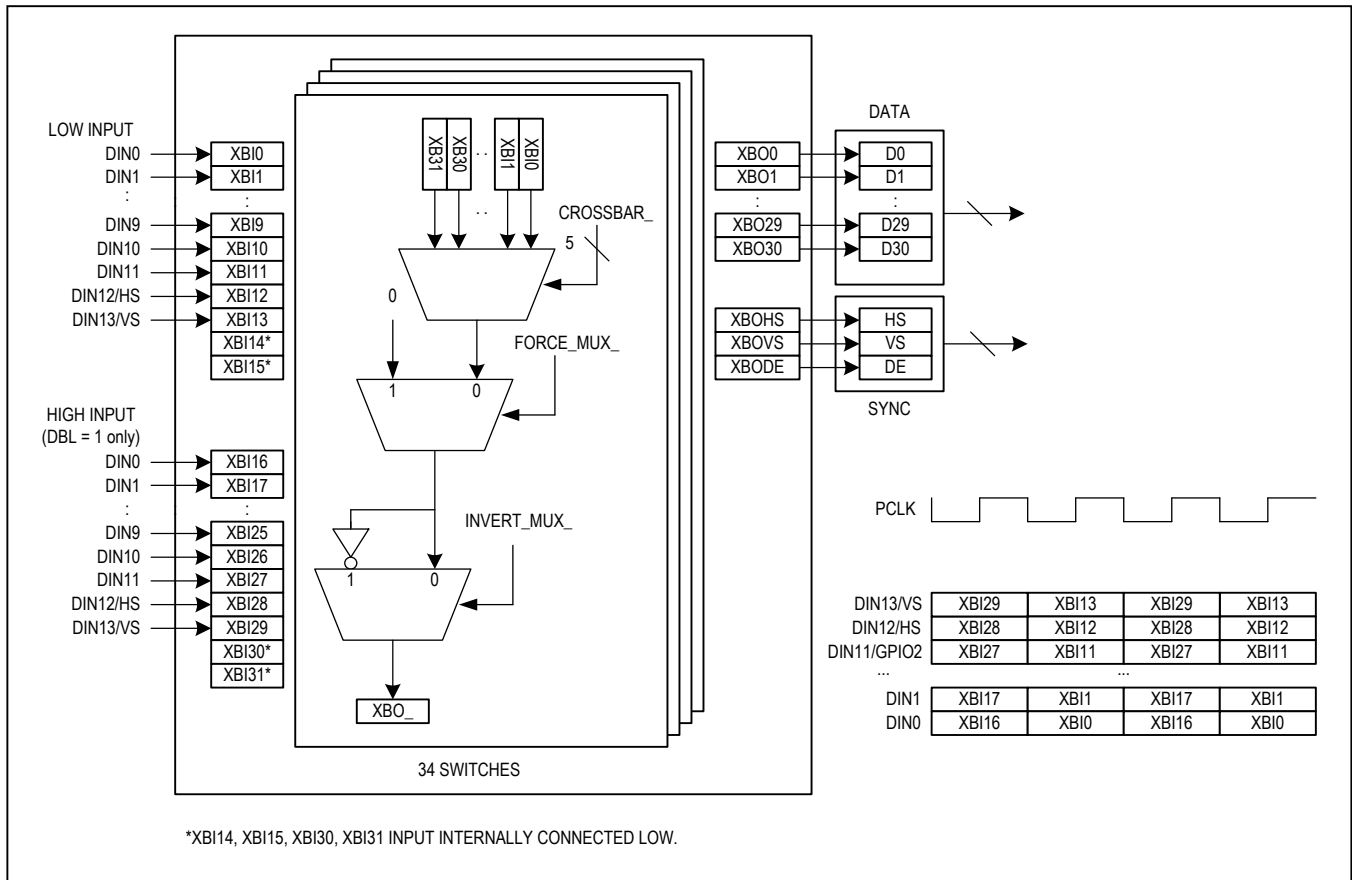

Figure 16. Crossbar-Switch Dataflow

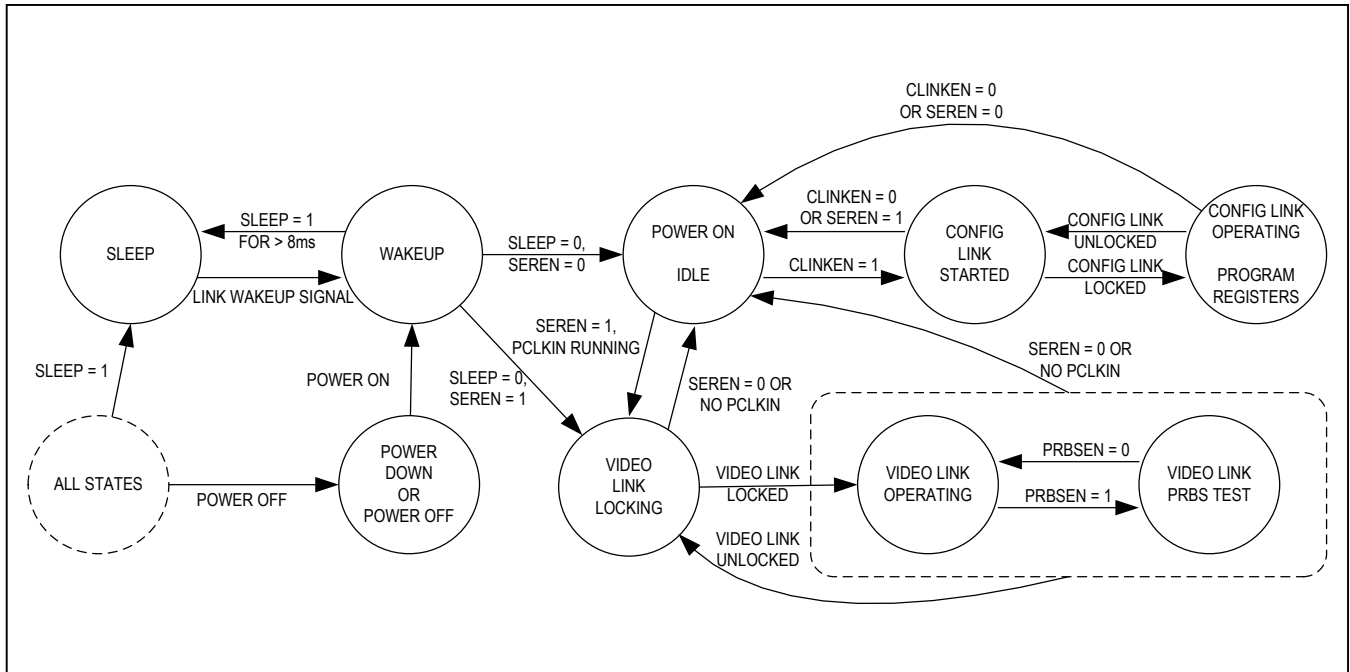

Figure 17. State Diagram

Shutdown/Sleep Modes

Several sleep and shutdown modes are available when full operation is not needed.

Configuration Link

When the high-speed video link is not needed, or unavailable, a configuration link can be used in its place. In configuration link mode, the parallel digital input/output is disabled, the LOCK pin remains low, and the serial link internally generates its own clock to allow full operation of the control channel (I2C and GPIO).

Serialization Disable

When the serial link is not needed, such as when downstream devices are powered off, the user can disable

serialization. In this mode, all forward communication is shut down. The user can reenale serialization either locally, or through the reverse channel.

Sleep Mode

To reduce power consumption further, the devices can be put into sleep mode. In this mode, all registers keep their programmed values, and all functions in the device are powered down except for the wake-up detectors on the local control interface, and the serial link. Any activity seen by the wake-up detectors temporarily turns on the control-channel interface. During this time, a microcontroller can command the device to exit sleep mode. See the [Shutdown/Sleep Modes](#) section.

Link Startup Procedure

[Table 2](#) lists the startup procedure for image-sensing applications. The control channel is available after the

video link or the configuration link is established. If the deserializer powers up after the serializer, the control channel becomes unavailable until 2ms after power-up.

Table 2. Link-Startup Procedure

NO.	μC	SERIALIZER	DESERIALIZER
—	μC Connected to Deserializer	Set Configuration Inputs	Set Configuration Inputs
1	Powers up (wait t_{PU}).	Powers up and loads default settings. Establishes video link when valid PCLK is available.	Powers up and loads default settings. Locks to video link signal if available.
1a	If no PCLK, programs CLINKEN, SEREN, and/or AUTOCLINK bits. Wait 5ms after each command.	Establishes configuration link.	Locks to configuration link if available.
1b	If not locked, sets any additional configuration bits that are mismatched between the serializer and deserializer (e.g., BWS, CX/TP). Wait 5ms for lock after each command.	Configuration changed. Reestablishes configuration/video link if needed.	Configuration changed. Locks to configuration/video link.
2	Sets register 0x07 configuration bits in the serializer (DBL, BWS, PXL_CRC, etc.). Wait 2ms.	Configuration changed. Reestablishes configuration/video link if needed.	Loss-of-lock may occur.
3	Sets register 0x07 configuration bits in the deserializer (DBL, BWS, PXL_CRC, etc.). Wait 5ms for lock to reestablish.	—	Configuration changed. Locks to configuration/video link.
4	Writes rest of serializer/deserializer configuration bits.	Configuration changed.	Configuration changed.
5	Writes camera/peripheral configuration bits.	Forwards commands from μC to serializer.	Forwards commands to camera/peripherals.
5a	If in configuration link, when PCLK is available, set SEREN = 1. Wait 5ms for lock.	Enables video link.	Locks to video link.

Register Map

GMSL Register Map

OFFSET	NAME	MSB							LSB
0x00	seraddr	SERADDR[6:0]							CFG-BLOCK
0x01	desaddr	DESADDR[6:0]							RSVD
0x02	ss	SS[2:0]			RSVD	PRNG[1:0]		SRNG[1:0]	
0x03	sdiv	AUTOFM[1:0]			SDIV[5:0]				
0x04	main_control	SEREN	CLINKEN	PRBSEN	SLEEP	RSVD[1:0]		REVCEN	FWDCEN
0x05	prbs_len	RSVD	RSVD	PRBS_LEN[1:0]		RSVD	RSVD	RSVD	RSVD
0x06	cmlvl_preemp	CMLLVL[3:0]				PREEMP[3:0]			
0x07	config	DBL	RSVD	BWS	ES	RSVD	HVEN	RSVD	PXL_CRC
0x08	rsvd_8	RSVD	RSVD	RSVD	RSVD	RSVD	RSVD	RSVD	RSVD
0x09	i2c_source A	I2C_SRC_A[6:0]							RSVD
0x0A	i2c_dest A	I2C_DST_A[6:0]							RSVD
0x0B	i2c_source B	I2C_SRC_B[6:0]							RSVD
0x0C	i2c_dest B	I2C_DST_B[6:0]							RSVD
0x0D	i2c_config	I2C_LOC_ACK	I2C_SLV_SH[1:0]		I2C_MST_BT[2:0]			I2C_SLV_TO[1:0]	
0x0E	gpio_en	RSVD	RSVD	RSVD	RSVD	RSVD	GPIO_EN_2	GPIO_EN_1	RSVD
0x0F	gpio_out	EN_SET_GPO	RSVD	RSVD	RSVD	RSVD	GPIO_OUT_2	GPIO_OUT_1	SET_GPO
0x10	gpio_in	RSVD	RSVD	RSVD	RSVD	RSVD	GPIO_IN_2	GPIO_IN_1	GPO_L
0x11	errg	ERRG_RATE[1:0]		ERRG_TYPE[1:0]		ERRG_CNT[1:0]		ERRG_PER	ERRG_EN
0x12	rsvd_12	RSVD	RSVD	RSVD	RSVD[4:0]				
0x13	pd	SOFT_PD	RSVD	RSVD	RSVD	RSVD	RSVD	RSVD[1:0]	
0x14	rsvd_14	RSVD[1:0]		RSVD	RSVD	RSVD	RSVD	RSVD	RSVD
0x15	input_status	RSVD	RSVD	RSVD	RSVD	RSVD	RSVD	OUT-PUTEN	PCLKDET
0x16	rsvd_16	RSVD	RSVD	RSVD[5:0]					
0x17	rsvd_17	RSVD[7:0]							
0x18	rsvd_18	RSVD[7:0]							
0x19	rsvd_19	RSVD[7:0]							
0x1A	rsvd_1A	RSVD[7:0]							
0x1B	rsvd_1B	RSVD[7:0]							
0x1C	rsvd_1C	RSVD[7:0]							
0x1D	rsvd_1D	RSVD[7:0]							
0x1E	id	ID[7:0]							
0x1F	revision	RSVD	RSVD	RSVD	HDCPCAP	REVISION[3:0]			

GMSL Register Map (continued)

OFFSET	NAME	MSB				LSB
0x20	crossbar 0	RSVD	FORCE_MUX_0	INVERT_MUX_0		CROSSBAR_0[4:0]
0x21	crossbar 1	RSVD	FORCE_MUX_1	INVERT_MUX_1		CROSSBAR_1[4:0]
0x22	crossbar 2	RSVD	FORCE_MUX_2	INVERT_MUX_2		CROSSBAR_2[4:0]
0x23	crossbar 3	RSVD	FORCE_MUX_3	INVERT_MUX_3		CROSSBAR_3[4:0]
0x24	crossbar 4	RSVD	FORCE_MUX_4	INVERT_MUX_4		CROSSBAR_4[4:0]
0x25	crossbar 5	RSVD	FORCE_MUX_5	INVERT_MUX_5		CROSSBAR_5[4:0]
0x26	crossbar 6	RSVD	FORCE_MUX_6	INVERT_MUX_6		CROSSBAR_6[4:0]
0x27	crossbar 7	RSVD	FORCE_MUX_7	INVERT_MUX_7		CROSSBAR_7[4:0]
0x28	crossbar 8	RSVD	FORCE_MUX_8	INVERT_MUX_8		CROSSBAR_8[4:0]
0x29	crossbar 9	RSVD	FORCE_MUX_9	INVERT_MUX_9		CROSSBAR_9[4:0]
0x2A	crossbar 10	RSVD	FORCE_MUX_10	INVERT_MUX_10		CROSSBAR_10[4:0]
0x2B	crossbar 11	RSVD	FORCE_MUX_11	INVERT_MUX_11		CROSSBAR_11[4:0]
0x2C	crossbar 12	RSVD	FORCE_MUX_12	INVERT_MUX_12		CROSSBAR_12[4:0]
0x2D	crossbar 13	RSVD	FORCE_MUX_13	INVERT_MUX_13		CROSSBAR_13[4:0]
0x2E	crossbar 14	RSVD	FORCE_MUX_14	INVERT_MUX_14		CROSSBAR_14[4:0]
0x2F	crossbar 15	RSVD	FORCE_MUX_15	INVERT_MUX_15		CROSSBAR_15[4:0]
0x30	crossbar 16	RSVD	FORCE_MUX_16	INVERT_MUX_16		CROSSBAR_16[4:0]
0x31	crossbar 17	RSVD	FORCE_MUX_17	INVERT_MUX_17		CROSSBAR_17[4:0]
0x32	crossbar 18	RSVD	FORCE_MUX_18	INVERT_MUX_18		CROSSBAR_18[4:0]
0x33	crossbar 19	RSVD	FORCE_MUX_19	INVERT_MUX_19		CROSSBAR_19[4:0]
0x34	crossbar 20	RSVD	FORCE_MUX_20	INVERT_MUX_20		CROSSBAR_20[4:0]

GMSL Register Map (continued)

OFFSET	NAME	MSB							LSB
0x35	crossbar 21	RSVD	FORCE_MUX_21	INVERT_MUX_21	CROSSBAR_21[4:0]				
0x36	crossbar 22	RSVD	FORCE_MUX_22	INVERT_MUX_22	CROSSBAR_22[4:0]				
0x37	crossbar 23	RSVD	FORCE_MUX_23	INVERT_MUX_23	CROSSBAR_23[4:0]				
0x38	crossbar 24	RSVD	FORCE_MUX_24	INVERT_MUX_24	CROSSBAR_24[4:0]				
0x39	crossbar 25	RSVD	FORCE_MUX_25	INVERT_MUX_25	CROSSBAR_25[4:0]				
0x3A	crossbar 26	RSVD	FORCE_MUX_26	INVERT_MUX_26	CROSSBAR_26[4:0]				
0x3B	crossbar 27	RSVD	FORCE_MUX_27	INVERT_MUX_27	CROSSBAR_27[4:0]				
0x3C	crossbar 28	RSVD	FORCE_MUX_28	INVERT_MUX_28	CROSSBAR_28[4:0]				
0x3D	crossbar 29	RSVD	FORCE_MUX_29	INVERT_MUX_29	CROSSBAR_29[4:0]				
0x3E	crossbar 30	RSVD	FORCE_MUX_30	INVERT_MUX_30	CROSSBAR_30[4:0]				
0x3F	crossbar_hs	RSVD	FORCE_MUX_HS	INVERT_MUX_HS	CROSSBARHS[4:0]				
0x40	crossbar_vs	RSVD	FORCE_MUX_VS	INVERT_MUX_VS	CROSSBARVS[4:0]				
0x41	crossbar_de	RSVD	FORCE_MUX_DE	INVERT_MUX_DE	CROSSBARDE[4:0]				
0x42	link_config	RSVD[1:0]		RSVD	RSVD	RSVD	RSVD	RSVD	GPO_EN
0x43	rsvd_43	RSVD	RSVD	RSVD	RSVD	RSVD	RSVD	RSVD[1:0]	
0x44	rsvd_44	RSVD[7:0]							
0x45	rsvd_45	RSVD[7:0]							
0x46	rsvd_46	RSVD[7:0]							
0x47	rsvd_47	RSVD[7:0]							
0x48	rsvd_48	RSVD[7:0]							
0x49	rsvd_49	RSVD[7:0]							
0x4A	rsvd_4A	RSVD[7:0]							
0x4B	rsvd_4B	RSVD[7:0]							
0x4C	rsvd_4C	RSVD[7:0]							
0x4D	cxtp	RSVD	CXTP	RSVD	RSVD	RSVD	RSVD	RSVD	RSVD
0x4E	rsvd_4E	RSVD[7:0]							
0x4F	rsvd_4F	RSVD[7:0]							

GMSL Register Map (continued)

OFFSET	NAME	MSB							LSB
0x50	rsvd_50	RSVD[7:0]							
0x51	rsvd_51	RSVD[7:0]							
0x52	rsvd_52	RSVD[7:0]							
0x53	rsvd_53	RSVD[7:0]							
0x54	rsvd_54	RSVD[7:0]							
0x55	rsvd_55	RSVD[7:0]							
0x56	rsvd_56	RSVD[7:0]							
0x57	rsvd_57	RSVD[7:0]							
0x58	rsvd_58	RSVD[7:0]							
0x59	rsvd_59	RSVD[7:0]							
0x5A	rsvd_5A	RSVD[7:0]							
0x5B	rsvd_5B	RSVD[7:0]							
0x5C	rsvd_5C	RSVD[7:0]							
0x5D	rsvd_5D	RSVD[7:0]							
0x5E	rsvd_5E	RSVD[7:0]							
0x5F	rsvd_5F	RSVD[7:0]							
0x60	rsvd_60	RSVD[7:0]							
0x61	rsvd_61	RSVD[7:0]							
0x62	rsvd_62	RSVD[7:0]							
0x63	rsvd_63	RSVD[7:0]							
0x64	rsvd_64	RSVD[7:0]							
0x65	rsvd_65	RSVD[7:0]							
0x66	prbs_type	RSVD[1:0]	PRBS_TYPE	REV_FAST	RSVD	DIS_WAKE	RSVD	CXSEL	
0x67	auto_clink	RSVD[1:0]	AUTO_CLINK	RSVD	RSVD	RSVD[2:0]			
0x68	rsvd_68	RSVD	RSVD[2:0]		RSVD[1:0]		RSVD[1:0]		
0x69	rsvd_69	RSVD	RSVD	RSVD	RSVD[4:0]				
0x96	rsvd_96	RSVD	RSVD	RSVD	RSVD	RSVD	RSVD	RSVD[1:0]	
0x97	rsvd_97	RSVD	RSVD	RSVD	RSVD	RSVD	RSVD[2:0]		
0x98	rsvd_98	RSVD[1:0]		RSVD[2:0]			RSVD[2:0]		
0x99	rsvd_99	RSVD	RSVD	RSVD	RSVD	RSVD	RSVD	RSVD[1:0]	
0x9A	rsvd_9A	RSVD[1:0]		RSVD[1:0]		RSVD	RSVD[1:0]		RSVD
0xC8	rsvd_c8	RSVD	RSVD	RSVD	RSVD	RSVD	RSVD	RSVD	RSVD

GMSL Register Map (continued)

OFFSET	NAME	MSB							LSB
0xC9	rsvd_c9	RSVD[7:0]							
0xFC	rsvd_fc	RSVD	RSVD	RSVD	RSVD	RSVD	RSVD	RSVD	RSVD
0xFD	rsvd_fd	RSVD[7:0]							
0xFE	rsvd_fe	RSVD[3:0]				RSVD[3:0]			
0xFF	rsvd_ff	RSVD	RSVD	RSVD	RSVD	RSVD[3:0]			

seraddr (0x00)

BIT	7	6	5	4	3	2	1	0
Field	SERADDR[6:0]							CFGBLOCK
Reset	1000000b							0b
Access Type	Write, Read							Write, Read

BITFIELD	BITS	DESCRIPTION	DECODE
SERADDR	7:1	Serializer Address: Serializer device address	0000000: Write/read device address is 0x00/0x01 0000001: Write/read device address is 0x02/0x03 1111111: Write/read device address is 0xFE/0xFF
CFG-BLOCK	0	Configuration Block: Set to 1 to make all registers read-only. Power-on reset to clear this bit.	0: Make all registers read/write 1: Make all registers read-only

desaddr (0x01)

BIT	7	6	5	4	3	2	1	0
Field	DESADDR[6:0]							RSVD
Reset	1001000b							0b
Access Type	Write, Read							Write, Read

BITFIELD	BITS	DESCRIPTION	DECODE
DESADDR	7:1	Deserializer Address: Deserializer device address	0000000: Write/read device address is 0x00/0x01 0000001: Write/read device address is 0x02/0x03 1111111: Write/read device address is 0xFE/0xFF
RSVD	0	Reserved: Do not change from default value	0: Reserved

ss (0x02)

BIT	7	6	5	4	3	2	1	0
Field	SS[2:0]			RSVD	PRNG[1:0]		SRNG[1:0]	
Reset	000b			1b	11b		11b	
Access Type	Write, Read			Write, Read	Write, Read		Write, Read	

BITFIELD	BITS	DESCRIPTION	DECODE
SS	7:5	Spread Spectrum: Spread-spectrum setting	000: Spread is off 001: 0.5% Spread setting 010: 1.5% Spread setting 011: 2% Spread setting 100: Spread is off 101: 1% Spread setting 110: 3% Spread setting 111: 4% Spread setting
RSVD	4	Reserved: Do not change from default value	1: Reserved
PRNG	3:2	Pixel Clock Range: Pixel clock-range selection Stated ranges depend on DBL = setting	00: Select 12.5MHz to 25MHz (DBL = 0) or 25MHz to 50MHz (DBL = 1) pixel clock range 01: Select 25MHz to 58MHz (DBL = 0) or 50MHz to 116MHz (DBL = 1) pixel clock range 10: Automatically detect pixel clock range 11: Automatically detect pixel clock range.
SRNG	1:0	Serial-Data Rate Range	00: 0.5Gbps to 1Gbps serial-data range 01: 1Gbps to 1.74Gbps serial-data range 10: Automatically detect serial-data range 11: Automatically detect serial-data range

sdiv (0x03)

BIT	7	6	5	4	3	2	1	0
Field	AUTOFM[1:0]			SDIV[5:0]				
Reset	00b			000000b				
Access Type	Write, Read			Write, Read				

BITFIELD	BITS	DESCRIPTION	DECODE
AUTOFM	7:6	Automatic Frequency Modulation: Modulation-rate calibration interval	00: Calibration occurs once 01: Calibration occurs every 2ms 10: Calibration occurs every 16ms 11: Calibration occurs every 256ms
SDIV	5:0	Sawtooth Divider: Sawtooth divider value 0x00 sets the sawtooth divider to autocalibrate mode	000000: Sawtooth divider automatically calibrates the divider value 000001: Sawtooth divider set to 1 111111: Sawtooth divider set to 63

main_control (0x04)

BIT	7	6	5	4	3	2	1	0
Field	SEREN	CLINKEN	PRBSEN	SLEEP	RSVD[3:2]		REVCCEN	FWDCEN
Reset	1b	0b	0b	0b	01b		1b	1b
Access Type	Write, Read	Write, Read	Write, Read	Write, Read	Write, Read		Write, Read	Write, Read

BITFIELD	BITS	DESCRIPTION	DECODE
SEREN	7	Serialization Enable: Requires a valid PCLK for serialization	0: Disable serialization 1: Enable serialization
CLINKEN	6	Configuration Link Enable: Configuration link enabled only when the video link is not enabled (SEREN = 1)	0: Disable configuration link 1: Enable configuration link
PRBSEN	5	PRBS Test Enable: See the PRBS test section for more details	0: Disable PRBS test 1: Enable PRBS test
SLEEP	4	Sleep Mode Enable: Activates sleep mode (see the Shutdown/Sleep Modes section for more information)	0: Disable sleep mode 1: Enable sleep mode
RSVD	3:2	Reserved: Do not change from default value	01: Reserved
REVCCEN	1	Reverse Control-Channel Enable: Enable reverse control-channel receiver (data from deserializer)	0: Disable reverse control-channel receiver 1: Enable reverse control-channel receiver
FWDCEN	0	Forward Control Channel Enable: Enable forward control channel receiver (data to deserializer)	0: Disable forward control channel transmitter 1: Enable forward control channel transmitter

prbs_len (0x05)

BIT	7	6	5	4	3	2	1	0
Field	RSVD	RSVD	PRBS_LEN[1:0]		RSVD	RSVD	RSVD	RSVD
Reset	0b	0b	00b		0b	0b	0b	0b
Access Type	Write, Read	Write, Read	Write, Read		Write, Read	Write, Read	Write, Read	Write, Read

BITFIELD	BITS	DESCRIPTION	DECODE
RSVD	7	Reserved: Do not change from default value	0: Reserved
RSVD	6	Reserved: Do not change from default value	0: Reserved
PRBS_LEN	5:4	PRBS Length: PRBS test pattern length	00: Continuous bit pattern (infinite length) 01: 9.8Mbit length 10: 167.1Mbit length 11: 1341.5Mbit length
RSVD	3	Reserved: Do not change from default value	0: Reserved
RSVD	2	Reserved: Do not change from default value	0: Reserved
RSVD	1	Reserved: Do not change from default value	0: Reserved
RSVD	0	Reserved: Do not change from default value	0: Reserved

cmlvl_preemp (0x06)

BIT	7	6	5	4	3	2	1	0
Field	CMLLVL[3:0]				PREEMP[3:0]			
Reset	10X0b				0000b			
Access Type	Write, Read				Write, Read			

BITFIELD	BITS	DESCRIPTION	DECODE
CMLLVL	7:4	CML Level: Output CML signal level = (register value) x 50mV Default level depends on cable type (COTP)	0000: Do not use 0001: Do not use 0010: 100mV output 0011: 150mV output 0100: 200mV output 0101: 250mV output 0110: 300mV output 0111: 350mV output 1000: 400mV output (STP default) 1001: 450mV output 1010: 500mV output (coax default) 1011: Do not use 1100: Do not use 1101: Do not use 111X: Do not use
PREEMP	3:0	Preemphasis Level: Preemphasis setting	0000: Preemphasis off 0001: 1.2dB deemphasis 0010: 2.5dB deemphasis 0011: 4.1dB deemphasis 0100: 6.0dB deemphasis 0101: Do not use 011X: Do not use 1000: 1.1dB preemphasis 1001: 2.2dB preemphasis 1010: 3.3dB preemphasis 1011: 4.4dB preemphasis 1100: 6.0dB preemphasis 1101: 8.0dB preemphasis 1110: 10.5dB preemphasis 1111: 14.0dB preemphasis

config (0x07)

BIT	7	6	5	4	3	2	1	0
Field	DBL	RSVD	BWS	ES	RSVD	HVEN	RSVD	PXL_CRC
Reset	0b	0b	0b	0b	0b	0b	0b	0b
Access Type	Write, Read	Write, Read	Write, Read	Write, Read	Write, Read	Write, Read	Write, Read	Write, Read

BITFIELD	BITS	DESCRIPTION	DECODE
DBL	7	Double-Input Mode Enable: Set high to enable double-input mode	0: Single-input mode 1: Double-input mode
RSVD	6	Reserved: Do not change from default value	0: Reserved
BWS	5	Bus-Width Select	0: 24-bit and high-bandwidth mode 1: 32-bit mode
ES	4	Edge Select	0: Parallel data clocked in on rising edge 1: Parallel data clocked in on falling edge
RSVD	3	Reserved: Do not change from default value	0: Reserved
HVEN	2	HSYNC/VSNC Encoding Enable	0: Disable HS/VS encoding 1: Enable HS/VS encoding
RSVD	1	Reserved: Do not change from default value	0: Reserved
PXL_CRC	0	Pixel CRC Type: pixel error-detection type	0: Serial data uses 1-bit parity 1: Serial data uses 6-bit CRC

rsvd_8 (0x08)

BIT	7	6	5	4	3	2	1	0
Field	RSVD	RSVD	RSVD	RSVD	RSVD	RSVD	RSVD	RSVD
Reset	0b	0b	0b	0b	0b	0b	0b	0b
Access Type	Write, Read	Write, Read	Write, Read	Write, Read	Write, Read	Write, Read	Write, Read	Write, Read

BITFIELD	BITS	DESCRIPTION	DECODE
RSVD	7	Reserved: Do not change from default value	0: Reserved
RSVD	6	Reserved: Do not change from default value	0: Reserved
RSVD	5	Reserved: Do not change from default value	0: Reserved
RSVD	4	Reserved: Do not change from default value	0: Reserved
RSVD	3	Reserved: Do not change from default value	0: Reserved
RSVD	2	Reserved: Do not change from default value	0: Reserved
RSVD	1	Reserved: Do not change from default value	0: Reserved
RSVD	0	Reserved: Do not change from default value	0: Reserved

i2c_source (0x09, 0x0B)

BIT	7	6	5	4	3	2	1	0
Field	I2C_SRC[6:0]							RSVD
Reset	0000000b							0b
Access Type	Write, Read							Write, Read

BITFIELD	BITS	DESCRIPTION	DECODE
I2C_SRC	7:1	I²C Source: I ² C address translator source	0000000: Write/read device address is 0x00/0x01 0000001: Write/read device address is 0x02/0x03 1111111: Write/read device address is 0xFE/0xFF
RSVD	0	Reserved: Do not change from default value	0: Reserved

i2c_dest (0x0A, 0x0C)

BIT	7	6	5	4	3	2	1	0
Field	I2C_DST[6:0]							RSVD
Reset	0000000b							0b
Access Type	Write, Read							Write, Read

BITFIELD	BITS	DESCRIPTION	DECODE
I2C_DST	7:1	I²C Destination: I ² C address translator destination	0000000: Write/read device address is 0x00/0x01 0000001: Write/read device address is 0x02/0x03 1111111: Write/read device address is 0xFE/0xFF
RSVD	0	Reserved: Do not change from default value	0: Reserved

i2c_config (0x0D)

BIT	7	6	5	4	3	2	1	0
Field	I2C_LOC_ACK	I2C_SLV_SH[1:0]		I2C_MST_BT[2:0]			I2C_SLV_TO[1:0]	
Reset	1b	01b		101b			10b	
Access Type	Write, Read	Write, Read		Write, Read			Write, Read	

BITFIELD	BITS	DESCRIPTION	DECODE
I2C_LOC_ACK	7	I²C Local Acknowledge: I ² C-to-I ² C slave generates local acknowledge when forward channel is not available	0: Do not send local autoacknowledge when control channel is absent 1: Send local autoacknowledge when control channel is absent
I2C_SLV_SH	6:5	I²C Slave Setup/Hold Time: I ² C-to-I ² C slave setup and hold-time setting (setup, hold) (typ)	00: (352ns, 117ns) setup/hold time 01: (469ns, 234ns) setup/hold time 10: (938ns, 352ns) setup/hold time 11: (1406ns, 469ns) setup/hold time
I2C_MST_BT	4:2	I²C Master Bit Rate: I ² C-to-I ² C master bit-rate setting (min, typ, max)	000: (6.61, 8.47, 9.92) kbps 001: (22.1, 28.3, 33.2) kbps 010: (66.1, 84.7, 99.2) kbps 011: (82, 105, 123) kbps 100: (136, 173, 203) kbps 101: (265, 339, 397) kbps 110: (417, 533, 625) kbps 111: (654, 837, 980) kbps
I2C_SLV_TO	1:0	I²C Slave Timeout: I ² C-to-I ² C slave remote-side timeout setting (typ).	00: 64μs slave timeout 01: 256μs slave timeout 10: 1024μs slave timeout 11: Slave timeout disabled

gpio_en (0x0E)

BIT	7	6	5	4	3	2	1	0
Field	RSVD	RSVD	RSVD	RSVD	RSVD	GPIO_EN_2	GPIO_EN_1	RSVD
Reset	0b	0b	0b	0b	0b	0b	0b	0b
Access Type	Write, Read	Write, Read	Write, Read	Write, Read	Write, Read	Write, Read	Write, Read	Write, Read

BITFIELD	BITS	DESCRIPTION	DECODE
RSVD	7	Reserved: Do not change from default value	0: Reserved
RSVD	6	Reserved: Do not change from default value	0: Reserved
RSVD	5	Reserved: Do not change from default value	0: Reserved
RSVD	4	Reserved: Do not change from default value	0: Reserved
RSVD	3	Reserved: Do not change from default value	0: Reserved
GPIO_EN_2	2	GPIO Enable: Disabled by default	0: Pin functions as a parallel input 1: Pin functions as a GPIO
GPIO_EN_1	1	GPIO Enable: Disabled by default	0: Pin functions as parallel input 1: Pin functions as GPIO
RSVD	0	Reserved: Do not change from default value	0: Reserved

gpio_out (0x0F)

BIT	7	6	5	4	3	2	1	0
Field	EN_SET_GPO	RSVD	RSVD	RSVD	RSVD	GPIO_OUT_2	GPIO_OUT_1	SET_GPO
Reset	0b	0b	1b	1b	1b	1b	1b	0b
Access Type	Write, Read	Write, Read	Write, Read	Write, Read	Write, Read	Write, Read	Write, Read	Write, Read

BITFIELD	BITS	DESCRIPTION	DECODE
EN_SET_GPO	7	Enable Set GPO: Set to 1 to enable setting of GPO from SET_GPO	0: Disable setting of GPO through SET_GPO 1: Enable setting of GPO through SET_GPO
RSVD	6	Reserved: Do not change from default value	0: Reserved
RSVD	5	Reserved: Do not change from default value	1: Reserved
RSVD	4	Reserved: Do not change from default value	1: Reserved
RSVD	3	Reserved: Do not change from default value	1: Reserved
GPIO_OUT_2	2	GPIO Output Level: Pull down GPIO when 0	0: Set GPIO output level low 1: Set GPIO output level high
GPIO_OUT_1	1	GPIO Output Level: Pull down GPIO when 0	0: Set GPIO output level low 1: Set GPIO output level high
SET_GPO	0	Set GPO Level: Set GPO output high or low (when EN_SET_GPO = 1)	0: Set GPO output low 1: Set GPO output high

gpio_in (0x10)

BIT	7	6	5	4	3	2	1	0
Field	RSVD	RSVD	RSVD	RSVD	RSVD	GPIO_IN_2	GPIO_IN_1	GPO_L
Reset	0b	0b	0b	0b	0b	Xb	Xb	0b
Access Type	Read Only	Read Only	Read Only	Read Only	Read Only	Read Only	Read Only	Read Only

BITFIELD	BITS	DESCRIPTION	DECODE
RSVD	7	Reserved	0: Reserved
RSVD	6	Reserved	0: Reserved
RSVD	5	Reserved	X: Reserved
RSVD	4	Reserved	X: Reserved
RSVD	3	Reserved	X: Reserved
GPIO_IN_2	2	GPIO Input Level: Input pin level of GPIO	0: GPIO input is low 1: GPIO input is high
GPIO_IN_1	1	GPIO Input Level: Input pin level of GPIO	0: GPIO input is low 1: GPIO input is high
GPO_L	0	GPO Output Level	0: GPI output level is low 1: GPO output level is high

errg (0x11)

BIT	7	6	5	4	3	2	1	0
Field	ERRG_RATE[1:0]		ERRG_TYPE[1:0]		ERRG_CNT[1:0]		ERRG_PER	ERRG_EN
Reset	0b		0b		0b		0b	0b
Access Type	Write, Read		Write, Read		Write, Read		Write, Read	Write, Read

BITFIELD	BITS	DESCRIPTION	DECODE
ERRG_RATE	7:6	Error-Generation Rate: Error-generation rate, on average	00: Generate errors every 2560 bits 01: Generate errors every 40,960 bits 10: Generate errors every 655,360 bits 11: Generate errors every 10,485,760 bits
ERRG_TYPE	5:4	Error-Generation Type: Type of generated errors	00: Single-bit errors 01: 2 8b/10b symbols 10: 3 8b/10b symbols 11: 4 8b/10b symbols
ERRG_CNT	3:2	Error-Generation Count: Number of generated errors	00: Generate errors continuously 01: Generate 16 errors 10: Generate 128 errors 11: Generate 1024 errors
ERRG_PER	1	Periodic Error Generation Enable	0: Generator creates errors randomly (based on error rate) 1: Generator creates errors periodically (based on error rate)
ERRG_EN	0	Error Generator Enable	0: Disable error generator 1: Enable error generator

rsvd_12 (0x12)

BIT	7	6	5	4	3	2	1	0
Field	RSVD	RSVD	RSVD	RSVD[4:0]				
Reset	0b	1b	0b	00000b				
Access Type	Write, Read	Write, Read	Write, Read	Write, Read				

BITFIELD	BITS	DESCRIPTION	DECODE
RSVD	7	Reserved: Do not change from default value	0: Reserved
RSVD	6	Reserved: Do not change from default value	1: Reserved
RSVD	5	Reserved: Do not change from default value	0: Reserved
RSVD	4:0	Reserved: Do not change from default value	00000: Reserved

pd (0x13)

BIT	7	6	5	4	3	2	1	0
Field	SOFT_PD	RSVD	RSVD	RSVD	RSVD	RSVD	RSVD[1:0]	
Reset	0b	0b	0b	0b	0b	0b	10b	
Access Type	Write 1 to Set, Read	Write, Read	Write, Read	Write, Read	Write, Read	Write, Read	Write, Read	

BITFIELD	BITS	DESCRIPTION	DECODE
SOFT_PD	7	Soft Power Down: Set this bit to 1 to reset the device; this bit is cleared after the device resets	0: Normal operation 1: Reset the device (bit clears itself)
RSVD	6	Reserved: Do not change from default value	0: Reserved
RSVD	5	Reserved: Do not change from default value	0: Reserved
RSVD	4	Reserved: Do not change from default value	0: Reserved
RSVD	3	Reserved: Do not change from default value	0: Reserved
RSVD	2	Reserved: Do not change from default value	0: Reserved
RSVD	1:0	Reserved: Do not change from default value	10: Reserved

rsvd_14 (0x14)

BIT	7	6	5	4	3	2	1	0
Field	RSVD[1:0]		RSVD	RSVD	RSVD	RSVD	RSVD	RSVD
Reset	XXb		Xb	Xb	Xb	Xb	Xb	Xb
Access Type	Read Only		Read Only	Read Only	Read Clears All	Read Only	Read Only	Read Only

BITFIELD	BITS	DESCRIPTION	DECODE
RSVD	7:6	Reserved	XX: Reserved
RSVD	5	Reserved	X: Reserved
RSVD	4	Reserved	X: Reserved
RSVD	3	Reserved	X: Reserved
RSVD	2	Reserved	X: Reserved
RSVD	1	Reserved	X: Reserved
RSVD	0	Reserved	X: Reserved

input_status (0x15)

BIT	7	6	5	4	3	2	1	0
Field	RSVD	RSVD	RSVD	RSVD	RSVD	RSVD	OUTPUTEN	PCLKDET
Reset	Xb	Xb	Xb	0b	0b	0b	Xb	Xb
Access Type	Read Only	Read Only	Write, Read	Read Only	Read Only	Read Only	Read Only	Read Only

BITFIELD	BITS	DESCRIPTION	DECODE
RSVD	7	Reserved	X: Reserved
RSVD	6	Reserved	X: Reserved
RSVD	5	Reserved	X: Reserved
RSVD	4	Reserved	0: Reserved
RSVD	3	Reserved	0: Reserved
RSVD	2	Reserved	0: Reserved
OUTPUTEN	1	Output Enabled	0: Output disabled 1: Output enabled
PCLKDET	0	PCLK Detected: Valid PCLK detected	0: No valid PCLK detected 1: Valid PCLK detected

rsvd_16 (0x16)

BIT	7	6	5	4	3	2	1	0
Field	RSVD	RSVD	RSVD[5:0]					
Reset	0b	Xb	XXXXXXb					
Access Type	Read Only	Read Clears All	Read Only					

BITFIELD	BITS	DESCRIPTION	DECODE
RSVD	7	Reserved	0: Reserved
MAX_RT_ERR	6	Reserved	X: Reserved
RSVD	5:0	Reserved	XXXXXX: Reserved

rsvd_17 (0x17)

BIT	7	6	5	4	3	2	1	0
Field	RSVD[7:0]							
Reset	XXXXXXXXb							
Access Type	Read Only							

BITFIELD	BITS	DESCRIPTION	DECODE
RSVD	7:0	Reserved	XXXXXXXX: Reserved

rsvd (0x18 to 0x1B)

BIT	7	6	5	4	3	2	1	0
Field	RSVD							
Reset	XXXXXXXXb							
Access Type	Read Only							

BITFIELD	BITS	DESCRIPTION	DECODE
RSVD	7:0	Reserved	XXXXXXXX: Reserved

rsvd (0x1C)

BIT	7	6	5	4	3	2	1	0
Field	RSVD							
Reset	XXXXXXXXb							
Access Type	Read Only							

BITFIELD	BITS	DESCRIPTION	DECODE
RSVD	7:0	Reserved	XXXXXXXX: Reserved

rsvd_1D (0x1D)

BIT	7	6	5	4	3	2	1	0
Field	RSVD[7:0]							
Reset	XXXXXXXXb							
Access Type	Read Only							

BITFIELD	BITS	DESCRIPTION	DECODE
RSVD	7:0	Reserved	XXXXXXXX: Reserved

id (0x1E)

BIT	7	6	5	4	3	2	1	0
Field	ID[7:0]							
Reset	XXXXXXXXb							
Access Type	Read Only							

BITFIELD	BITS	DESCRIPTION	DECODE
ID	7:0	Device ID: 8-bit value depends on the GMSL device attached	01000111 Device is a MAX96709

revision (0x1F)

BIT	7	6	5	4	3	2	1	0
Field	RSVD	RSVD	RSVD	HDCPCAP	REVISION[3:0]			
Reset	0b	0b	0b	Xb	XXXXb			
Access Type	Read Only	Read Only	Read Only	Read Only	Read Only			

BITFIELD	BITS	DESCRIPTION	DECODE
RSVD	7	Reserved	0: Reserved
RSVD	6	Reserved	0: Reserved
RSVD	5	Reserved	0: Reserved
HDCPCAP	4	HDCP Capability: 1 = HDCP capable	0: Device does not have HDCP 1: Device is HDCP capable
REVISION	3:0	Device Revision	0000: Value is 0 0001: Value is 1 1111: Value is 15

crossbar (0x20 to 0x3E)

BIT	7	6	5	4	3	2	1	0
Field	RSVD	FORCE_ MUX	INVERT_ MUX	CROSSBAR[4:0]				
Reset	0b	0b	0b	XXXXXb				
Access Type	Write, Read	Write, Read	Write, Read	Write, Read				

BITFIELD	BITS	DESCRIPTION	DECODE
RSVD	7	Reserved: Do not change from default value	0: Reserved
FORCE_ MUX	6	Force Mux Output	0: Input mapped to mux output 1: Force mux output low
INVERT_ MUX	5	Invert Mux Output	0: Do not invert mux output 1: Invert mux output
CROSS- BAR	4:0	Crossbar Setting Select 1 of 32 input signals. Default values connect Mux N with input N for flow-through routing (i.e., DIN_ mapped to DOUT_).	00000: Mux outputs data from input 0 00001: Mux outputs data from input 1 11111: Mux outputs data from input 31

crossbar_hs (0x3F)

BIT	7	6	5	4	3	2	1	0
Field	RSVD	FORCE_ MUX_HS	INVERT_ MUX_HS	CROSSBARHS[4:0]				
Reset	0b	0b	0b	01100b				
Access Type	Write, Read	Write, Read	Write, Read	Write, Read				

BITFIELD	BITS	DESCRIPTION	DECODE
RSVD	7	Reserved: Do not change from default value	0: Reserved
FORCE_ MUX_HS	6	Force Mux Output	0: Input mapped to mux output 1: Force mux output low
INVERT_ MUX_HS	5	Invert Mux Output	0: Do not invert mux output 1: Invert mux output
CROSS- BARHS	4:0	Crossbar Setting HS: Select 1 of 16 input pins for HS. Default values connect HS with the corresponding named input pin. Unconnected inputs (DIN14, DIN15) are internally connected low.	00000: Mux sync signal from DIN0 00001: Mux sync signal from DIN1 01111: Mux sync signal from DIN15 1XXXX: Do Not Use

crossbar_vs (0x40)

BIT	7	6	5	4	3	2	1	0
Field	RSVD	FORCE_ MUX_VS	INVERT_ MUX_VS	CROSSBARVS[4:0]				
Reset	0b	0b	0b	01101b				
Access Type	Write, Read	Write, Read	Write, Read	Write, Read				

BITFIELD	BITS	DESCRIPTION	DECODE
RSVD	7	Reserved: Do not change from default value	0: Reserved
FORCE_ MUX_VS	6	Force Mux Output	0: Input mapped to mux output 1: Force mux output low
INVERT_ MUX_VS	5	Invert Mux Output	0: Do not invert mux output 1: Invert mux output
CROSS- BARVS	4:0	Crossbar Setting VS: Select 1 of 16 input pins for VS. Default values connect VS with the corresponding named input pin. Unconnected inputs (DIN14, DIN15) are internally connected low.	00000: Mux sync signal from DIN0 00001: Mux sync signal from DIN1 01111: Mux sync signal from DIN15 1XXXX: Do Not Use

crossbar_de (0x41)

BIT	7	6	5	4	3	2	1	0
Field	RSVD	FORCE_MUX_DE	INVERT_MUX_DE	CROSSBARDE[4:0]				
Reset	0b	0b	0b	01011b				
Access Type	Write, Read	Write, Read	Write, Read	Write, Read				

BITFIELD	BITS	DESCRIPTION	DECODE
RSVD	7	Reserved: Do not change from default value	0: Reserved
FORCE_MUX_DE	6	Force Mux Output	0: Input mapped to mux output. 1: Force mux output low.
INVERT_MUX_DE	5	Invert Mux Output	0: Do not invert mux output. 1: Invert mux output.
CROSSBARDE	4:0	Crossbar Setting DE: Select 1 of 16 input pins for DE. Default values connect DE with DIN11. Unconnected inputs (DIN14, DIN15) are internally connected low.	00000: Mux sync signal from DIN0 00001: Mux sync signal from DIN1 01111: Mux sync signal from DIN15 1XXXX: Do Not Use

link_config (0x42)

BIT	7	6	5	4	3	2	1	0
Field	RSVD[1:0]		RSVD	RSVD	RSVD	RSVD	RSVD	GPO_EN
Reset	01b		0b	1b	1b	0b	1b	1b
Access Type	Write, Read		Write, Read	Write, Read	Write, Read	Write, Read	Write, Read	Write, Read

BITFIELD	BITS	DESCRIPTION	DECODE
RSVD	7:6	Reserved: Do not change from default value	01: Reserved
RSVD	5	Reserved: Do not change from default value	0: Reserved
RSVD	4	Reserved: Do not change from default value	1: Reserved
RSVD	3	Reserved: Do not change from default value	1: Reserved
RSVD	2	Reserved: Do not change from default value	0: Reserved
RSVD	1	Reserved: Do not change from default value	1: Reserved
GPO_EN	0	GPO Enable: Enable GPO pin	0: Disable GPO pin 1: Enable GPO pin

rsvd_43 (0x43)

BIT	7	6	5	4	3	2	1	0
Field	RSVD	RSVD	RSVD	RSVD	RSVD	RSVD	RSVD[1:0]	
Reset	0b	0b	0b	0b	0b	1b	01b	
Access Type	Write, Read	Write, Read	Write, Read	Write, Read	Write, Read	Write, Read	Write, Read	

BITFIELD	BITS	DESCRIPTION	DECODE
RSVD	7	Reserved: Do not change from default value	0: Reserved
RSVD	6	Reserved: Do not change from default value	0: Reserved
RSVD	5	Reserved: Do not change from default value	0: Reserved
RSVD	4	Reserved: Do not change from default value	0: Reserved
RSVD	3	Reserved: Do not change from default value	0: Reserved
RSVD	2	Reserved: Do not change from default value	1: Reserved
RSVD	1:0	Reserved: Do not change from default value	01: Reserved

rsvd (0x44 to 0x46)

BIT	7	6	5	4	3	2	1	0
Field	RSVD[7:0]							
Reset	00000000b							
Access Type	Write, Read							

BITFIELD	BITS	DESCRIPTION	DECODE
RSVD	7:0	Reserved: Do not change from default value	00000000:Reserved

rsvd (0x47 to 0x49)

BIT	7	6	5	4	3	2	1	0
Field	RSVD[7:0]							
Reset	00000000b							
Access Type	Write, Read							

BITFIELD	BITS	DESCRIPTION	DECODE
RSVD	7:0	Reserved: Do not change from default value	00000000:Reserved

rsvd (0x4A to 0x4C)

BIT	7	6	5	4	3	2	1	0
Field	RSVD[7:0]							
Reset	00000000b							
Access Type	Write, Read							

BITFIELD	BITS	DESCRIPTION	DECODE
RSVD	7:0	Reserved: Do not change from default value	00000000:Reserved

cxtp (0x4D)

BIT	7	6	5	4	3	2	1	0
Field	RSVD	CXTP	RSVD	RSVD	RSVD	RSVD	RSVD	RSVD
Reset	Xb	0b	0b	0b	0b	0b	0b	0b
Access Type	Write, Read	Write, Read	Write, Read	Write, Read	Write, Read	Write, Read	Write, Read	Write, Read

BITFIELD	BITS	DESCRIPTION	DECODE
RSVD	7	Reserved: Do not change from default value	X: Reserved
CXTP	6	Coax/Twisted-Pair Select: Default to STP mode	0: Use differential output (STP mode) 1: Use dual single ended outputs (coax)
RSVD	5	Reserved: Do not change from default value	0: Reserved
RSVD	4	Reserved: Do not change from default value	0: Reserved
RSVD	3	Reserved: Do not change from default value	0: Reserved
RSVD	2	Reserved: Do not change from default value	0: Reserved
RSVD	1	Reserved: Do not change from default value	0: Reserved
RSVD	0	Reserved: Do not change from default value	0: Reserved

rsvd (0x4E to 0x50)

BIT	7	6	5	4	3	2	1	0
Field	RSVD[7:0]							
Reset	00000000b							
Access Type	Write, Read							

BITFIELD	BITS	DESCRIPTION	DECODE
RSVD	7:0	Reserved: Do not change from default value	00000000:Reserved

rsvd (0x51 to 0x53, 0x5D to 0x5F)

BIT	7	6	5	4	3	2	1	0
Field	RSVD[7:0]							
Reset	00000000b							
Access Type	Write, Read							

BITFIELD	BITS	DESCRIPTION	DECODE
RSVD	7:0	Reserved: Do not change from default value	00000000:Reserved

rsvd (0x54, 0x55)

BIT	7	6	5	4	3	2	1	0
Field	RSVD[7:0]							
Reset	0000000b							
Access Type	Write, Read							

BITFIELD	BITS	DESCRIPTION	DECODE
RSVD	7:0	Reserved: Do not change from default value	00000000:Reserved

rsvd (0x56, 0x57)

BIT	7	6	5	4	3	2	1	0
Field	RSVD[7:0]							
Reset	0000000b							
Access Type	Write, Read							

BITFIELD	BITS	DESCRIPTION	DECODE
RSVD	7:0	Reserved: Do not change from default value	00000000:Reserved

rsvd (0x58, 0x59)

BIT	7	6	5	4	3	2	1	0
Field	RSVD[7:0]							
Reset	0000000b							
Access Type	Write, Read							

BITFIELD	BITS	DESCRIPTION	DECODE
RSVD	7:0	Reserved: Do not change from default value	00000000:Reserved

rsvd (0x5A to 0x5C)

BIT	7	6	5	4	3	2	1	0
Field	RSVD[7:0]							
Reset	0000000b							
Access Type	Write, Read							

BITFIELD	BITS	DESCRIPTION	DECODE
RSVD	7:0	Reserved: Do not change from default value	00000000:Reserved

rsvd (0x60, 0x61)

BIT	7	6	5	4	3	2	1	0
Field	RSVD[7:0]							
Reset	0000000b							
Access Type	Write, Read							

BITFIELD	BITS	DESCRIPTION	DECODE
RSVD	7:0	Reserved: Do not change from default value	00000000:Reserved

rsvd (0x62, 0x63)

BIT	7	6	5	4	3	2	1	0
Field	RSVD[7:0]							
Reset	00000000b							
Access Type	Write, Read							

BITFIELD	BITS	DESCRIPTION	DECODE
RSVD	7:0	Reserved: Do not change from default value	00000000:Reserved

rsvd (0x64, 0x65)

BIT	7	6	5	4	3	2	1	0
Field	RSVD[7:0]							
Reset	00000000b							
Access Type	Write, Read							

BITFIELD	BITS	DESCRIPTION	DECODE
RSVD	7:0	Reserved: Do not change from default value	00000000:Reserved

prbs_type (0x66)

BIT	7	6	5	4	3	2	1	0
Field	RSVD[1:0]		PRBS_ TYPE	REV_FAST	RSVD	DIS_ RWAKE	RSVD	CXSEL
Reset	01b		1b	0b	0b	0b	0b	1b
Access Type	Write, Read		Write, Read	Write, Read	Write, Read	Write, Read	Write, Read	Write, Read

BITFIELD	BITS	DESCRIPTION	DECODE
RSVD	7:6	Reserved: Do not change from default value	01: Reserved
PRBS_ TYPE	5	PRBS Type: PRBS type select	0: Select legacy PRBS mode 1: Select MAX9271–MAX9273 PRBS mode
REV_ FAST	4	Reverse Channel Fast-Mode Enable	0: Disable reverse channel fast mode 1: Enable reverse channel fast mode
RSVD	3	Reserved: Do not change from default value	0: Reserved
DIS_ RWAKE	2	Disable Remote Wake-Up: Disable wake-up receiver	0: Do not disable remote wake-up receiver 1: Disable remote wake-up receiver
RSVD	1	Reserved: Do not change from default value	0: Reserved
CXSEL	0	Coax Select	0: Coax cable connected to inverting output 1: Coax cable connected to noninverting output

auto_clink (0x67)

BIT	7	6	5	4	3	2	1	0
Field	RSVD[1:0]		AUTO_CLINK	RSVD	RSVD	RSVD[2:0]		
Reset	11b		0b	0b	0b	111b		
Access Type	Write, Read		Write, Read	Write, Read	Write, Read	Write, Read		

BITFIELD	BITS	DESCRIPTION	DECODE
RSVD	7:6	Reserved: Do not change from default value	11: Reserved
AUTO_CLINK	5	Auto Configuration Link: Automatic control of configuration link	0: Enable configuration link only when CLINKEN = 1 and SEREN = 0 1: Automatically enable configuration link when SEREN = 1 and PCLKDET = 0
RSVD	4	Reserved: Do not change from default value	0: Reserved
RSVD	3	Reserved: Do not change from default value	0: Reserved
RSVD	2:0	Reserved: Do not change from default value	111: Reserved

rsvd_68 (0x68)

BIT	7	6	5	4	3	2	1	0
Field	RSVD	RSVD[2:0]			RSVD[1:0]		RSVD[1:0]	
Reset	0b	001b			10b		01b	
Access Type	Write, Read	Write, Read			Write, Read		Write, Read	

BITFIELD	BITS	DESCRIPTION	DECODE
RSVD	7	Reserved: Do not change from default value	0: Reserved
RSVD	6:4	Reserved: Do not change from default value	001: Reserved
RSVD	3:2	Reserved: Do not change from default value	10: Reserved
RSVD	1:0	Reserved: Do not change from default value	00: Reserved

rsvd_69 (0x69)

BIT	7	6	5	4	3	2	1	0
Field	RSVD	RSVD	RSVD	RSVD[4:0]				
Reset	0b	0b	0b	01101				
Access Type	Write, Read	Write, Read	Write, Read	Write, Read				

BITFIELD	BITS	DESCRIPTION	DECODE
RSVD	7	Reserved: Do not change from default value	0: Reserved
RSVD	6	Reserved: Do not change from default value	0: Reserved
RSVD	5	Reserved: Do not change from default value	0: Reserved
RSVD	4:0	Reserved: Do not change from default value	01101: Reserved

rsvd_96 (0x96)

BIT	7	6	5	4	3	2	1	0
Field	RSVD	RSVD	RSVD	RSVD	RSVD	RSVD	RSVD[1:0]	
Reset	0b	0b	0b	0b	0b	1b	10b	
Access Type	Write, Read	Write, Read	Write, Read	Write, Read	Write, Read	Write, Read	Write, Read	

BITFIELD	BITS	DESCRIPTION	DECODE
RSVD	7	Reserved: Do not change from default value	0: Reserved
RSVD	6	Reserved: Do not change from default value	0: Reserved
RSVD	5	Reserved: Do not change from default value	0: Reserved
RSVD	4	Reserved: Do not change from default value	0: Reserved
RSVD	3	Reserved: Do not change from default value	0: Reserved
RSVD	2	Reserved: Do not change from default value	1b: Reserved
RSVD	1:0	Reserved: Do not change from default value	10: Reserved

rsvd_97 (0x97)

BIT	7	6	5	4	3	2	1	0
Field	RSVD	RSVD	RSVD	RSVD	RSVD	RSVD[2:0]		
Reset	0b	0b	0b	1b	1b	111b		
Access Type	Write, Read	Write, Read	Write, Read	Write, Read	Write, Read	Write, Read		

BITFIELD	BITS	DESCRIPTION	DECODE
RSVD	7	Reserved: Do not change from default value	0: Reserved
RSVD	6	Reserved: Do not change from default value	0: Reserved
RSVD	5	Reserved: Do not change from default value	0: Reserved
RSVD	4	Reserved: Do not change from default value	1: Reserved
RSVD	3	Reserved: Do not change from default value	1: Reserved
RSVD	2:0	Reserved: Do not change from default value	111: Reserved

rsvd_98 (0x98)

BIT	7	6	5	4	3	2	1	0
Field	RSVD[1:0]		RSVD[2:0]			RSVD[2:0]		
Reset	01b		001b			010b		
Access Type	Write, Read		Write, Read			Write, Read		

BITFIELD	BITS	DESCRIPTION	DECODE
RSVD	7:6	Reserved: Do not change from default value	01: Reserved
RSVD	5:3	Reserved: Do not change from default value	001: Reserved
RSVD	2:0	Reserved: Do not change from default value	010: Reserved

rsvd_99 (0x99)

BIT	7	6	5	4	3	2	1	0
Field	RSVD	RSVD	RSVD	RSVD	RSVD	RSVD	RSVD[1:0]	
Reset	0b	0b	0b	0b	1b	1b	01b	
Access Type	Write, Read	Write, Read	Write, Read	Write, Read	Write, Read	Write, Read	Write, Read	

BITFIELD	BITS	DESCRIPTION	DECODE
RSVD	7	Reserved: Do not change from default value	0: Reserved
RSVD	6	Reserved: Do not change from default value	0: Reserved
RSVD	5	Reserved: Do not change from default value	0: Reserved
RSVD	4	Reserved: Do not change from default value	0: Reserved
RSVD	3	Reserved: Do not change from default value	1: Reserved
RSVD	2	Reserved: Do not change from default value	1: Reserved
RSVD	1:0	Reserved: Do not change from default value	01: Reserved

rsvd_9A (0x9A)

BIT	7	6	5	4	3	2	1	0
Field	RSVD[1:0]		RSVD[1:0]		RSVD	RSVD[1:0]		RSVD
Reset	00b		01b		0b	00b		0b
Access Type	Write, Read		Write, Read		Write, Read	Write, Read		Write, Read

BITFIELD	BITS	DESCRIPTION	DECODE
RSVD	7:6	Reserved: Do not change from default value	00: Reserved
RSVD	5:4	Reserved: Do not change from default value	01: Reserved
RSVD	3	Reserved: Do not change from default value	0: Reserved
RSVD	2:1	Reserved: Do not change from default value	00: Reserved
RSVD	0	Reserved: Do not change from default value	0: Reserved

rsvd_C8 (0xC8)

BIT	7	6	5	4	3	2	1	0
Field	RSVD	RSVD	RSVD	RSVD	RSVD[1:0]		RSVD[1:0]	
Reset	0b	Xb	Xb	Xb	10b		10b	
Access Type	Read Only	Read Only	Read Only	Read Only	Read Only		Read Only	

BITFIELD	BITS	DESCRIPTION	DECODE
RSVD	7	Reserved	0: Reserved
RSVD	6	Reserved	X: Reserved
RSVD	5	Reserved	X: Reserved
RSVD	4	Reserved	X: Reserved
RSVD	3:2	Reserved	10: Reserved
RSVD	1:0	Reserved	10: Reserved

rsvd_c9 (0xC9)

BIT	7	6	5	4	3	2	1	0
Field	RSVD[7:0]							
Reset	XXXXXXXXb							
Access Type	Read Only							

BITFIELD	BITS	DESCRIPTION	DECODE
RSVD	7:0	Reserved	XXXXXXXX: Reserved

rsvd_fc (0xFC)

BIT	7	6	5	4	3	2	1	0
Field	RSVD	RSVD	RSVD	RSVD	RSVD	RSVD	RSVD	RSVD
Reset	0b	0b	0b	0b	0b	0b	0b	0b
Access Type	Write, Read	Write, Read	Write, Read	Write, Read	Write, Read	Write, Read	Write, Read	Write, Read

BITFIELD	BITS	DESCRIPTION	DECODE
RSVD	7	Reserved: Do not change from default value	0: Reserved
RSVD	6	Reserved: Do not change from default value	0: Reserved
RSVD	5	Reserved: Do not change from default value	0: Reserved
RSVD	4	Reserved: Do not change from default value	0: Reserved
RSVD	3	Reserved: Do not change from default value	0: Reserved
RSVD	2	Reserved: Do not change from default value	0: Reserved
RSVD	1	Reserved: Do not change from default value	0: Reserved
RSVD	0	Reserved: Do not change from default value	0: Reserved

rsvd_fd (0xFD)

BIT	7	6	5	4	3	2	1	0
Field	RSVD[7:0]							
Reset	00000000b							
Access Type	Write, Read							

BITFIELD	BITS	DESCRIPTION	DECODE
RSVD	7:0	Reserved: Do not change from default value	00000000: Reserved

rsvd_fe (0xFE)

BIT	7	6	5	4	3	2	1	0
Field	RSVD[3:0]				RSVD[3:0]			
Reset	0000b				0000b			
Access Type	Write, Read				Write, Read			

BITFIELD	BITS	DESCRIPTION	DECODE
RSVD	7:4	Reserved: Do not change from default value	0000: Reserved
RSVD	3:0	Reserved: Do not change from default value	0000: Reserved

rsvd_ff (0xFF)

BIT	7	6	5	4	3	2	1	0
Field	RSVD	RSVD	RSVD	RSVD	RSVD[3:0]			
Reset	0b	0b	0b	0b	XXXXb			
Access Type	Write, Read	Write, Read	Write, Read	Write, Read	Read Only			

BITFIELD	BITS	DESCRIPTION	DECODE
RSVD	7	Reserved: Do not change from default value	0: Reserved
RSVD	6	Reserved: Do not change from default value	0: Reserved
RSVD	5	Reserved: Do not change from default value	0: Reserved
RSVD	4	Reserved: Do not change from default value	0: Reserved
RSVD	3:0	Reserved	XXXX: Reserved

Applications Information

Parallel Interface

The CMOS parallel interface-data width is programmable and depends on the application. Using a larger width (BWS = 1) results in a lower-pixel clock rate, while a smaller width (BWS = 0) allows a higher-pixel clock rate.

Bus Data Width

The bus data width depends on the selected modes. The available bus width is less when using error detection or

when in double mode (DBL = 1). [Table 3](#) shows the available bit widths and default mapping for various modes.

Bus Data Rates

The bus data rate depends on the settings for BWS and DBL. [Table 4](#) lists the available PCLK rates available for different bus-width settings. For lower PCLK rates, set DBL = 0 (if DBL = 1 in both the serializer and deserializer).

Table 3. Input Data-Width Selection

REGISTER BIT SETTINGS				INPUT MAPPING
DBL	BWS	PXL_CRC	HVEN	
1	1	1	1	DIN11:0, HS, VS
1	1	1	0	DIN11:0
1	1	0	1	DIN11:0*, HS, VS
1	1	0	0	DIN13:0*
1	0	1	1	DIN7:0, HS, VS
1	0	1	0	DIN7:0
1	0	0	1	DIN10:0, HS, VS
1	0	0	0	DIN10:0
0	1	1	1	DIN11:0*, HS, VS
0	1	1	0	DIN13:0*
0	1	0	1	DIN11:0*, HS, VS
0	1	0	0	DIN13:0*
0	0	1	1	DIN11:0*, HS, VS
0	0	1	0	DIN13:0*
0	0	0	1	DIN11:0*, HS, VS
0	0	0	0	DIN13:0*

*The input bit width is limited by the number of available inputs.

Table 4. Data-Rate Selection

DBL	BWS	PCLK RANGE (MHz)
1	1	25 to 87
1	0	33.3 to 116
0	1	12.5 to 43.5
0	0	16.7 to 58

Crossbar Switch

By default, the crossbar switch connects the serializer input pins DIN_ and HS/VS (when HV encoding is used) to the corresponding deserializer output pins DOUT_ and HS/VS. Reprogram the crossbar switch when changing the input or output pin assignments, or when connecting to devices that do not have a DBL = 1 mode.

Crossbar-Switch Programming

Each crossbar-switch output can select any of the 14 DIN_ inputs for either high or low words (when DBL = 1) for a total of 32 possible inputs. Multiple outputs can share the same input. HS, VS, and DE remain the same for both word halves, and should be programmed to use the low-word input of the corresponding pin. To invert an input data bit, set the respective INVERT_MUX_ = 1. To force an output low, (and ignore the input) set the FORCE_MUX_ bit = 1. To force an output high set both INVERT_MUX_ and FORCE_MUX_ = 1.

Recommended Crossbar-Switch Program Procedure

The procedure to program the crossbar switch depends on the DBL settings on the SerDes. Devices without double mode can be assumed to have DBL = 0.

• **Both Devices' DBL Set to the Same Value**

1. For the crossbar-output equivalent of DIN0 (XBO0, XBO16) select which pin to map (e.g., DIN4 → XBI4, XBI20).
2. Set the low- and high-input crossbar bits (CROSSBAR0, CROSSBAR 16) to the desired selected mapped input (e.g., CROSSBAR0 = 00100, CROSSBAR16 = 10100).
3. Repeat for the other crossbar outputs, making sure the set of high and low crossbar outputs are assigned to the same crossbar input set. In general, XBO[i] and XBO[i+16] should be assigned to XBI[j] and XBI[j+16].
4. For XBOHS, XBOVS, and XBODE, set crossbar to use the low-input pins (CROSSBAR_ = 00000 to 01111). Note that HS, VS, and DE use both the low and high input.

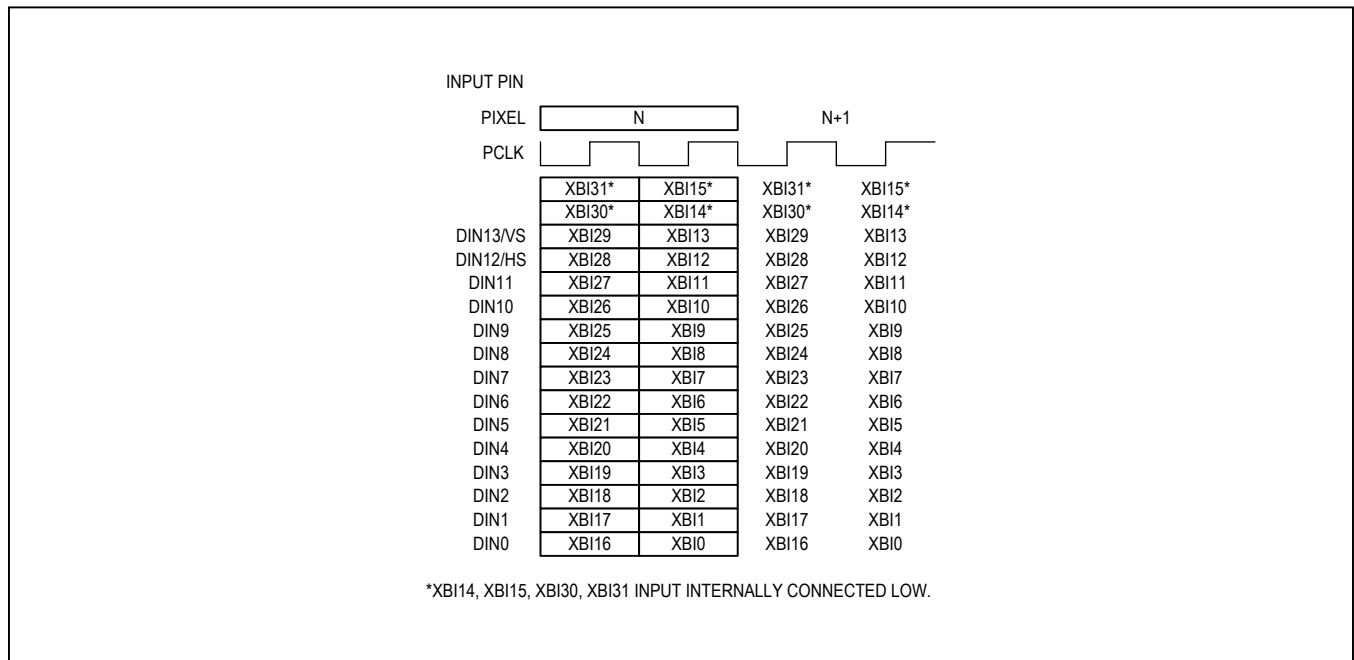

Figure 18. Crossbar-Switch Default Mapping

I²C Interface

The control channel forwards I²C commands from the microcontroller side to the other side of the GMSL link. The remote device acts as an I²C master to the other peripherals connected to the remote-side device. I²C-to-I²C mode uses clock stretching to hold the microcontroller until the data and an acknowledge or not acknowledge have been sent across the link.

I²C Bit Rate

The I²C interface accepts bit rates from 9.6kbps to 1Mbps. The local I²C rate is set by the microcontroller. The remote I²C rate is set by the remote device. By default, the control channel is set up for a 400kbps I²C bit rate. Program the I²C_MSTBT and SLV_SH bits (register 0x0D) to match the desired microcontroller I²C rate.

Software Programming of Device Addresses

The SerDes have programmable device addresses. This allows multiple GMSL devices, along with I²C peripherals, to coexist on the same control channel. The serializer device address is in register 0x00 of each device, while the deserializer device address is in register 0x01 of each device. To change a device address, first write to the device whose address changes (register 0x00 of the serializer for serializer device address change, or register 0x01 of the deserializer for deserializer device address change). Then, write the same address into the corresponding register on the other device (register 0x00 of the deserializer for serializer device address change, or register 0x01 of the serializer for deserializer device address change).

I²C Address Translation

The device supports I²C address translation for up to two device addresses. Use address translation to assign unique device addresses to peripherals with limited I²C addresses. Source addresses (address to translate

from) are stored in registers 0x09 and 0x0B. Destination addresses (address to translate to) are stored in registers 0x0A and 0x0C.

Configuration Blocking

The device can block changes to its registers. Set CFGBLOCK to make all registers read-only. Once set, the registers remain blocked until the supplies are removed.

Cascaded/Parallel Devices

GMSL supports both cascaded and parallel devices connected through I²C. When cascading or using parallel links, all I²C commands are forwarded to all links. Each link attempts to hold the control channel until it receives an acknowledge/not acknowledge from the remote-side device. It is important to keep the control channel active between links to prevent timeout. If a link is unused, keep the control channel clear by turning on the configuration link, disconnecting the I²C lines, or powering down the unused device.

Dual μ C Control

Most systems use a single microcontroller; however μ Cs can reside on each side simultaneously and trade off in running the control channel. Contention occurs if both μ Cs attempt to use the control channel at the same time. It is up to the user to prevent this contention by implementing a higher level protocol. In addition, the control channel does not provide arbitration between I²C masters on both sides of the link. An acknowledge frame is not generated when communication fails due to contention. If communication across the serial link is not required, the μ Cs can disable the forward and reverse control channel using the FWCCEN and REVCCEN bits (0x04, D[1:0]) in the SerDes. Communication across the serial link is stopped and contention between μ Cs cannot occur.

Device Address

The serializer/deserializer both have a 7-bit-long slave address stored in registers 0x00 and 0x01. The bit following a 7-bit slave address is the R/W bit, which is low for a write command and high for a read command. The default slave address is 0x80. After startup, a microcontroller can reprogram the slave address as needed.

Spread Spectrum

Program the SS bits in the serializer to turn on spread spectrum in the serializer (Table 5). If the deserializer driven by the serializer has programmable spread spectrum, do not enable spread for both at the same time or their interaction cancels benefits. The deserializer tracks the serializer's spread and passes the spread to the deserializer output. Some spread-spectrum amplitudes can only be used at lower PCLKIN frequencies (Table 6). When the spread spectrum is turned on or off, the serial link stops for several microseconds and then restarts in order for the deserializer to lose and relock to the new serial-data stream. Changing the spread-spectrum amplitude does not cause a loss of lock.

Manual Programming of the Spread-Spectrum Divider

By default, autodetection of the PCLKIN operation range guarantees a spread-spectrum modulation frequency within 20kHz to 40kHz. Additionally, manual configuration of the sawtooth divider (SDIV: 0x03,D[5:0]) allows the user to set a modulation frequency (typically 20kHz) according to the PCLKIN frequency.

Equation:

Relation of modulation rate to the PCLKIN frequency:

$$f_M = f_{PCLKIN} / (\text{MOD} \times \text{SDIV})$$

where:

f_M = Modulation frequency

f_{PCLKIN} = PCLKIN frequency

MOD = Modulation coefficient given in Table 7

SDIV = 6-bit SDIV setting, manually programmed by the μC

Table 5. Output Spread

SS	SPREAD (%)
000	Power-up default (no spread spectrum)
001	$\pm 0.5\%$ spread spectrum
010	$\pm 1.5\%$ spread spectrum
011	$\pm 2\%$ spread spectrum
100	No spread spectrum
101	$\pm 1\%$ spread spectrum
110	$\pm 3\%$ spread spectrum
111	$\pm 4\%$ spread spectrum

Table 6. Spread Limitations

BWS = 0 MODE, PCLKIN FREQUENCY (MHz)	BWS = 1 MODE, PCLKIN FREQUENCY (MHz)	SERIAL LINK BIT RATE (MBPS)	AVAILABLE SPREAD RATES
< 33.3 (DBL = 0)	< 25 (DBL = 0)	< 1000	All rates available
< 66.6 (DBL = 1)	< 50 (DBL = 1)		
33.3 to 58 (DBL = 0)	25 to 43.5 (DBL = 0)	≥ 1000	1.5%, 1%, 0.5%
66.6 to 116 (DBL = 1)	50 to 87 (DBL = 1)		

Table 7. Modulation Coefficients and Maximum SDIV Settings

BWS	SPREAD-SPECTRUM SETTING (%)	MODULATION COEFFICIENT (DEC)	SDIV UPPER LIMIT (DEC)
1	1	104	40
	0.5	104	63
	3	152	27
	1.5	152	54
	4	204	15
0	2	204	30
	1	80	52
	0.5	80	63
	3	112	37
	1.5	112	63
	4	152	21
	2	152	42

To program the SDIV setting, first look up the modulation coefficient according to the desired bus-width and spread-spectrum settings. Solve the above equation for SDIV using the desired pixel clock and modulation frequencies. If the calculated SDIV value is larger than the maximum allowed SDIV value in [Table 7](#), set SDIV to the maximum value.

Board Layout

Power-Supply Circuits and Bypassing

The serializer uses an AVDD and DVDD of 1.7V to 1.9V. All inputs and outputs, except for the serial output, derive power from DVDD. Proper voltage-supply bypassing is essential for high-frequency circuit stability.

High-Frequency Signals

Separate the LVCMOS logic signals and CML/coax high-speed signals to prevent crosstalk. Use a four-layer PCB with separate layers for power, ground, CML/coax, and LVCMOS logic signals. Layout STP-PCB traces close to each other for a 100Ω differential characteristic impedance. The trace dimensions depend on the type of trace used (microstrip or stripline).

Note: Two 50Ω PCB traces do not have 100Ω differential impedance when brought close together; the impedance goes down when the traces are brought closer. Use a 50Ω trace for the single-ended output when driving coax. Route the PCB traces for differential CML in parallel to maintain the differential characteristic impedance. Avoid via arrays. Keep PCB traces that make up a differential pair equal in length to avoid skew within the differential pair.

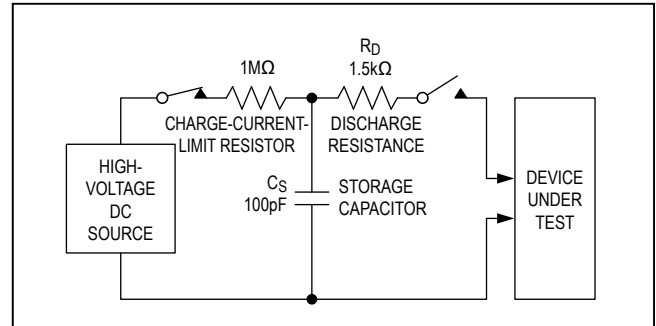

Figure 19. Human Body Model ESD Test Circuit

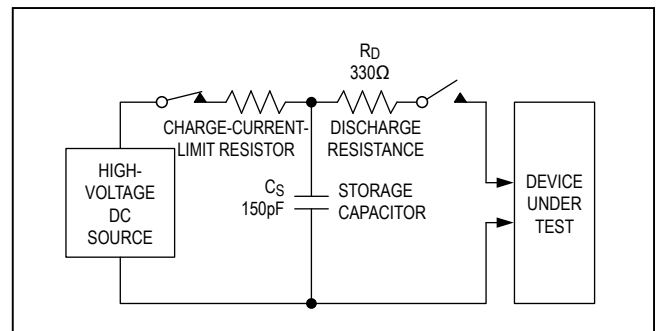

Figure 20. IEC 61000-4-2 Contact Discharge ESD Test Circuit

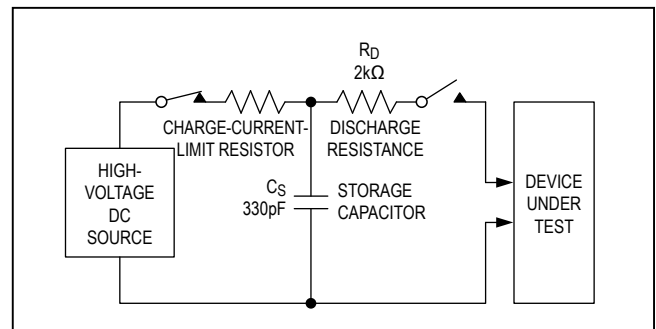

Figure 21. ISO 10605 Contact Discharge ESD Test Circuit

ESD Protection

ESD tolerance is rated for Human Body Model, IEC 61000-4-2, and ISO 10605. The ISO 10605 and IEC 61000-4-2 standards specify ESD tolerance for electronic systems. The serial outputs are rated for ISO 10605 ESD protection and IEC 61000-4-2 ESD protection. All pins are tested for the Human Body Model. The Human Body Model discharge components are CS = 100pF and RD = 1.5kΩ (Figure 19). The IEC 61000-4-2 discharge components are CS = 150pF and RD = 330Ω (Figure 20). The ISO 10605 discharge components are CS = 330pF and RD = 2kΩ (Figure 21).

Compatibility with Other GMSL Devices

The device is designed to pair with the MAX96705–MAX96711 family of devices, but interoperates with any GMSL device. See [Table 8](#) for operating limitations.

Device Configuration and Component Selection

Internal Input Pulldowns

The control and configuration inputs include a pulldown resistor to GND; external pulldown resistors are not needed.

Multifunction GPO/HIM

Functions as the GPO output, and as a configuration pin. On power-up, or when reverting from a power-down state, the pins act as the HIM input. After latching the input state, the pin becomes the GPO output. Connect a configuration input through a 30kΩ resistor to DVDD to set a high level. Leave the configuration input open to set a low level.

I²C Pullup Resistors

The I²C open-drain lines require a pullup resistor to provide a logic-high level. There are tradeoffs between power dissipation and speed, and a compromise may be required when choosing pullup resistor values. Every device connected to the bus introduces some capacitance even when the device is not in operation. I²C specifies 300ns rise times (30% to 70%) for fast mode, which

is defined for data rates up to 400kbps (see the *I²C Port Timing* section in the [AC Electrical Characteristics](#) table for details). To meet the fast-mode rise-time requirement, choose the pullup resistors so that rise time $t_R = 0.85 \times R_{PULLUP} \times C_{BUS} < 300\text{ns}$. The waveforms are not recognized if the transition time becomes too slow. GMSL supports I²C rates up to 1Mbps.

AC-Coupling Capacitors

Voltage droop and the digital-sum variation (DSV) of transmitted symbols cause signal transitions to start from different voltage levels. Because the transition time is fixed, starting the signal transition from different voltage levels causes timing jitter. The time constant for an AC-coupled link needs to be chosen to reduce droop and jitter to an acceptable level. The RC network for an AC-coupled link consists of the CML/coax receiver termination resistor (R_{TR}), the CML/coax-driver termination resistor (R_{TD}), and the series AC-coupling capacitors (C). The RC time constant for four equal-value series capacitors is $(C \times (R_{TD} + R_{TR}))/4$. R_{TD} and R_{TR} are required to match the transmission-line impedance (usually 100Ω differential, 50Ω single-ended). This leaves the capacitor selection to change the system time constant. Use 0.2μF or larger high-frequency, surface-mount ceramic capacitors with sufficient voltage rating to withstand a short to battery, to pass the lower speed reverse control-channel signal. Use capacitors with a case size less than 3.2mm x 1.6mm to have lower-parasitic effects to the high-speed signal.

Table 8. Feature Compatibility

SERIALIZER FEATURE	GMSL DESERIALIZER
HSYNC/VSYNC Encoding	If feature not supported in the deserializer, turn off in the serializer.
I ² C to I ² C	If feature not supported in the deserializer, do not use control channel.
CRC Error Detection	If feature not supported in the deserializer, turn off in the serializer.
Double Input	If feature not supported in the deserializer, data is output as a single word at half the input frequency. Use crossbar switch to correct input mapping.
Coax	If feature not supported in the deserializer, connect unused serial input through 200nF and 50Ω in series to AVDD, and set the reverse control-channel amplitude to 100mV.
I ² S Encoding	If supported in the deserializer, disable I ² S in the deserializer.
High-Immunity Mode	If feature not supported in the deserializer, turn off in the serializer.
Low-Speed Mode	If supported in the deserializer, set DRS to 0 in the deserializer.

Table 9. Suggested Connectors and Cables for GMSL

VENDOR	CONNECTOR	CABLE	TYPE
Rosenberger	59S2AX-400A5-Y	Dacar 302	Coax
Rosenberger	D4S10A-40ML5-Z	Dacar 538	STP
Nissei	GT11L-2S	F-2WME AWG28	STP
JAE	MX38-FF	A-BW-Lxxxxx	STP

Cables and Connectors

Interconnect for CML typically has a differential impedance of 100Ω. Use cables and connectors that have matched differential impedance to minimize impedance discontinuities. Coax cables typically have a characteristic impedance of 50Ω; contact the factory for 75Ω operation). [Table 9](#) lists the suggested cables and connectors used in the GMSL link.

PRBS

The serializer includes a PRBS pattern generator that works with bit-error verification in the deserializer. To run the PRBS test, set PRBSEN = 1 (0x04, D5) in the deserializer, then in the serializer. To exit the PRBS test, set PRBSEN = 0 (0x04, D5) in the serializer. The deserializer automatically ends PRBS checking and sets the PRBS_OK bit high. During PRBS mode, the forward control channel is not available except to exit PRBS mode if autoacknowledge is enabled in the deserializer; otherwise, the remote control channel is not available at all.

To run the PRBS with a 3Gbps SerDes, first set the PRBS_TYPE bit = 0 in the MAX967XX. Then set PRBSEN = 1 (0x04, D5) in the serializer and then in the deserializer. To exit the PRBS test, set PRBSEN = 0 (0x04, D5) in the deserializer, then in the serializer.

During PRBS test, ERRB function changes to reflect PRBS errors only. ERRB goes low when any PRBS errors occur. ERRB goes high when the PRBS error counter is reset when PRBS_ERR is read. Normal ERRB function resumes when exiting the PRBS test.

GPI/GPO

GPO on the serializer follows GPI transitions on the deserializer. By default, the GPI-to-GPO delay is 0.35ms (max). Keep the time between GPI transitions to a minimum 0.35ms. GPI_IN the deserializer stores the GPI input state. GPO is low after power-up. The μC can set GPO by writing to the SET_GPO register bit.

Fast Detection of Loss-of-Lock

A measure of link quality is the recovery time from loss-of-synchronization. The host can be quickly notified of loss-of-lock by connecting the deserializer's LOCK output to

the GPI input. If other sources use the GPI input, such as a touch-screen controller, the μC can implement a routine to distinguish between interrupts from loss-of-sync and normal interrupts. Reverse control-channel communication does not require an active forward link to operate and accurately tracks the LOCK status of the GMSL link. LOCK asserts for video link only and not for the configuration link.

Providing a Frame Sync (Camera Applications)

The GPI and GPO provide a simple solution for camera applications that require a frame-sync signal from the ECU (e.g., surround-view systems). Connect the ECU frame-sync signal to the GPI input and connect the GPO output to the camera frame-sync input. GPI/GPO have a typical delay of 275μs. Skew between multiple GPI/ GPO channels is 115μs (max). If a lower skew signal is required in legacy mode, connect the camera's frame-sync input to one of the serializer's GPIOs and use an I²C broadcast-write command to change the GPIO output state. This has a maximum skew of 1.5μs, independent from the used I²C bit rate.

Entering/Exiting Sleep Mode

The procedure for entering and exiting sleep mode depends on the location of the microcontroller, and the type of control-channel interface used. If wake up from a remote (deserializer) side microcontroller is not needed or desired, set the DIS_RWAKE bit = 1 to shut down remote wake-up for further power savings.

To enter sleep mode, set SLEEP = 1. The device sleeps after 8ms. To wake up the device, send an arbitrary control-channel command to the serializer (the serializer does not send an acknowledge), wait for 5ms for the chip to power up and then set SLEEP = 0 to make the wake-up permanent.

To wake up the device, send an arbitrary control-channel command to the serializer (the serializer does not send an acknowledge). Wait for 5ms for the chip to power up and then set SLEEP = 0 to make the wake-up permanent. The deserializer wakes up and clears its SLEEP bit when serialization is enabled and it locks to the serializer.

Typical Application Circuits

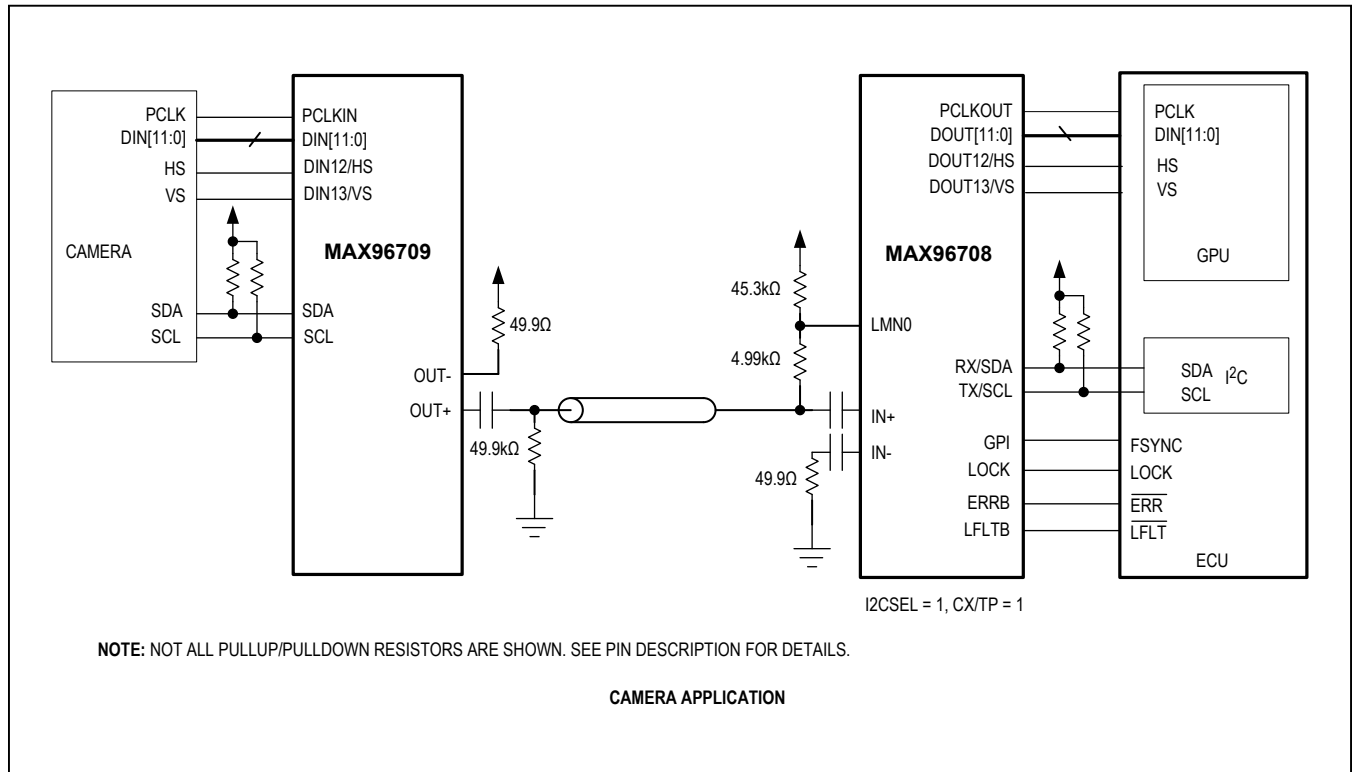

Ordering Information

PART NUMBER	TEMP RANGE	PIN-PACKAGE
MAX96709GTG+	-40°C to +115°C	24 TQFN-EP*
MAX96709GTG/V+	-40°C to +115°C	24 TQFN-EP*
MAX96709GTG/V+T	-40°C to +115°C	24 TQFN-EP*
MAX96709GTG+T	-40°C to +115°C	24 TQFN-EP*

+Denotes a lead(Pb)-free/RoHS-compliant package.

/V denotes an automotive qualified product.

*EP = Exposed pad.

T = Tape and reel.

Revision History

REVISION NUMBER	REVISION DATE	DESCRIPTION	PAGES CHANGED
0	2/16	Initial release	—

For pricing, delivery, and ordering information, please contact Maxim Direct at 1-888-629-4642, or visit Maxim Integrated's website at www.maximintegrated.com.

Maxim Integrated cannot assume responsibility for use of any circuitry other than circuitry entirely embodied in a Maxim Integrated product. No circuit patent licenses are implied. Maxim Integrated reserves the right to change the circuitry and specifications without notice at any time. The parametric values (min and max limits) shown in the Electrical Characteristics table are guaranteed. Other parametric values quoted in this data sheet are provided for guidance.