



IQS229 Datasheet

Single Channel Capacitive Proximity/Touch Controller for SAR Applications

The IQS229 ProxSense® IC is a self-capacitance controller designed for applications that are required to meet SAR regulations. The IQS229 can also be used to detect a long term presence as a movement detector. The IQS229 operates standalone and can be configured via digital inputs.

Features

- SAR compliance in mobile devices according to the IEC 62209-2 ed1.0 standard and the FCC standard (KDB 616217 - D04 SAR for laptop and tablets v01)
- Failsafe firmware/hardware design
- Automatic Tuning (ATI)
- On-chip movement detection algorithm
- Minimal external components
- Standalone operation
- 25mm detection distance
- Up to 60pF sensor load
- Internal Capacitor Implementation (ICI) – reference capacitor on-chip
- Configuration settings via external pins
 - Activation threshold
 - Movement filter threshold



- Activation time-out
- Supply voltage: 1.8V to 3.6V
- Low power consumption: 30uA (sub 10uA in sleep mode)
- Low profile DFN10 package (3x3)

Applications

- SAR detection for tablets and mobile phones
- SAR detection for wireless charging stations (operating frequency > 100 MHz)
- SAR detection for USB dongle-type devices
- Movement detection devices (anti-theft)
- Reed relay replacement
- White goods and appliances
- Human Interface Devices
- Proximity activated backlighting
- Applications with long-term activation

Available Packages

T _A	DFN10 (3x3)
-40°C to 85°C	IQS229

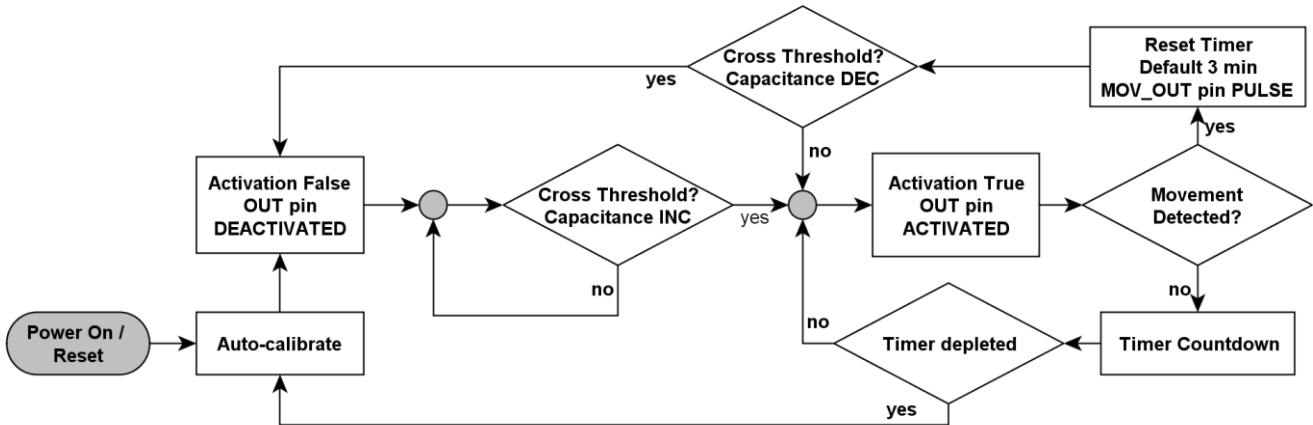

Figure 1.1 Flow diagram of the IQS229 user interface

1 Overview

1.1 Device

The IQS229 is a device tailored for long-term proximity or touch activations. It offers two Boolean outputs, one with an activation threshold for large capacitive shifts and the other with a threshold for small movements even during a normal activation.

1.1.1 Normal operation

With a normal activation (hand brought close) the output will become active. The output will de-activate as soon as the action is reversed (hand taken away). In addition a separate movement output will become active when movement is detected according to a movement threshold. Movement may be detected before the normal threshold is crossed. Movement

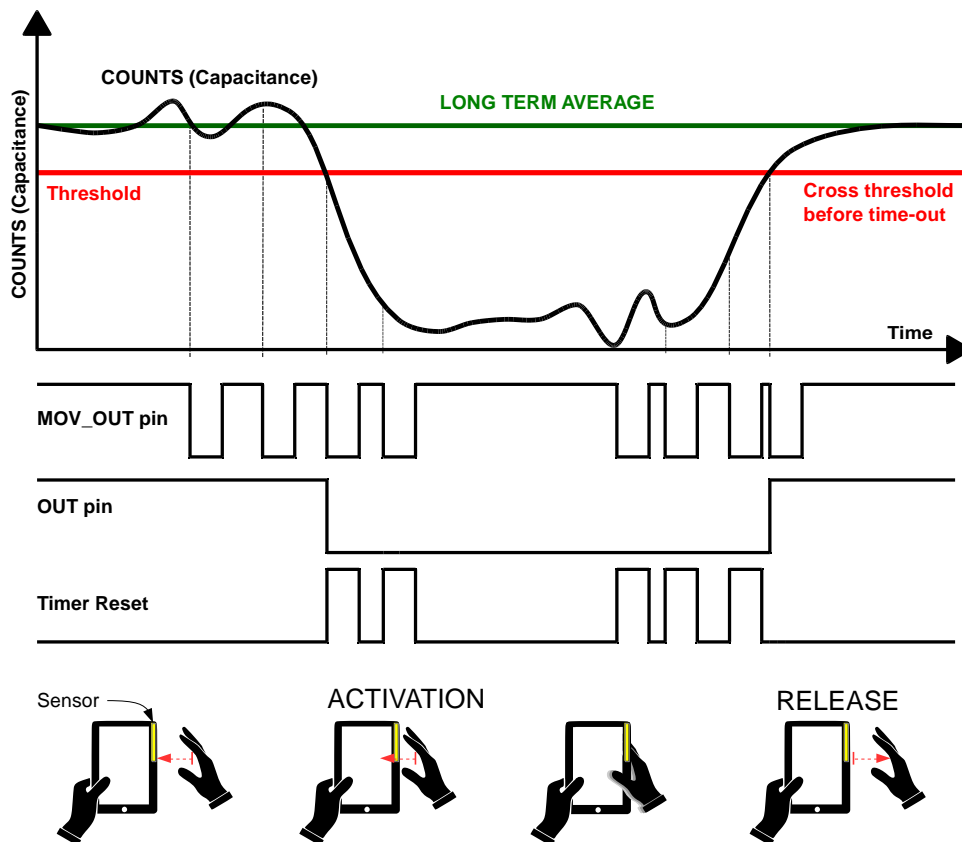

Figure 1.2 Plot of IQS229 streaming data along with the digital response

detection is done via a completely separate digital filter while improving the efficiency of the sensor output (timer reset on movement).

1.1.2 Long term activation

In a normal activation the output will stay active for as long as movements are detected. A time-out timer (configurable time) will be reset with each movement.

1.1.3 Long term recovery

When changing the sensor capacitive environment, the sensor will adapt to the new environment. If the new environment decreases capacitance (wooden table to air), the sensor will rapidly adapt in order to accept new human activations. If the new environment increases capacitance (like air to steel table), the sensor will remain in activation until a time-out occurs (as seen

time-out with no movement around the sensor.

1.1.4 Fail-safe features

For SAR application the device includes various features to ensure fail-safe operation:

- Active low with pull-down resistor ensures activation with failure (at the cost of leakage current with no activation)
- Hard reset by pulling the movement pin low. This allows for a restart and device status check.
- Characteristic toggle on output pin with power-up and soft reset to check if the IC is functioning.

1.1.5 Integrated features

The device includes an internal voltage

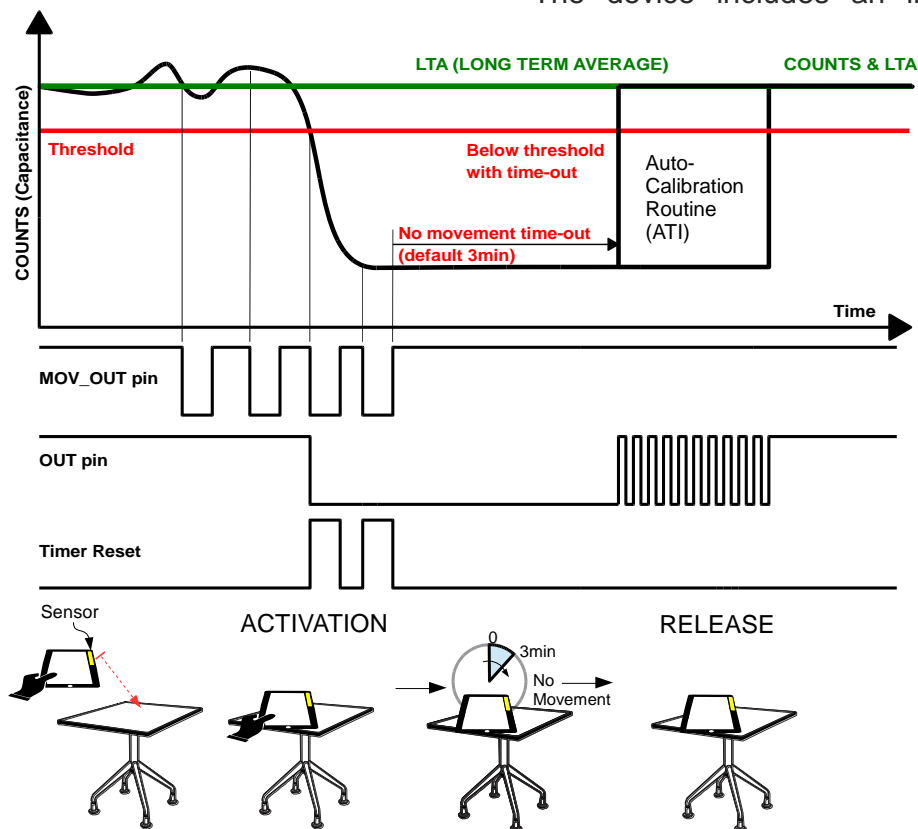

Figure 1.3 Example of a time-out event with re-calibration

in Figure 1.3) or until the device is returned to its previous environment.

When the timer runs out, the output will be de-activated. Re-calibration is possible after de-activation because the timer will only

regulator and reference capacitor (C_s).

Various advanced signal processing techniques are combined for creating a robust solution.



These techniques include:

- Movement detection filter (to release an activation in the case of inactivity)
- Advanced noise filtering on incoming sample stream
- Superior methods of parasitic capacitance compensation while preserving sensitivity

1.1.6 Data streaming

A 1-wire data streaming interface is offered for debugging purposes. Streaming mode and stand-alone mode are interchangeable via simple hardware configurations. This is offered because streaming may be useful at various stages of a design.

Streaming mode is offered through a simple pull-up resistor on the standard digital output pin. Standalone mode is enabled through a pull-down resistor on this pin.

1.1.7 Hardware configuration options

Various configuration options are made available through digital input pins. These include:

- the activation threshold,
- inactivity time-out settings
- and movement threshold selection

Special device configurations are only available on special request and can be done by setting one time programmable (OTP) options. These will only be available on special orders, aiming to meet most needs with configuration pins.

1.1.8 Automatic Calibration

Proven Automatic Tuning Implementation (ATI) algorithms are used to calibrate the device to the sense electrode. This algorithm is optimised for applications where a fixed detection distance (in mid-air) is required for failure safe detection.

1.1.9 Capacitive sensing method

The *charge transfer* method of capacitive sensing is employed on the IQS229. (The charge transfer principle is thoroughly

described in the application note: "[AZD004 - Azoteq Capacitive Sensing](#)".)

1.2 Operation

1.2.1 Device Setup

Typical device use allows for very little to no setup before integration. A few characteristics may be fixed via four of the IQS229 pins - each having three possible pin states. This should suffice for most simple and intended applications.

Note: It is important that any pins connected to an MCU are kept high impedance (Hi-Z) from the MCU side during power-up. This is to ensure correct start-up especially with a high impedance strap resistor on the OUT pin for standalone power-up.

1.2.2 Configuration pin setup

Configuration options are selected by:

- Floating a pin
- pull-up resistor
- pull-down resistor

See section 4 for choosing a specific configuration. For configurations not covered by the configuration pins, custom ICs will be available in bulk orders. Information on custom configurations are available on special request.

At start-up device parameters are read and set according to the configuration pin states. Configuration pins are then changed to digital outputs and are written to the state that was read (for minimising current consumption¹). Floating pins are written low. After configuration, calibration routines are run which can be run periodically in order to run with optimal sensitivity.

1.2.3 Movement filters

The movement filter runs continually and the dedicated digital output will activate for

¹ Known issue & workaround: The THRO and TIMER pin are written low when pulled high. Use a 1MΩ on these pins to limit current consumption.



a time depending on the intensity of the movement.

1.2.4 External control

The movement output (optional line to connect to master device) can be used to signal a “reseed” (t_{reseed}) or “sleep mode” (t_{sleep}). A short pulse will force the reference counts (long-term average) to match the actual counts (capacitance of sensor). By writing the pin low for a longer time, will force the IC into sleep mode for low current consumption (2uA + required pull-up on movement pin). When sleep mode is entered, the IQS229 will reset upon wake-up.

In sleep mode the output pin is written low in order to minimise current consumption.

1.2.5 Low power options

As mentioned in the section above, a charge halt will initiate the sleep mode. The device will reset and return to normal power as soon as the line is released.

1.3 Applicability

All specifications, except where specifically mentioned otherwise, provided by this datasheet are applicable to the following ranges:

Temperature: -40C to +85C

Supply voltage (V_{DDHI}): 1.8V to 3.6V

1.4 Passing the SAR qualification testing with the IQS229

For design information on passing the SAR qualification testing with Azoteq movement based sensors, please see the application note: [“AZD073 SAR qualification with Azoteq movement-based sensors”](#)



2 Packaging and Pin-Out

The IQS229 is available in a DFN10 (3x3) package.

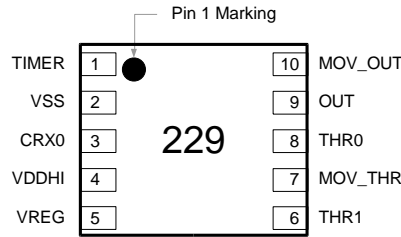

Figure 2.1 IQS229 pin-out (DFN10 package)

Table 2.1 Pin-out description

IQS229 in DFN10			
Pin	Name	Type	Function
1	TIMER	Digital Input	“No movement” timeout period selection
2	VSS	Signal GND	
3	CRX0	Sense electrode	Connect to conductive area intended for sensor
4	VDDHI	Supply Input	Supply:1.8V – 3.6V
5	VREG	Regulator output	Requires external capacitor
6	THR1	Digital Input	Threshold1 selection (fine)
7	MOV_THR	Digital Input	Movement Threshold selection
8	THR0	Digital Input	Threshold0 selection (coarse)
9	OUT	Digital Output/Input	Activation output (active low) / 1-wire Data / Input at power-up to determine standalone or streaming
10	MOV_OUT	Digital Output/Input	Movement output (active low) / Input for reseed and charge halt

3 Reference Design

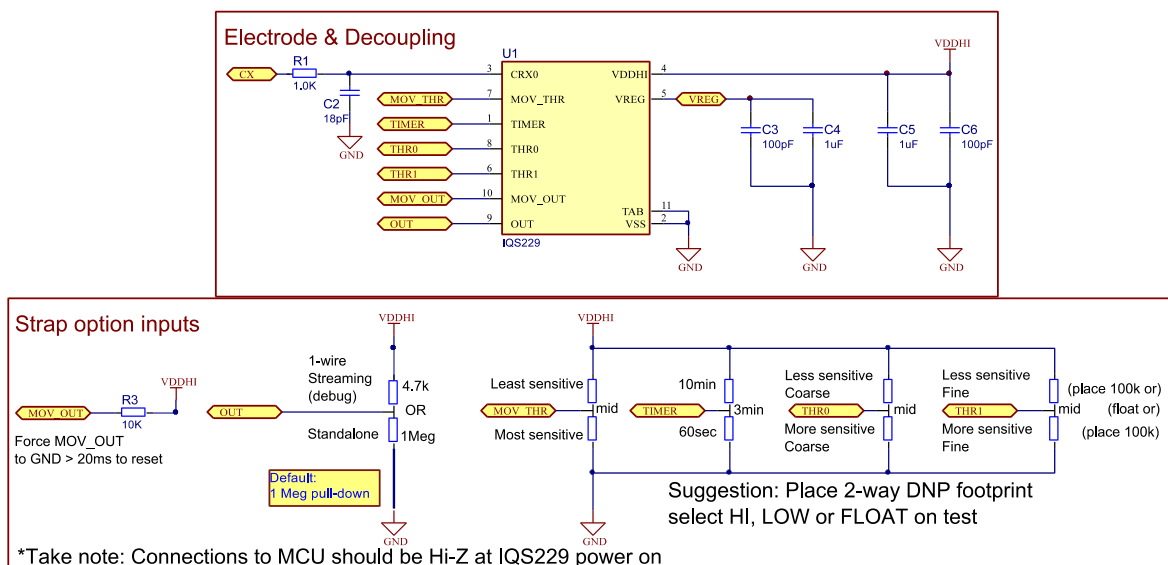

Figure 3.1 Reference schematic

4 Configuration Options

4.1 Activation Threshold

The threshold adjustment is offered through two configuration pins.

THR0 is a first level of threshold adjustment. THR1 is a second level for refining the threshold. See Table 4.1 for details on choosing the threshold

Table 4.1 Threshold adjustment guide

L = LOGIC LOW, H = LOGIC HIGH, F = FLOAT								
THR0 (pin 8)								
L	L	L	F	F	F	H	H	H
THR1 (pin 6)								
L	F	H	L	F	H	L	F	H
Corresponding Threshold Level								
0	1	2	3	4	5	6	7	8
Entry Threshold Ratio								
1/ 512	2/ 512	4/ 512	6/ 512	10/ 512	14/ 512	18/ 512	24/ 512	32/ 512
Corresponding Entry Threshold Countsⁱ								
3 ⁱⁱ	4	9	14	23	32	42	56	74
Corresponding Release Threshold Counts (counts from reference)								
3	3	7	11	18	24	32	42	56
◀ More sensitive Less sensitive ▶								

It is important to note that most sensitive settings are heavily dependent on design factors influencing SNR. These may be in order where fail-safe activations are

ⁱ Assuming a target of 1200 counts, threshold may be more for a larger amount, and less for a smaller amount (usually by only 1 count)

ⁱⁱ Threshold calculations limit any threshold value to always be larger than 2 counts

required, but is not recommended for activation critical applications.

4.2 Timer Settings

Large environmental shifts (capacitance increases or decreases) are regarded as activations. Such conditions are intelligently cleared via the movement filter and timer. The timer would reset with each detected movement. If no movement is detected for the duration of the timer, the activation will be cleared. A few options exist for the duration of this timer.

Timer options are summarized in the table below:

TIMER (pin 1)	Time-out
Low	60sec
Float	3min
High	10min

For custom timers the IQS229 makes it possible to distinguish between a threshold release and a no-movement release. The master device may then override the IQS229 output until the custom master timer has expired.

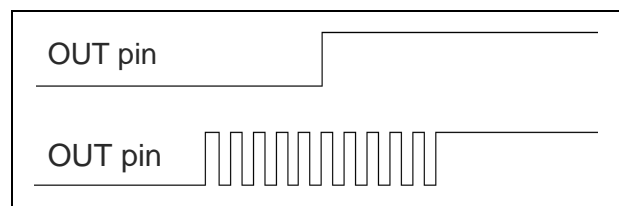

Figure 4.1 Normal release with threshold crossing (top), time-out release after no-movement condition (bottom)



4.4 Human movement filter threshold

The MOV_THR pin offers adjustment of the threshold used to determine if a movement event should be triggered. From a default setting (pin FLOATING), the threshold can be increased or decreased by a percentage of the capacitive sensor operating point (long-term average).

MOV_THR (pin 7)	Movement Threshold
Low	More sensitive
Float	Default
High	Less sensitive



5 Design Considerations

5.1 Power Supply and PCB Layout

Azoteq IC's provide a high level of on-chip hardware and software noise filtering and ESD protection (refer to application note "[AZD013 – ESD Overview](#)"). Designing PCB's with better noise immunity against EMI, FTB and ESD in mind, it is always advisable to keep the critical noise suppression components like the de-coupling capacitors and series resistors in Figure 3.1. as close as possible to the IC. Always maintain a good ground connection and ground pour underneath the IC. For more guidelines please refer to the relevant application notes as mentioned in the next section.

5.2 Design Rules for Harsh EMC Environments

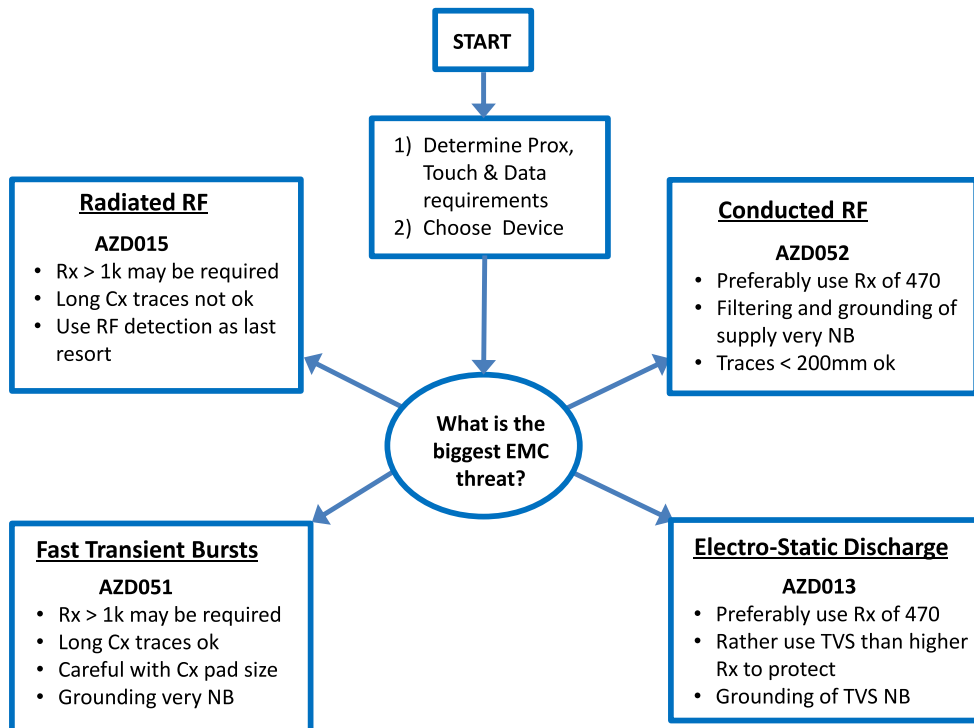

Applicable application notes: AZD013, AZD015, AZD051, and AZD052.

5.3 High Sensitivity

Through patented design and advanced signal processing, the device is able to provide extremely high sensitivity to detect proximity. This enables designs to detect proximity at distances that cannot be equaled by most other products. When the device is used in environments where high levels of noise or floating metal objects exist, a reduced proximity threshold is proposed to ensure reliable functioning of the sensor. The high sensitivity also allows the device to sense through overlay materials with low dielectric constants, such as wood or porous plastics.

For more guidelines on the layout of capacitive sense electrodes, please refer to application note "[AZD008 - Design Guidelines for Touch Pads](#)", available on the Azoteq web page: www.azoteq.com.

6 1-Wire data streaming mode

The IQS229 has the capability to stream data over the OUT pin to a master controller or debugging device. This provides the designer with the capability to obtain the parameters within the device in order to aid design into applications. Data streaming is performed as a 1-wire data protocol on the OUT pin. The function of this pin is therefore lost when the device is placed in streaming mode. The function of the MOV_OUT pin remains. The MOV_OUT pin may now be used to only read streaming data when movements occur. This enables 1-wire data processing only on the occurrence of movement events.

Data streaming can be enabled as shown in Figure 3.1 by simply placing a strong pull-up resistor on the OUT pin (4.7kΩ is recommended). Debugging and qualification during production may be done by simply probing the output pin with a strong pull-up while the weaker pull-down (1MΩ) is placed on

the PCB. This will put the standalone module in 1-wire streaming mode.

Data streaming is initiated by the IQS229. When data streaming is enabled data is sent following each charge cycle.

Figure 6.1 Illustrates the communication protocol for initialising and sending data with the 1 wire communication protocol.

1. Communication is initiated by a START bit. Bit defined as a low condition for t_{START} .
2. Following the START bit, is a synchronisation byte ($T_{INIT} = 0xAA$). This byte is used by the MCU for clock synchronisation.
3. Following T_{INIT} the data bytes will be sent. 20 bytes will be sent after each charge cycle.
4. Each byte sent will be preceded by a START bit and a STOP bit will follow every byte.
5. STOP bit indicated by taking pin 1 high. The STOP bit does not have a defined period.

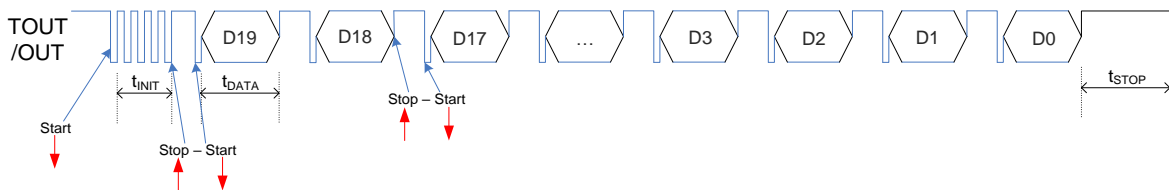

Figure 6.1 1-wire data streaming mode



The following table defines the data streamed from the IQS229 device during streaming mode.

Table 6.1 Byte definitions for 1-wire streaming mode

Byte	Bit	Value
0	7:0	System Flags
	7	Activation
	6	Movement
	5	Timer Active
	4	Filter Halt
	3	Is channel 0
	2	ATI tuning busy
	1	Noise detected
0	Zoom	
1	15:8	CH0 CS High byte
2	23:16	CH0 CS Low byte
3	31:24	CH0 LTA High byte
4	39:32	CH0 LTA Low byte
5	47:40	CH1 CS High byte
6	55:48	CH1 CS Low byte
7	63:56	CH1 LTA High byte
8	71:64	CH1 LTA Low byte
9	79:72	Movement Filter
10	87:80	Movement Filter
11	95:88	Entry threshold high byte
12	103:96	Entry threshold low byte
13	111:104	Exit threshold high byte
14	119:112	Exit threshold low byte
15	127:120	Strap configuration
	127:124	Activation threshold
	123:122	Timer setting
	121:220	Movement threshold
16	135:128	Multiplier channel 0
17	143:136	Multiplier channel 1
18	151:144	Parasitic capacitance compensation (PCC) channel 0
19	159:152	Parasitic capacitance compensation (PCC) channel 1

Azoteq provides a graphic user interface to evaluate the user interface and debug current designs.

Sample code available: "AZD017 - IQS127 1-Wire Protocol SAMPLE CODE" This code represents the same protocol and only needs to be adapted for the longer data stream.

7 Typical Application

7.1 Minimizing Resistor straps

Component count is an important factor for applications with limited space and cost constraints. This section addresses this with a slightly more complex configuration than the standard reference design. This configuration should lead the designer to a safe minimal component design.

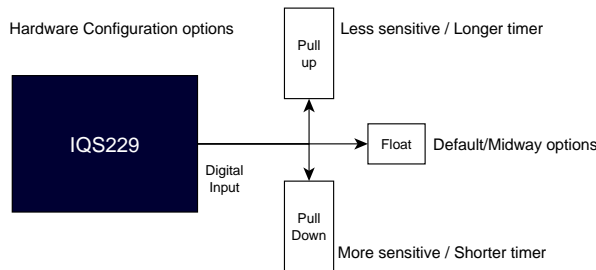

Figure 7.1 IQS229 configuration pin options

Table 7.1 Table of constraints for resistor strap optimization

Resistor strap state	Applicable pins	Output state after start-up	Resistor value	Current consumption	Combination strap
Pull down	All input pins	Written low when pulled low	$1k\Omega \leq R \leq 2M\Omega$	Only at power-on	Yes, all pins
Pull up	THR0 and TIMER	Written low when pulled high	$1M\Omega \leq R \leq 2M\Omega$	Continuous	Applicable pins may be combined
Pull up	THR1 and MOV_THR	Written high when pulled high	$1k\Omega \leq R \leq 2M\Omega$	Only at power-on	Applicable pins may be combined

Figure 7.2 shows the reference design for a minimal resistor layout. With a fixed design, a minimum of 0 strap resistors and maximum of 3 strap resistors are expected.

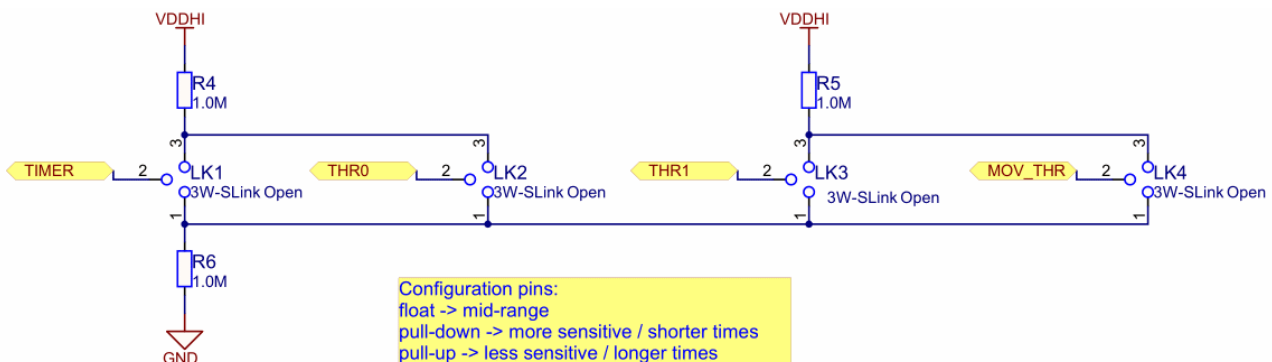

Figure 7.2 Minimal resistor strap configuration



8 Specifications

8.1 Absolute maximum ratings

The following absolute maximum parameters are specified for the device:

Exceeding these maximum specifications may cause damage to the device.

- Operating temperature -40°C to 85°C
- Supply Voltage (VDDHI – VSS) 3.6V
- Maximum pin voltage VDDHI + 0.5V (may not exceed VDDHI max)
- Maximum continuous current (for specific Pins) 10mA
- Minimum pin voltage VSS - 0.5V
- Minimum power-on slope 100V/s
- ESD protection ±8kV (Human body model)
- Package Moisture Sensitivity Level (MSL) 1

Table 8.1 IQS229 General Operating Conditions¹

DESCRIPTION	Conditions	PARAMETER	MIN	TYP	MAX	UNIT
Supply voltage		V _{DDHI}	1.8	3.3V	3.6	V
Internal regulator output	1.8 ≤ V _{DDHI} ≤ 3.6	V _{REG}	1.62	1.7	1.79	V
Default Operating Current	3.3V	I _{IQS229NP}	-	100		μA
Low Power Setting 1*	3.3V, LP=32	I _{IQS229LP32}	-	<40		μA
Low Power Setting 2*	3.3V, LP=64	I _{IQS229LP64}	-	<20		μA
Low Power Setting 3*	3.3V, LP=256	I _{IQS229LP256}	7 (1.8V)	10 (3.3V)	12 (3.6V)	μA

*LP interval period = Low power value (LP) x 1ms

Table 8.2 Start-up and shut-down slope Characteristics

DESCRIPTION	Conditions	PARAMETER	MIN	MAX	UNIT
Power On Reset	V _{DDHI} Slope ≥ 100V/s @25°C	POR		1.6	V
Brown Out Detect	V _{DDHI} Slope ≥ 100V/s @25°C	BOD	1.05		V

¹ Operating current shown in this datasheet does include power dissipation through the recommended 1MΩ strapping resistor on the OUT pin for failsafe modes.



Table 8.3 Digital input trigger levels

DESCRIPTION	Conditions	PARAMETER	MIN	TYPICAL	MAX	UNIT
MOV_OUT pin OUT pin	VDD = 3.3V	Input low level voltage	1.19	1.3	1.3	V
THR0 pin THR1 pin MOV_THR pin TIMER pin	VDD = 3.3V	Input low level voltage	0.73	0.9	1.55	V
All digital inputs	VDD = 1.8V	Input low level voltage	0.54	0.6	0.76	V
All digital inputs	VDD = 1.8V	Input high level voltage	0.9	1.0	1.2	V
All digital inputs	VDD = 3.3V	Input high level voltage	1.90	2.1	2.20	V

Table 8.4 Digital output levels

DESCRIPTION	Conditions	PARAMETER	@1mA	@10mA	UNIT
Output voltage low	VDDHI = 3.3V	V _{OL}	0.01	0.1	V
Output voltage high	VDDHI = 3.3V	V _{OH}	VDDHI - 0.02	VDDHI - 0.2	V

Table 8.5 MOV_OUT pin input signal characteristic

DESCRIPTION	Conditions	PARAMETER	MIN	MAX	UNIT
Input signal for reseed instruction	MOV_OUT pin low	t _{reseed}	20	40	ms
Input signal for sleep instruction	MOV_OUT pin low	t _{sleep}	80	-	ms

9 Package information

Table 9.1 DFN-10 Package dimensions (bottom)

Dimension	[mm]
A	3 ±0.1
B	0.5
C	0.25
D	n/a
F	3 ±0.1
L	0.4
P	2.4
Q	1.65

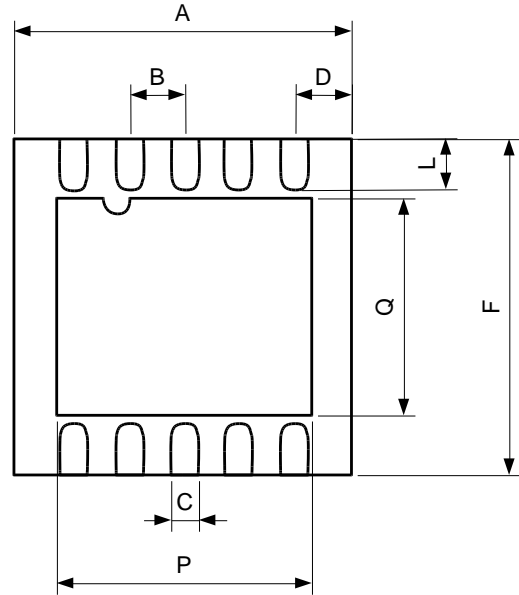

Figure 9.1 DFN-10 Package dimensions (bottom view)

Table 9.2 DFN-10 Package dimensions (side)

Dimension	[mm]
G	0.05
H	0.65
I	0.7-0.8

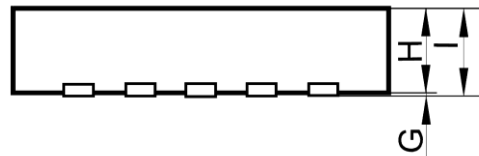

Figure 9.2 DFN-10 Package dimensions (side)

Table 9.3 DFN-10 Landing dimensions

Dimension	[mm]
A	2.4
B	1.65
C	0.8
D	0.5
E	0.3
F	3.2

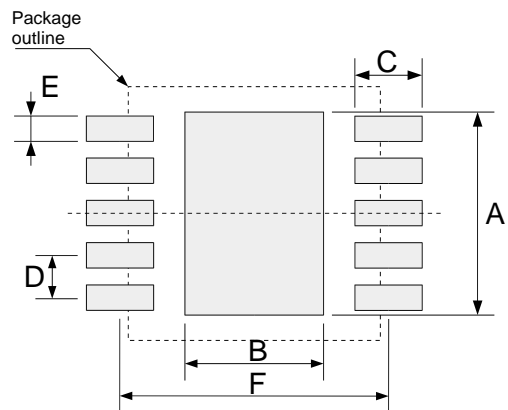

Figure 9.3 DFN-10 Landing dimensions



10 Ordering and Part-number Information

10.1 Ordering Information

Please check stock availability with your local distributor.

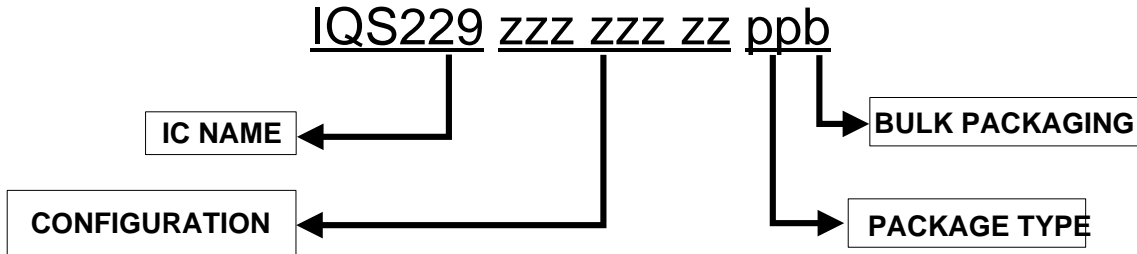

CONFIGURATION	zzz zzz zz	=	IC configuration (hexadecimal) Default 000 000 00 (other configurations available on special request)
PACKAGE TYPE	DN	=	DFN(3x3)-10
BULK PACKAGING	R	=	Reel (3000pcs/reel) – MOQ = 3000pcs MOQ = 1 reel (orders shipped as full reels)

10.2 Device Numbering Convention

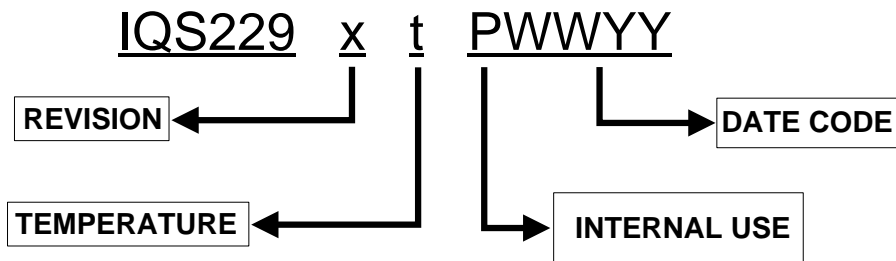

REVISION	x	=	IC Revision Number
TEMPERATURE RANGE	t	=	-40°C to 85°C (Industrial)
DATE CODE	P	=	Internal use
	WWYY	=	Batch number



Revision History

Revision Number	Description	Date of issue
V0.9	Draft revision	22 August 2013
V0.9.1	Pre-Release	1 October 2013
V1.0	Release	7 October 2013
V1.1	Update: Known issue and workaround added to section 1.2.2. Current consumption figures updated.	21 November 2013
V1.2	Digital input trigger level data added	3 February 2014
V1.3	Figure 9.1 corrected – top view changed to bottom view Movement figures Figure 1.2 and Figure 1.3 updated to show the practical case	22 May 2014
V1.4	Package MSL rating updated Section on minimizing resistor straps added. Figure 1.2 and Figure 1.3 updated to be more intuitive	30 May 2014
V1.5	Table 4.1 updated to show related counts for activation and release. Figure 9.3 updated to show correct relation to package outline	14 Jul 2014
V1.6	Document contact information updated	4 Aug 2014
V1.7	Last page contact & patent information updated Reseed/Sleep instruction timing specified	10 Apr 2015
v1.8	Updated Electrical Specifications	15 October 2015
v1.9	Digital output voltage levels added	8 March 2016

**Appendix A Contact Information**

	USA	Asia	South Africa
Physical Address	6507 Jester Blvd Bldg 5, suite 510G Austin TX 78750 USA	Rm2125, Glittery City Shennan Rd Futian District Shenzhen, 518033 China	109 Main Street Paarl 7646 South Africa
Postal Address	6507 Jester Blvd Bldg 5, suite 510G Austin TX 78750 USA	Rm2125, Glittery City Shennan Rd Futian District Shenzhen, 518033 China	PO Box 3534 Paarl 7620 South Africa
Tel	+1 512 538 1995	+86 755 8303 5294 ext 808	+27 21 863 0033
Fax	+1 512 672 8442		+27 21 863 1512
Email	info@azoteq.com	linayu@azoteq.com.cn	info@azoteq.com

Please visit www.azoteq.com for a list of distributors and worldwide representation.

The following patents relate to the device or usage of the device: US 6,249,089 B1; US 6,621,225 B2; US 6,650,066 B2; US 6,952,084 B2; US 6,984,900 B1; US 7,084,526 B2; US 7,084,531 B2; US 7,265,494 B2; US 7,291,940 B2; US 7,329,970 B2; US 7,336,037 B2; US 7,443,101 B2; US 7,466,040 B2 ; US 7,498,749 B2; US 7,528,508 B2; US 7,755,219 B2; US 7,772,781 B2; US 7,781,980 B2; US 7,915,765 B2; US 7,994,726 B2; US 8,035,623 B2; US RE43,606 E; US 8,288,952 B2; US 8,395,395 B2; US 8,531,120 B2; US 8,659,306 B2; US 8,823,273 B2; EP 1 120 018 B2; EP 1 206 168 B1; EP 1 308 913 B1; EP 1 530 178 A1; EP 2 351 220 B1; EP 2 559 164 B1; CN 1330853; CN 1783573; AUS 761094; HK 104 1401

IQ Switch[®], SwipeSwitch[™], ProxSense[®], LightSense[™], AirButton[™], ProxFusion[™], Crystal Driver[™] and the  logo are trademarks of Azoteq.

The information in this Datasheet is believed to be accurate at the time of publication. Azoteq uses reasonable effort to maintain the information up-to-date and accurate, but does not warrant the accuracy, completeness or reliability of the information contained herein. All content and information are provided on an "as is" basis only, without any representations or warranties, express or implied, of any kind, including representations about the suitability of these products or information for any purpose. Azoteq disclaims all warranties and conditions with regard to these products and information, including but not limited to all implied warranties and conditions of merchantability, fitness for a particular purpose, title and non-infringement of any third party intellectual property rights. Azoteq assumes no liability for any damages or injury arising from any use of the information or the product or caused by, without limitation, failure of performance, error, omission, interruption, defect, delay in operation or transmission, even if Azoteq has been advised of the possibility of such damages. The applications mentioned herein are used solely for the purpose of illustration and Azoteq makes no warranty or representation that such applications will be suitable without further modification, nor recommends the use of its products for application that may present a risk to human life due to malfunction or otherwise. Azoteq products are not authorized for use as critical components in life support devices or systems. No licenses to patents are granted, implicitly, express or implied, by estoppel or otherwise, under any intellectual property rights. In the event that any of the abovementioned limitations or exclusions does not apply, it is agreed that Azoteq's total liability for all losses, damages and causes of action (in contract, tort (including without limitation, negligence) or otherwise) will not exceed the amount already paid by the customer for the products. Azoteq reserves the right to alter its products, to make corrections, deletions, modifications, enhancements, improvements and other changes to the content and information, its products, programs and services at any time or to move or discontinue any contents, products, programs or services without prior notification. For the most up-to-date information and binding Terms and Conditions please refer to www.azoteq.com.

www.azoteq.com/ip

info@azoteq.com