



Thin-Film Cascadable Amplifier 5 to 1000 MHz

Technical Data

UTO/UTC 1054 Series

Features

- **Frequency Range: 5 to 1000 MHz**
- **High Gain: 24 dB (Typ)**
- **Low Noise Figure: 3.5 dB (Typ)**
- **5-Volt Supply**
- **High Dynamic Range**
- **Temperature Compensated**

Applications

- **IF/RF Amplification**
- **5 Volt Systems**

Description

The 1054 Series is a 5-volt two-stage, thin-film RF amplifier using active bias and resistive feedback for temperature compensation and increased immunity to bias voltage variations. Low VSWR is maintained by inductive tuning while the RF is coupled through the amplifier by internal blocking capacitors. The 1054 Series amplifiers are available in either the TO-8 hermetic case or connected TC-1A package.

Pin Configuration UTO—TO-8T

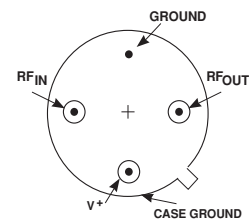

UTC—TC-1A

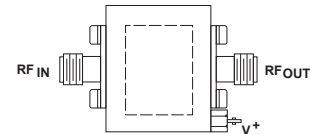

Schematic

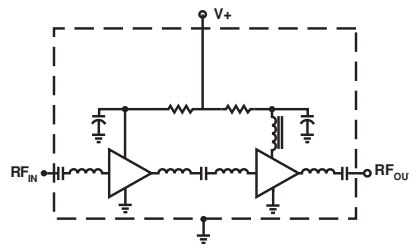

Maximum Ratings

Parameter	Maximum
DC Voltage	+10.0 Volts
Continuous RF Input Power	+13 dBm
Operating Case Temperature	-55 to +125°C
Storage Temperature	-62 to +150°C
“R” Series Burn-In Temperature	+125°C

Thermal Characteristics¹

θ_{JC}	105/75°C/W ²
Active Transistor Power Dissipation	48/109 mW ²
Junction Temperature Above Case Temperature	5/8°C ²
MTBF (MIL-HDBK-217E, A_{UF} @ 90°C)	575,700 Hrs.

Notes:

1. Values refer to first and second stages, respectively.

Weight: (typical) UTO—2.1 grams; UTC—21.5 grams

Electrical Specifications

(Measured in 50 Ω system @ +5 VDC nominal unless otherwise noted)

Symbol	Characteristic	Typical $T_C = 25^\circ\text{C}$	Guaranteed Specifications		Unit
			$T_C = 0 \text{ to } 50^\circ\text{C}$	$T_C = -55 \text{ to } +85^\circ\text{C}$	
BW	Frequency Range	5-1000	5-1000	5-1000	MHz
GP	Small Signal Gain (Min.)	24.0	23.5	23.0	dB
—	Gain Flatness (Max.)	± 0.3	± 0.7	± 0.7	dB
NF	Noise Figure (Max.)	3.5	4.0	4.5	dB
P_{1dB}	Power Output @ +1 dB Comp. (Min.)	+10.5	+9.5	+9.0	dBm
—	Input VSWR (Max.)	<1.5:1	2.0:1	2.0:1	—
—	Output VSWR (Max.)	<1.5:1	2.0:1	2.0:1	—
IP_3	Two Tone 3rd Order Intercept Point	+21.0	—	—	dBm
IP_2	Two Tone 2nd Order Intercept Point	+38.0	—	—	dBm
HP_2	One Tone 2nd Harmonic Intercept Point	+44.0	—	—	dBm
I_D	DC Current	40	—	—	mA

Typical Performance Over Temperature (@ +5 VDC unless otherwise noted)

Key: +25°C —
+85°C - -
-55°C —

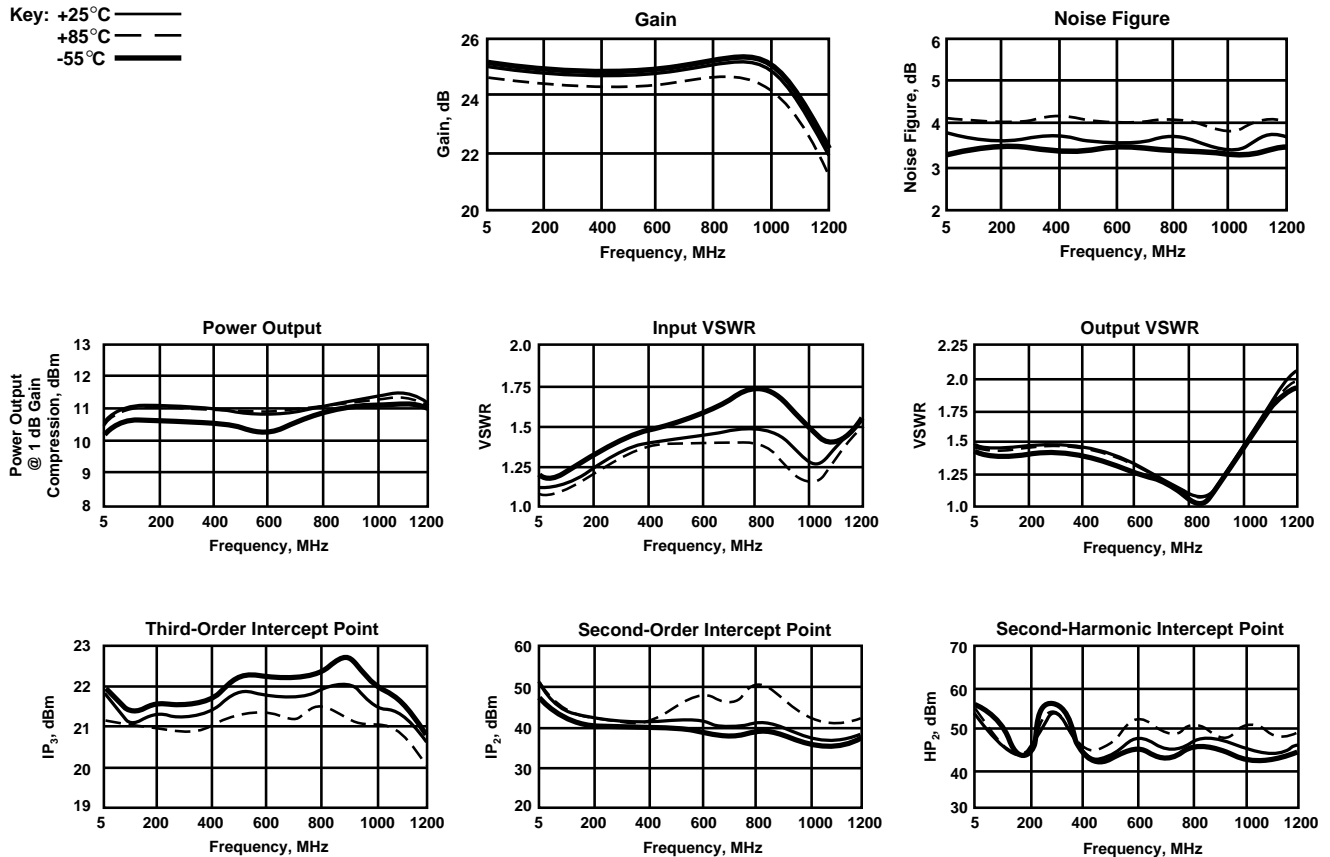

Automatic Network Analyzer Measurements (Typical production unit @ +25°C ambient)

Numerical Readings
Bias = 5.00 Volts

FREQ GHz	GPDEL ns	PHASE DEG	FREQ GHz	GPDEL ns	PHASE DEG
.050	.78	-2.18	.525	.73	2.76
.075	.78	-2.30	.550	.73	3.11
.100	.77	-2.37	.575	.73	3.46
.125	.77	-2.50	.600	.74	3.64
.150	.75	-2.40	.625	.75	3.79
.175	.74	-2.18	.650	.75	3.90
.200	.74	-1.91	.675	.76	3.91
.225	.74	-1.78	.700	.77	3.80
.250	.71	-1.31	.725	.79	3.56
.275	.72	-.90	.750	.80	3.20
.300	.73	-.65	.775	.82	2.71
.325	.72	-.29	.800	.83	2.05
.350	.73	.05	.825	.85	1.25
.375	.72	.40	.850	.87	.25
.400	.71	.82	.825	.80	-.86
.425	.70	1.32	.900	.92	-2.29
.450	.73	1.66	.925	.93	-3.88
.475	.72	2.05	.950	.06	-5.59
.500	.72	2.43	.975	.08	-7.47
			1.000	.96	9.28

Linearization Range: .05 to 1.00 GHz

S-Parameters
Bias = 5.00 Volts

FREQUENCY MHz	S ₁₁		S ₂₁		S ₁₂		S ₂₂	
	Mag	Ang	dB	Ang	dB	Ang	Mag	Ang
.005	.07	-178.1	24.6	20.5	-34.0	21.1	.21	166.95
.010	.05	-179.7	24.6	7.8	-34.0	9.8	.19	172.71
.020	.04	-175.4	24.6	.1	-33.9	3.6	.18	174.29
.030	.04	-171.7	24.6	-4.4	-33.9	1.0	.18	174.63
.040	.04	-167.7	24.6	-7.9	-33.9	-.8	.18	174.60
.050	.04	-164.4	24.6	-11.1	-33.9	-2.4	.18	174.50
.100	.06	-152.2	24.6	-25.4	-34.0	-7.5	.18	173.04
.150	.07	-148.8	24.5	-38.7	-34.0	11.4	.18	171.17
.200	.09	-150.3	24.5	-51.8	-34.0	-15.4	.18	168.66
.250	.11	-154.5	24.4	-64.8	-34.1	-19.7	.18	166.00
.300	.13	-159.8	24.4	-77.7	-34.1	-23.3	.19	162.32
.350	.14	-165.6	24.4	-90.6	-34.2	-27.4	.19	157.86
.400	.16	-172.5	24.4	-103.5	-34.2	-31.0	.18	152.91
.450	.16	-179.3	24.4	-116.5	-34.3	-34.5	.18	147.27
.500	.17	171.3	24.4	-129.6	-34.4	-38.6	.17	141.05
.550	.17	162.0	24.5	-142.8	-34.3	-42.6	.15	134.50
.600	.18	151.4	24.5	-156.3	-34.4	-46.5	.14	127.59
.650	.18	139.9	24.6	-169.9	-34.4	-50.5	.12	121.05
.700	.19	127.6	24.6	176.1	-34.4	-54.6	.10	115.30
.750	.19	114.9	24.7	161.8	-34.4	-59.5	.08	111.99
.800	.19	101.4	24.8	146.9	-34.6	-64.1	.05	116.92
.850	.19	86.8	24.8	131.4	-34.6	-69.3	.03	152.00
.900	.17	69.5	24.8	115.2	-34.8	-74.2	.06	-158.75
.950	.15	47.1	24.7	98.1	-35.1	-79.1	.11	-149.77
1.000	.12	15.1	24.4	80.4	-35.5	-83.9	.17	-153.20
1.100	.14	-63.7	23.3	44.8	-36.8	-91.3	.28	-168.85
1.200	.22	-105.7	21.5	11.6	-37.6	-91.7	.33	173.92
1.250	.24	-117.8	20.4	-3.5	-37.6	-89.5	.33	165.62
1.300	.25	-126.5	19.3	-17.9	-37.4	-89.8	.31	157.44
1.400	.23	-139.1	17.1	-44.8	-36.5	-92.0	.26	139.07
1.500	.17	-144.5	14.9	-70.1	-35.5	-102.1	.19	115.14
2.000	.26	-97.6	4.2	-175.1	-34.8	-159.0	.11	-83.31
3.000	.76	171.8	-16.4	45.9	-36.5	105.7	.41	136.14

Product Options

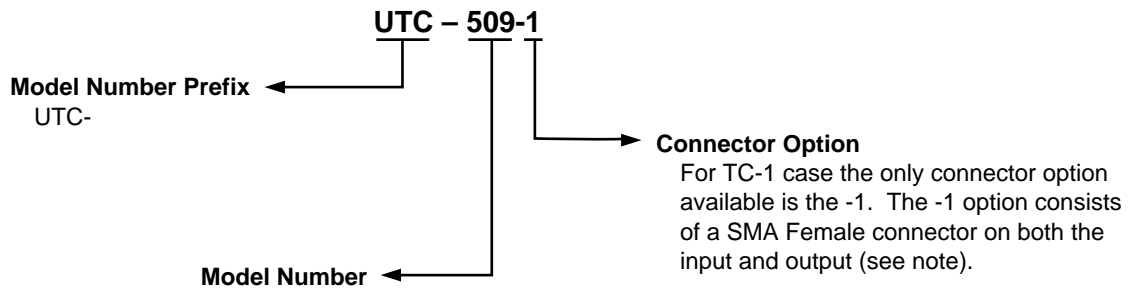
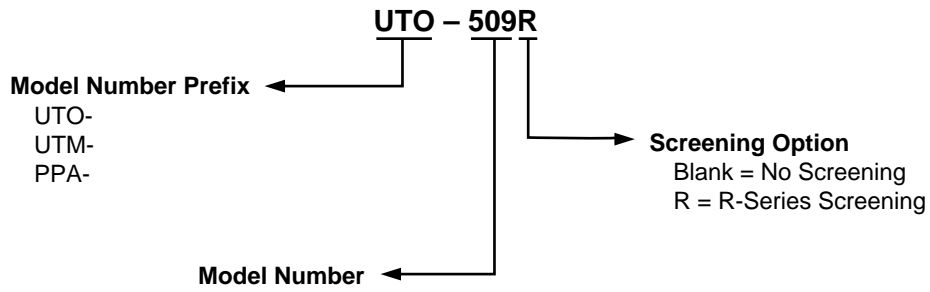

Note: R-Series screening is not available in the TC-1 case as the case is non-hermetic.

**Case Drawings
TO-8T**

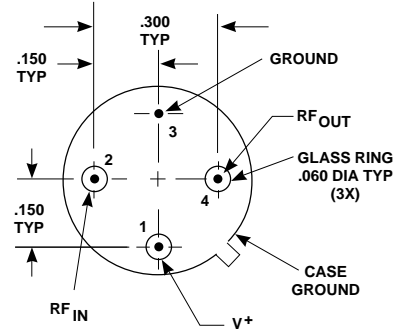
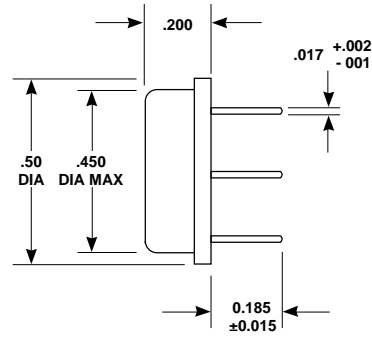
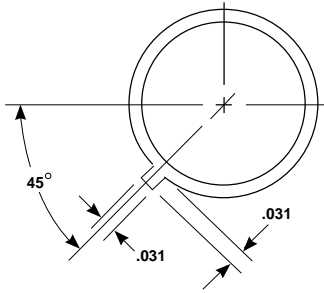

APPROXIMATE WEIGHT 2.1 GRAMS

- NOTES (UNLESS OTHERWISE SPECIFIED):**
 1. DIMENSIONS ARE SPECIFIED IN INCHES
 2. TOLERANCES: xx ± .02
 xxx ± .010

Case Drawings TC-1

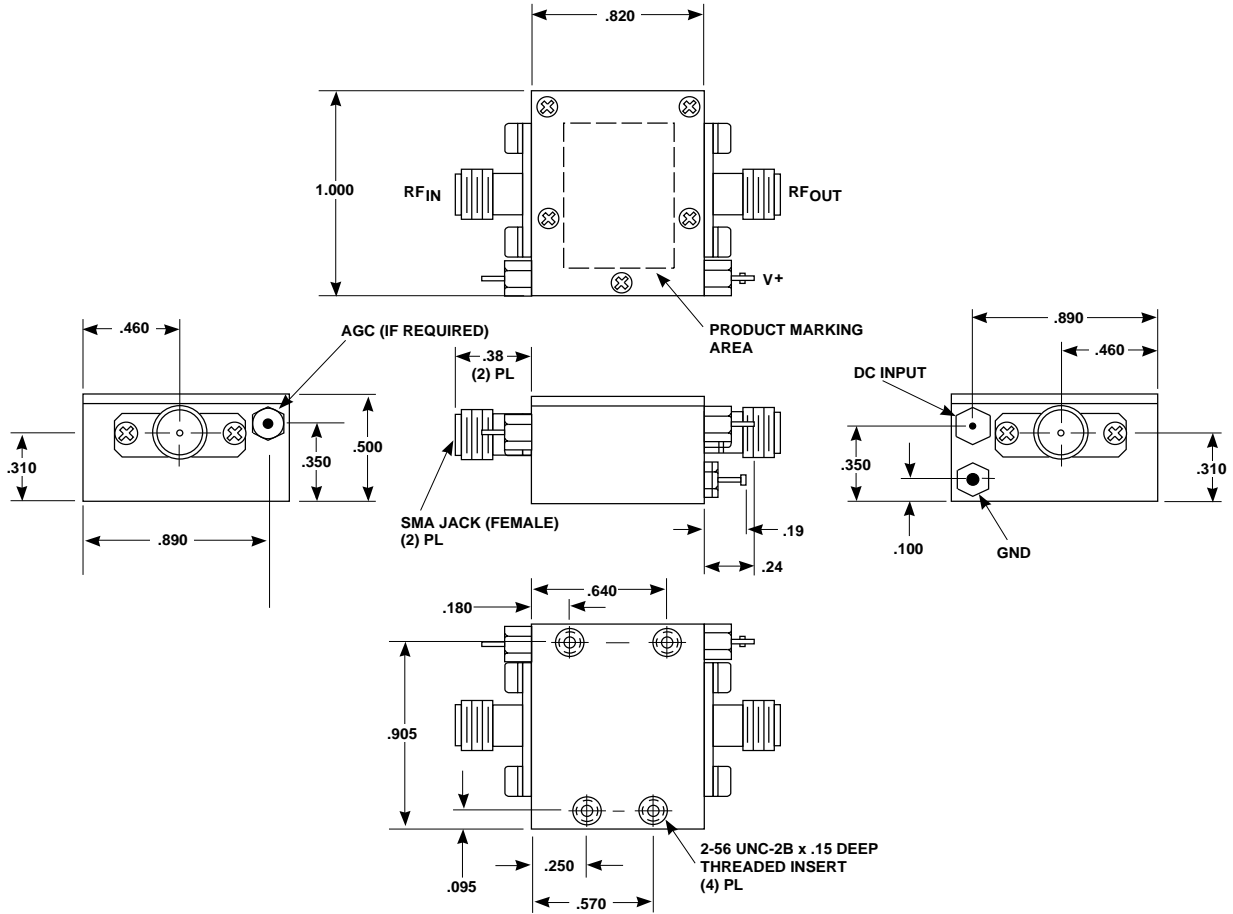

TYPICAL WEIGHT WITH CONNECTORS = 21.5 GRAMS

- NOTES: 1. THE TC-1 CASE IS A NON-HERMETIC CASE.
 2. THE ONLY CONNECTOR OPTION AVAILABLE FOR THE TC-1 CASE IS THE -1, SMA FEMALE CONNECTORS AT BOTH INPUT AND OUTPUT PORTS.

- NOTES (UNLESS OTHERWISE SPECIFIED):
 1. DIMENSIONS ARE SPECIFIED IN INCHES
 2. TOLERANCES: xx ± .02
 xxx ± .010

Contact Teledyne Microwave Solutions:
 650-691-9800
 650-962-6845 fax

Check for updates:
www.teledynemicrowave.com