



Hercules

G21.B.301111

Specification

Part No.	G21.B.301111
Product Name	Hercules G21 GSM Hercules Gen.II Penta Band Cellular Antenna Screw-mount (Permanent mount) GSM/GPRS/CDMA/EVDO/UMTS/HSPA/WCDMA 850/900/1800/1900/2100 MHz
Feature	<ul style="list-style-type: none"> • Low profile - Height 29mm and diameter 49mm • Heavy duty screw mount • UV and Vandal resistant PC housing • IP67 & IP69K – No ingress of dust and no water ingress permitted from powerful pressure jets in all directions and no performance degradation. Protected against close-range high pressure, high temperature spray downs. • Standard is 3M Cable RG174 SMA(M)-Customizable • Designed for a metal Ground Plane • ROHS Compliant

1. Introduction

The G21 (Generation II) Hercules is a high performance, steel thread-mount, Penta-band cellular antenna for external use on vehicles and outdoor assets worldwide. Omni-directional high gain across all bands ensures constant reception and transmission. The durable UV resistant PC housing is resistant to vandalism and direct attack.

With IP67 and IP69K waterproof rating, the G21 can be screw mounted on vehicles and outdoor/indoor assets via its extra thick thread. The antenna has a compact dimension at only 28.5mm in height and 49mm in diameter. The enclosure is designed to not catch on tree-branches.

Taoglas recommend a minimum cable length of 300mm when used on a ground plane to achieve an efficiency of greater than 30%.

This antenna can be mounted on metal structures. The G21 is an ideal solution for cellular external applications where it can operate with or without the ground plane.

2. Specification

ELECTRICAL CELLULAR - On 30x30cm Ground Plane						
Standard		AMPS	GSM	DCS	PCS	3G
Band (MHz)		850	900	1800	1900	2100
Frequency (MHz)		824-896	880-960	1710-1880	1850-1990	1920 -2170
Return Loss (dB)						
Cable Length (meter)	0.3	-6.0	-5.2	-6.1	-6.2	-5.8
	1.0	-7.8	-8.7	-11.4	-15.3	-13.7
	2.0	-8.1	-9.3	-16.5	-20.3	-19.5
	3.0	-11.0	-12.4	-17.5	-18.3	-18.1
	5.0	-11.8	-13.6	-17.6	-17.8	-17.8
Efficiency (%)						
Cable Length (meter)	0.3	51.1	41.4	38.0	46.5	33.3
	1.0	39.4	40.2	42.2	43.4	31.3
	2.0	24.3	27.5	28.4	28.2	29.6
	3.0	24.6	27.6	22.0	23.8	24.6
	5.0	17.1	16.4	15.7	15.0	12.0
Gain (dBi)						
Cable Length (meter)	0.3	2.0	1.5	4.0	4.3	4.2
	1.0	1.7	2.7	1.8	1.9	1.8
	2.0	1.4	2.1	0.8	-0.3	-0.7
	3.0	1.0	1.0	-0.9	-1.1	-1.1
	5.0	-0.8	-0.3	-4.2	-3.9	-4.2
Polarization				Linear		
Impedance				50 ohms		
Max Input Power				10 watts		
VSWR				<3.5:1		

2. Specification

ELECTRICAL CELLULAR - On 60x60cm Ground Plane						
Standard		AMPS	GSM	DCS	PCS	3G
Band (MHz)		850	900	1800	1900	2100
Frequency (MHz)		824-896	880-960	1710-1880	1850-1990	1920 -2170
Return Loss (dB)						
Cable Length (meter)	0.3	-6.0	-5.6	-8.8	-8.5	-7.8
	1.0	-7.8	-8.2	-13.6	-13.8	-16.3
	2.0	-8.9	-11.1	-16.7	-19.6	-19.5
	3.0	-11.0	-13.6	-17.8	-18.3	-18.6
	5.0	-12.3	-14.8	-19.1	-19.1	-18.2
Efficiency (%)						
Cable Length (meter)	0.3	31.0	30.3	47.1	43.6	41.6
	1.0	28.0	29.3	39.2	33.5	31.2
	2.0	26.3	28.5	28.8	29.6	30.7
	3.0	19.2	18.6	21.3	22.1	25.2
	5.0	11.4	12.8	13.7	11.6	12.3
Gain (dBi)						
Cable Length (meter)	0.3	2.1	2.3	3.1	3.0	2.8
	1.0	1.0	0.6	1.9	1.6	0.9
	2.0	0.6	0.2	0.8	-0.2	-0.8
	3.0	-0.5	0.1	0.2	-0.1	-1.1
	5.0	-2.3	-2.2	-2.9	-3.4	-3.9
Polarization		Linear				
Impedance		50 ohms				
Max Input Power		10 watts				
VSWR		<3.5:1				

2. Specification

ELECTRICAL CELLULAR - In Free Space						
Standard		AMPS	GSM	DCS	PCS	3G
Band (MHz)		850	900	1800	1900	2100
Frequency (MHz)		824-896	880-960	1710-1880	1850-1990	1920 -2170
Return Loss (dB)						
Cable Length (meter)	0.3	-6.2	-5.3	-5.8	-6.4	-5.6
	1.0	-8.1	-8.3	-10.9	-15.8	-13.2
	2.0	-8.5	-12.3	-15.8	-17.6	-17.2
	3.0	-11.6	-12.9	-16.9	-17.9	-18.3
	5.0	-11.8	-15.6	-18.6	-18.4	-18.8
Efficiency (%)						
Cable Length (meter)	0.3	53.2	51.3	42.8	43.6	46.7
	1.0	24.3	32.6	32.8	40.2	27.8
	2.0	24.1	25.8	27.8	31.2	26.2
	3.0	23.3	24.2	23.4	22.8	23.6
	5.0	13.6	20.8	12.1	11.8	10.3
Gain (dBi)						
Cable Length (meter)	0.3	0.4	0.9	2.4	2.5	2.2
	1.0	0.2	0.2	0.9	0.9	1.8
	2.0	-1.7	-1.3	1.1	-0.4	-1.5
	3.0	-1.8	-1.1	-1.2	-1.8	-1.9
	5.0	-3.3	-2.3	-4.1	-4.6	-4.7
Polarization				Linear		
Impedance				50 ohms		
Max Input Power				10 watts		
VSWR				<3.5:1		

2. Specification

MECHANICAL	
Dimensions	Height = 29 mm and Diameter = 49mm
Cable	3M RG174 – Fully Customizable
Connector	SMA-Male – Fully Customizable
Casing	UV Resistant PC
Base and Thread	Nickel plated steel
Thread Diameter	18 mm
Weather proof gasket	CR4305 foam with 3M9448B double-side adhesive
Sealant	Rubber Stopper
ENVIRONMENTAL	
Protection	IP67 & IP69K
Corrosion	5% NaCl for 96hrs - Nickel plated steel base and thread
Temperature Range	-40°C to +85°C
Thermal Shock	100 cycles -40°C to +85°C
Humidity	Non-condensing 65°C 95% RH
Shock (Drop Test)	1m drop on concrete 6 axes
Cable Pull	8 Kgf
Recommended Mounting Torque	24.5N·m
Maximum Mounting Torque	29.4N·m
Weight	150g

***Note:** Specifications may be subject to change

3. Test Set Up



Figure 1. G21 Antenna test set up in free space, 30x30 cm metal plate and 60x60 cm metal plate, R&SZVL6 VNA (Left) and R&S4100 CTIA 3D Chamber (Right).

4. Antenna Parameters

4.1 Return Loss

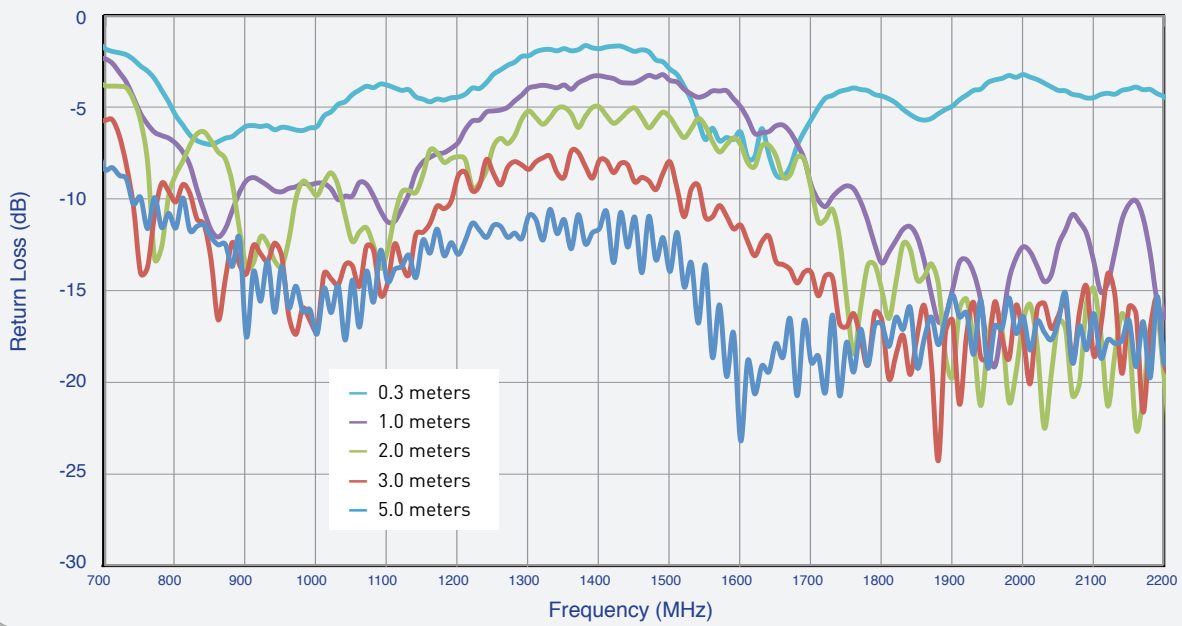

Figure 2. Return Loss of G21 Hercules antenna in free space.

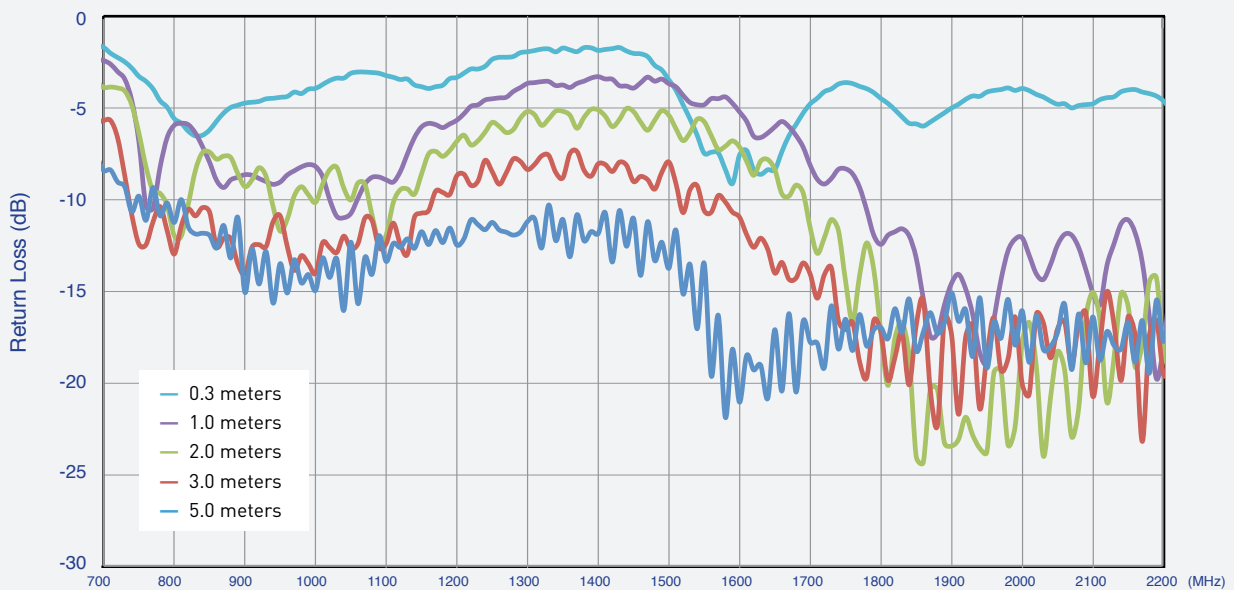

Figure 3. Return loss of G21 Hercules antenna on 30 cm metal plate.

4.1 Return Loss

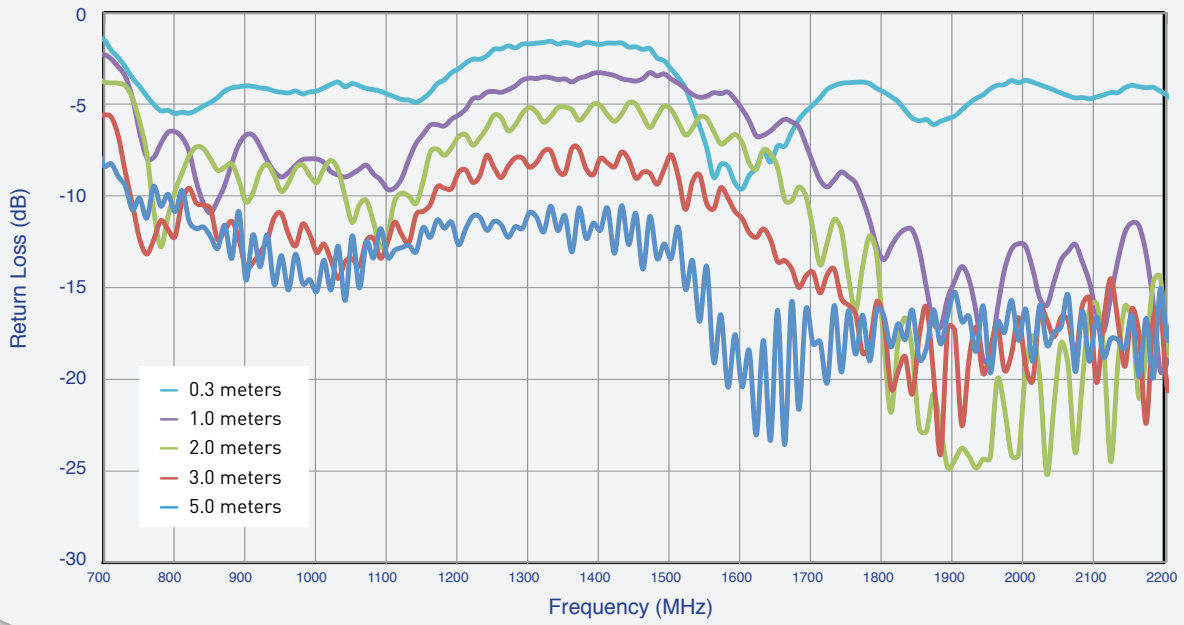

Figure 4. Return loss of G21 Hercules antenna on 60 cm metal plate.

4. Antenna Parameters

4.2 Efficiency

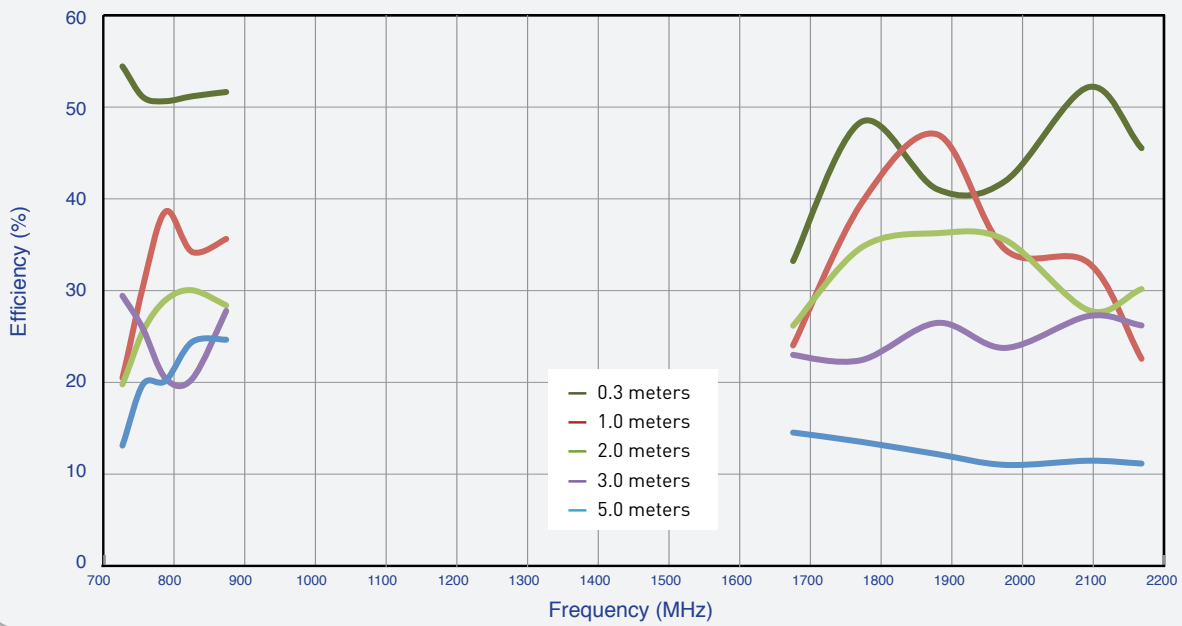

Figure 5. Efficiency of G21 Hercules antenna in free space.

4.2 Efficiency

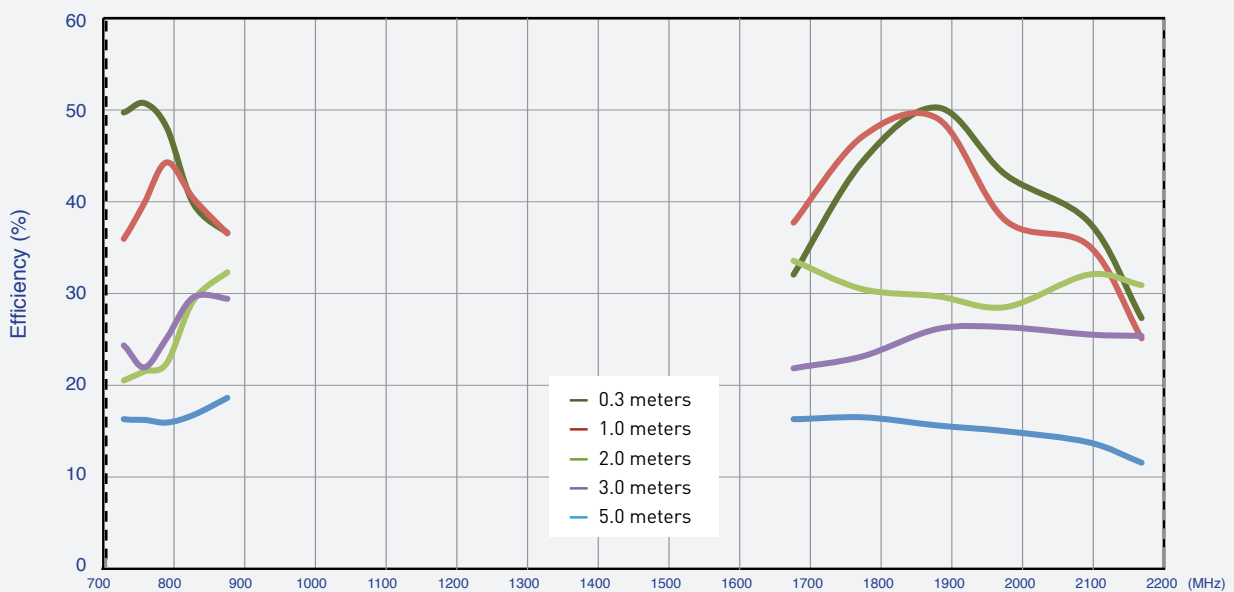

Figure 6. Efficiency of G21 Hercules antenna on 30 cm metal plate.

4.2 Efficiency

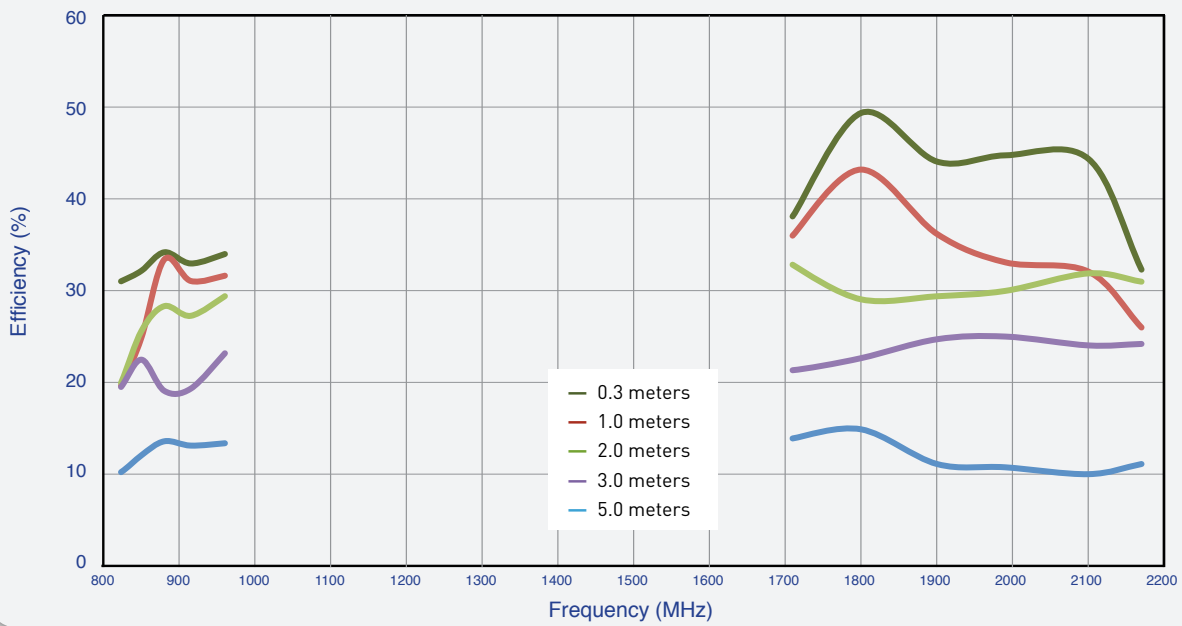

Figure 7. Efficiency of G21 Hercules antenna on 60 cm metal plate.

4.3 Peak Gain

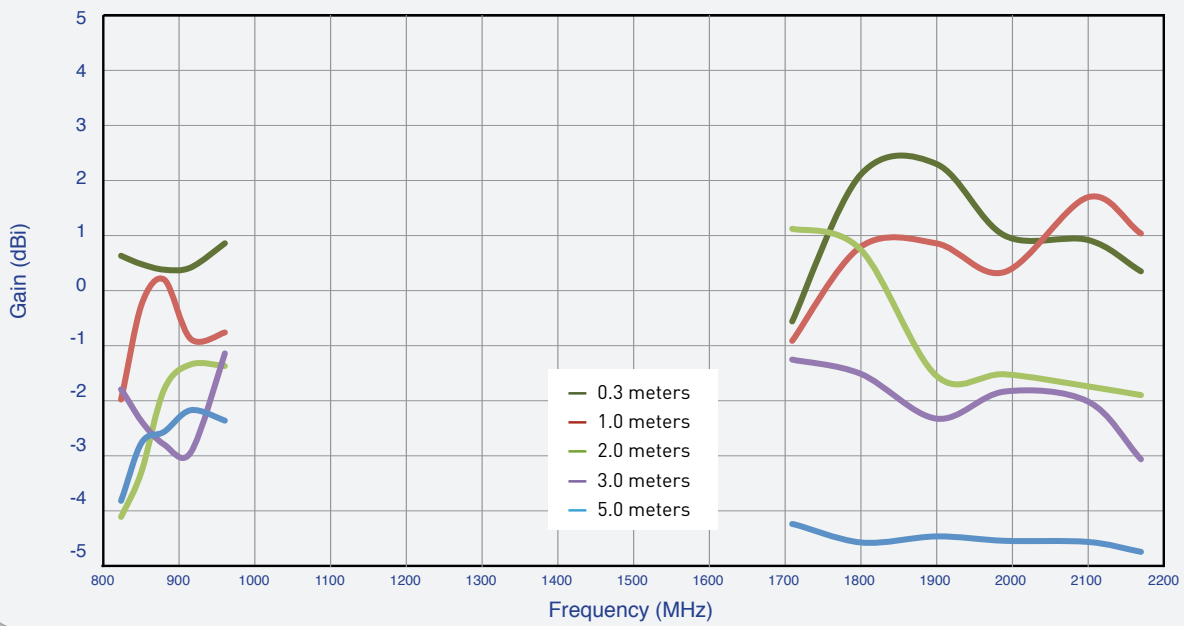

Figure 8. Peak Gain of G21 Hercules antenna in free space.

4.3 Peak Gain

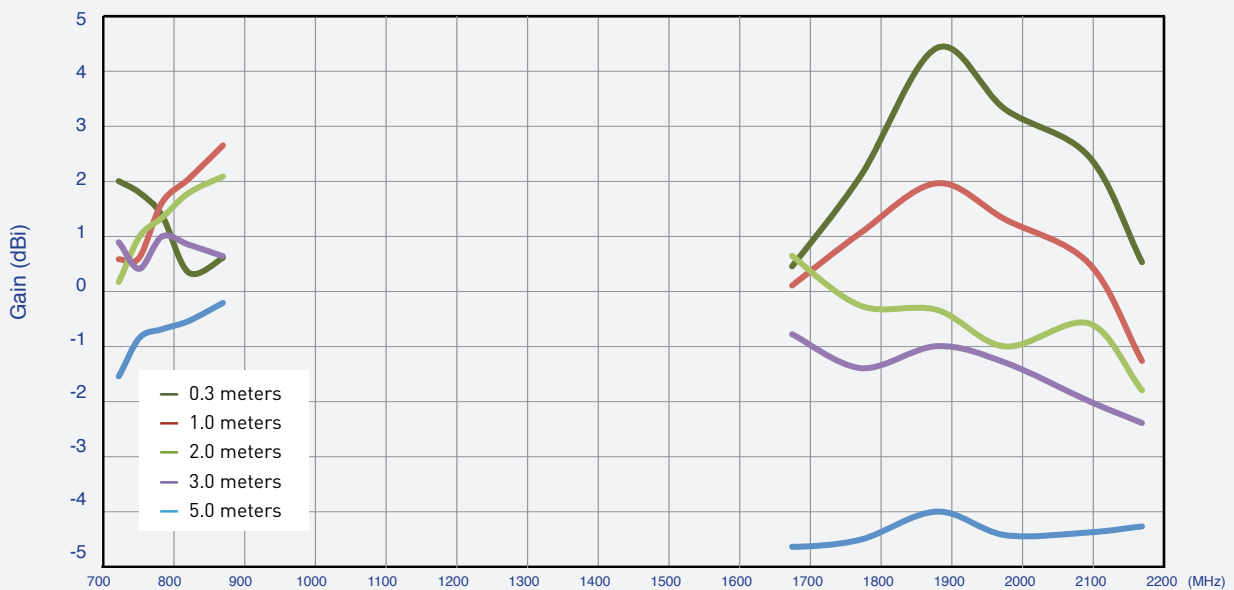

Figure 9. Peak Gain of G21 Hercules antenna on 30 cm metal plate.

4.3 Peak Gain

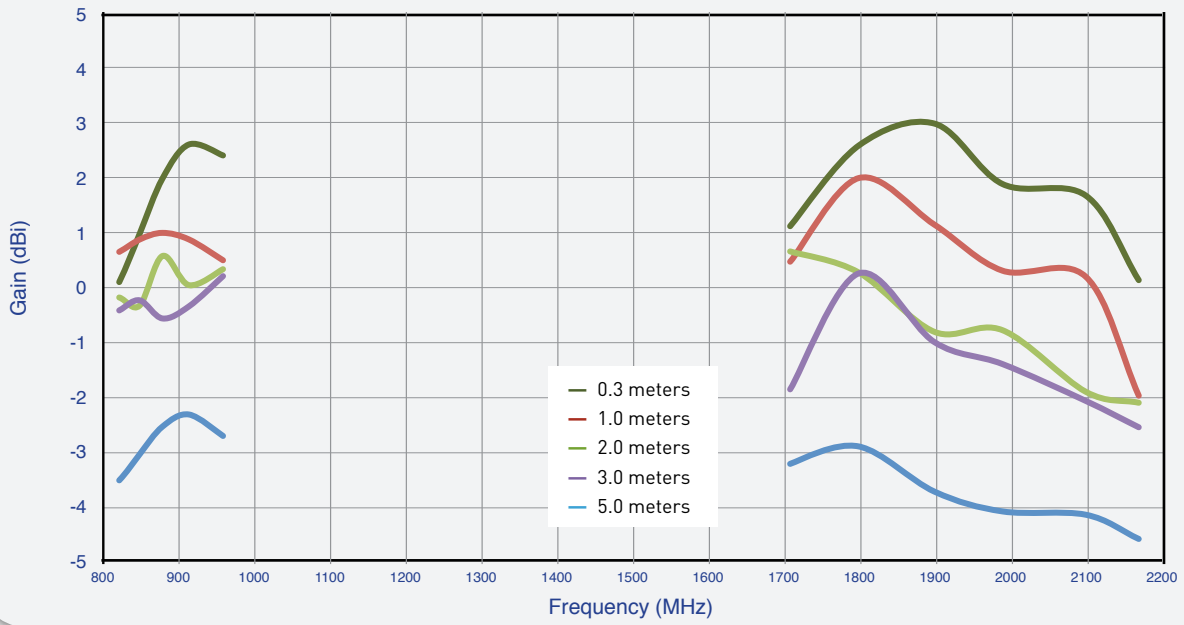

Figure 10. Peak Gain of G21 Hercules antenna on 60 cm metal plate.

5. Radiation Pattern

5.1 Radiation Patterns (Free Space)

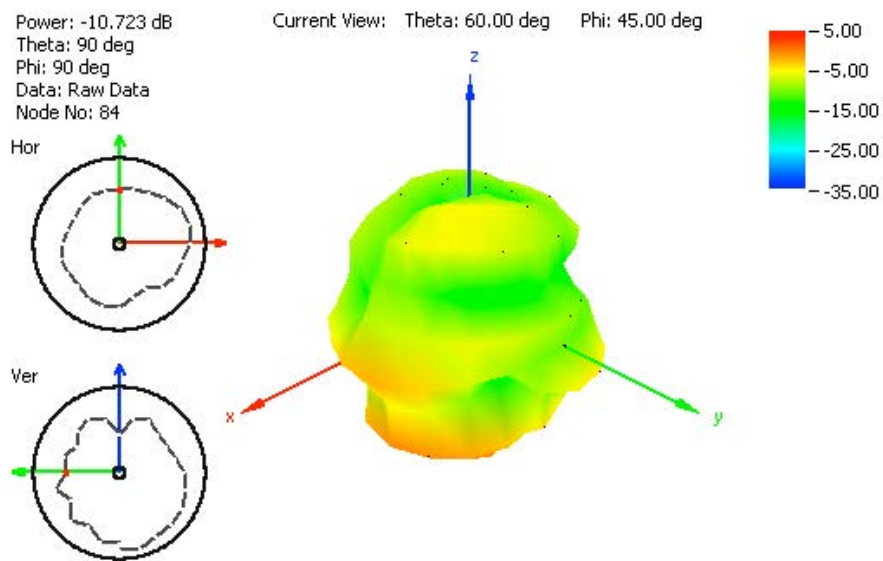

Figure 11. Radiation pattern at 849 MHz, Figure 1 as reference (dB), with 2 meter RG174 cable and free space

5.1 Radiation pattern

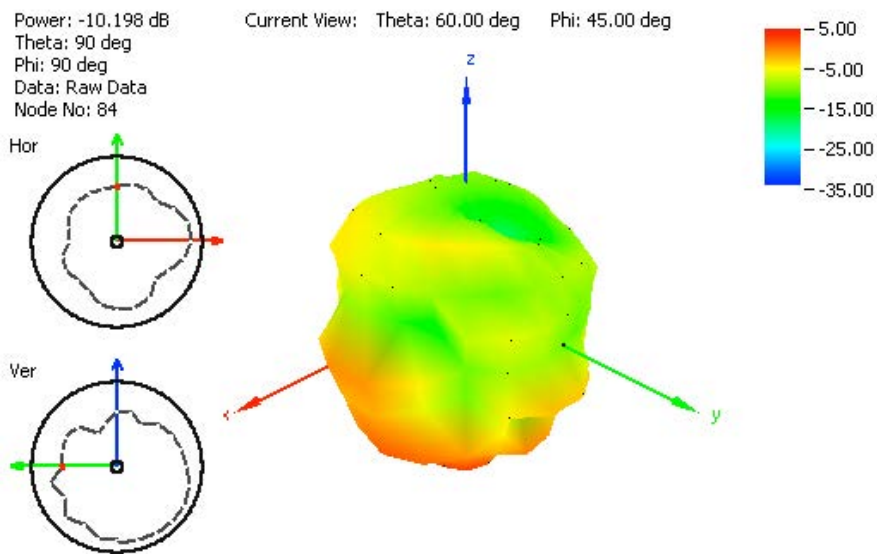

Figure 12. Radiation pattern at 915 MHz, Figure 1 as reference (dB), with 2 meter RG174 cable and free space

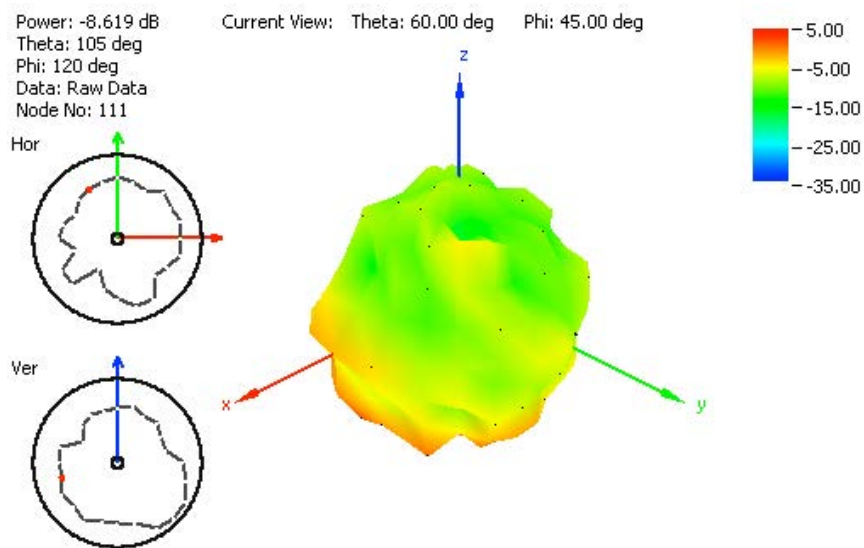

Figure 13. Radiation pattern at 1805 MHz, Figure 1 as reference (dB), with 2 meter RG174 cable and free space

5.1 Radiation pattern

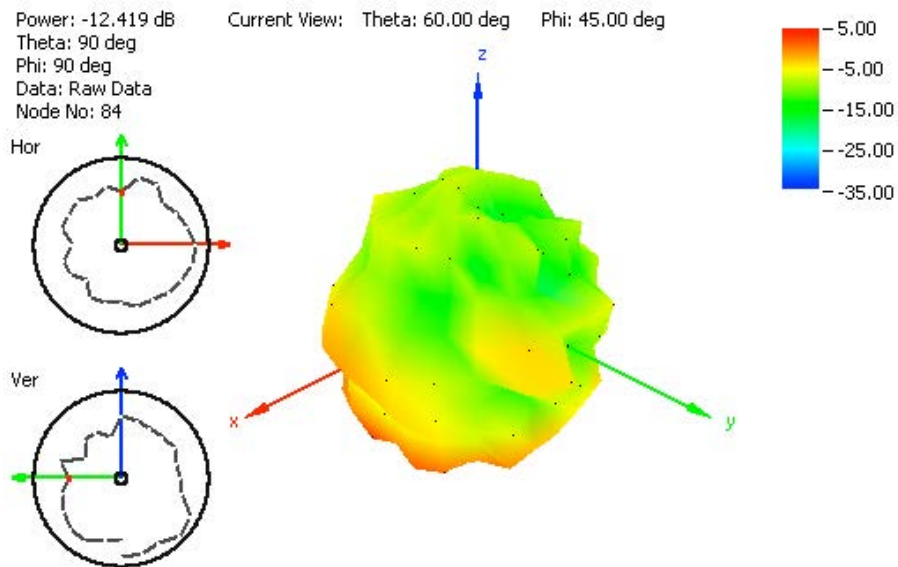

Figure 14. Radiation pattern at 1910 MHz, Figure 1 as reference (dB), with 2 meter RG174 cable and free space.

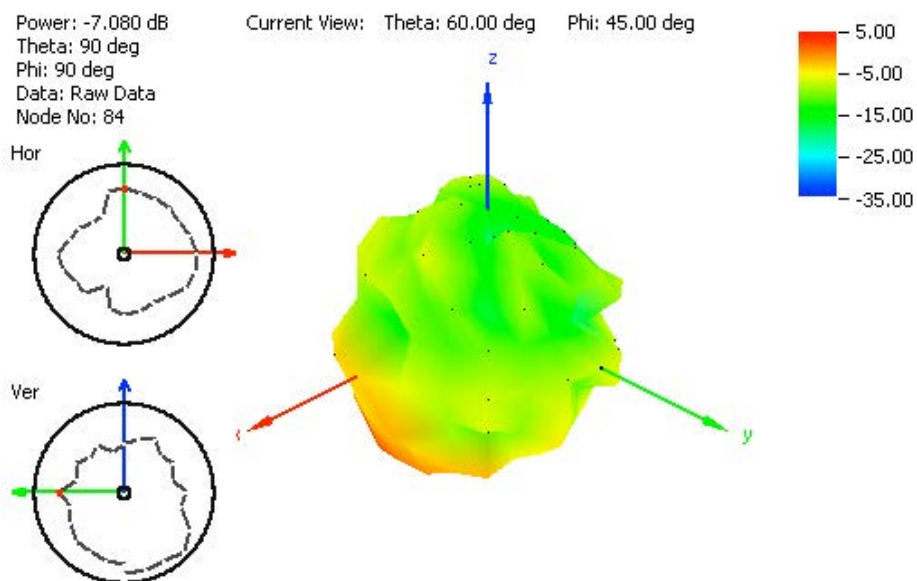

Figure 15. Radiation pattern at 2110 MHz, Figure 1 as reference (dB), with 2 meter RG174 cable and free space

5.2 Radiation Patterns (300*300mm Ground Plane)

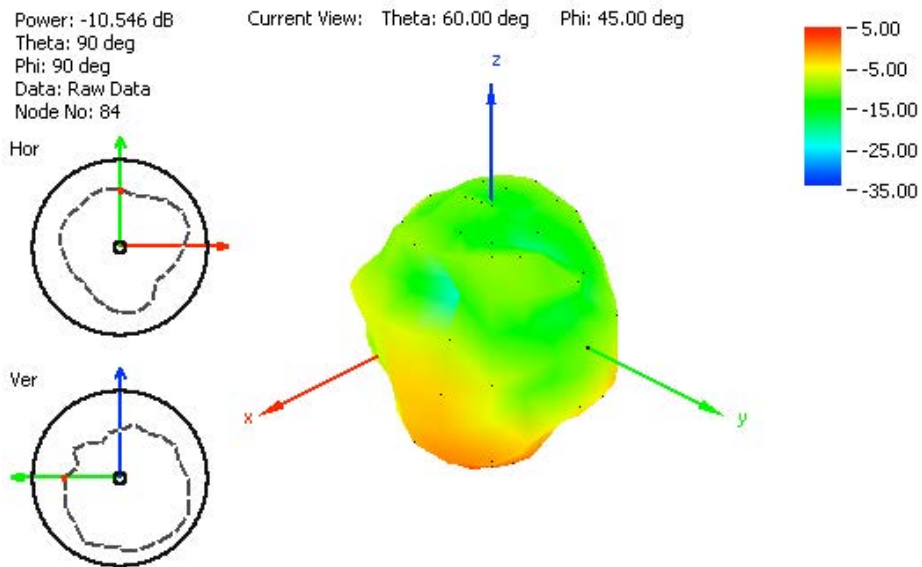

Figure 16. Radiation pattern at 849 MHz, Figure 1 as reference (dB), with 2 meter RG174 cable and 30x30 cm metal plate

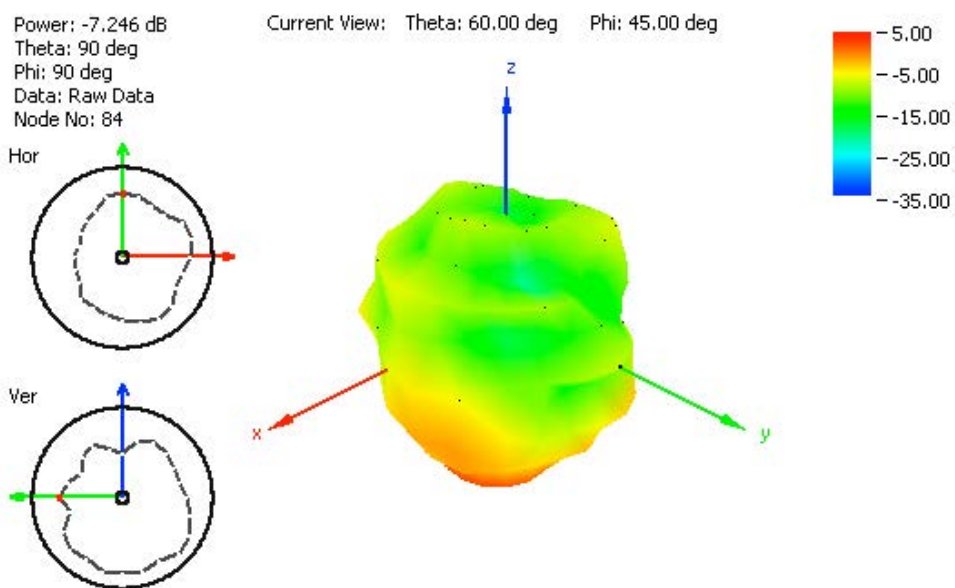

Figure 17. Radiation pattern at 915 MHz, Figure 1 as reference (dB), with 2 meter RG174 cable and 30x30 cm metal plate

5.2 Radiation Patterns (300*300mm Ground Plane)

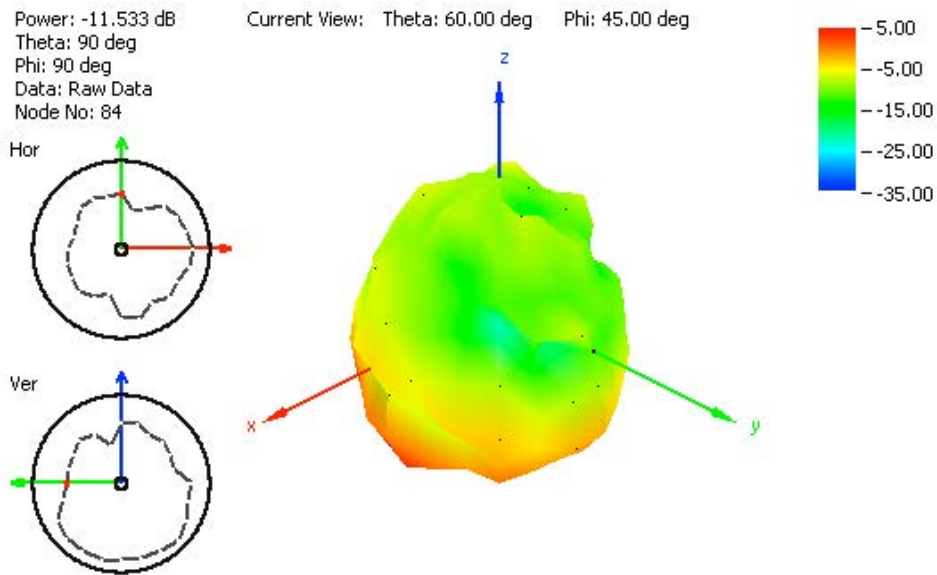

Figure 18. Radiation pattern at 1805 MHz, Figure 1 as reference (dB), with 2 meter RG174 cable and 30x30 cm metal plate

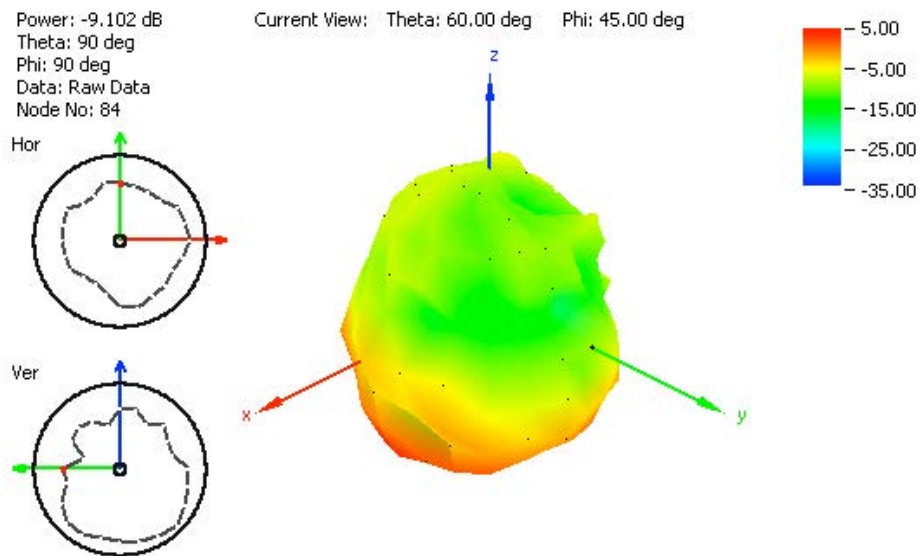

Figure 19. Radiation pattern at 1910 MHz, Figure 1 as reference (dB), with 2 meter RG174 cable and 30x30 cm metal plate

5.2 Radiation Patterns (300*300mm Ground Plane)

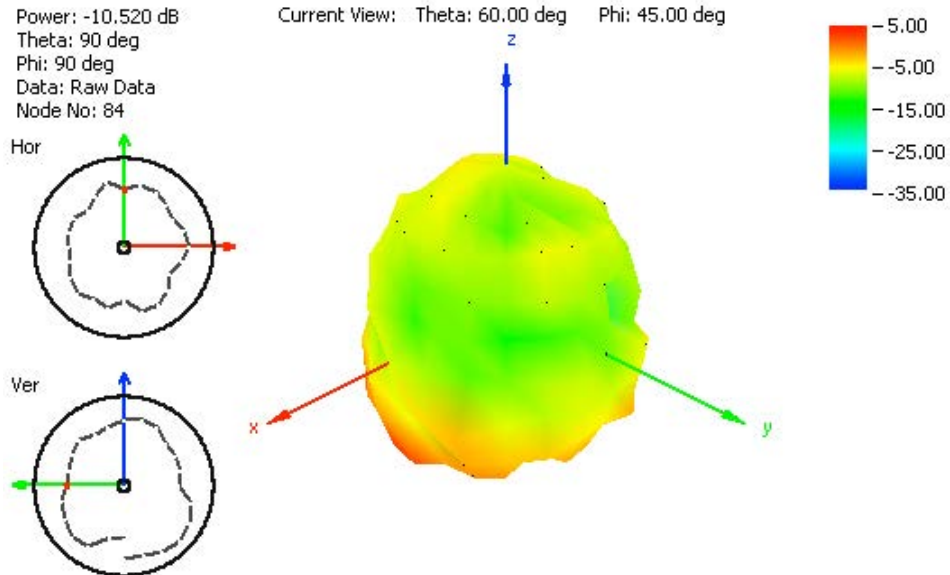

Figure 20. Radiation pattern at 2110 MHz, Figure 1 as reference (dB), with 2 meter RG174 cable and 30x30 cm metal plate.

5.3 Radiation Patterns (600*600mm Ground Plane)

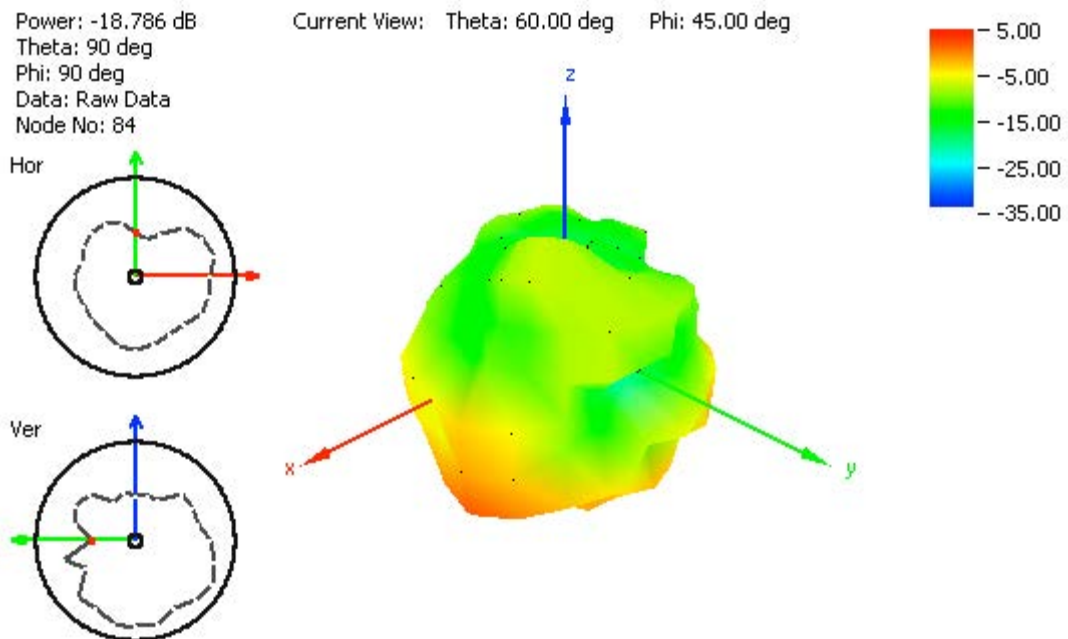

Figure 21. Radiation pattern at 849 MHz, Figure 1 as reference (dB), with 2 meter RG174 cable and 60x60 cm metal plate

5.3 Radiation Patterns (600*600mm Ground Plane)

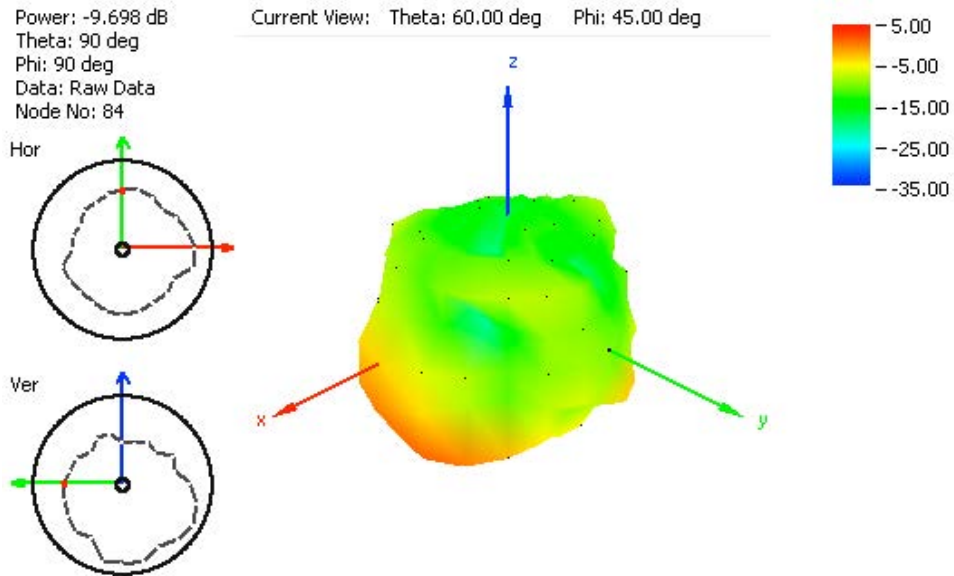

Figure 22. Radiation pattern at 915 MHz, Figure 1 as reference (dB), with 2 meter RG174 cable and 60x60 cm metal plate

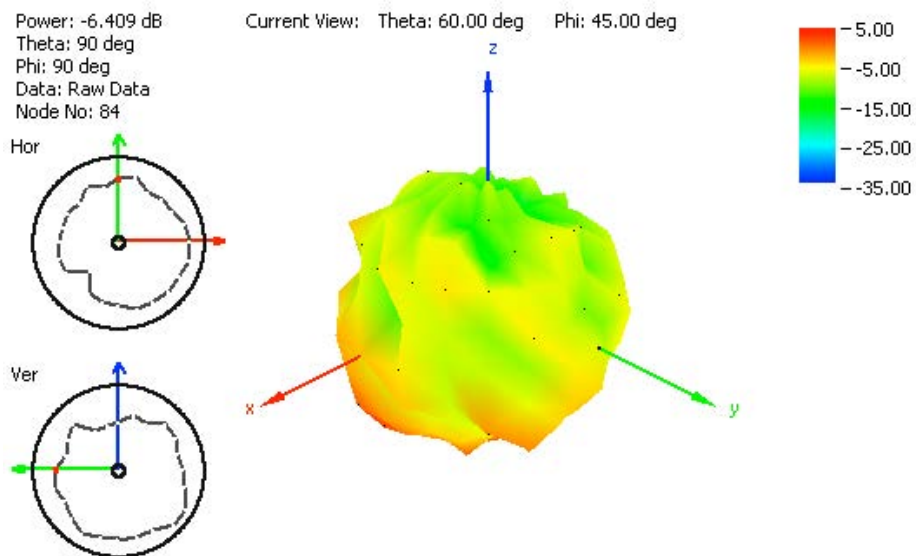

Figure 23. Radiation pattern at 1805 MHz, Figure 1 as reference (dB), with 2 meter RG174 cable and 60x60 cm metal plate

5.3 Radiation Patterns (600*600mm Ground Plane)

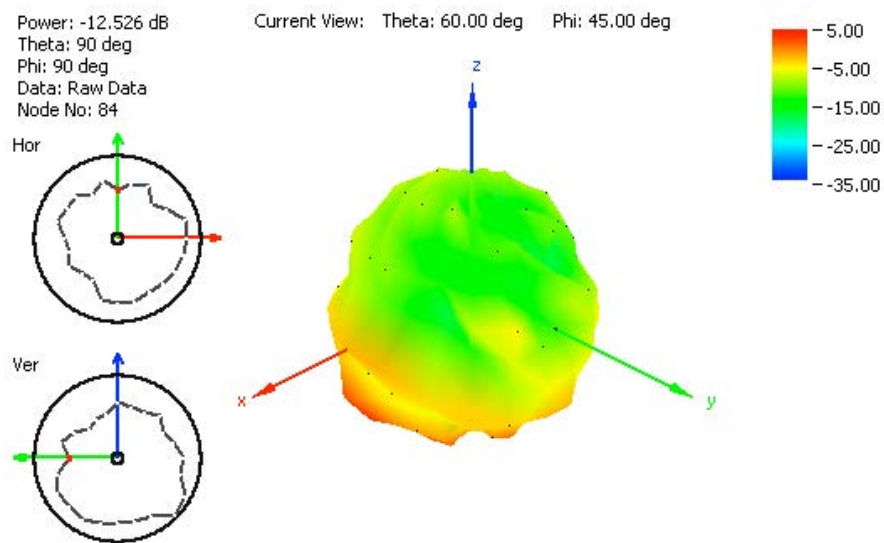

Figure 24. Radiation pattern at 1910 MHz, Figure 1 as reference (dB), with 2 meter RG174 cable and 60x60 cm metal plate.

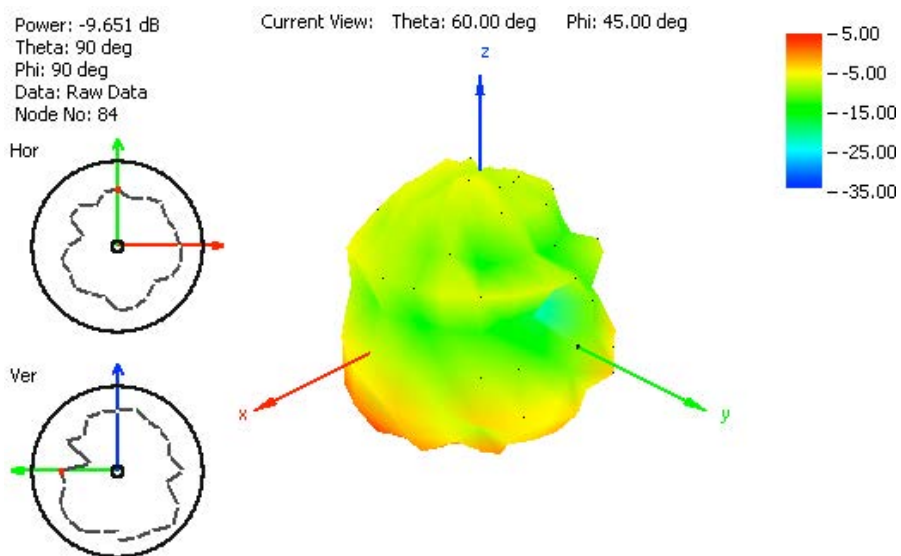
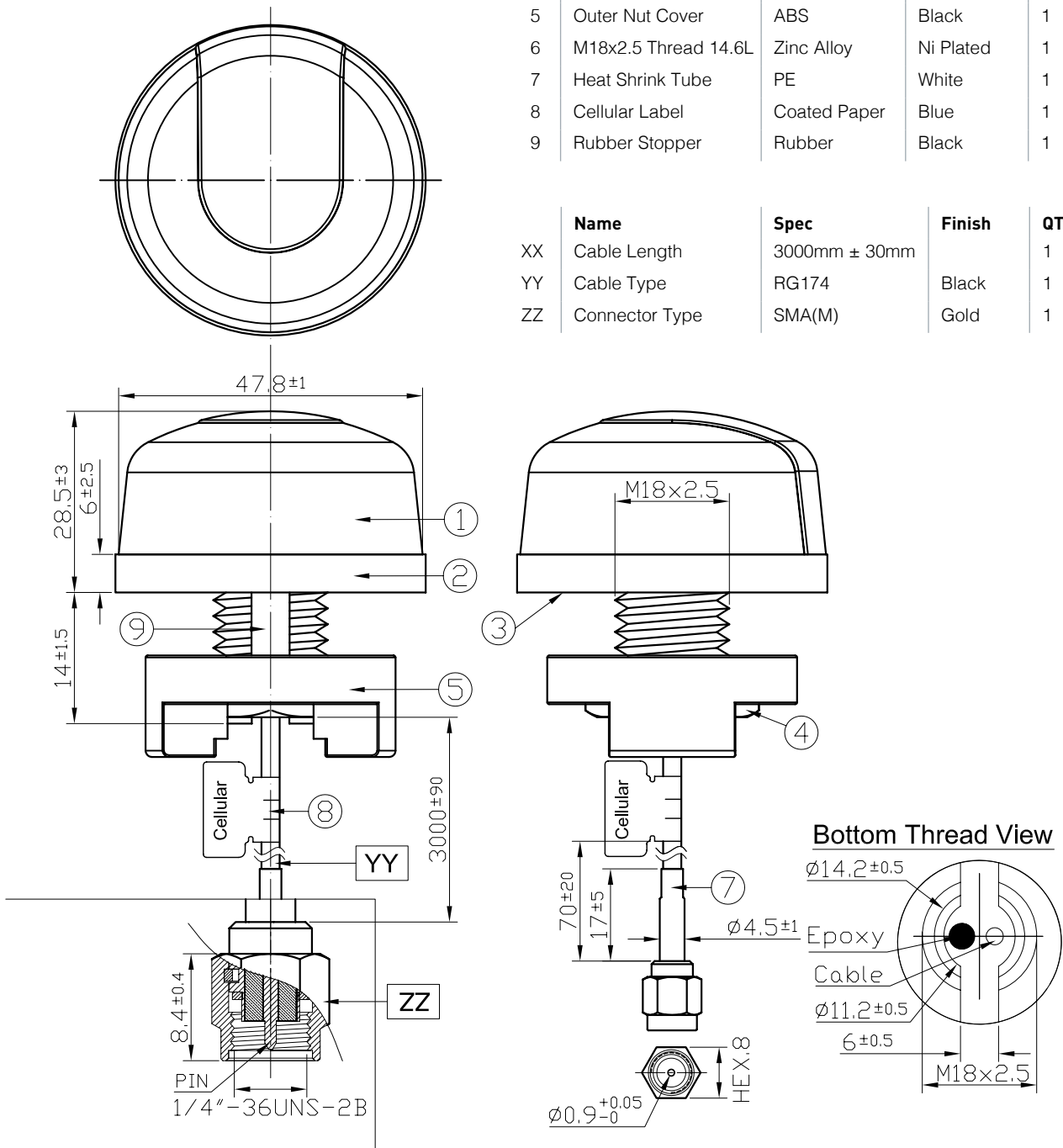

Figure 25. Radiation pattern at 2110 MHz, Figure 1 as reference (dB), with 2 meter RG174 cable and 60x60 cm metal plate.

6. Mechanical Drawings

	Name	Material	Finish	QTY
1	Housing	PC	Black	1
2	Closed Cell Foam	DP-3060W	Black	1
3	3M Double Adhesive	3M 9448 HK	White Liner	1
4	M18 Inner Nut	Steel Carbon	Ni Plated	1
5	Outer Nut Cover	ABS	Black	1
6	M18x2.5 Thread 14.6L	Zinc Alloy	Ni Plated	1
7	Heat Shrink Tube	PE	White	1
8	Cellular Label	Coated Paper	Blue	1
9	Rubber Stopper	Rubber	Black	1

	Name	Spec	Finish	QTY
XX	Cable Length	3000mm ± 30mm		1
YY	Cable Type	RG174	Black	1
ZZ	Connector Type	SMA(M)	Gold	1



7. Installation

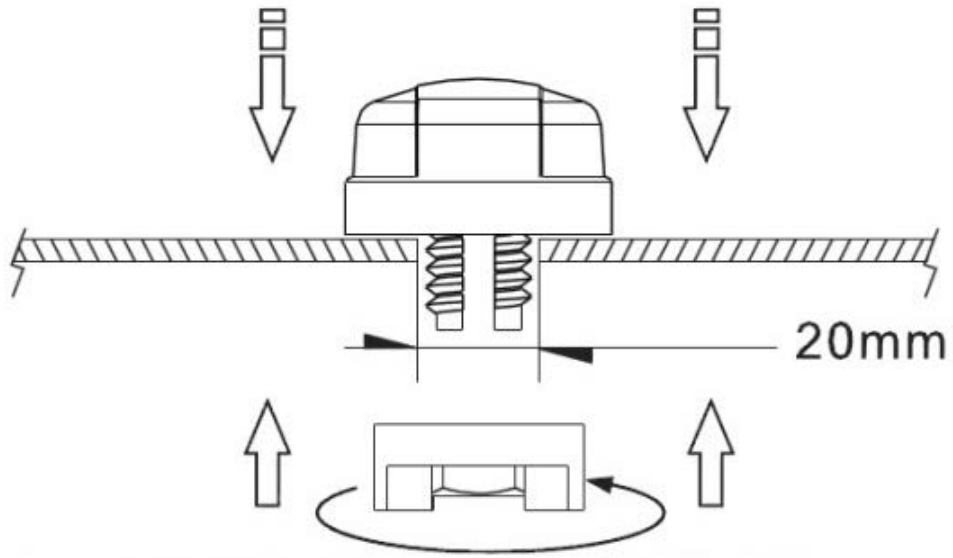

Recommended torque for mounting is 24.5N·m
Maximum torque for mounting is 29.4N·m



8. Packaging

1 G21.B.301111 per PE bag
Bag Dimensions - 300*100mm
Total Weight - 150g

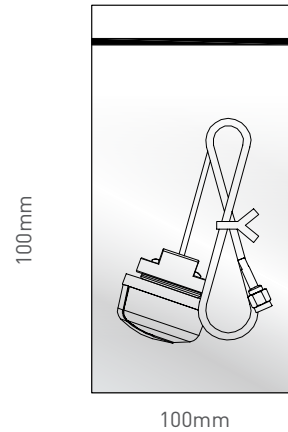

60 PE bags per carton
Carton Dimensions - 320*300*260mm
Weight - 9.6Kg

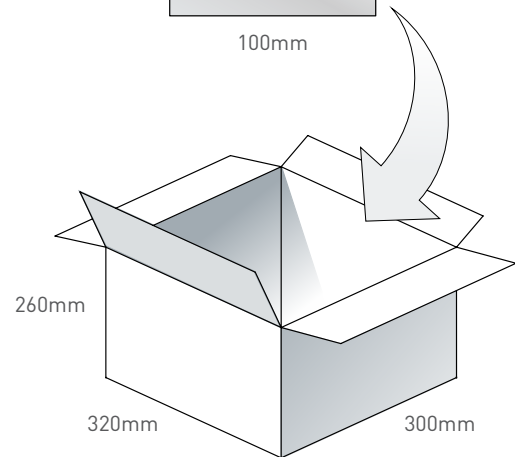

Pallet Dimensions 1200*1200*1500mm
60 Cartons per pallet
12 Cartons per layer
5 Layers

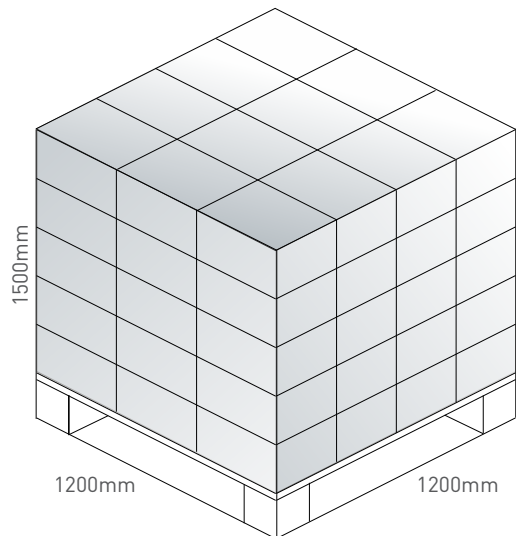

Taoglas makes no warranties based on the accuracy or completeness of the contents of this document and reserves the right to make changes to specifications and

product descriptions at any time without notice. Taoglas reserves all rights to this document and the information contained herein.

Reproduction, use or disclosure to third parties without express permission is strictly prohibited.
Copyright © Taoglas Ltd.