

Heat transfer, cold side:	D	Direct
Heat transfer, warm side:	L	Liquid
Cascade:	-	
Cooling power: [W]	060	Calculated 65 W at dT=0°C. Tolerance ±10%.
Voltage, nominal: [VDC]	12	12 VDC (15 VDC Max.)
TEM current (A):		Nominal: 4.7 A, Initial: 5.2 A. All at dT=0°C. Tolerance: ±10%.
TE-Module(s) connections:		Max. temp. 80°C.
Fan(s), cold side:	0	-
Fan(s), warm side:	0	-
Temperature controller, sensor:	0	-
Temperature control settings:	0	-
Trimtable:		-
Accuracy & Hysteresis:		-
Temperature control position:	0	-
Options: Voltage protection:	0	-
Rapid Cooling / Economy:		-
Overheating thermostat:		75°C ±5°C on hot side heat sink surface. Not wired in series with TEMs. Use it to control a relay.
Max. operating temperature:		63°C
Enclosed:		Turbulators fitted in liquid channels. 2x L-PNIPP-6-1/8
Packing:		Individual cardboard box.

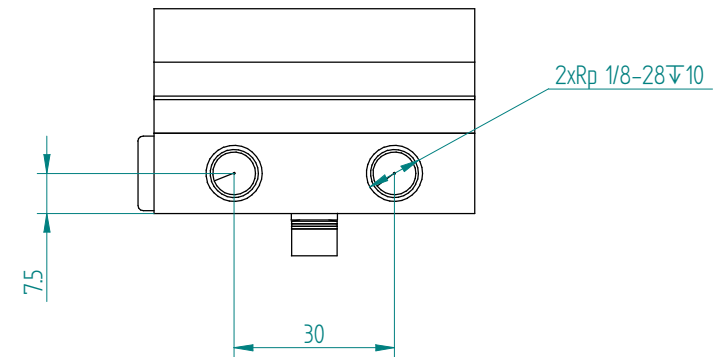

For overheating protection the cooler is equipped with a bimetal thermostat. The maximum rating for the thermostat is 8 A DC. For systems with 8 A or less the thermostat can be connected directly in series with the ThermoElectric Modules (TEM:S). Otherwise connect the TEM:S to the power source through a relay of suitable rating which state is controlled with the bimetal thermostat.

Note:
Cooled liquid block needs to be isolated from air humidity to minimize risk for condensation and thermally insulated for best performance.

General tolerances: SS-ISO 2768-1 v	First angle projection:	Dimension units: Metric: [mm]
--	-------------------------	----------------------------------

Comment / Deviations: Heat sinks and, if applicable, D-plates and shrouds in anodised aluminium. Hi-Pot tested 750VDC					
Designed by: M. Nyman	Checked by: A. Thorén	Approved by: C. Johansson	Release date: 2011-07-06	Project: Standard	Customer:
Laird Technologies S-43153 Molndal, Sweden tfn: +46 31 420530, fax: +46 31 247909 e-mail: info@lairdtech.com Web: www.lairdtech.com			Title: TE ASSEMBLY 12 VDC DIRECT - LIQUID		
Part nr: DL-060-12-00-00-00			Rev. 06	Version: -	Scale: 1:1 Size, sheet: A3, 1/4

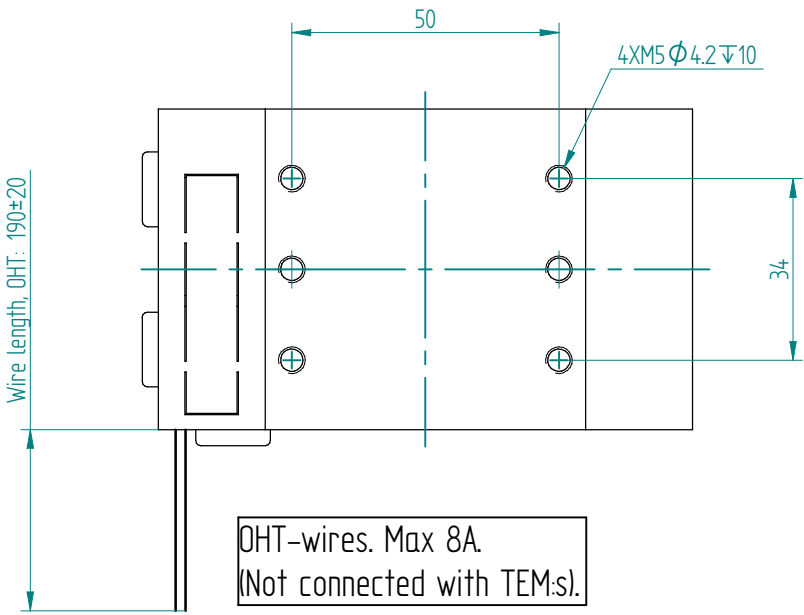

OHT-wires. Max 8A.
(Not connected with TEM:s).

Typical Pressure - Flow behavior of liquid block assembly.
(for more information contact Laird Technologies customer service)

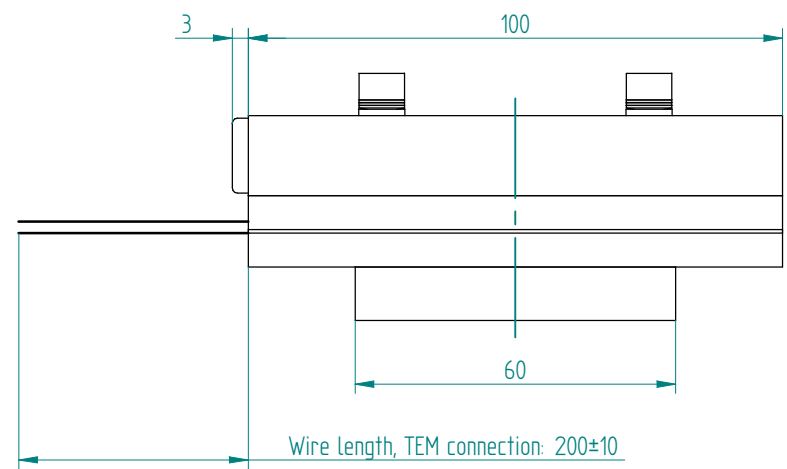
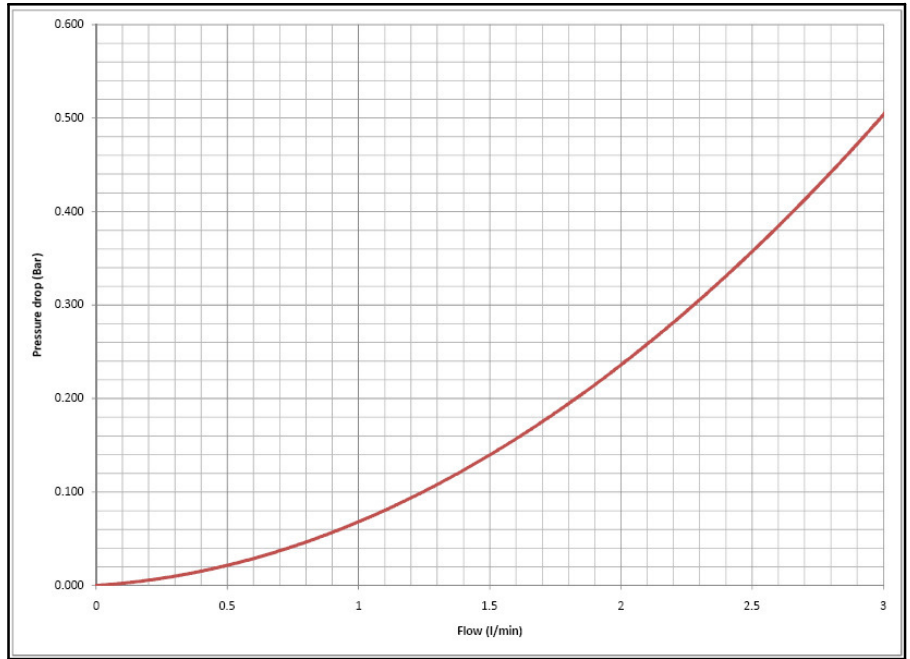

Wire length, TEM connection: 200±10

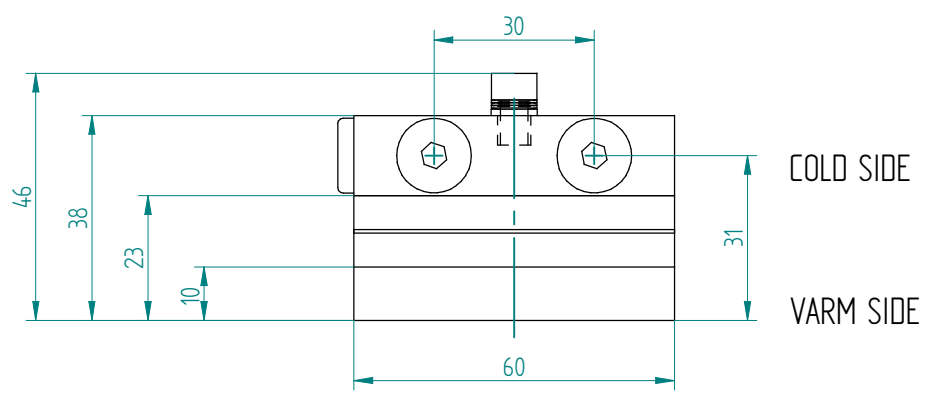

COLD SIDE
WARM SIDE

Electrical connections:
Red: + TEM
Black: - TEM
AWG: 20

D-Plate tolerances:

Flatness: $\square 0.1/100$
Roughness: $\sqrt{3.2}$

General tolerances: SS-ISO 2768-1 v
First angle projection: \triangle
Dimension units: Metric: [mm]

Comment / Deviations: Heat sinks and, if applicable, D-plates and shrouds in anodised aluminium. Hi-Pot tested 750VDC					
Designed by: M. Nyman	Checked by: A. Thorén	Approved by: C. Johansson	Release date: 2011-07-06	Project: Standard	Customer:
Laird Technologies S-43153 Molndal, Sweden tfn +46 31 420530, fax +46 31 247909 e-mail: info@lairdtech.com Web: www.lairdtech.com			Title: TE ASSEMBLY 12 VDC DIRECT - LIQUID		
Part nr: DL-060-12-00-00-00			Rev: 06	Version: -	Scale: Size, sheet 1:1 A3, 2(4)