

GENERAL DESCRIPTION

The DS25LV02 provides data storage and serial number identification for battery packs. The low-voltage Dallas 1-Wire® interface enables serial communication on a single battery contact and the 64-bit unique serial number allows multidrop networking and identification of individual devices. The 1024-bit EPROM memory is organized as 4 pages of 32 bytes each and supports storage of battery cell characteristics, charging voltage, current and temperature parameters, as well as battery pack manufacturing data. CRC verification provides data integrity during communication. The EPROM pages are in-circuit writable and can be individually locked to protect data. The DS25LV02 is designed to be completely backward-compatible with the DS2502 for existing designs.

APPLICATIONS

- Cell Phones/Smartphones
- Digital Cameras
- MP3 Players

TYPICAL APPLICATION CIRCUIT

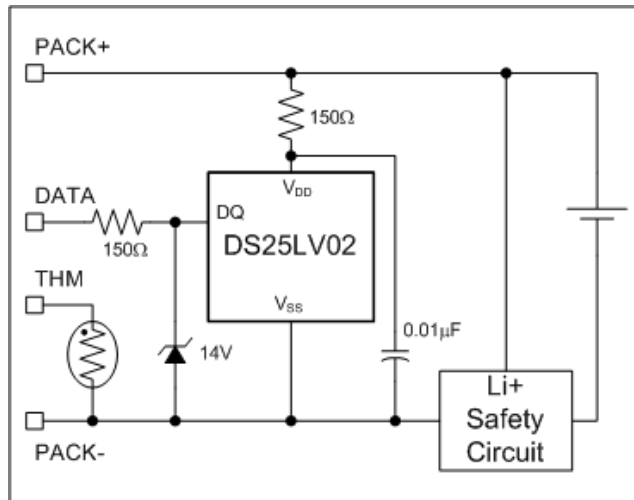

FEATURES

- 128 Bytes of EPROM Storage Organized into Four Separately Lockable Pages
- Backward-Compatible with DS2502
- Dallas 1-Wire Interface
- Input Logic Thresholds Compatible with 1.8V I/O Supply Rail
- Unique 64-Bit Serial Number
- Operates with V_{DD} as Low as 2.2V
- Tiny, Thin SOT-23 Package

PIN CONFIGURATION

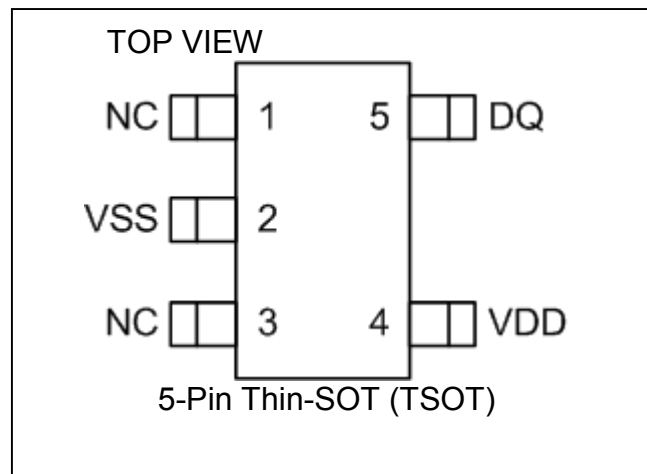

ORDERING INFORMATION

PART	TEMP RANGE	PIN-PACKAGE
DS25LV02R+U	-30°C to +85°C	5 Thin SOT
DS25LV02R+T&R	-30°C to +85°C	5 Thin SOT in Tape-and-Reel

+Denotes lead-free package.

1-Wire is a registered trademark of Dallas Semiconductor.

Certain commands, modes, and registers are capitalized for clarity.

ABSOLUTE MAXIMUM RATINGS

Voltage Range on DQ, Relative to V_{SS}	-0.3V to +12V
Voltage Range on V_{DD} , Relative to V_{SS}	-0.3V to +6V
Operating Temperature Range	-30°C to +85°C
Storage Temperature Range	-55°C to +125°C
Soldering Temperature	See IPC/JEDEC J-STD-020A Specification

Stresses beyond those listed under "Absolute Maximum Ratings" may cause permanent damage to the device. These are stress ratings only, and functional operation of the device at these or any other conditions beyond those indicated in the operational sections of the specifications is not implied. Exposure to the absolute maximum rating conditions for extended periods may affect device.

RECOMMENDED DC OPERATING CONDITIONS

($2.2V \leq V_{DD} \leq 5.5V$, $T_A = -30^\circ\text{C}$ to $+85^\circ\text{C}$.)

PARAMETER	SYMBOL	CONDITIONS	MIN	TYP	MAX	UNITS
Supply Voltage	V_{DD}	(Notes 1, 2)	2.2		5.5	V
Data Pin Communication Voltage	V_{DQ}	(Note 1)	-0.3		+5.5	V
Data Pin Programming Voltage	V_{PP}	(Notes 1, 2, 5)	11.5		12.0	V

DC ELECTRICAL CHARACTERISTICS

($2.2V \leq V_{DD} \leq 5.5V$, $T_A = -30^\circ\text{C}$ to $+85^\circ\text{C}$.)

PARAMETER	SYMBOL	CONDITIONS	MIN	TYP	MAX	UNITS
Supply Current	I_{DD0}	DQ Idle (Note 4)		0.8	2	μA
	I_{DD1}	Communication mode, DQ active			300	
Input-Logic High: DQ	V_{IH}	(Note 1)	1.5			V
Input-Logic Low: DQ (Note 1)	V_{IL}	$V_{DD} \geq 2.5V$			0.6	V
					0.4	
Output-Logic Low: DQ	V_{OL}	$I_{OL} = 4\text{mA}$ (Note 1)			0.4	V
Pulldown Current: DQ	I_{PD}			0.5		μA

EPROM RELIABILITY SPECIFICATION

($2.2V \leq V_{DD} \leq 5.5V$, $T_A = -30^\circ\text{C}$ to $+85^\circ\text{C}$.)

PARAMETER	SYMBOL	CONDITIONS	MIN	TYP	MAX	UNITS
Storage	t_{EES}	(Notes 2, 3)	10			Years

AC ELECTRICAL CHARACTERISTICS: EPROM PROGRAMMING(3.0V ≤ V_{DD} ≤ 5.5V, T_A = -30°C to +50°C.)

PARAMETER	SYMBOL	CONDITIONS	MIN	TYP	MAX	UNITS
Programming Pulse Width	t _{PP}	(Notes 1, 2, 5, 6)	480		5000	μs
Program Voltage Rise Time	t _{RP}	(Notes 1, 2, 5)	0.5		5.0	μs
Program Voltage Fall Time	t _{FP}	(Notes 1, 2, 5)	0.5		5.0	μs
Programming Current: DQ Pin	I _{PP}	(Notes 2, 5, 7)		6	10	mA

AC ELECTRICAL CHARACTERISTICS: 1-Wire INTERFACE(2.2V ≤ V_{DD} ≤ 5.5V, T_A = -30°C to +85°C.)

PARAMETER	SYMBOL	CONDITIONS	MIN	TYP	MAX	UNITS
Time Slot	t _{SLOT}		60		120	μs
Recovery Time	t _{REC}		1			μs
Write-0 Low Time	t _{LOW0}		60		120	μs
Write-1 Low Time	t _{LOW1}		1		15	μs
Read-Data Valid	t _{RDV}				15	μs
Reset-Time High	t _{RSTH}		480			μs
Reset-Time Low	t _{RSTL}		480		960	μs
Presence-Detect High	t _{PDH}		15		60	μs
Presence-Detect Low	t _{PDL}		60		240	μs
Delay to Program Pulse	t _{DP}		5			μs
Delay to Verify	t _{DV}		5			μs
DQ Capacitance	C _{DQ}			50		pF

Note 1: All voltages are referenced to V_{SS}.**Note 2:** Programming of the EPROM Data and EPROM Status fields require a limited temperature range of 0°C to 50°C and limited V_{DD} voltage range of 3.0V to 5.5V.**Note 3:** Storage for t_{EES} at +50°C.**Note 4:** DQ < V_{IL} for t > 1.5ms or DQ > V_{IH} for t > 1.5ms [1-Wire oscillator shut down].**Note 5:** Programming pulse on DQ pin must be shaped to conform with rise, fall, and width timing specifications. See Figure 7. EPROM Programming Diagram).**Note 6:** The accumulative duration of all programming pulses for each address must not exceed 5ms.**Note 7:** Specification is guaranteed by design.

PIN DESCRIPTION

PIN	NAME	FUNCTION
1, 3	N.C.	No Connection
2	V _{SS}	Supply GND and Reference for Serial Communication. Attach V _{SS} to battery-pack negative terminal.
4	V _{DD}	Supply Input. Bypass to V _{SS} with 0.01 μ F (typ).
5	DQ	Serial Interface Data I/O Pin. Bidirectional data transmit and receive at 16kbps. Input for programming voltage pulse during EPROM programming. Internal 0.5 μ A pulldown ensures idle mode is entered when no DQ pullup is present.

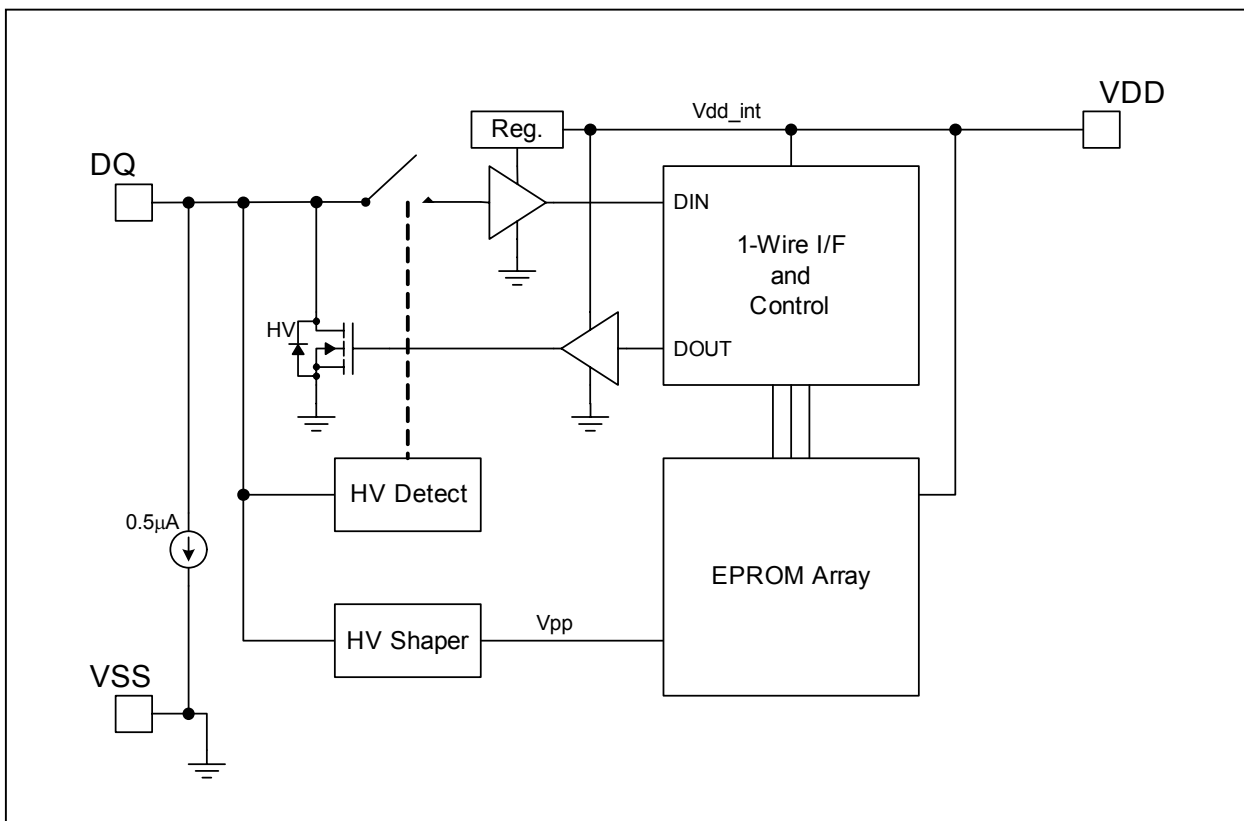
Figure 1. Block Diagram**DETAILED DESCRIPTION**

The DS25LV02 provides battery-pack identification and data storage. A 128-byte EPROM memory array and an 8 byte status field accessed by a low-voltage 1-Wire interface. Each DS25LV02 has a unique 64-bit Net Address (ROM ID) for identification.

The EPROM is divided into four 32-byte pages. An additional 8-byte status field provides lock bit and page redirection information to the user. EPROM writing occurs one byte at a time by supplying a 12V pulse on the DQ line in-between each byte written. Each page can be individually locked by clearing the appropriate bit in the Status field. Data is read sequentially from a starting address through the end of the array. CRC verification provides integrity of all read and written data.

Functional compatibility has been maintained between the DS2502 and DS25LV02 at the Net Address/ROM Command and Function Command levels for reading and writing the Memory data and Status data fields.

EPROM MEMORY DATA FIELD

The DS25LV02 has a linear address space for access to the EPROM data field. The EPROM data field is organized as 4 pages of 32 bytes each as shown in Table 1. The Read Memory and Read Data/Generate CRC Memory function commands provide read access to the 1024 bits of the EPROM data field. The Write Memory function command provides write access to the EPROM data field. When received from the factory, the entire 1024-bit EPROM data field is erased and returns logical 1's when read. Bits within the data field are one time programmable. Programming changes the bit value to logical zero from the factory default erased value of a logical 1. Once a bit is programmed, it cannot be set back to a logical 1.

Table 1. EPROM Data Field

ADDRESS (HEX)	DESCRIPTION	READ/WRITE
0000–001F	PAGE 0 (32 bytes)	R/W*
0020–003F	PAGE 1 (32 bytes)	R/W*
0040–005F	PAGE 2 (32 bytes)	R/W*
0060–007F	PAGE 3 (32 bytes)	R/W*
0080–FFFF	Reserved	

* One-time write to "0" for each bit.

READ MEMORY [F0h]

The Read Memory command is used to read data from PAGE 0 to PAGE 3 of the 1024-bit EPROM data field. The bus master follows the command byte with a 2-byte address (TA1 = (T7:T0), TA2 = (T15:T8)) that indicates a starting byte location within the data field. An 8-bit CRC of the command byte and address bytes is computed by the DS25LV02 and read back by the bus master to confirm that the correct command word and starting address were received. If the CRC is deemed to be incorrect by the bus master, the bus master should issue a reset pulse and repeat the entire sequence. If the CRC is deemed to be correct by the bus master, read time slots can be issued to receive data from the EPROM data field starting at the initial address. The bus master can issue a reset pulse at any point or continue to issue read time slots until the end of PAGE 3 of the data field is reached.

If reading continues through the end of PAGE 3, the bus master can issue eight additional read time slots and the DS25LV02 will respond with a 8-bit CRC of all data bytes read from the initial starting byte through the last byte of PAGE 3. Terminating the command transaction with a reset pulse prior to reaching the end of PAGE 3 results in a loss of availability of the 8-bit CRC.

READ DATA/GENERATE 8-BIT CRC [C3h]

The Read Data/Generate 8-bit CRC command is used to read data from PAGE 0 to PAGE 3 of the 1024-bit EPROM data field. The bus master follows the command byte with a 2-byte address (TA1 = (T7:T0), TA2 = (T15:T8)) that indicates a starting byte location within the data field. An 8-bit CRC of the command byte and address bytes is computed by the DS25LV02 and read back by the bus master to confirm that the correct command word and starting address were received. If the CRC is deemed to be incorrect by the bus master, the bus master should issue a reset pulse and repeat the entire sequence. If the CRC is deemed to be correct by the bus master, read time slots can be issued to receive data from the EPROM data field starting at the initial address. The bus master can issue a reset pulse at any point or continue to issue read time slots until the end of the 32-byte page is reached. If reading occurs through the end of the 32-byte page, the bus master can issue eight additional read time slots and the DS25LV02 will respond with an 8-bit CRC of all data bytes read from the initial starting byte through the last byte of the current page. After the CRC is received, additional read time slots return data starting with the first byte of the next page. This sequence will continue until the bus master reads PAGE 3 and its accompanying CRC. Thus each page of data can be considered to be 33 bytes long: the 32 bytes of user-programmed EPROM data and an 8-bit CRC that gets generated automatically at the end of each page. The Read Data/Generate 8-Bit CRC command sequence can be exited at any point by issuing a reset pulse.

WRITE MEMORY [0Fh]

The Write Memory command is used to program the 1024-bit EPROM data field. Programming is performed one or more bytes at a time, with CRCs of the master-to-slave bit stream provided for data integrity. To begin a memory write, the bus master issues the Write Memory function command followed by a 2-byte address argument (TA1 = (T7:T0), TA2 = (T15:T8)) and a 1-byte data argument (D7:D0). The 2-byte address argument sets the starting byte position in the EPROM data field of the first byte to be written. The data argument provides data for the first byte to be written. The master must issue 8 read timeslots following the data argument.

An 8-bit CRC of the command byte, address bytes and data byte computed by the DS25LV02 is returned in the 8 timeslots to enable the master to check the integrity of the communication. If the CRC is deemed to be incorrect by the bus master, the bus master should issue a reset pulse and repeat the entire sequence. If the CRC is deemed to be correct by the bus master, a programming pulse can be issued to program the byte position within the EPROM data field pointed to by T15:T0. Following the programming pulse, the bus master must issue 8 read timeslots. The read timeslots return the EPROM data byte value (least significant bit first) for confirmation by the master.

The bus master can issue a reset pulse at any point after issuing the program pulse to end the write operation, or continue the write operation with the next byte in the EPROM data field. If a the write operation is continued, the DS25LV02 automatically increments the internal address pointer to select the next byte in the EPROM data field, and the new value of T7:T0 is loaded into the 8-bit CRC generator as the starting value. The bus master issues the next 1-byte data argument followed by 8 read timeslots to return the CRC computed by the DS25LV02. The value returned is computed with D7:D0, using T7:T0 as the starting value. If the CRC is deemed to be incorrect by the bus master, the bus master should issue a reset pulse and repeat the entire sequence. If the CRC is deemed to be correct by the bus master, a programming pulse can be issued to program the byte position pointed to by T15:T0. Following the programming pulse, the bus master must issue 8 read timeslots. The read timeslots return the EPROM data byte value (least significant bit first) for confirmation by the master.

The write operation can be continued until the end of the EPROM data field is reached by repeating the sequence of issuing a 1-byte data argument, 8 read timeslots to return CRC, a programming pulse, and 8 read timeslots to return EPROM data.

EPROM STATUS

The DS25LV02 has a separate 8-byte linear address space for access to the EPROM STATUS data field using the Read Status and Write Status function commands.

READ STATUS [AAh]

The Read Status command is used to read data from the EPROM Status data field. The bus master follows the command byte with a 2-byte address (TA1 = (T7:T0), TA2 = (T15:T8)) that indicates a starting byte location within the data field. An 8-bit CRC of the command byte and address bytes is computed by the DS25LV02 and read back by the bus master to confirm that the correct command word and starting address were received. If the CRC is deemed to be incorrect by the bus master, a reset pulse should be issued and the entire sequence repeated. If the CRC is deemed to be correct by the bus master, read timeslots can be issued to receive data starting at the initial address. The bus master can issue a reset pulse at any point or continue to issue read timeslots until the end of the EPROM Status data field is reached. If reading occurs through the end of the EPROM Status data field, the bus master can issue 8 additional read timeslots and the DS25LV02 will respond with a 8-bit CRC of all data bytes read from the initial starting byte through the last byte. Additional read timeslots return logical 1s until the internal address reaches a multiple of 128. Then data is returned from address 0000h. The Read Status command sequence can be ended at any point by issuing a reset pulse.

WRITE STATUS [55h]

The Write Status command is used to program the EPROM status field. To begin a status field write, the bus master issues the Write Status function command followed by a 2-byte address argument (TA1 = (T7:T0), TA2 = (T15:T8)) and a 1-byte data argument (D7:D0). The 2-byte address argument sets the starting byte position in the EPROM status field of the first byte to be written. The data argument provides data for the first byte to be written. The master must issue 8 read timeslots following the data argument.

An 8-bit CRC of the command byte, address bytes, and data byte computed by the DS25LV02 is returned in the 8 timeslots to enable the master to check the integrity of the communication. If the CRC is deemed to be incorrect by the bus master, the bus master should issue a reset pulse and repeat the entire sequence. If the CRC is deemed to

be correct by the bus master, a programming pulse can be issued to program the byte position within the EPROM status field pointed to by T15:T0. Following the programming pulse, the bus master must issue 8 read timeslots. The read timeslots return the EPROM status byte value (least significant bit first) for confirmation by the master.

The bus master can issue a reset pulse at any point after issuing the program pulse to end the write operation, or continue the write operation with the next byte in the EPROM status field. If the write operation is continued, the DS25LV02 automatically increments the internal address pointer to select the next byte in the EPROM status field, and the new value of T7:T0 is loaded into the 8-bit CRC generator as the starting value. The bus master issues the next 1-byte data argument followed by 8 read timeslots to return the CRC computed by the DS25LV02. The value returned is computed with D7:D0, using T7:T0 as the starting value. If the CRC is deemed to be incorrect by the bus master, the bus master should issue a reset pulse and repeat the entire sequence. If the CRC is deemed to be correct by the bus master, a programming pulse can be issued to program the byte position pointed to by T15:T0. Following the programming pulse, the bus master must issue 8 read timeslots. The read timeslots return the EPROM status byte value (least significant bit first) for confirmation by the master.

The write operation can be continued until the end of the EPROM status field is reached by repeating the sequence of issuing a 1-byte data argument, 8 read timeslots to return CRC, a programming pulse, and 8 read timeslots to return EPROM byte value.

Table 2. EPROM Status Field

ADDRESS (HEX)	DESCRIPTION	READ/WRITE
0000	Write Protect Page bits B0: Page 0 Write Protect B1: Page 1 Write Protect B2: Page 2 Write Protect B3: Page 3 Write Protect B4: Reserved for TMEX B5: Reserved for TMEX B6: Reserved for TMEX B7: Reserved for TMEX	R/W*
0001	Page Redirection Byte for Page 0	R/W*
0002	Page Redirection Byte for Page 1	R/W*
0003	Page Redirection Byte for Page 2	R/W*
0004	Page Redirection Byte for Page 3	R/W*
0005-0006	Reserved	R
0007	Factory Programmed to 00h	R

* One-time write to "0" for each bit.

Table 3. EPROM Memory and Status Function Commands

COMMAND	HEX	FUNCTION
Read Memory	F0	Read data from the lower 1024 bits of the 1024-bit EPROM Memory data field. Generates a CRC value if a read continues through the end of the last page.
Read Data/Generate CRC	C3	Read data from the lower 1024 bits of the 1024-bit EPROM Memory data field. Generates a CRC value of the data if read continues through the end of the page.
Write Memory	0F	Write data to the EPROM data field.
Read Status	AA	Read data from the 8-byte EPROM status field. Generates a CRC if read continues through the end of the field.
Write Status	55	Write the Page Protection bits and Page Redirection bytes in the EPROM status field.

Note: The Write Memory, Read Memory, Read Data/Generate CRC, Write Status, and Read Status commands filter the target address (TA2:TA1) value with a 007Fh AND mask that limits the addressable size of the EPROM data field and EPROM status field to 1024 bits. Target address values equal to or greater than 0080h (128 decimal) return data from the lower 128 bytes of the respective data field. The result of the filtering is that the internal address wraps around every 128 bytes as the external target address increments in multiples of 128. For instance, each time a read operation crosses a 128-byte boundary (0080h, 0100h, ... FF00h, FF80h) data retrieval begins again at address 0000h. This process repeats until reading occurs through the end of the 64kb memory space addressable by T15:T0. It is also important to note that the filter is applied prior to calculation of the CRC, so that target address values that are multiples of 128 return the same CRC. The CRC values should be considered correct only for T15:T0 in the range of 0000h to 007Fh.

1-Wire BUS SYSTEM

The 1-Wire bus is a system that has a single bus master and one or more slaves. A multidrop bus is a 1-Wire bus with multiple slaves, while a single-drop bus has only one slave device. In all instances, the DS25LV02 is a slave device. The bus master is typically a microprocessor in the host system. The discussion of this bus system consists of five topics: 64-bit net address, CRC generation, hardware configuration, transaction sequence, and 1-Wire signaling.

64-BIT NET ADDRESS (ROM ID)

Each DS25LV02 has a unique, factory-programmed 1-Wire Net Address that is 64 bits in length. The term Net Address is synonymous with the ROM ID or ROM Code terms used in the DS2502 and older Dallas 1-Wire documentation. The first 8 bits of the Net Address are the 1-Wire family code (09h for the standard DS25LV02). The next 48 bits are a unique serial number. The last 8 bits are a cyclic redundancy check (CRC) of the first 56 bits (see Figure 2). The 64-bit net address and the 1-Wire I/O circuitry built into the device enable the DS25LV02 to communicate through the 1-Wire protocol detailed in this data sheet.

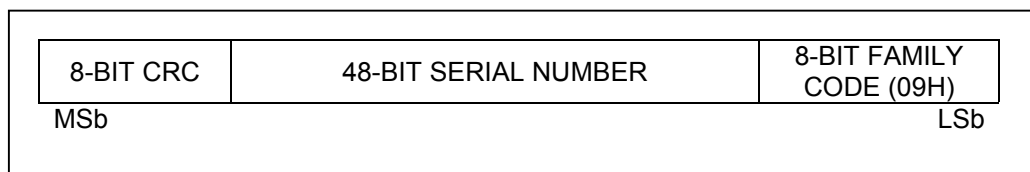
Figure 2. 1-Wire Net Address Format

CRC GENERATION

The DS25LV02 has an 8-bit CRC stored in the most significant byte of its 1-Wire net address and generates a CRC during some command protocols. To ensure error-free transmission of the address, the host system can compute a CRC value from the first 56 bits of the address and compare it to the CRC from the DS25LV02.

The host system is responsible for verifying the CRC value and taking action as a result. The DS25LV02 does not compare CRC values and does not prevent a command sequence from proceeding as a result of a CRC mismatch. Proper use of the CRC can result in a communication channel with a very high level of integrity.

The CRC can be generated by the host using a circuit consisting of a shift register and XOR gates as shown in Figure 3, or it can be generated in software using the polynomial $X^8 + X^5 + X^4 + 1$. Additional information about the Dallas 1-Wire CRC is available in *Application Note 27: Understanding and Using Cyclic Redundancy Checks with Dallas Semiconductor iButton® Products* (www.maxim-ic.com/appnoteindex).

In the circuit in Figure 3, the shift register bits are initialized to 0. Then, starting with the least significant bit of the family code, one bit at a time is shifted in. After the 8th bit of the family code has been entered, then the serial number is entered. After the 48th bit of the serial number has been entered, the shift register contains the CRC value.

Figure 3. 1-Wire CRC Generation Block Diagram

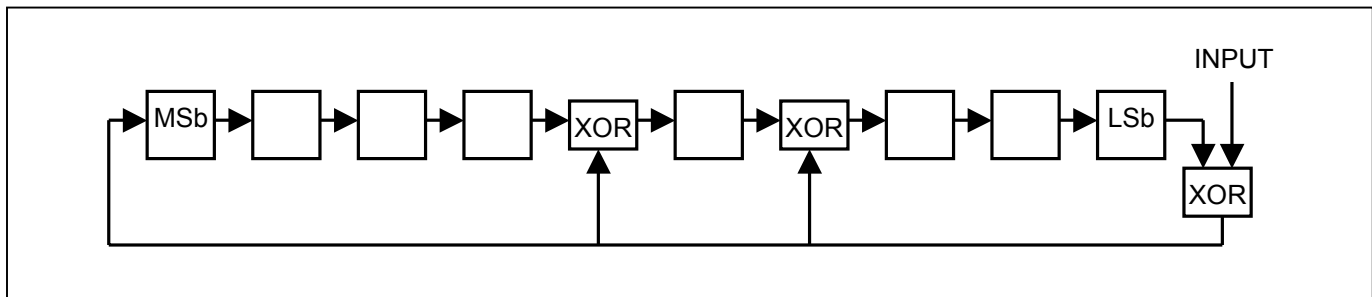

During some command sequences, the DS25LV02 also generates an 8-bit CRC and provides this value to the bus master to facilitate validation for the transfer of command, address, and data from the bus master to the DS25LV02. The DS25LV02 computes an 8-bit CRC for the command and address bytes received from the bus master for the Read Memory, Read Status and Read/Generate CRC commands to confirm that these bytes have been received correctly. The CRC generator on the DS25LV02 is also used to provide verification of error-free data transfer as each EPROM page is sent to the master during a Read Data/Generate CRC command and for the 8 bytes of information in the Status memory field.

In each case where a CRC is used for data transfer validation, the bus master must calculate the CRC value using the same polynomial function and compare the calculated value to the CRC either stored in the DS25LV02 Net Address or computed by the DS25LV02. The comparison of CRC values and decision to continue with an operation are determined entirely by the bus master. There is no circuitry in the DS25LV02 that prevents the command sequence from proceeding if the stored or calculated CRC from the DS25LV02 and the calculated CRC from the host do not match.

HARDWARE CONFIGURATION

Because the 1-Wire bus has only a single line, it is important that each device on the bus be able to drive it at the appropriate time. To facilitate this, each device attached to the 1-Wire bus must connect to the bus with open-drain or tri-state output drivers. The DS25LV02 uses an open-drain output driver as part of the bidirectional interface circuitry shown in Figure 4. If a bidirectional pin is not available on the bus master, separate output and input pins can be connected together.

The 1-Wire bus must have a pullup resistor at the bus-master end of the bus. A value between $2k\Omega$ and $5k\Omega$ is recommended. The idle state for the 1-Wire bus is high. If, for any reason, a bus transaction must be suspended, the bus must be left in the idle state to properly resume the transaction later. Note that if the bus is left low for more

than t_{LOW0} , slave devices on the bus begin to interpret the low period as a reset pulse, effectively terminating the transaction.

Figure 4. 1-Wire Bus Interface Circuitry

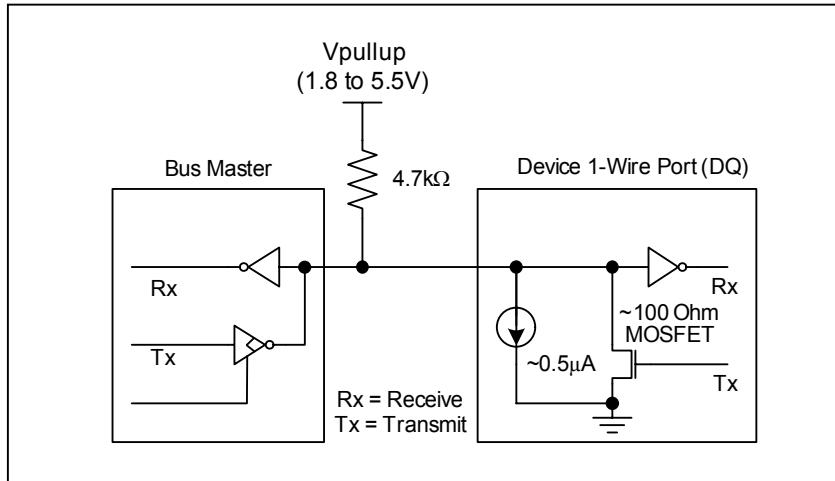

TRANSACTION SEQUENCE

The protocol for accessing the DS25LV02 through the 1-Wire port is as follows:

- Initialization
- Net Address Command
- Function Command(s)
- Data Transfer

All transactions of the 1-Wire bus begin with an initialization sequence consisting of a reset pulse transmitted by the bus master, followed by a presence pulse simultaneously transmitted by the DS25LV02 and any other slaves on the bus. The presence pulse tells the bus master that one or more devices are on the bus and ready to operate. For more details, see below.

NET ADDRESS COMMANDS

Once the bus master has detected the presence of one or more slaves, it can issue one of the net address commands described in the following paragraphs. The name of each Net Address command (ROM command) is followed by the 8-bit opcode for that command in square brackets.

Read Net Address [33h]. This command allows the bus master to read the DS25LV02's 1-Wire net address. The bus master follows the Read Net Address command with 64 read timeslots allowing the 1-Wire slave to transmit its address. This command can only be used if there is a single slave on the bus. If more than one slave is present, a data collision occurs when all slaves try to transmit at the same time (open drain produces a wired-AND result).

Match Net Address [55h]. This command allows the bus master to specifically address one DS25LV02 on the 1-Wire bus. Following this command, the bus master transmits the 64 bit net address of the desired slave device. Only the addressed DS25LV02 responds to any subsequent function command. All other slave devices ignore the function command and wait for a reset pulse. This command can be used with one or more slave devices on the bus.

Skip Net Address [CCh]. This command saves time when there is only one DS25LV02 on the bus by allowing the bus master to issue a function command without specifying the address of the slave. If more than one slave device is present on the bus, a subsequent function command can cause a data collision when all slaves transmit data at the same time.

Search Net Address [F0h]. This command allows the bus master to use a process of elimination to identify the 1-Wire net addresses of all slave devices on the bus. The search process involves the repetition of a simple three-

step routine: read a bit, read the complement of the bit, then write the desired value of that bit. The bus master performs this simple three-step routine on each bit location of the net address. After one complete pass through all 64 bits, the bus master knows the address of one device. The remaining devices can then be identified on additional iterations of the process. Refer to Chapter 5 of the *Book of DS19xx iButton Standards* for a comprehensive discussion of a net address search, including an actual example (www.maxim-ic.com/iButtonBook).

I/O SIGNALING

The 1-Wire bus requires strict signaling protocols to ensure data integrity. The four protocols used by the DS25LV02 are as follows: the initialization sequence (reset pulse followed by presence pulse), write 0, write 1, and read data. The bus master initiates all these types of signaling except the presence pulse.

The initialization sequence required to begin any communication with the DS25LV02 is shown in Figure 5. A presence pulse following a reset pulse indicates that the DS25LV02 is ready to accept a net address command. The bus master transmits (Tx) a reset pulse for t_{RSTL} . The bus master then releases the line and goes into receive mode (Rx). The 1-Wire bus line is then pulled high by the pullup resistor. After detecting the rising edge on the DQ pin, the DS25LV02 waits for t_{PDH} and then transmits the presence pulse for t_{PDL} .

Figure 5. 1-Wire Initialization Sequence

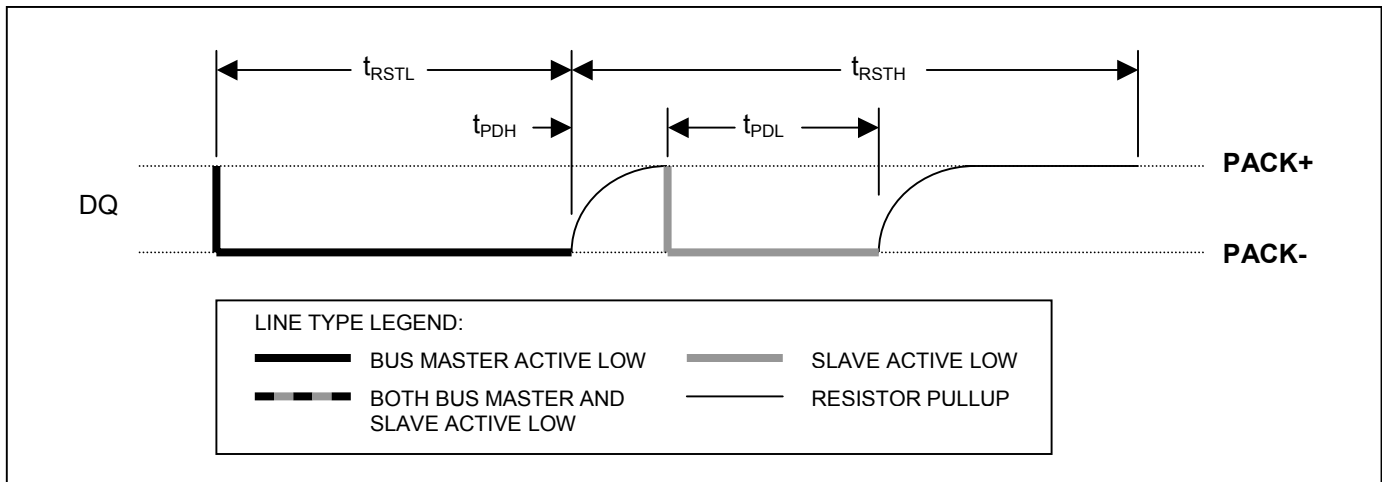

WRITE-TIME SLOTS

A write-time slot is initiated when the bus master pulls the 1-Wire bus from a logic-high (inactive) level to a logic-low level. There are two types of write-time slots: write 1 and write 0. All write-time slots must be t_{SLOT} in duration with a $1\mu s$ minimum recovery time, t_{REC} , between cycles. The DS25LV02 samples the 1-Wire bus line between t_{LOW1_MAX} and t_{LOW0_MIN} after the line falls. If the line is high when sampled, a write 1 occurs. If the line is low when sampled, a write 0 occurs. The sample window is illustrated in Figure 6. For the bus master to generate a write-1 time slot, the bus line must be pulled low and then released, allowing the line to be pulled high less than t_{RDV} after the start of the write time slot. For the host to generate a write-0 time slot, the bus line must be pulled low and held low for the duration of the write-time slot.

READ-TIME SLOTS

A read-time slot is initiated when the bus master pulls the 1-Wire bus line from a logic-high level to a logic-low level. The bus master must keep the bus line low for at least $1\mu s$ and then release it to allow the DS25LV02 to present valid data. The bus master can then sample the data t_{RDV} from the start of the read-time slot. By the end of the read-time slot, the DS25LV02 releases the bus line and allows it to be pulled high by the external pullup resistor. All read-time slots must be t_{SLOT} in duration with a $1\mu s$ minimum recovery time, t_{REC} , between cycles. See Figure 6 and the timing specifications in the *Electrical Characteristics* table for more information.

Figure 6. 1-Wire Write and Read Time Slots

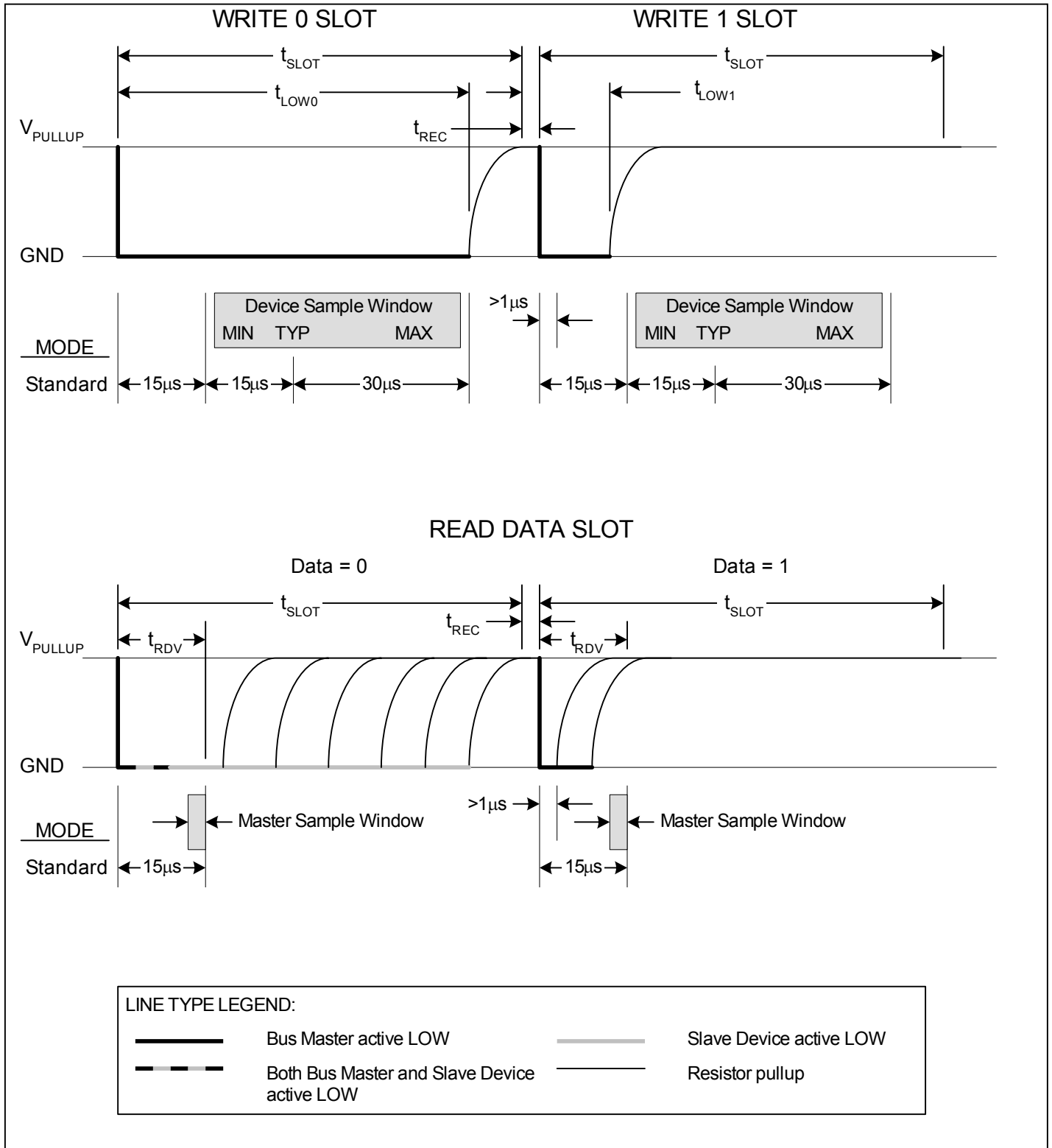
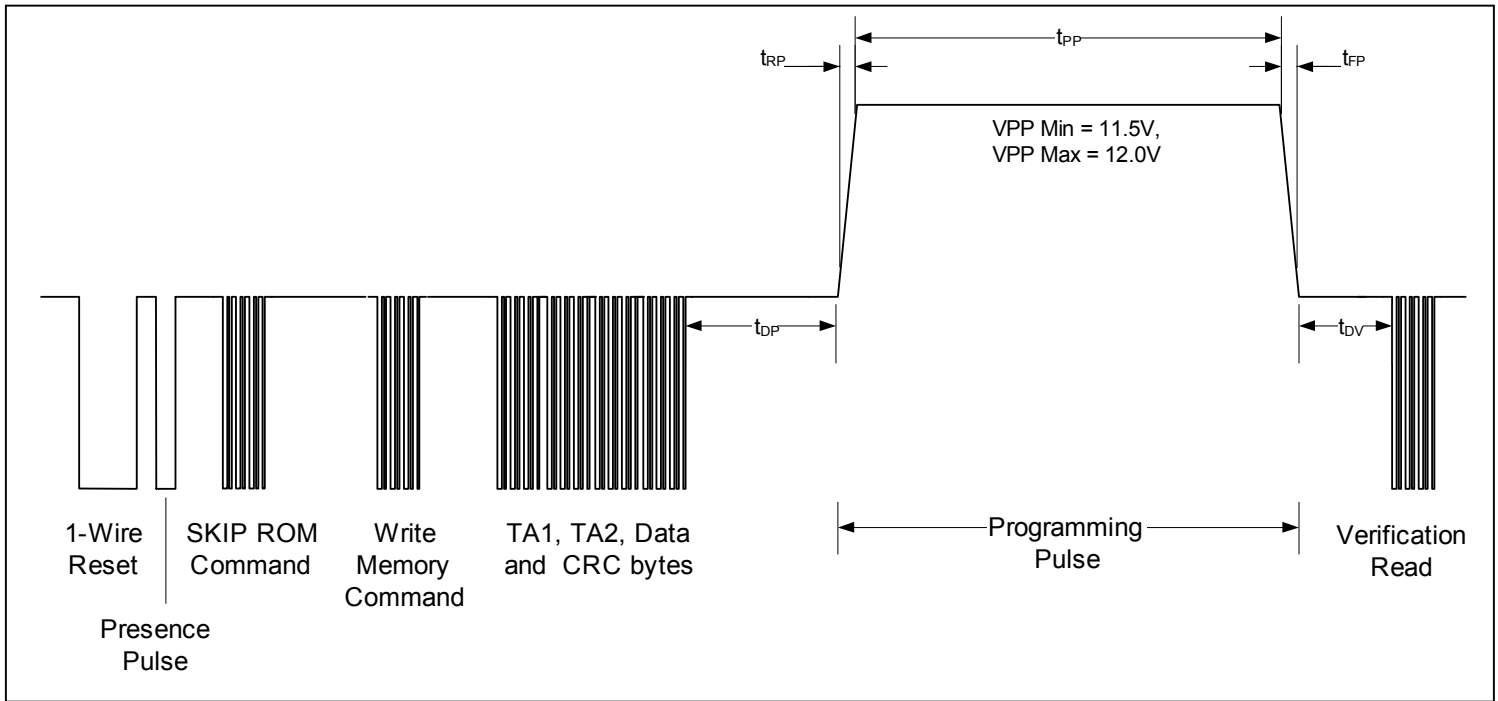

Figure 7. EPROM Programming Diagram



PACKAGE INFORMATION

(For the latest package outline information, go to www.maxim-ic.com/DallasPackInfo.)

Figure 8. Operational Flow Chart

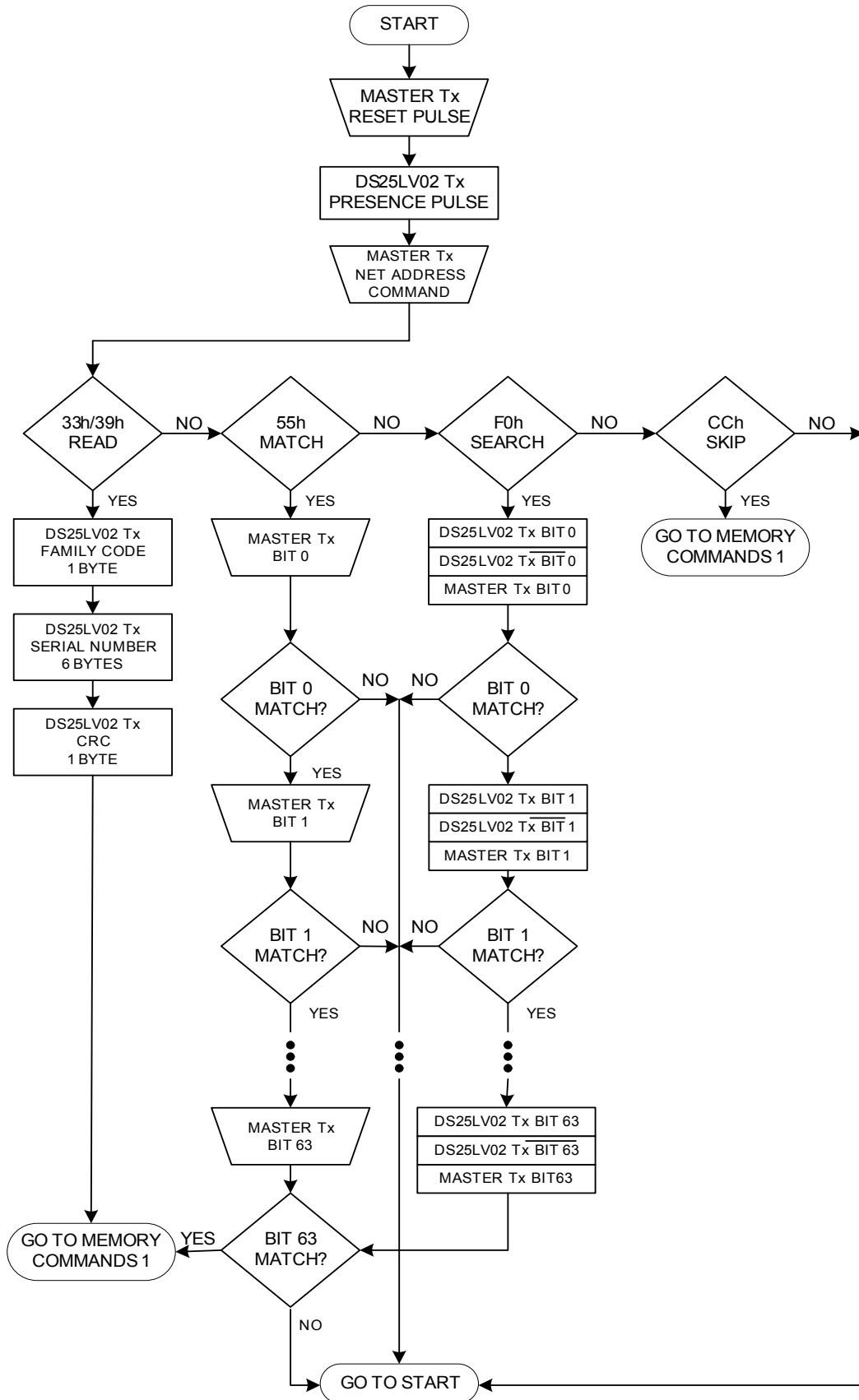

Figure 8. Operational Flow Chart (Continued)

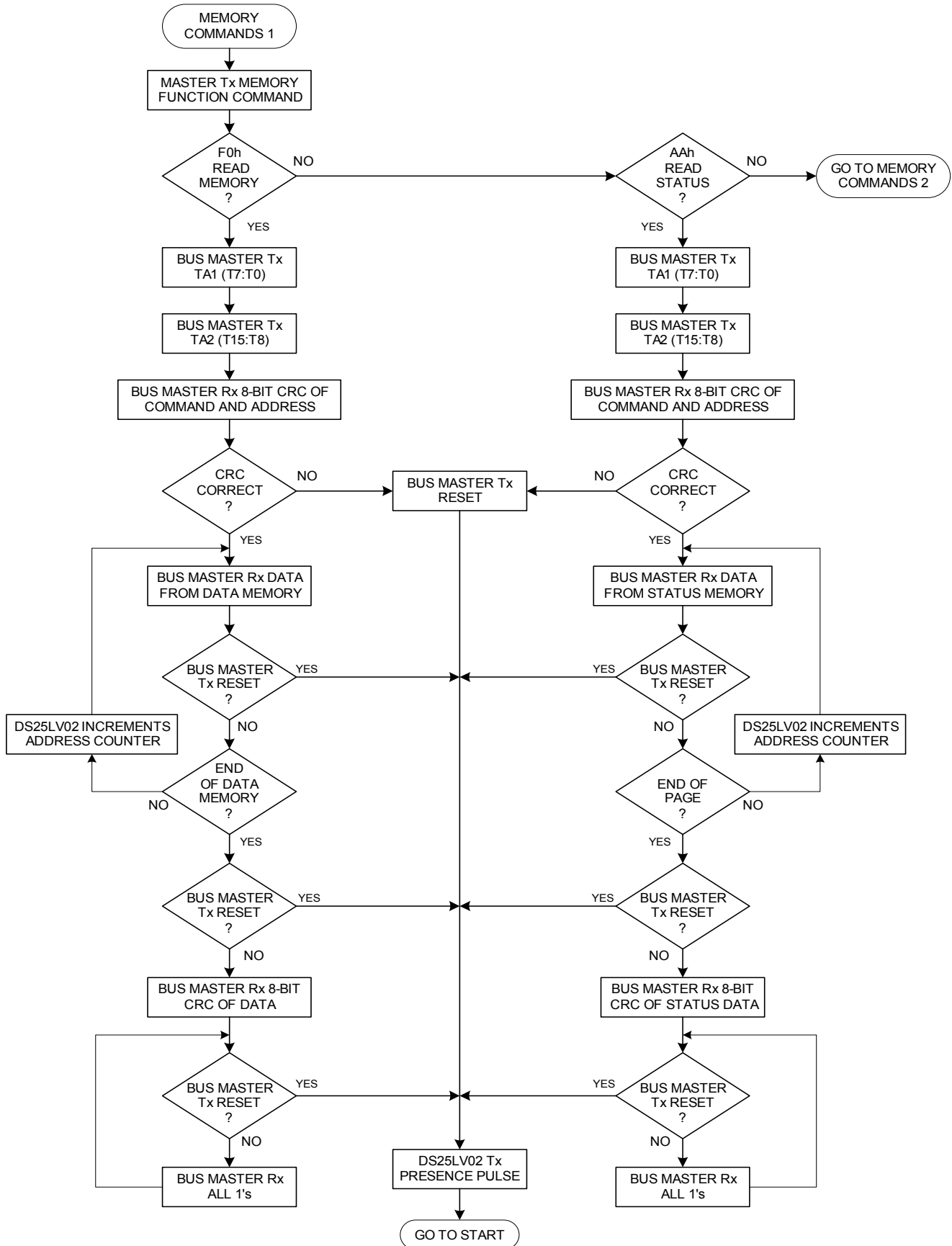

Figure 8. Operational Flow Chart (Continued)

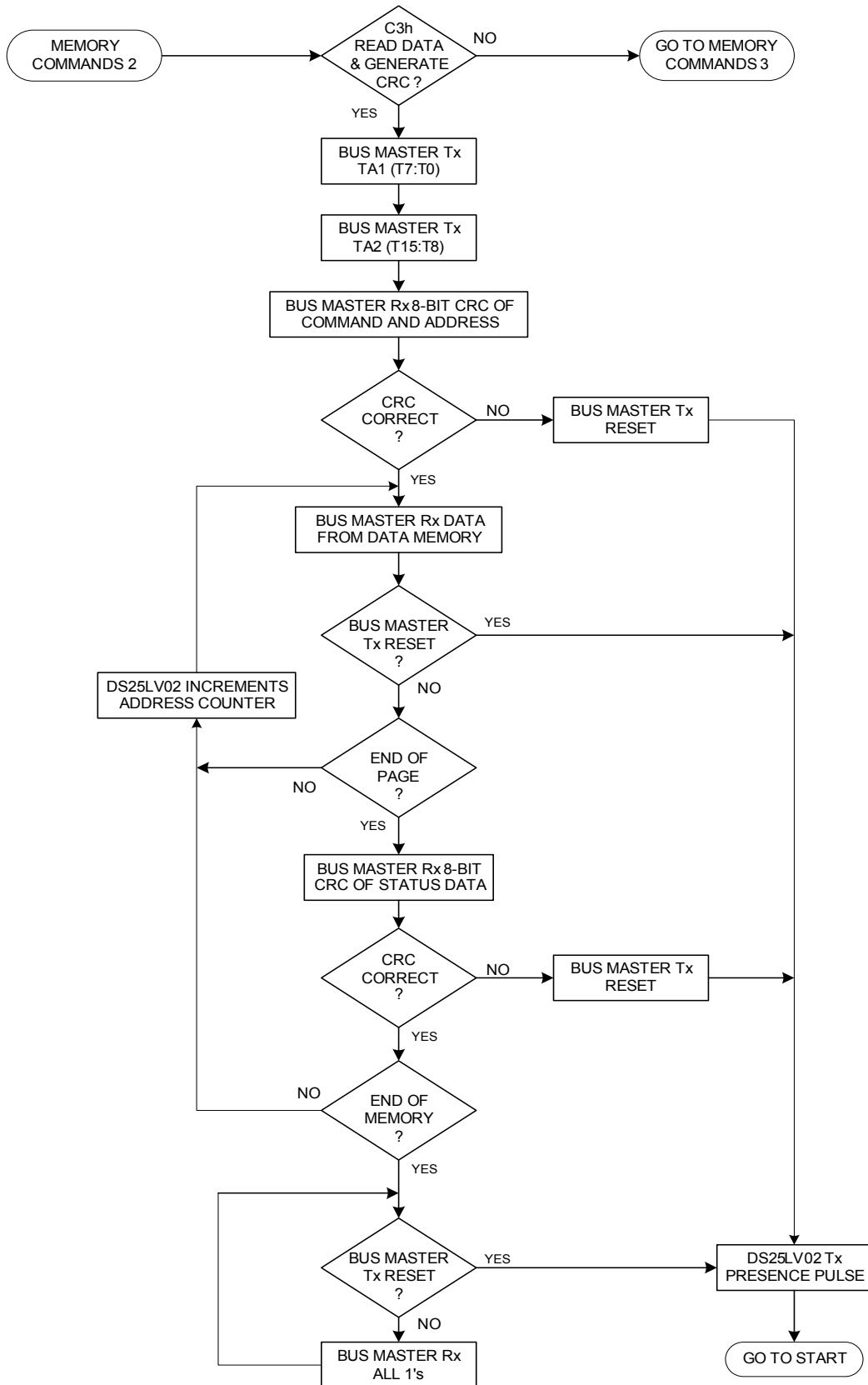

Figure 8. Operational Flow Chart (Continued)

