

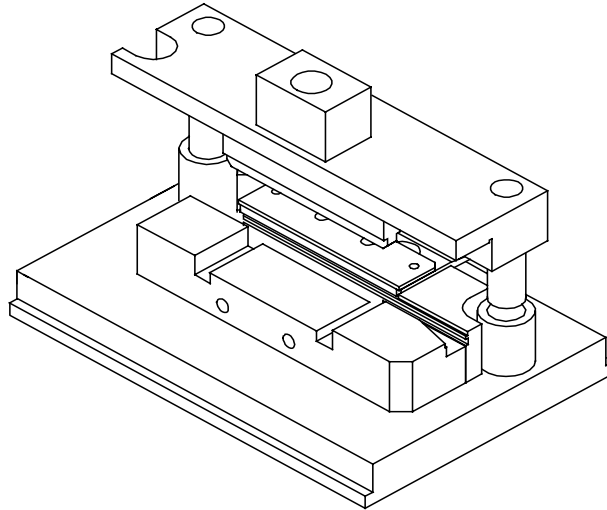

ARBOR PRESS FIXTURE PART No. 69020-0770

FOR MOLEX PRODUCT 7660,7664,7674 and 7675



DESCRIPTION

This fixture will terminate Molex Product 7660,7664,7674 and 7675.

FEATURES

1. This fixture can only be used in a standard Arbor Press part No. 69020-0660.
2. Cables guides and cable stop.
3. For use with notched cable and discrete wire.
4. Colour Bar in/out options included.

SPECIFICATION

SIZE: 210mm x 160mm x 120mm

WEIGHT: 3Kg

WORKING SERVICES: None

SET-UP

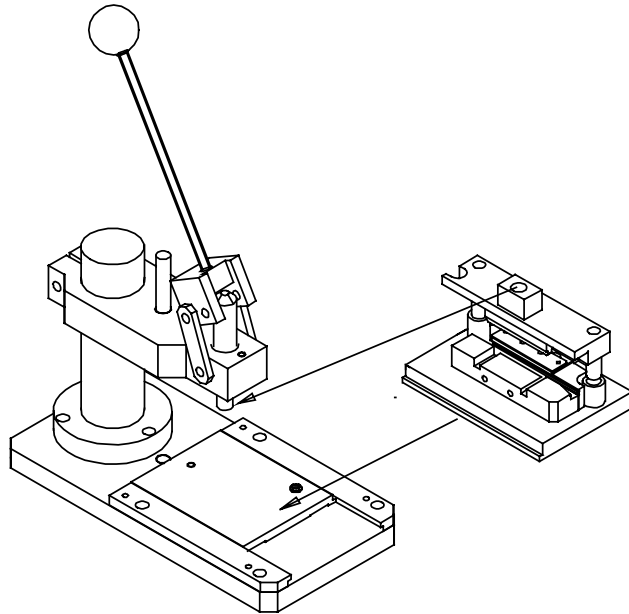

- 1) Fix upper block onto Arbor Press spindle and tighten locking screw.
- 2) Place lower termination fixture onto mounting platform of Arbor Press.
- 3) Make a few samples following the next section (operation) and then check termination heights. If adjustment is required see adjustments section.

OPERATION

- 1) Insert connector into lower termination block.
- 2) Place pre-cut cable over connector.
- 3) Pull handle of Arbor Press down fully to terminate connector.
- 4) Return handle to start position.
- 5) Release connector latch and slide harness backwards out of fixture.

ADJUSTMENTS

- 1) If termination height is incorrect then follow the procedure below.
- 2) Loosen the stud nuts in the centre of the Arbor Press.
- 3) Loosen clamp bolt to column at the rear of the Arbor Press.
- 4) Adjust upper part of Arbor Press up or down using the nuts on the central stud.
- 5) Re-tighten nuts and clamp bolt.
- 6) Recheck termination height.

MAINTENANCE

1. Keep fixture clean at all times.
2. Clean fixture with brush.
3. Oil moving parts weekly, when in use.
4. Store in a clean dry environment.

SPARE PARTS

Number	Description
69020-0415	Insertion blade (LH/RH) 2-off
69020-0416	Insertion blade (Centre) 1-off

Refer to assembly drawing for other parts if required.

QUALITY

Check termination quality against the Molex wire termination specification for relevant product being terminated e.g.: PS-90650.

A quality procedure should be in place to monitor output from this fixture.

LIMITATIONS

This Arbor Press can only be used for product stated in the description section of this leaflet.