

# N032AT23 THRU N362AT23

## List

List..... 1

Package outline..... 2

Features..... 2

Mechanical data..... 2

Maximum ratings ..... 2

Electrical characteristics..... 2

Rating and characteristic curves..... 3

Pinning information..... 4

Marking..... 4

Suggested solder pad layout..... 4

Packing information..... 5

Reel packing..... 6

Suggested thermal profiles for soldering processes..... 6

High reliability test capabilities..... 7

# N032AT23 THRU N362AT23

**Surface Mount TVS  
For ESD Protection Diode - 3.3V - 36V**

**Package outline**

**Features**

- IEC61000-4-2 ESD 15kV Air, 8kV contact compliance
- Protects one bidirectional line or two unidirectional lines
- Peak power dissipation of 400W under 8/20us waveform
- Working voltage : 3.0V, 5.0V, 12V, 24V and 36V
- Low leakage current
- Low operating and clamping voltages
- Sold-state silicon avalanche technology
- Lead-free parts meet environmental standards of MIL-STD-19500 /228
- Suffix "-H" indicates Halogen-free part, ex.N032AT23-H

**Mechanical data**

- Epoxy:UL94-V0 rated flame retardant
- Case : Molded plastic, SOT-23
- Terminals : Solder plated, solderable per MIL-STD-750, Method 2026
- Mounting Position : Any
- Weight : Approximated 0.008 gram

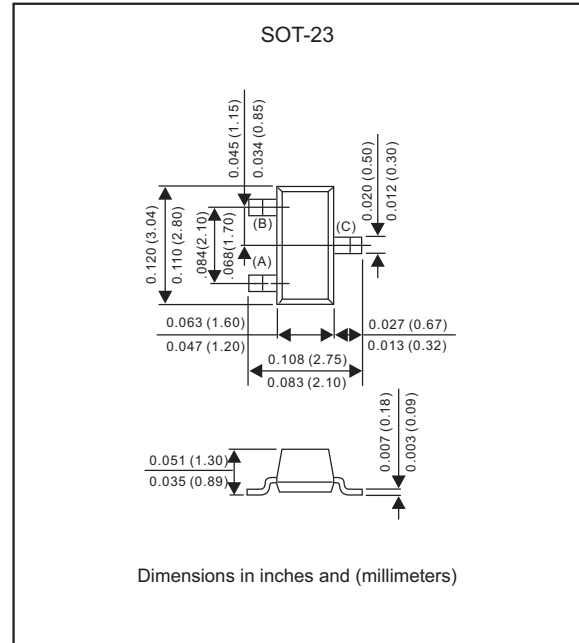

**Maximum ratings** (at T<sub>A</sub>=25°C unless otherwise noted)

Parameter	Condition	Symbol	Value	Unit
Peak pulse power	tp = 8/20 us waveform	P <sub>PP</sub>	400	W
ESD Voltage	HBM Contact AIR Contact	V <sub>ESD</sub>	±8 ±15	kV
Operating junction temperature range		T <sub>J</sub>	-55~+150	°C
Storage temperature range		T <sub>STG</sub>	-55~+150	°C

**Electrical characteristics** (at T<sub>A</sub>=25°C unless otherwise noted)

Part No.	V <sub>RWM</sub> (V) Max.	I <sub>R</sub> (uA) @V <sub>RWM</sub> Max.	V <sub>BR</sub> (V)@I <sub>T</sub> Min.	I <sub>T</sub> (mA)	V <sub>C</sub> (V) tp=8/20us @I <sub>PP</sub> =1.0A Max.	I <sub>PP</sub> (A)	V <sub>C</sub> (V) tp=8/20us @ I <sub>PP</sub> Max.	P <sub>PK</sub> (W) tp=8/20 us Max.	C <sub>J</sub> (pF) 0Vdc,f=1MHZ between I/O pins and GND Max.
N032AT23	3.3	20	4.0	1.0	7.5	25.0	10.0	250	450
N052AT23	5.0	5.0	6.0	1.0	9.8	20.0	12.0	240	350
N122AT23	12.0	1.0	13.3	1.0	19.0	15.0	24.0	360	150
N242AT23	24.0	1.0	26.7	1.0	43.0	10.0	47.0	470	88
N362AT23	36.0	1.0	40.0	1.0	50.0	5.0	75.0	375	80

Rating and characteristic curves (N032AT23 THRU N362AT23)

FIG.1 Pulse Waveform

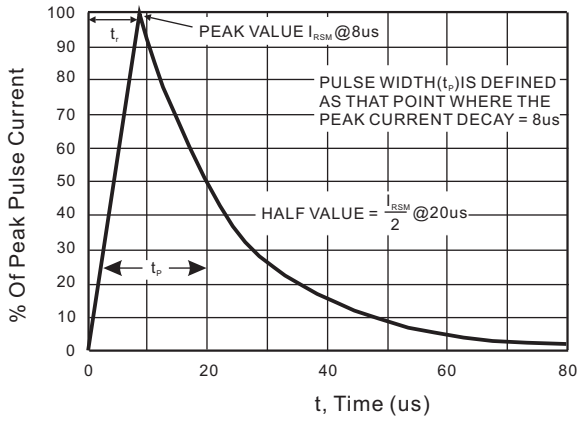

FIG.2 Power Derating Curve

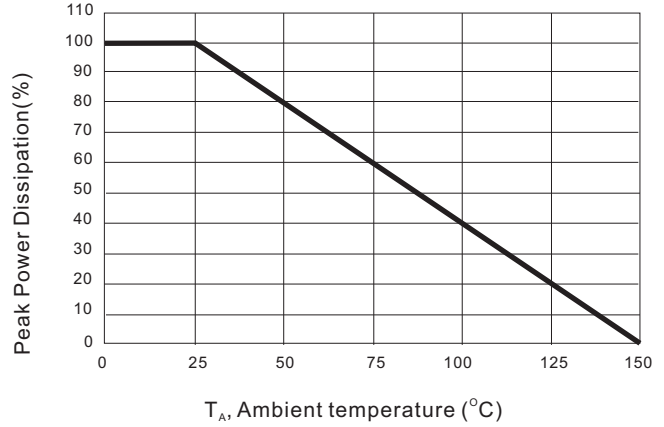

FIG.3 Non-Repetitive Peak Pulse Power vs. Pulse Time

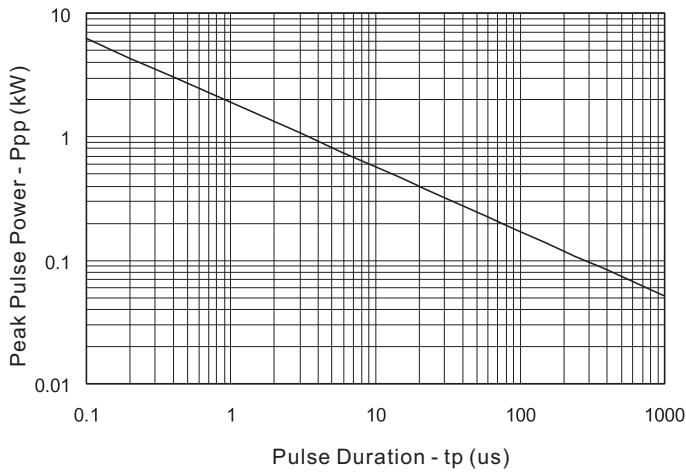
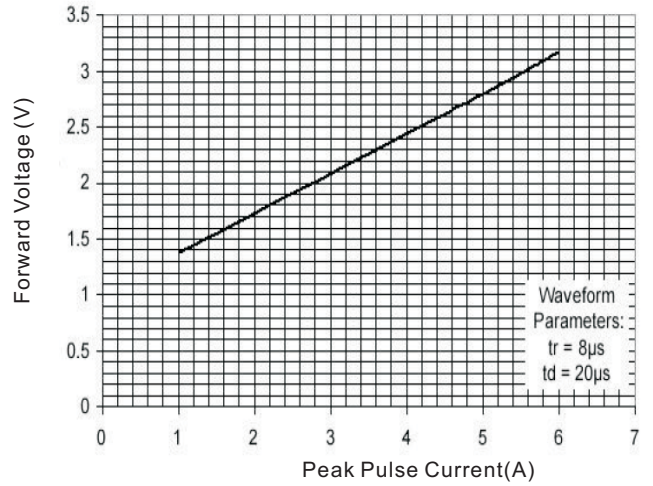

FIG.4 Forward Characteristics



# N032AT23 THRU N362AT23

## Applications

- Cell Phone Handsets and Accessories
- Personal Digital Assistants (PDA's)
- Notebooks, Desktops, and Servers
- Portable Instrumentation
- Set Top Box(STB)
- RS-232, RS-422,RS-423 Protection
- Wireless Bus Protection

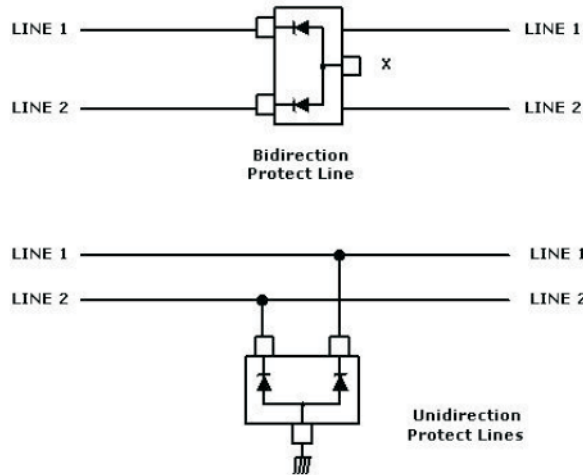

## Pinning information

Type number	Marking code	Symbol
N032AT23	B 03C	
N052AT23	B 05C	
N122AT23	B 12C	
N242AT23	B 24C	
N362AT23	B 36C	

## Suggested solder pad layout

SOT-23

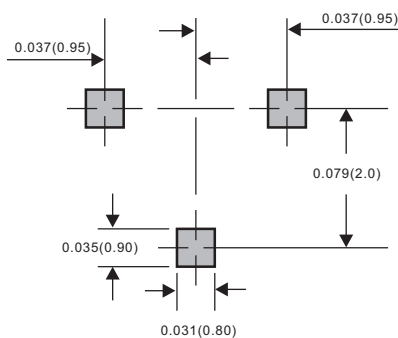

Dimensions in inches and (millimeters)

# N032AT23 THRU N362AT23

## Packing information

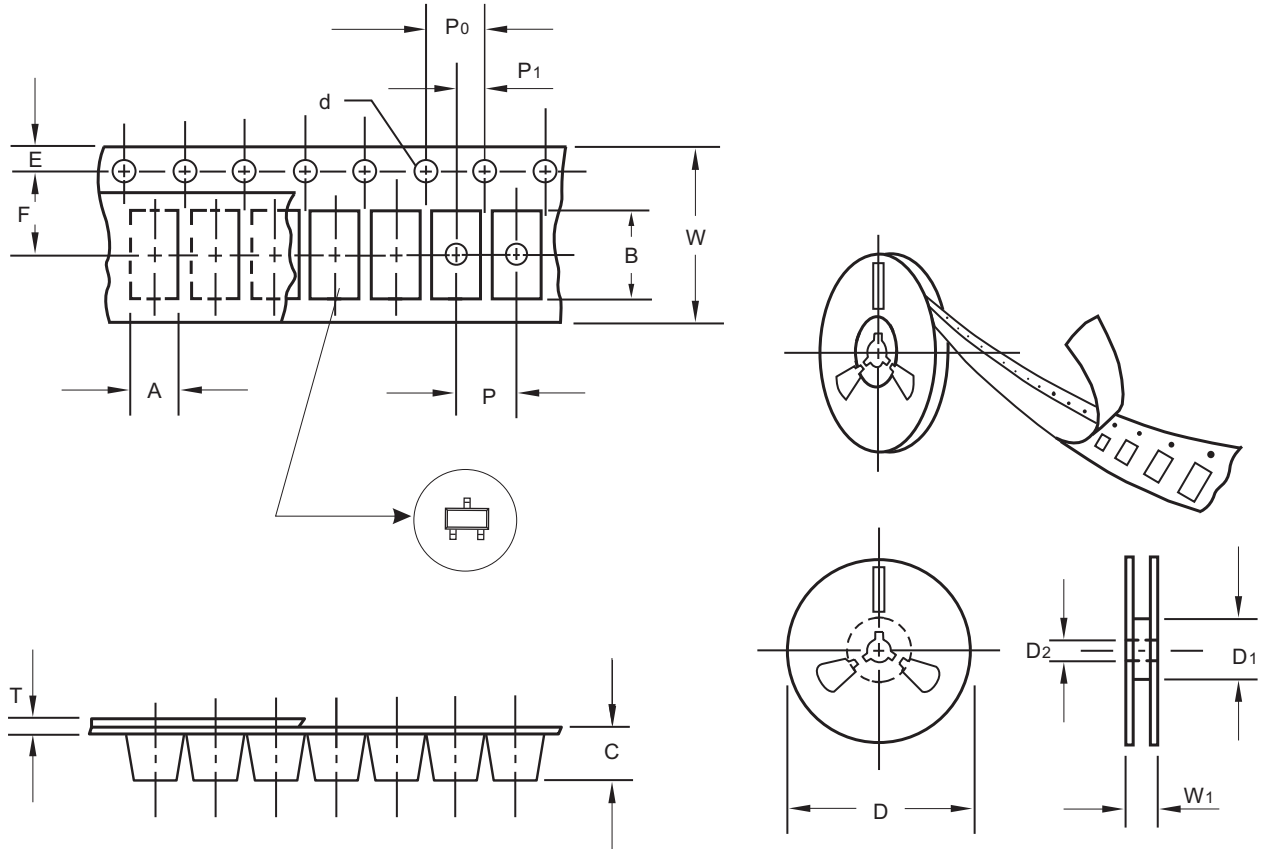

unit:mm

Item	Symbol	Tolerance	SOT-23
Carrier width	A	0.1	3.15
Carrier length	B	0.1	2.77
Carrier depth	C	0.1	1.22
Sprocket hole	d	0.1	1.50
13" Reel outside diameter	D	2.0	-
13" Reel inner diameter	D1	min	-
7" Reel outside diameter	D	2.0	178.00
7" Reel inner diameter	D1	min	62.00
Feed hole diameter	D2	0.5	13.00
Sprocket hole position	E	0.1	1.75
Punch hole position	F	0.1	3.50
Punch hole pitch	P	0.1	4.00
Sprocket hole pitch	P0	0.1	4.00
Embossment center	P1	0.1	2.00
Overall tape thickness	T	0.1	0.23
Tape width	W	0.3	8.00
Reel width	W1	1.0	11.40

Note: Devices are packed in accordance with EIA standard RS-481-A and specifications listed above.

# N032AT23 THRU N362AT23

## Reel packing

PACKAGE	REEL SIZE	REEL (pcs)	COMPONENT SPACING (m/m)	BOX (pcs)	INNER BOX (m/m)	REEL DIA, (m/m)	CARTON SIZE (m/m)	CARTON (pcs)	APPROX. GROSS WEIGHT (kg)
SOT-23	7"	3000	4.0	30,000	183*183*123	178	383*262*387	240,000	11.6

## Suggested thermal profiles for soldering processes

- 1.Storage environment: Temperature=5°C~40°C Humidity=55%±25%
- 2.Reflow soldering of surface-mount devices

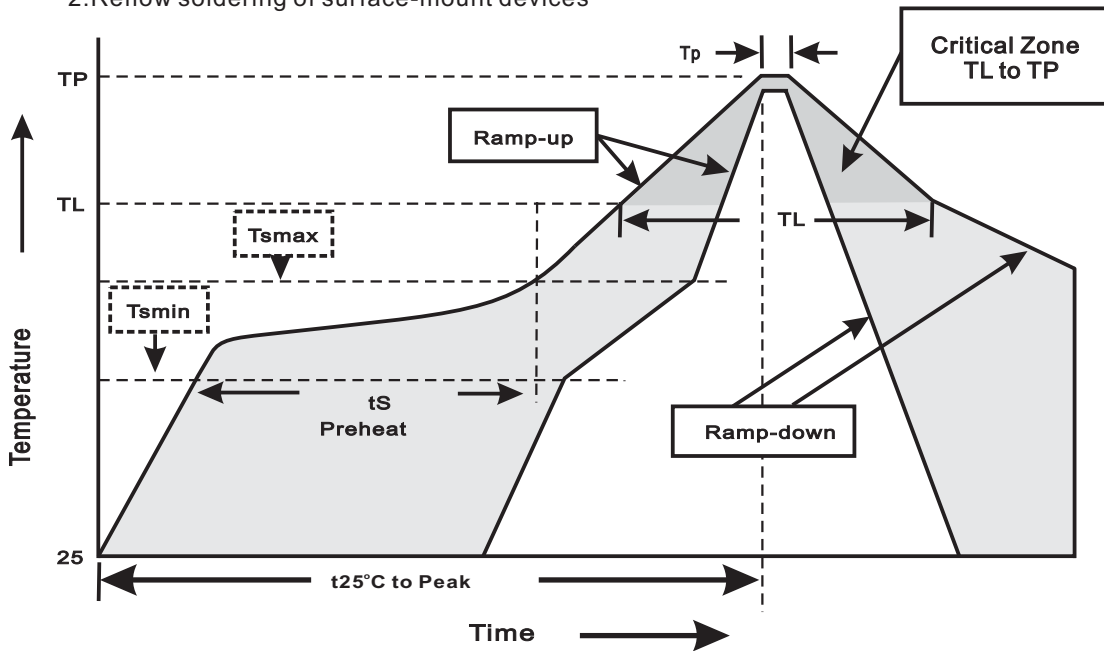

### 3.Reflow soldering

Profile Feature	Soldering Condition
Average ramp-up rate(T <sub>L</sub> to T <sub>P</sub> )	<3°C/sec
Preheat -Temperature Min(T <sub>min</sub> ) -Temperature Max(T <sub>max</sub> ) -Time(min to max)(t <sub>s</sub> )	150°C 200°C 60~120sec
T <sub>max</sub> to T <sub>L</sub> -Ramp-upRate	<3°C/sec
Time maintained above: -Temperature(T <sub>L</sub> ) -Time(t <sub>L</sub> )	217°C 60~260sec
Peak Temperature(T <sub>P</sub> )	255°C-0/+5°C
Time within 5°C of actual Peak Temperature(t <sub>P</sub> )	10~30sec
Ramp-down Rate	<6°C/sec
Time 25°C to Peak Temperature	<6minutes

# N032AT23 THRU N362AT23

## High reliability test capabilities

Item Test	Conditions	Reference
1. Solder Resistance	at $260\pm 5^{\circ}\text{C}$ for $10\pm 2\text{sec.}$ immerse body into solder $1/16''\pm 1/32''$	MIL-STD-750D METHOD-2031
2. Solderability	at $245\pm 5^{\circ}\text{C}$ for 5 sec.	MIL-STD-202F METHOD-208
3. High Temperature Reverse Bias	$V_{\text{RWM}}=80\%$ rate at $T_{\text{J}}=150^{\circ}\text{C}$ for 168 hrs.	MIL-STD-750D METHOD-1038
4. Pressure Cooker	$15P_{\text{SIE}}$ at $T_{\text{A}}=121^{\circ}\text{C}$ for 4 hrs.	JESD22-A102
5. Temperature Cycling	$-55^{\circ}\text{C}$ to $+125^{\circ}\text{C}$ dwelled for 30 min. and transferred for 5min. total 10 cycles.	MIL-STD-750D METHOD-1051
6. Humidity	at $T_{\text{A}}=85^{\circ}\text{C}$ , RH=85% for 1000hrs.	MIL-STD-750D METHOD-1021
7. High Temperature Storage Life	at $175^{\circ}\text{C}$ for 1000 hrs.	MIL-STD-750D METHOD-1031