

TGH Series

120 and 200 Watt SOT227 Package Thick Film Power



Due to their non-inductive design, these resistors are ideally suited for high-frequency and pulse-load applications. Available in 120- or 200-watt sizes, this resistor is designed for direct mounting onto a heatsink. Popular applications include variable speed drives, power supplies, control devices, telecom, robotics, motor controls, and other switching designs.



CHARACTERISTICS

Heat Sink	Nickel-plated copper
Contacts	Nickel-plated copper
Substrate	Al2O3 (96%)
Molding Compound	High-performance epoxy, compliant to UL94-V0
Terminal Nuts	American standard 303 stainless steel
Resistance Range	0.1Ω to 1MΩ
Tolerance	±5%; other tolerances available on request
Temperature coefficient:	±250ppm (at +105°C ref. to +25°C)
Max. Work.Voltage	500V (up to 1,000V on special request)
Power Rating at 85°C	120W (see derating)
Partial Discharge	up to 2,000Vrms/80 pC
Voltage Proof	Dielectric Strength up to 4,000V DC against ground
Heat Resistance to Cooling Plate	R _{th} <0.35 K/W
Capacitance/Mass	45pF
Working Temp. Range	-55°C to +155°C
Max. Torque for Base Plate (static)	1.5 Nm
Max. Torque for Contacts (static)	1.3 Nm. M4 screws (not included)
Derating (thermal resistance)	2.86W/°K (0.35°K/W)

Derating



Configurations

(per package)

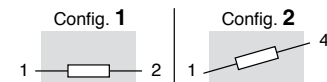

PERFORMANCE DATA

Test Method	ΔR
Moisture Resistance MIL-Std-202, Method 106	(0.5% + 0.001W) max
Thermal shock Mil-Std-202, Method 107, Cond F	(0.3% + 0.01W) max
Terminal Strength MIL-Std-202, Method 211, Cond A (pull test) 2.4N	(0.2% = 0.01W) max
Vibration, High Frequency MIL-Std-202, Method 204, Cond D	(0.2% + 0.01W) max
Life 20 years (120,000 hours) Operating failure rate of 8.3 x 10 ⁻⁷ fail/hour.	

Requirements to be achieved under the following conditions: T_{amb}=25°C, T_{HS}=70°C, P_{applied}=P_n

(continued)

TGH Series

120 and 200 Watt SOT227 Package Thick Film Power

DIMENSIONS

(iin./mm)

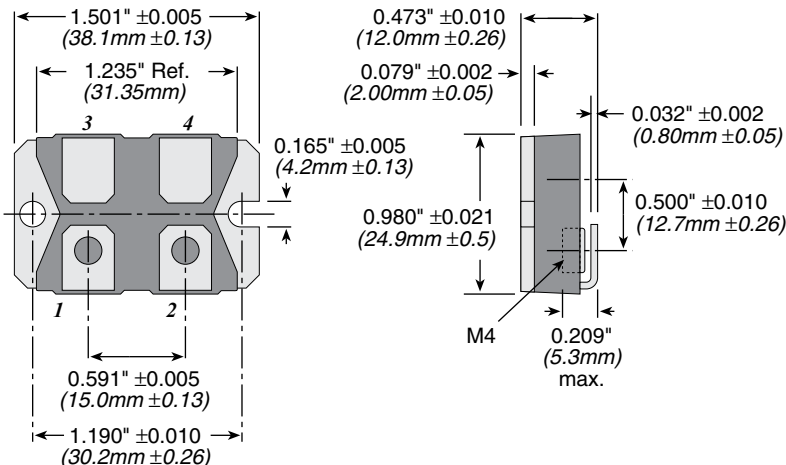

ORDERING INFORMATION

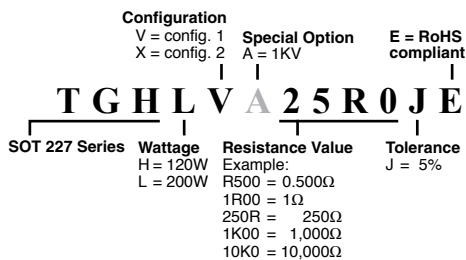

Standard Part Numbers

Ohms	120 Watt TGHH	200 Watt TGH L
0.1	TGHHVR100JE	TGHLVR100JE
0.5	TGHHV1R00JE	TGHLV1R00JE
1	TGHHV5R00JE	TGHLV5R00JE
5	TGHHV10R0JE	TGHLV10R0JE
10	TGHHV33R0JE	TGHLV33R0JE
25	TGHHV50R0JE	TGHLV50R0JE
33	TGHHV100RJE	TGHLV100RJE
50	TGHHV150RJE	TGHLV150RJE
100	TGHHV500RJE	TGHLV500RJE
150	TGHHV680RJE	TGHLV680RJE
500	TGHHV1K00JE	TGHLV1K00JE
680	TGHHV5K00JE	TGHLV5K00JE
1K	TGHHV10K0JE	TGHLV10K0JE
5K		
10K		

THIS PRODUCT IS DESIGNED FOR USE WITH PROPER HEATSINKING.

Maximum base plate temperature of the resistor must be monitored and kept within specified limits to establish the power rating. Best technique is to attach a thermocouple to the side of the base plate of the resistor. Temperature of plastic housing or heat sink cannot be used to establish rating of the resistor.