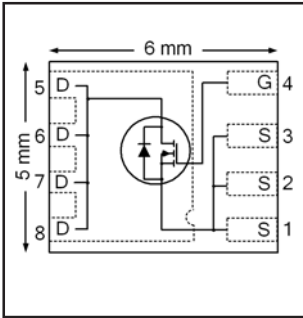


HEXFET® Power MOSFET

|   |              |           |
|---|--------------|-----------|
| $V_{DS}$                                | <b>30</b>    | <b>V</b>  |
| $R_{DS(on) max}$<br>(@ $V_{GS} = 10V$ ) | <b>1.85</b>  | <b>mΩ</b> |
| $Q_g$ (typical)                         | <b>37</b>    | <b>nC</b> |
| $R_G$ (typical)                         | <b>1.5</b>   | <b>Ω</b>  |
| $I_D$<br>(@ $T_{c(Bottom)} = 25°C$ )    | <b>100</b> Ⓢ | <b>A</b>  |



**Applications**

- OR-ing MOSFET for 12V (typical) Bus in-Rush Current
- Synchronous MOSFET for Buck Converters
- Battery Operated DC Motor Inverter MOSFET

**Features and Benefits**

**Features**

|  |
|--|
| Low $R_{DSon}$ (<1.85mΩ)                                     |
| Low Thermal Resistance to PCB (<1.1°C/W)                     |
| 100% $R_g$ tested  |
| Low Profile (<0.9 mm)  |
| Industry-Standard Pinout                                     |
| Compatible with Existing Surface Mount Techniques            |
| RoHS Compliant Containing no Lead, no Bromide and no Halogen |
| MSL1, Industrial Qualification                               |

results in  
⇒

**Benefits**

|                            |
|----------------------------|
| Lower Conduction Losses    |
| Increased Power Density    |
| Increased Reliability      |
| Increased Power Density    |
| Multi-Vendor Compatibility |
| Easier Manufacturing       |
| Environmentally Friendlier |
| Increased Reliability      |

| Orderable part number | Package Type   | Standard Pack |          | Note             |
|-----------------------|----------------|---------------|----------|------------------|
|                       |                | Form          | Quantity |                  |
| IRFH5301TRPbF         | PQFN 5mm x 6mm | Tape and Reel | 4000     |                  |
| IRFH5301TR2PbF        | PQFN 5mm x 6mm | Tape and Reel | 400      | EOL notice # 259 |

**Absolute Maximum Ratings**

|                               | Parameter                                | Max.         | Units |
|-------------------------------|--|--------------|-------|
| $V_{DS}$                      | Drain-to-Source Voltage                  | 30           | V     |
| $V_{GS}$                      | Gate-to-Source Voltage                   | ± 20         |       |
| $I_D @ T_A = 25°C$            | Continuous Drain Current, $V_{GS} @ 10V$ | 35           | A     |
| $I_D @ T_A = 70°C$            | Continuous Drain Current, $V_{GS} @ 10V$ | 28           |       |
| $I_D @ T_{c(Bottom)} = 25°C$  | Continuous Drain Current, $V_{GS} @ 10V$ | 100Ⓢ         |       |
| $I_D @ T_{c(Bottom)} = 100°C$ | Continuous Drain Current, $V_{GS} @ 10V$ | 100Ⓢ         |       |
| $I_{DM}$                      | Pulsed Drain Current ①                   | 400          |       |
| $P_D @ T_A = 25°C$            | Power Dissipation ⑤                      | 3.6          | W     |
| $P_D @ T_{c(Bottom)} = 25°C$  | Power Dissipation ⑤                      | 110          |       |
|                               | Linear Derating Factor ⑤                 | 0.029        | W/°C  |
| $T_J$                         | Operating Junction and                   | -55 to + 150 | °C    |
| $T_{STG}$                     | Storage Temperature Range                |              |       |

Notes ① through ⑥ are on page 8

**Static @ T<sub>J</sub> = 25°C (unless otherwise specified)**

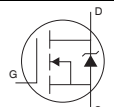
|                                     | Parameter                            | Min.              | Typ.  | Max. | Units | Conditions   |     |   |
|-------------------------------------|--------------------------------------|-------------------|---|------|-------|--|-----|---|
| BV <sub>DSS</sub>                   | Drain-to-Source Breakdown Voltage    | 30                | —   | —    | V     | V <sub>GS</sub> = 0V, I <sub>D</sub> = 250μA   |     |   |
| ΔBV <sub>DSS</sub> /ΔT <sub>J</sub> | Breakdown Voltage Temp. Coefficient  | —                 | 0.02  | —    | V/°C  | Reference to 25°C, I <sub>D</sub> = 1mA  |     |   |
| R <sub>DS(on)</sub>                 | Static Drain-to-Source On-Resistance | —                 | 1.55  | 1.85 | mΩ    | V <sub>GS</sub> = 10V, I <sub>D</sub> = 50A ③  |     |   |
|                                     |                                      | —                 | 2.4   | 2.9  |       | V <sub>GS</sub> = 4.5V, I <sub>D</sub> = 50A ③   |     |   |
| V <sub>GS(th)</sub>                 | Gate Threshold Voltage               | 1.35              | 1.80  | 2.35 | V     | V <sub>DS</sub> = V <sub>GS</sub> , I <sub>D</sub> = 100μA   |     |   |
| ΔV <sub>GS(th)</sub>                | Gate Threshold Voltage Coefficient   | —                 | -6.9  | —    | mV/°C |  |     |   |
| I <sub>DSS</sub>                    | Drain-to-Source Leakage Current      | —                 | —   | 5.0  | μA    | V <sub>DS</sub> = 24V, V <sub>GS</sub> = 0V  |     |   |
|                                     |                                      | —                 | —   | 150  |       | V <sub>DS</sub> = 24V, V <sub>GS</sub> = 0V, T <sub>J</sub> = 125°C  |     |   |
| I <sub>GSS</sub>                    | Gate-to-Source Forward Leakage       | —                 | —   | 100  | nA    | V <sub>GS</sub> = 20V  |     |   |
|                                     | Gate-to-Source Reverse Leakage       | —                 | —   | -100 |       | V <sub>GS</sub> = -20V   |     |   |
| gfs                                 | Forward Transconductance             | 218               | —   | —    | S     | V <sub>DS</sub> = 15V, I <sub>D</sub> = 50A  |     |   |
| Q <sub>g</sub>                      | Total Gate Charge                    | —                 | 77  | —    | nC    | V <sub>GS</sub> = 10V, V <sub>DS</sub> = 15V, I <sub>D</sub> = 50A   |     |   |
| Q <sub>g</sub>                      | Total Gate Charge                    | —                 | 37  | 56   | nC    | V <sub>DS</sub> = 15V<br>V <sub>GS</sub> = 4.5V<br>I <sub>D</sub> = 50A<br>See Fig.6,17 & 18                 |     |   |
|                                     |                                      | Q <sub>gs1</sub>  | Pre-V <sub>th</sub> Gate-to-Source Charge           | —    |       |  | 9.8 | — |
|                                     |                                      | Q <sub>gs2</sub>  | Post-V <sub>th</sub> Gate-to-Source Charge          | —    |       |  | 5   | — |
|                                     |                                      | Q <sub>gd</sub>   | Gate-to-Drain Charge                                | —    |       |  | 12  | — |
|                                     |                                      | Q <sub>godr</sub> | Gate Charge Overdrive                               | —    |       |  | 10  | — |
|                                     |                                      | Q <sub>sw</sub>   | Switch Charge (Q <sub>gs2</sub> + Q <sub>gd</sub> ) | —    |       |  | 17  | — |
| Q <sub>oss</sub>                    | Output Charge                        | —                 | 22  | —    | nC    | V <sub>DS</sub> = 16V, V <sub>GS</sub> = 0V  |     |   |
| R <sub>G</sub>                      | Gate Resistance                      | —                 | 1.5   | 2.3  | Ω     |  |     |   |
| t <sub>d(on)</sub>                  | Turn-On Delay Time                   | —                 | 21  | —    | ns    | V <sub>DD</sub> = 15V, V <sub>GS</sub> = 4.5V<br>I <sub>D</sub> = 15A<br>R <sub>G</sub> = 1.0Ω<br>See Fig.15 |     |   |
| t <sub>r</sub>                      | Rise Time                            | —                 | 78  | —    |       |  |     |   |
| t <sub>d(off)</sub>                 | Turn-Off Delay Time                  | —                 | 22  | —    |       |  |     |   |
| t <sub>f</sub>                      | Fall Time                            | —                 | 23  | —    |       |  |     |   |
| C <sub>iss</sub>                    | Input Capacitance                    | —                 | 5114  | —    | pF    | V <sub>GS</sub> = 0V<br>V <sub>DS</sub> = 15V<br>f = 1.0MHz  |     |   |
| C <sub>oss</sub>                    | Output Capacitance                   | —                 | 1017  | —    |       |  |     |   |
| C <sub>rss</sub>                    | Reverse Transfer Capacitance         | —                 | 406   | —    |       |  |     |   |

**Avalanche Characteristics**

|                 | Parameter                       | Typ. | Max. | Units |
|-----------------|---------------------------------|------|------|-------|
| E <sub>AS</sub> | Single Pulse Avalanche Energy ② | —    | 150  | mJ    |
| I <sub>AR</sub> | Avalanche Current ①             | —    | 50   | A     |

**Diode Characteristics**

|                 | Parameter                                 | Min.                                      | Typ. | Max. | Units | Conditions  |
|-----------------|---|---|------|------|-------|---|
| I <sub>S</sub>  | Continuous Source Current<br>(Body Diode) | —   | —    | 100  | A     | MOSFET symbol<br>showing the<br>integral reverse<br>p-n junction diode. |
| I <sub>SM</sub> | Pulsed Source Current<br>(Body Diode) ①   | —   | —    | 400  |       |   |
| V <sub>SD</sub> | Diode Forward Voltage                     | —   | —    | 1.0  | V     | T <sub>J</sub> = 25°C, I <sub>S</sub> = 50A, V <sub>GS</sub> = 0V ③     |
| t <sub>rr</sub> | Reverse Recovery Time                     | —   | 24   | 36   | ns    | T <sub>J</sub> = 25°C, I <sub>F</sub> = 50A, V <sub>DD</sub> = 15V      |
| Q <sub>rr</sub> | Reverse Recovery Charge                   | —   | 53   | 80   | nC    | di/dt = 300A/μs ③   |
| t <sub>on</sub> | Forward Turn-On Time                      | Time is dominated by parasitic Inductance |      |      |       |   |


**Thermal Resistance**

|                           | Parameter             | Typ. | Max. | Units |
|---------------------------|-----------------------|------|------|-------|
| R <sub>θJC</sub> (Bottom) | Junction-to-Case ④    | —    | 1.1  | °C/W  |
| R <sub>θJC</sub> (Top)    | Junction-to-Case ④    | —    | 15   |       |
| R <sub>θJA</sub>          | Junction-to-Ambient ⑤ | —    | 35   |       |
| R <sub>θJA</sub> (<10s)   | Junction-to-Ambient ⑤ | —    | 22   |       |

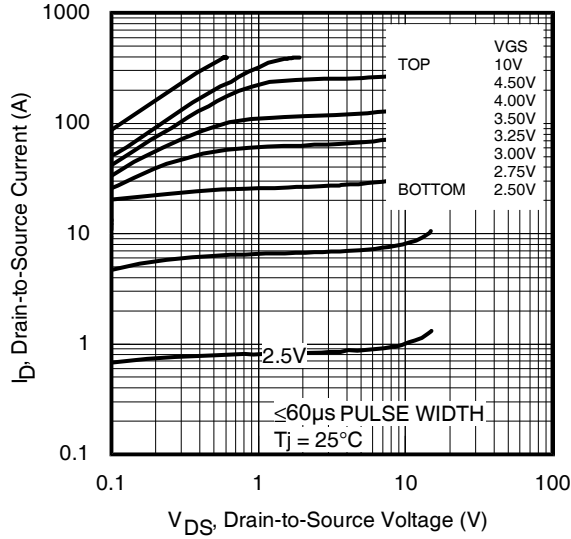


Fig 1. Typical Output Characteristics

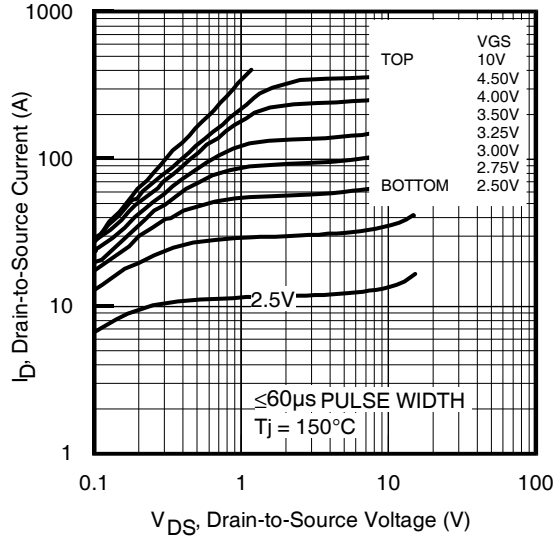


Fig 2. Typical Output Characteristics

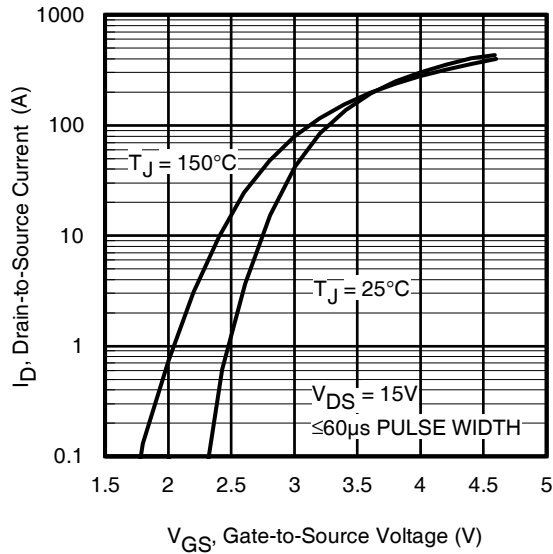


Fig 3. Typical Transfer Characteristics

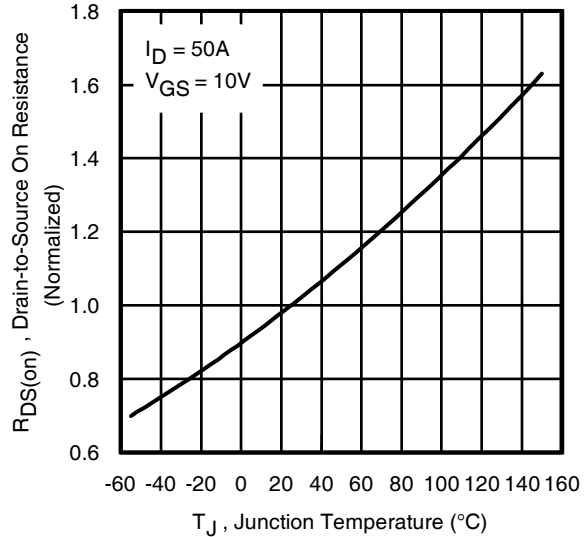


Fig 4. Normalized On-Resistance Vs. Temperature

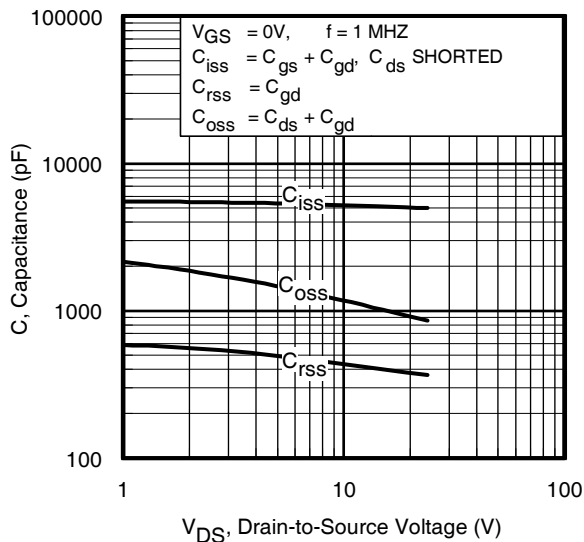


Fig 5. Typical Capacitance Vs. Drain-to-Source Voltage

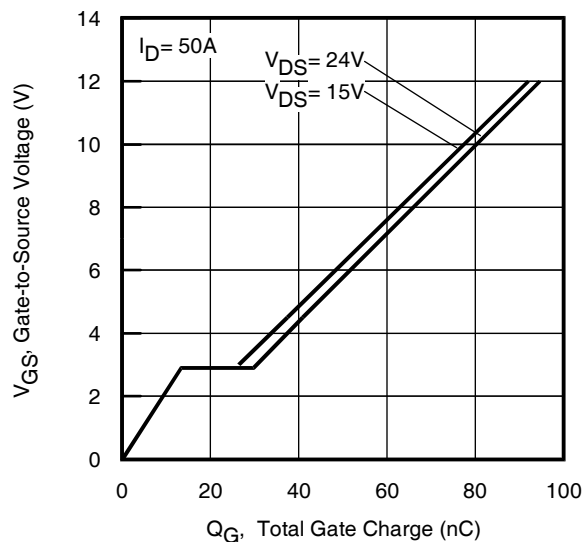
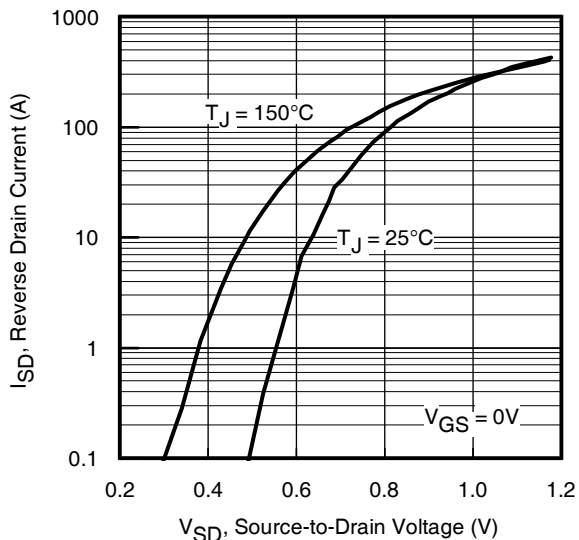
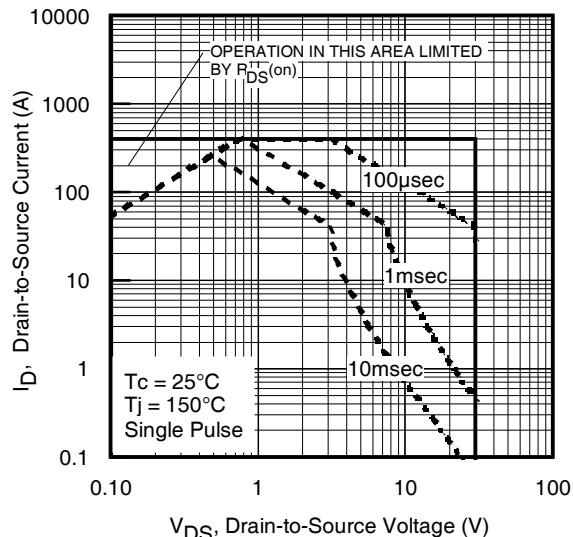


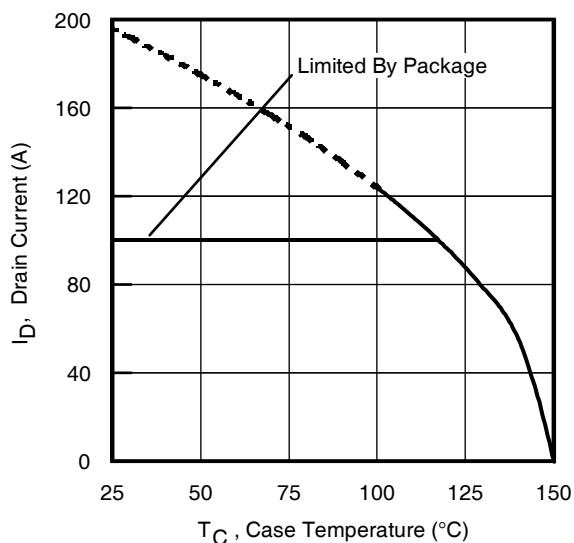
Fig 6. Typical Gate Charge Vs. Gate-to-Source Voltage



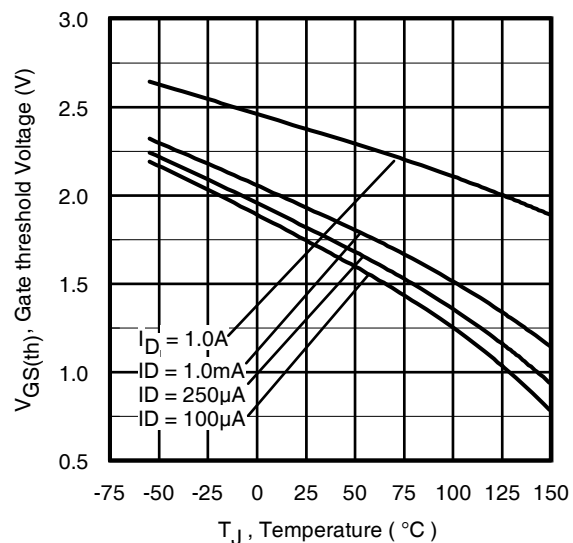
**Fig 7.** Typical Source-Drain Diode Forward Voltage



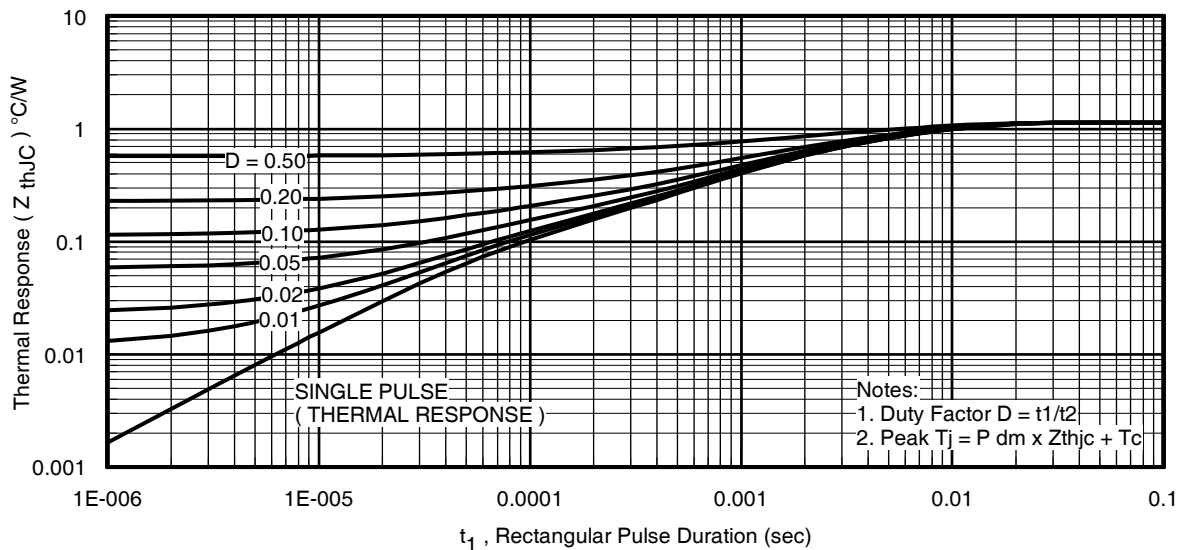
**Fig 8.** Maximum Safe Operating Area



**Fig 9.** Maximum Drain Current Vs. Case (Bottom) Temperature



**Fig 10.** Threshold Voltage Vs. Temperature



**Fig 11.** Maximum Effective Transient Thermal Impedance, Junction-to-Case (Bottom)

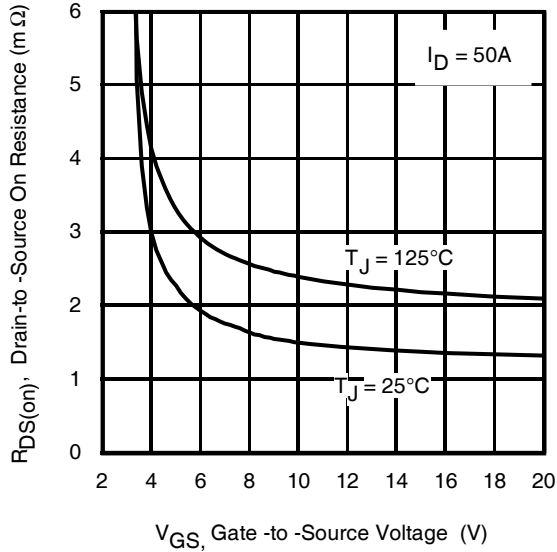


Fig 12. On-Resistance vs. Gate Voltage

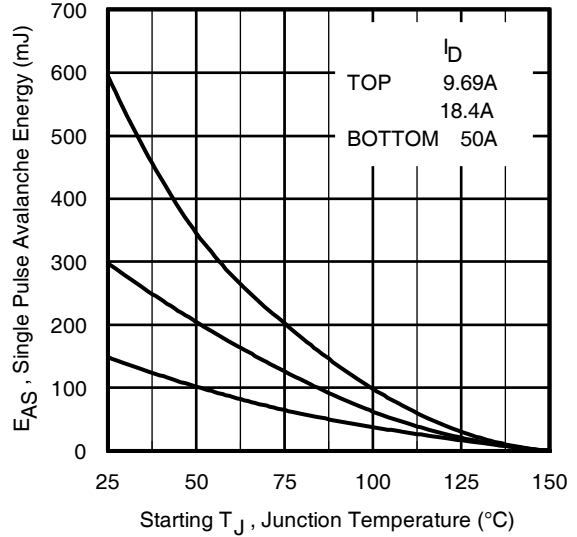


Fig 13. Maximum Avalanche Energy vs. Drain Current

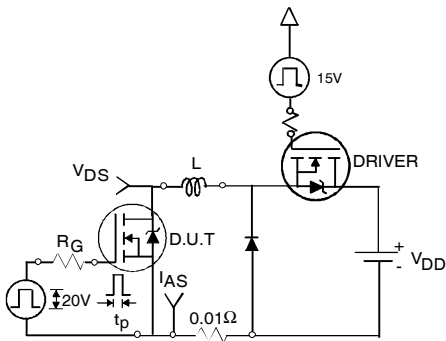


Fig 14a. Unclamped Inductive Test Circuit

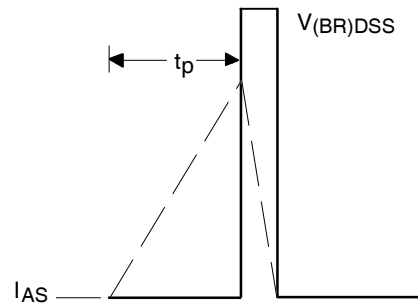


Fig 14b. Unclamped Inductive Waveforms

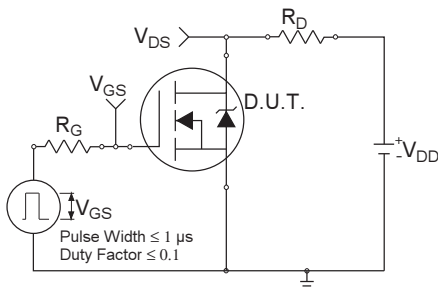


Fig 15a. Switching Time Test Circuit

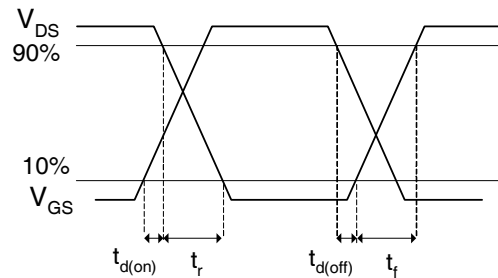
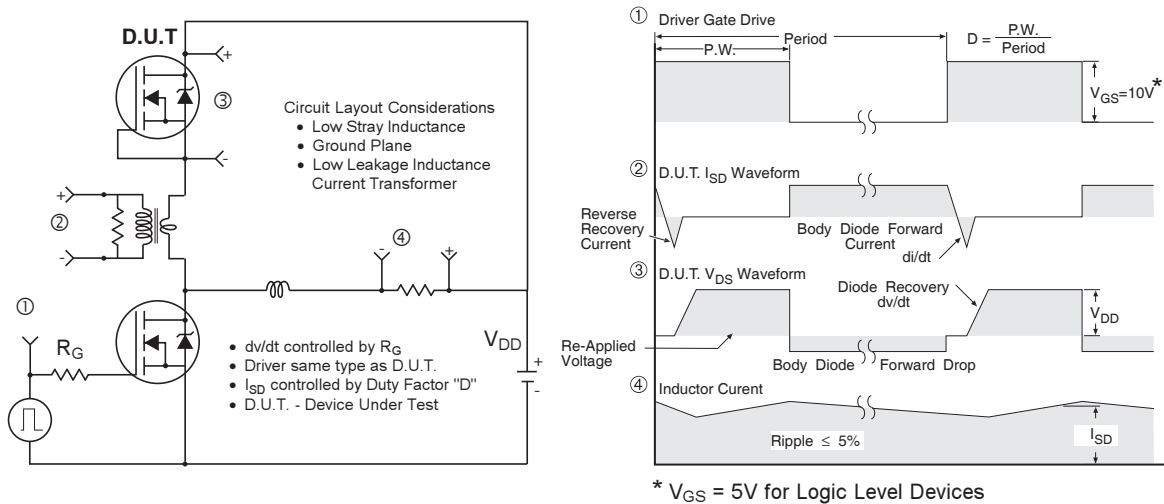
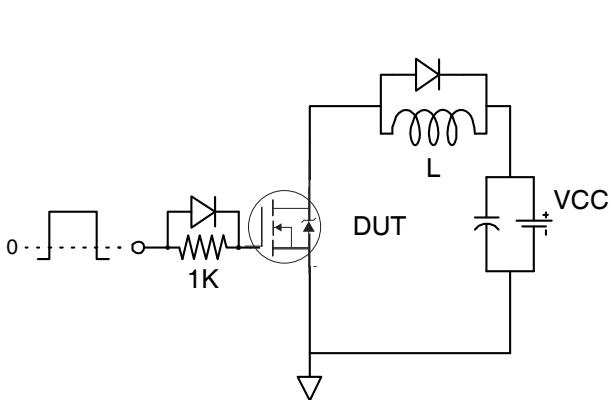


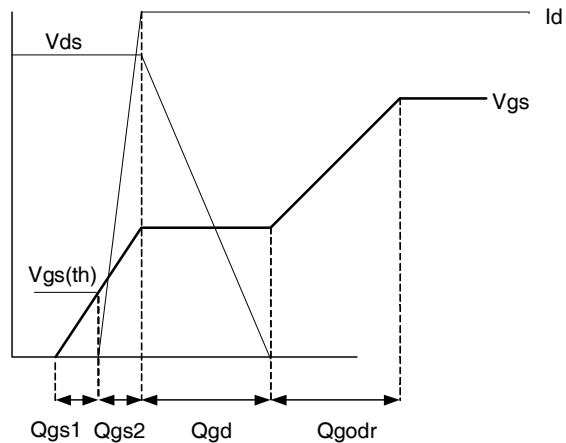
Fig 15b. Switching Time Waveforms



**Fig 16. Peak Diode Recovery  $dv/dt$  Test Circuit for N-Channel HEXFET® Power MOSFETs**

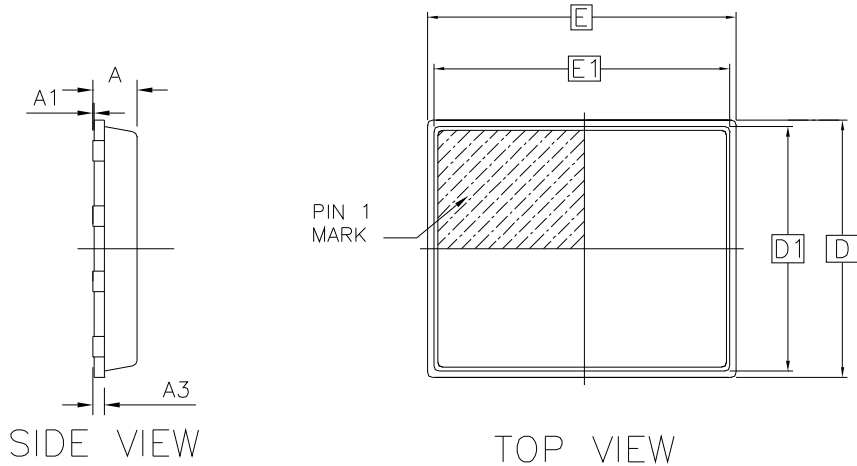


**Fig 17. Gate Charge Test Circuit**

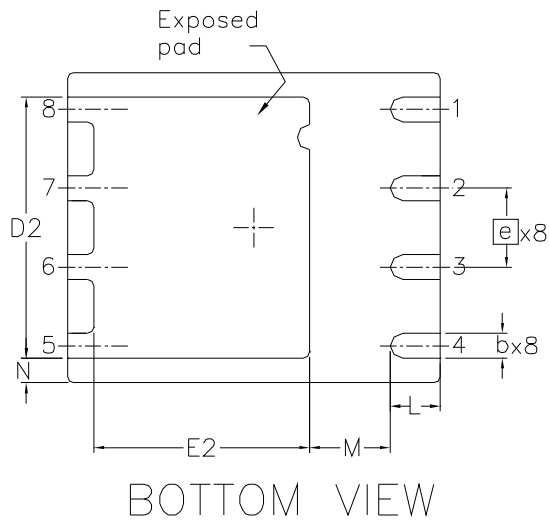


**Fig 18. Gate Charge Waveform**

## PQFN 5x6 Outline "B" Package Details

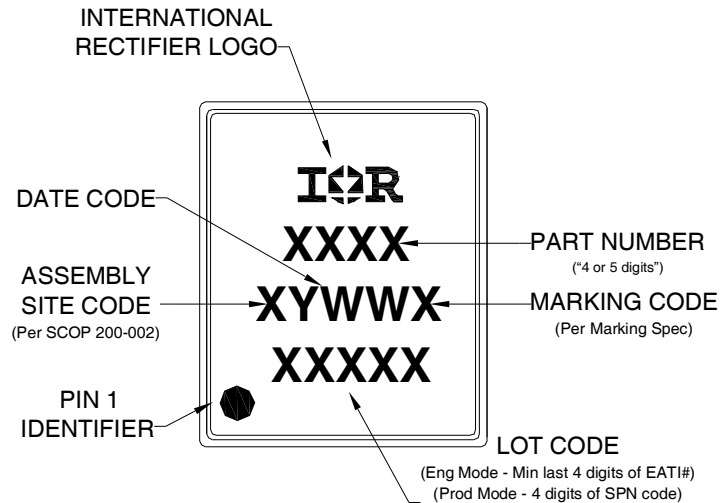


| OUTLINE PQFN 5x6B |      |       |      |
|-------------------|------|-------|------|
| DIM SYMBOL        | MIN  | NOM   | MAX  |
| A                 | 0.80 | 0.83  | 0.90 |
| A1                | 0    | 0.020 | 0.05 |
| A3                |      | 0.20  | REF  |
| b                 | 0.35 | 0.40  | 0.47 |
| D                 |      | 5.00  | BSC  |
| D1                |      | 4.75  | BSC  |
| D2                | 4.10 | 4.21  | 4.30 |
| e                 |      | 1.27  | BSC  |
| E                 |      | 6.00  | BSC  |
| E1                |      | 5.75  | BSC  |
| E2                | 3.38 | 3.48  | 3.58 |
| L                 | 0.70 | 0.80  | 0.90 |
| M                 |      | 1.30  | REF  |
| N                 |      | 0.40  | REF  |



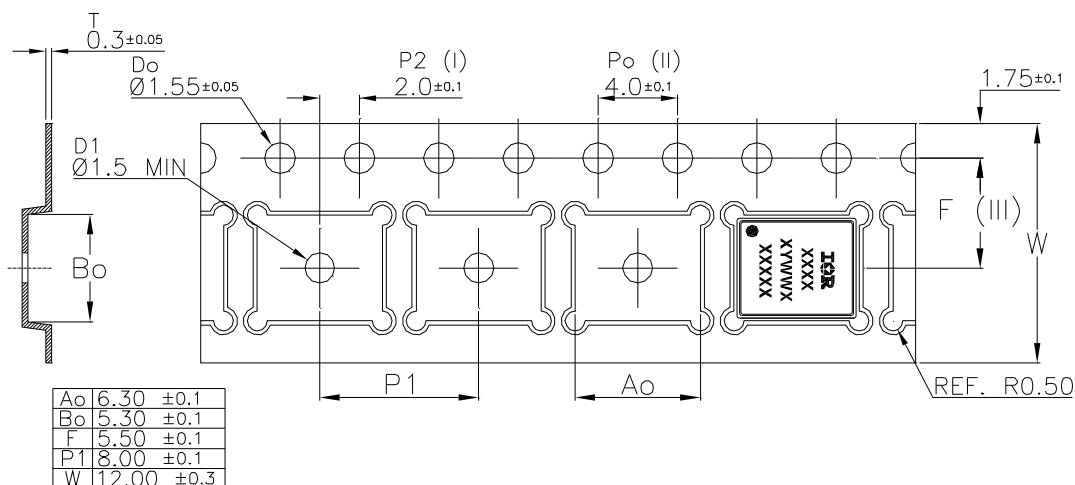
For footprint and stencil design recommendations, please refer to application note AN-1154 at <http://www.irf.com/technical-info/appnotes/an-1154.pdf>

## PQFN 5x6 Outline "B" Part Marking



Note: For the most current drawing please refer to IR website at: <http://www.irf.com/package/>

## PQFN 5x6 Outline "B" Tape and Reel



### Qualification information†

|                            |   |  |
|----------------------------|---|--|
| Qualification level        | Industrial <sup>††</sup><br>(per JEDEC JESD47F <sup>†††</sup> guidelines) |  |
| Moisture Sensitivity Level | PQFN 5mm x 6mm  | MSL1<br>(per JEDEC J-STD-020D <sup>†††</sup> ) |
| RoHS compliant             | Yes   |  |

† Qualification standards can be found at International Rectifier's web site

<http://www.irf.com/product-info/reliability>

†† Higher qualification ratings may be available should the user have such requirements.

Please contact your International Rectifier sales representative for further information:

<http://www.irf.com/whoto-call/salesrep/>

††† Applicable version of JEDEC standard at the time of product release.

### Notes:

- ① Repetitive rating; pulse width limited by max. junction temperature.
- ② Starting  $T_J = 25^\circ\text{C}$ ,  $L = 0.119\text{mH}$ ,  $R_G = 25\Omega$ ,  $I_{AS} = 50\text{A}$ .
- ③ Pulse width  $\leq 400\mu\text{s}$ ; duty cycle  $\leq 2\%$ .
- ④  $R_\theta$  is measured at  $T_J$  of approximately  $90^\circ\text{C}$ .
- ⑤ When mounted on 1 inch square 2 oz copper pad on 1.5x1.5 in. board of FR-4 material.
- ⑥ Calculated continuous current based on maximum allowable junction temperature. Package is limited to 100A by production test capability

### Revision History

| Date       | Comments   |
|------------|--|
| 12/16/2013 | <ul style="list-style-type: none"> <li>• Updated ordering information to reflect the End-Of-life (EOL) of the mini-reel option (EOL notice #259)</li> <li>• Updated data sheet with new IR corporate template</li> </ul> |