

HCL Series

Miniature compensated low pressure sensors

FEATURES

- 0 ... 5 to 0 ... 75 mbar, differential or gage
- Calibrated and temperature compensated
- Matched pressure port volumes
- Miniature SMT and SIL housings
- RoHS compliant

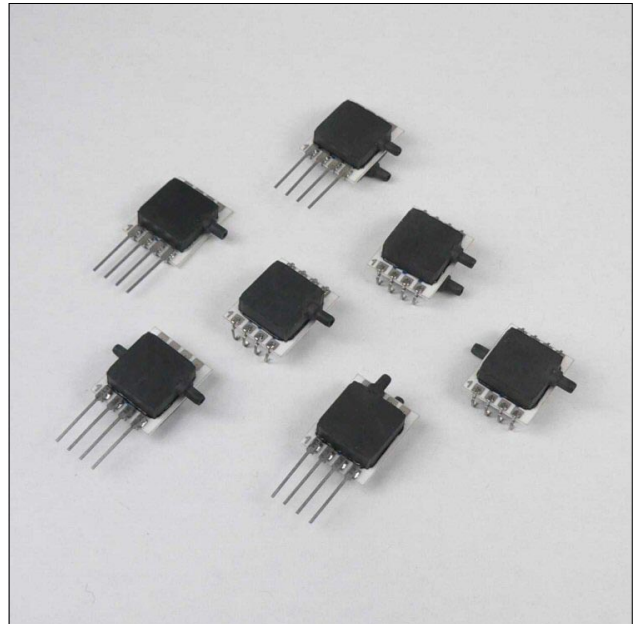

SPECIFICATIONS

Maximum ratings

Supply voltage V_s 16 V_{DC}

Lead specifications

Average preheating temperature gradient 2.5 K/s
Soak time ca. 3 min
Time above 217°C 50 s
Time above 230°C 40 s
Time above 250°C 15 s
Peak temperature 260°C
Cooling temperature gradient -3.5 K/s

Temperature ranges

Compensated
HCL0005..., HCL12x5... 0 ... 50°C
all others 0 ... 70°C
Operating -25 ... 85°C
Storage -40 ... 125°C

Humidity limits (non-condensing) 0 ... 95 %RH

EQUIVALENT CIRCUIT

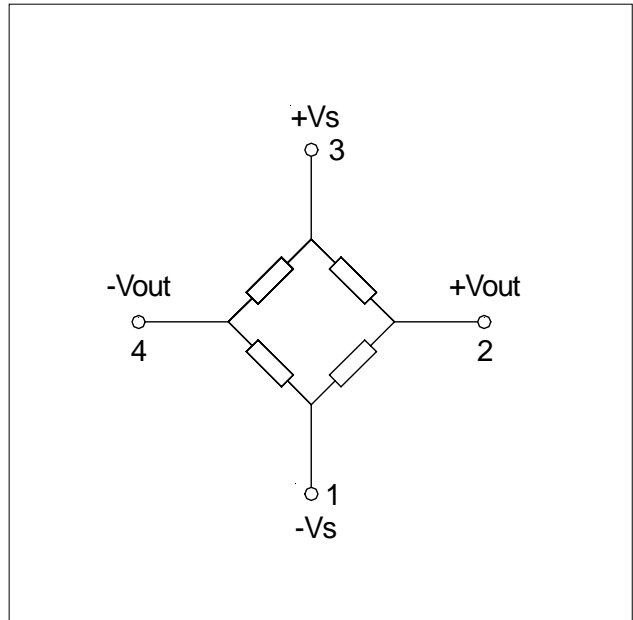

HCL Series

Miniature compensated low pressure sensors

PRESSURE SENSOR CHARACTERISTICS

Part no.	Operating pressure	Proof pressure ^{5,8}	Burst pressure ^{6,8}
HCL0005...	0...5 mbar	250 mbar	500 mbar
HCL12X5...	0...12.5 mbar	250 mbar	500 mbar
HCL0025...	0...25 mbar	500 mbar	750 mbar
HCL0050...	0...50 mbar	750 mbar	1200 mbar
HCL0075...	0...75 mbar	1200 mbar	2000 mbar

PERFORMANCE CHARACTERISTICS

($V_s = 12\text{ V}$, $T_A = 25\text{ °C}$, pressure applied to high pressure port)

HCL0005...

Characteristics	Min.	Nom.	Max.	Units
Zero pressure offset ⁴			±0.5	mV
Full scale span ^{3,4}	5.0 mbar	9.0	11.0	
	10.0 mbar	18.0	22.0	
Combined non-linearity and hysteresis ²		±0.05	±0.25	%FS
Temperature effects (0 to 50°C) ⁷	Offset		±100	µV
	Span at 5.0 mbar		±200	
Offset warm-up shift ¹			±100	
Offset position sensitivity (±1g)		±15	±50	
Offset long term drift (one year)		±80	±200	
Input resistance		4.5		kΩ
Output resistance		1.5		

Specification notes:

1. Shift is within in the first hour of excitation.
2. Non-linearity refers to the **Best Straight Line** fit, measured for offset pressure, full scale pressure and 1/2 full scale pressure.
3. Full scale span is the algebraic difference between the output voltage at full scale pressure and the output voltage at zero pressure.
4. Zero pressure offset and span are ratiometric to the supply voltage.
5. Proof pressure is the maximum pressure which may be applied without causing durable shifts of the electrical parameters of the sensing element.
6. Burst pressure is the maximum pressure which may be applied to one pressure port relative to the other port without causing leaks to the sensor.
7. Shifts are relative to 25°C.
8. The common mode pressure for the HCL series is 2 bar. Common mode pressure is the maximum pressure that can be applied to both ports of a differential pressure sensor simultaneously without damaging the sensor housing.

HCL Series

Miniature compensated low pressure sensors

PERFORMANCE CHARACTERISTICS (cont.)

($V_s = 12\text{ V}$, $T_A = 25\text{ °C}$, pressure applied to high pressure port)

HCL12X5...

Characteristics	Min.	Nom.	Max.	Units	
Zero pressure offset ⁴			±0.5	mV	
Full scale span ^{3,4}	19.0	20.0	21.0		
Combined non-linearity and hysteresis ²		±0.05	±0.25	%FS	
Temperature effects (0 to 50°C) ⁷	Offset		±150	μV	
	Span		±200		
Offset warm-up shift ¹			±50		
Offset position sensitivity (±1g)			±10		
Offset long term drift (one year)			±100		
Input resistance		4.5			kΩ
Output resistance		1.5			

HCL0025...

Characteristics	Min.	Nom.	Max.	Units	
Zero pressure offset ⁴			±0.5	mV	
Full scale span ^{3,4}	19.0	20.0	21.0		
Combined non-linearity and hysteresis ²		±0.05	±0.25	%FS	
Temperature effects (0 to 70°C) ⁷	Offset		±150	μV	
	Span		±200		
Offset warm-up shift ¹			±50		
Offset position sensitivity (±1g)			±5		
Offset long term drift (one year)			±100		
Input resistance		4.5			kΩ
Output resistance		1.5			

HCL Series

Miniature compensated low pressure sensors

PERFORMANCE CHARACTERISTICS (cont.)

($V_s = 12\text{ V}$, $T_A = 25\text{ °C}$, pressure applied to high pressure port)

HCL0050...

Characteristics		Min.	Nom.	Max.	Units	
Zero pressure offset ⁴				±0.5	mV	
Full scale span ^{3,4}		19.0	20.0	21.0		
Combined non-linearity and hysteresis ²			±0.05	±0.25	%FS	
Temperature effects (0 to 70°C) ⁷	Offset			±150	μV	
	Span			±200		
Offset warm-up shift ¹				±50		
Offset position sensitivity (±1g)				±5		
Offset long term drift (one year)				±100		
Input resistance			4.5			kΩ
Output resistance			1.5			

HCL0075...

Characteristics		Min.	Nom.	Max.	Units	
Zero pressure offset ⁴				±0.5	mV	
Full scale span ^{3,4}		19.0	20.0	21.0		
Combined non-linearity and hysteresis ²			±0.05	±0.25	%FS	
Temperature effects (0 to 70°C) ⁷	Offset			±150	μV	
	Span			±200		
Offset warm-up shift ¹				±50		
Offset position sensitivity (±1g)				±5		
Offset long term drift (one year)				±100		
Input resistance			4.5			kΩ
Output resistance			1.5			

HCL Series

Miniature compensated low pressure sensors

PHYSICAL DIMENSIONS AND ELECTRICAL CONNECTIONS

HCL...D...

SIL dual port, same side

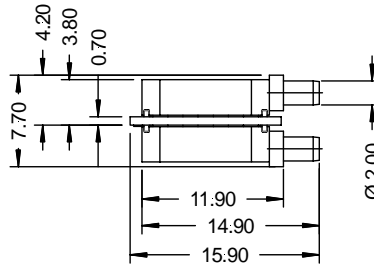
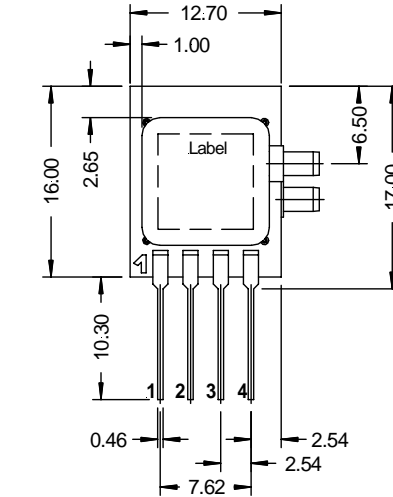
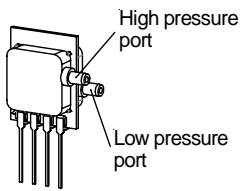
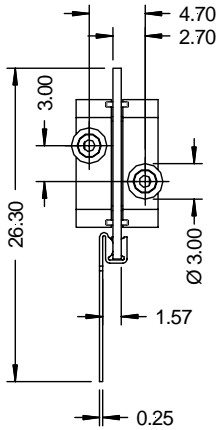

Pin	Connection
1	-Vs
2	+Vout
3	+Vs
4	-Vout

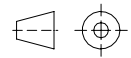

first angle projection

dimensions in mm

HCL...E...

SMD dual port, same side

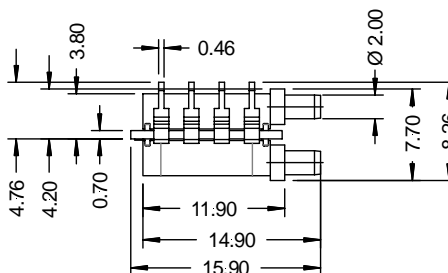
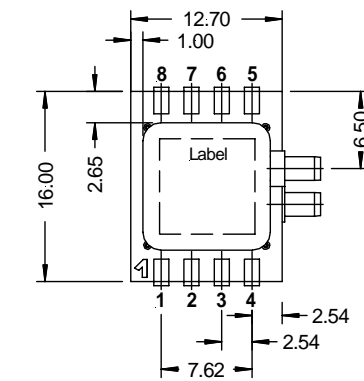
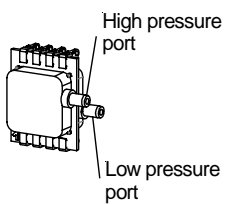
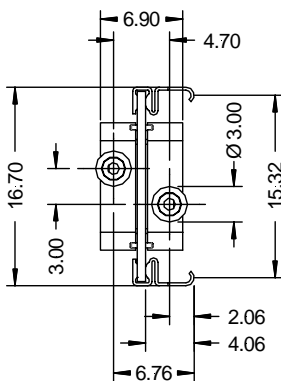

Pin	Connection
1	-Vs
2	+Vout
3	+Vs
4	-Vout
5	N / C
6	
7	
8	

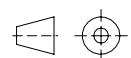

first angle projection

dimensions in mm

HCL Series

Miniature compensated low pressure sensors

PHYSICAL DIMENSIONS AND ELECTRICAL CONNECTIONS (cont.)

HCL...G... SIL single port

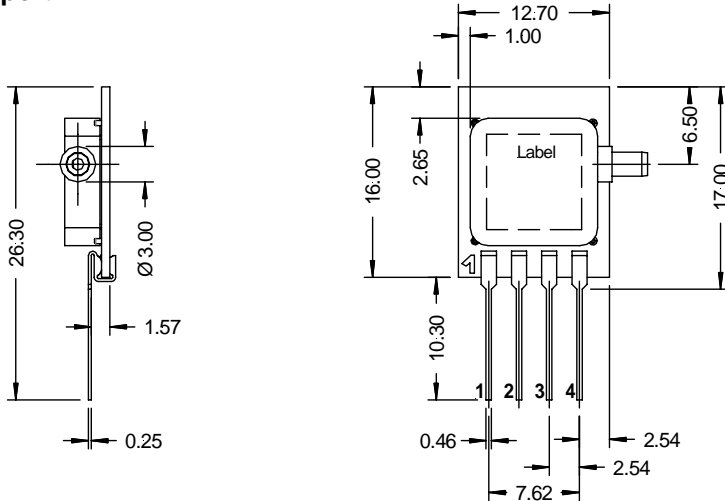

Pin	Connection
1	-Vs
2	+Vout
3	+Vs
4	-Vout

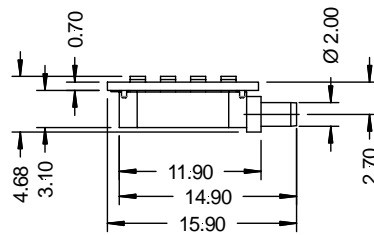
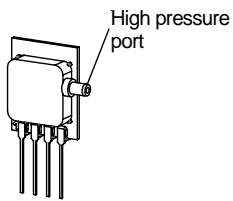

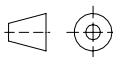

 first angle projection
 dimensions in mm

HCL...H... SMD single port

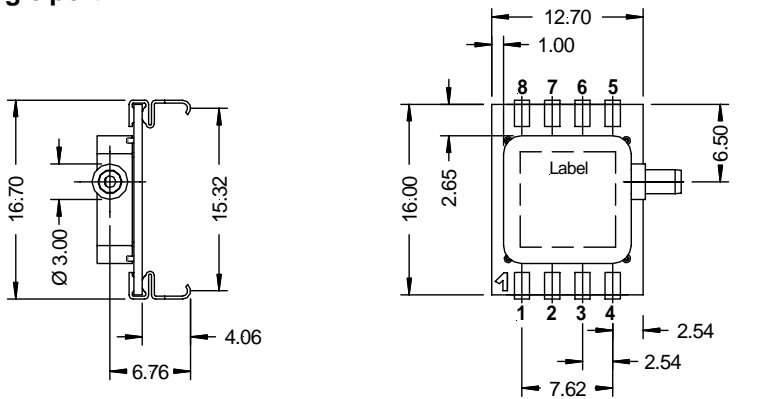

Pin	Connection
1	-Vs
2	+Vout
3	+Vs
4	-Vout
5	N / C
6	
7	
8	

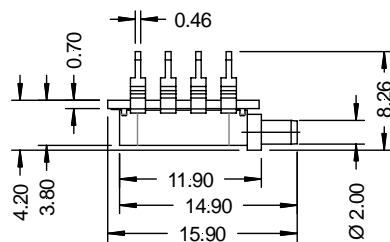
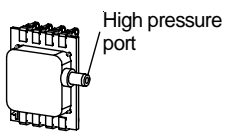

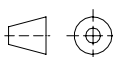

 first angle projection
 dimensions in mm

HCL Series

Miniature compensated low pressure sensors

HOUSING OPTIONS

Different housing options are available on request. Please contact First Sensor.

SIL dual port, opposite side (HCL...P...)

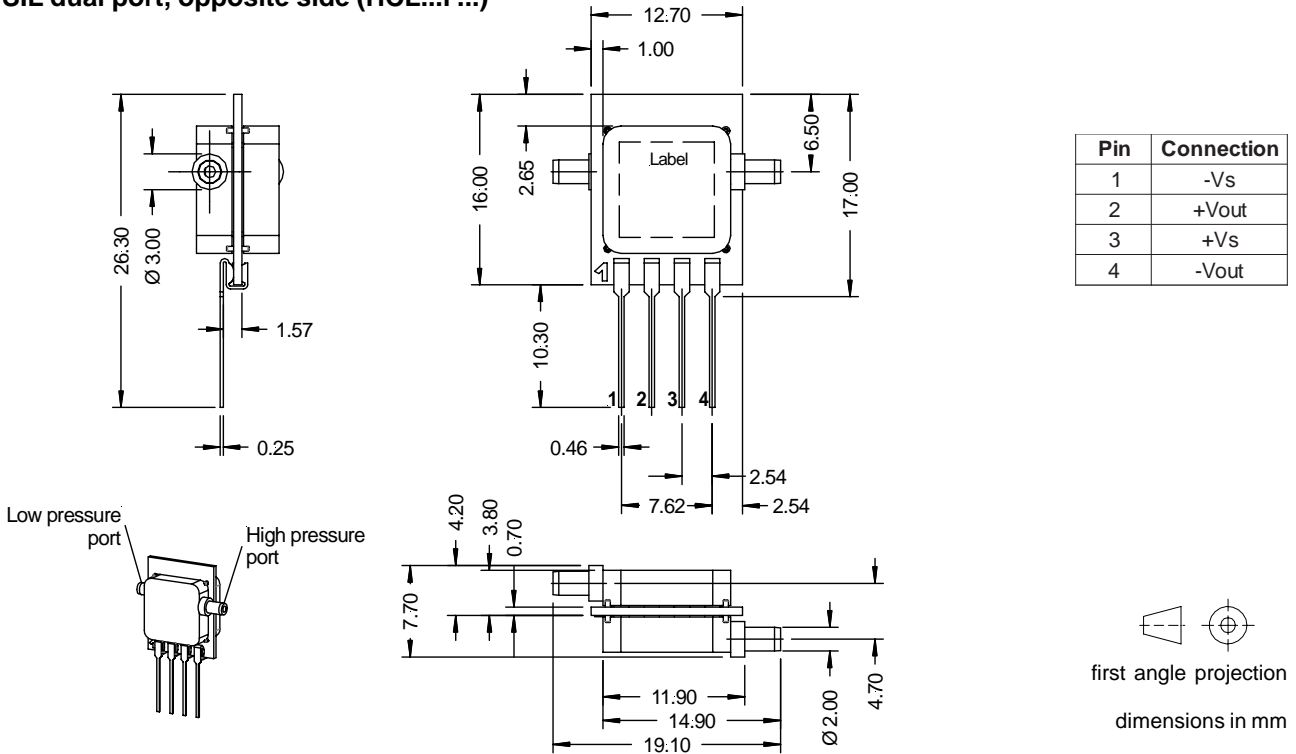

SMD dual port, opposite side (HCL...Q...)

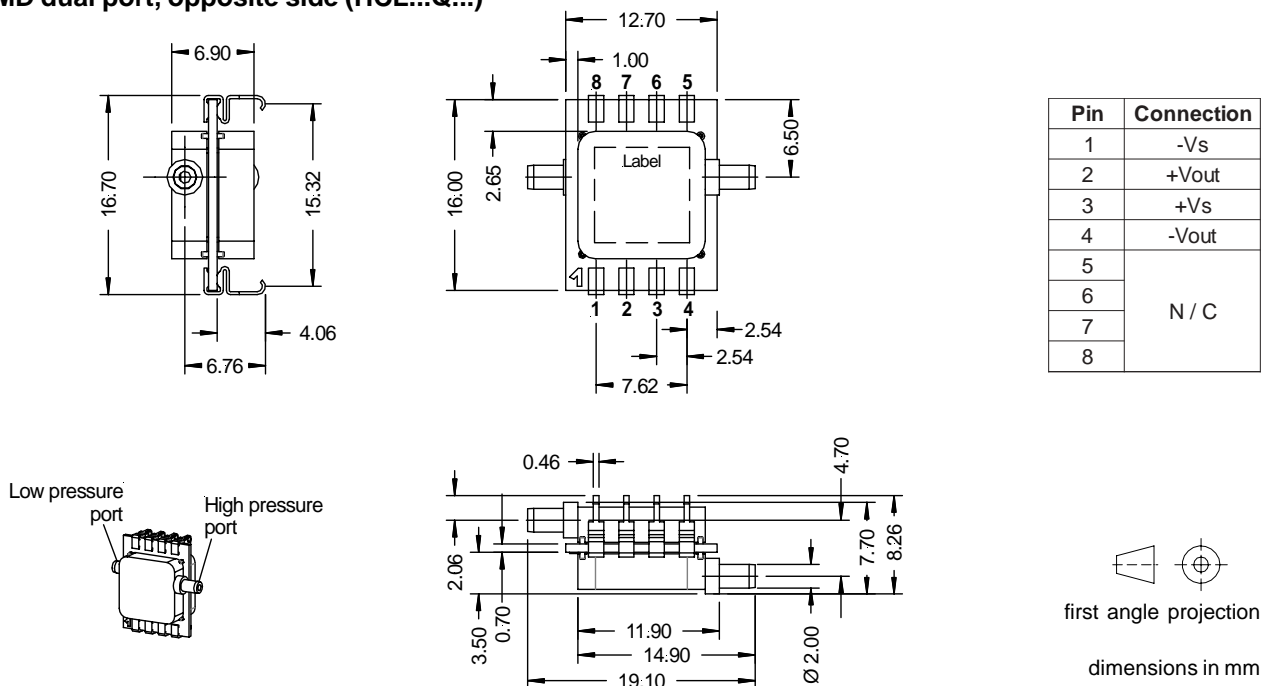

HCL Series

Miniature compensated low pressure sensors

HOUSING OPTIONS (cont.)

Different housing options are available on request. Please contact First Sensor.

SIL dual port, top side (HCL...T...)

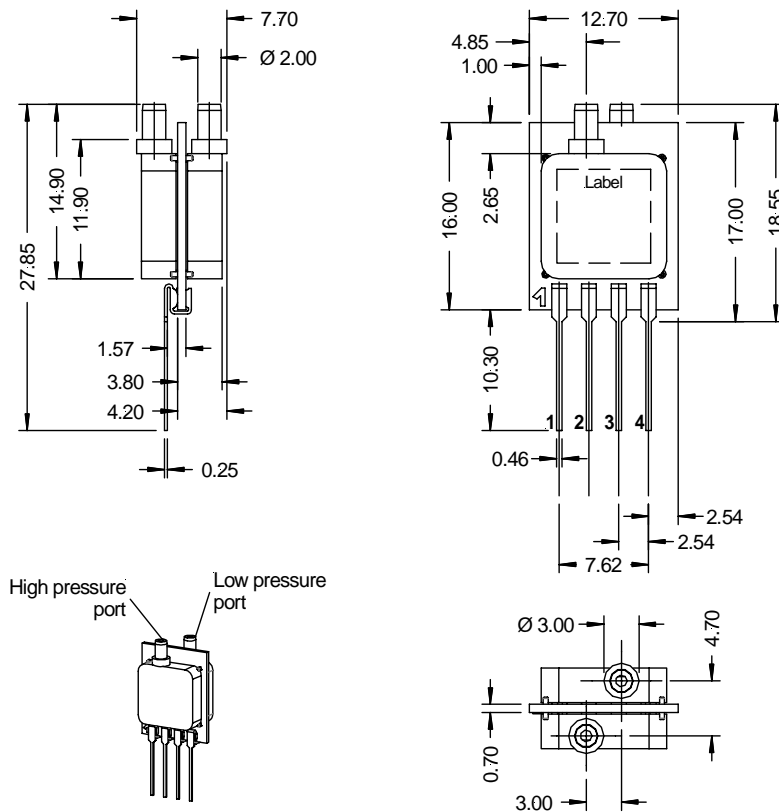

Pin	Connection
1	-Vs
2	+Vout
3	+Vs
4	-Vout

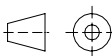

 first angle projection
 dimensions in mm

HCL Series

Miniature compensated low pressure sensors

HOUSING OPTIONS (cont.)

Different housing options are available on request. Please contact First Sensor.

Barbed pressure ports

(Available for all housing styles. Sample package shown: SMD dual port, same side)

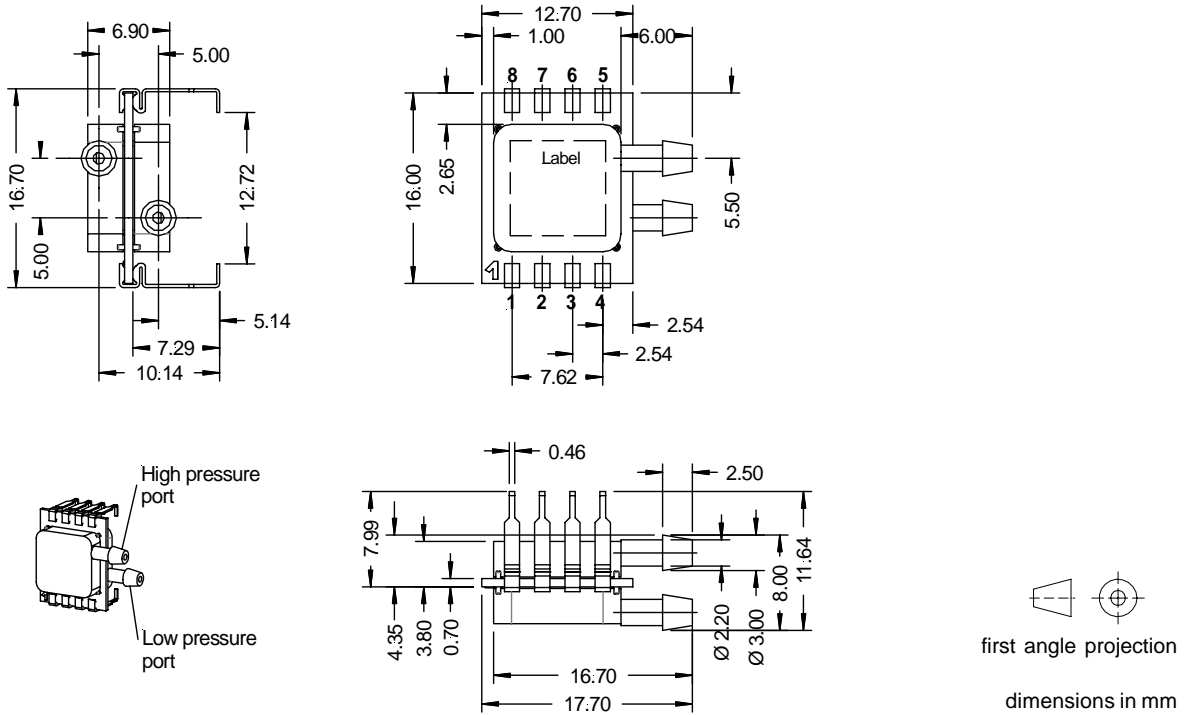

Dual Inline Packages (DIP)

(Available for all housing styles. Sample package shown: DIP dual port, same side)

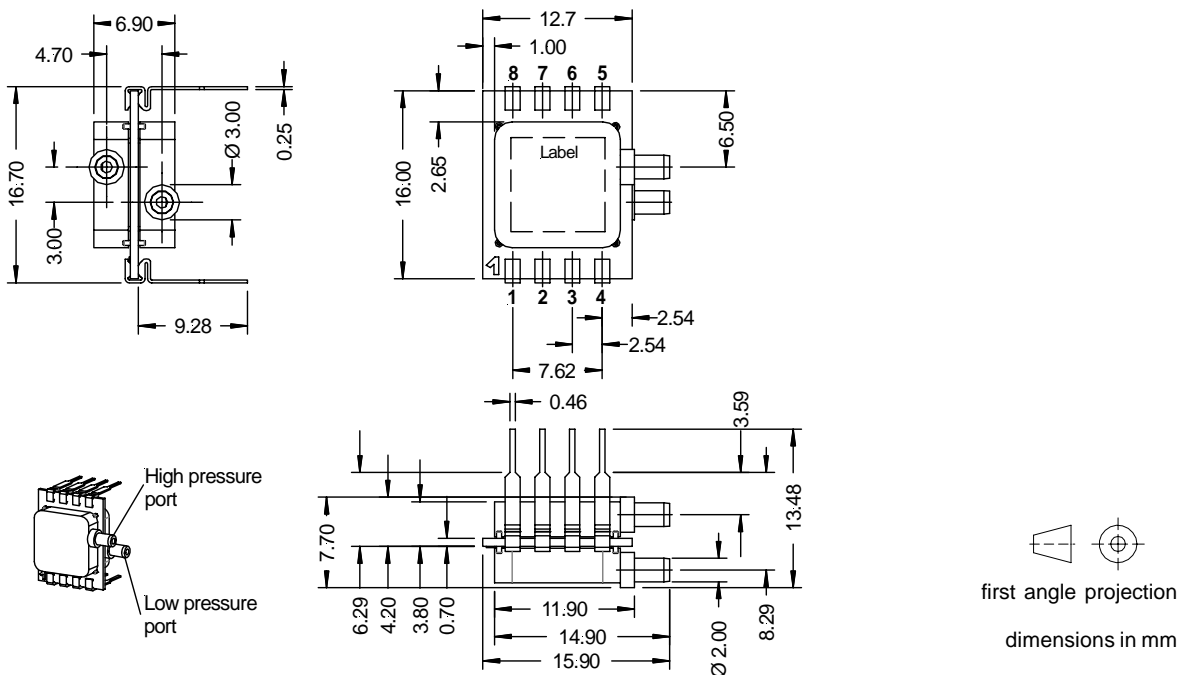

HCL Series

Miniature compensated low pressure sensors

ORDERING INFORMATION

Options	Series	Pressure range		Housing	
	HCL	0005	5 mbar	D	Diff SIL same side
		12X5	12.5 mbar	E	Diff SMD same side
		0025	25 mbar	G	Gage SIL
		0050	50 mbar	H	Gage SMD
		0075	75 mbar	(P)	Diff SIL opposite side
				(Q)	Diff SMD opposite side
				(T)	Diff SIL same top side
				Housings P, Q, T available on request. Please contact First Sensor.	
Example:	HCL	0005		D	

Custom specific pressure ranges and sensor modifications are widely available:

- barbed pressure ports
- Dual inline packages (DIP)
- ... etc.

Please contact First Sensor for further information.

First Sensor reserves the right to make changes to any products herein. First Sensor does not assume any liability arising out of the application or use of any product or circuit described herein, neither does it convey any license under its patent rights nor the rights of others.