



FSH10AR

Flow switch for G1", G2", G3" or G4" pipes



- General purpose switch for loads of up to 4A inductive
- 20 l/min turn on flow rate
- Automatic shut down on flow stop
- Adjustable time delay from 0 to 10 seconds for pump stop
- 1" BSP pipe connections for mounting

Technical Specification

Screw mount Material	Brass		
Enclosure material	Polyamide		
Enclosure rating	IP54		
Start up flow rate	Q. min	l/min	20
Max Pressure	P max	bar	10
Max Temperature	T max	°C	100
Pipe connections	BSP		1"
Pump stop delay range			0 - 10

Electrical Specification

Supply Voltage	Vac	24 or 240
Switching Voltage Max	Vac	250
Switching Power Max	kW	1
Switching Current Max	A	10 for resistive load 4A for motor load

Standard Parts

	On flow rate	Max Power	Max Load current
FSH10AR	20 l/min	750	4A

The FSH10AR can be used to control a pump or some other equipment or process via a relay output. If used in a pumped system, the device has to be fitted in the pipe after the pump.

It could be for controlling a circulating or centrifugal electric pump that is providing increased pressure or flow within water systems with storage tanks.

The FSH10 switches the output, once the flow rate through the pipe exceeds 20 l/min. When used to activate a pump, it can give an increased flow and pressure, dependant on the pump capacity.

The turn off time delay is adjustable between 0 and 10 seconds.

A flow of less than 20 l/min, whether due to a lack of supply (e.g. tank empty) or to a decrease in demand (e.g. tap closing), will turn the output off again.

Cynergy3 Components Ltd.
7 Cobham Road
Ferndown Industrial Estate
Wimborne, Dorset BH21 7PE
Telephone +44 (0) 1202 897969

Email: sales@cynergy3.com

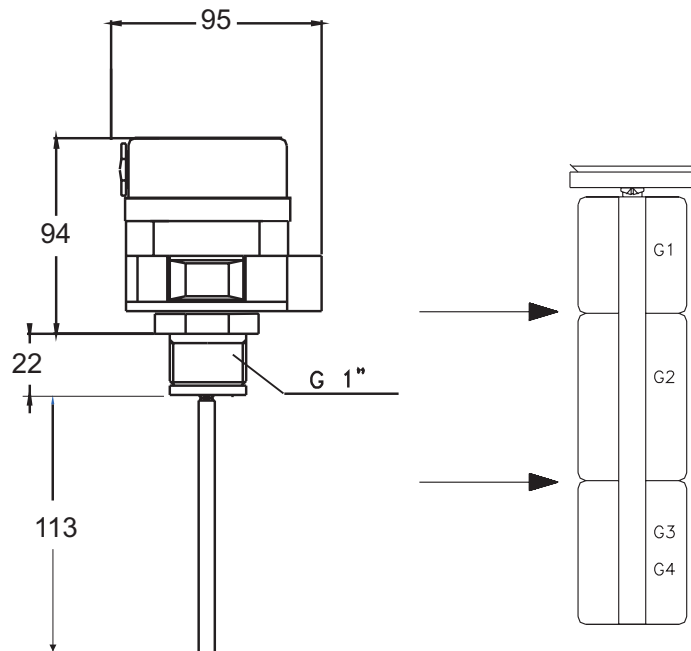



FSH10AR

Flow switch for G1", G2", G3" or G4" pipes

Installation information

The flow switch is designed to be used in a horizontal pipe with the switch mounted through a side entry. Pipe connection is G1" (1" BSP). The device relies on the flow of liquid working in opposition to the spring loaded paddle to operate the relay.

The liquid flow moves paddle within the pipe, when the flow increases beyond the minimum specified level. A magnet mounted on the head of the paddle closes a magnetic switch in the control circuit, so causing this to operate the output relay.

The output relay will remain energised for the time delay set, if the flow drops below the specified level and the paddle has returned to the rest position, and will then be de-energised.

The output relay will be energised for the time delay set, if the unit is disconnected then reconnected to the supply voltage or the test button is pushed.

The unit can operate on a supply voltage of either 24 or 240ac.

The output is a SPCO electromechanical relay with contacts rated to 10(4)A 250Vac.

There is a spare terminal connected to the 240Vac supply that can be used, if a 240Vac supply is being used, to link to the common contact of the relay, if a 240Vac output is required.

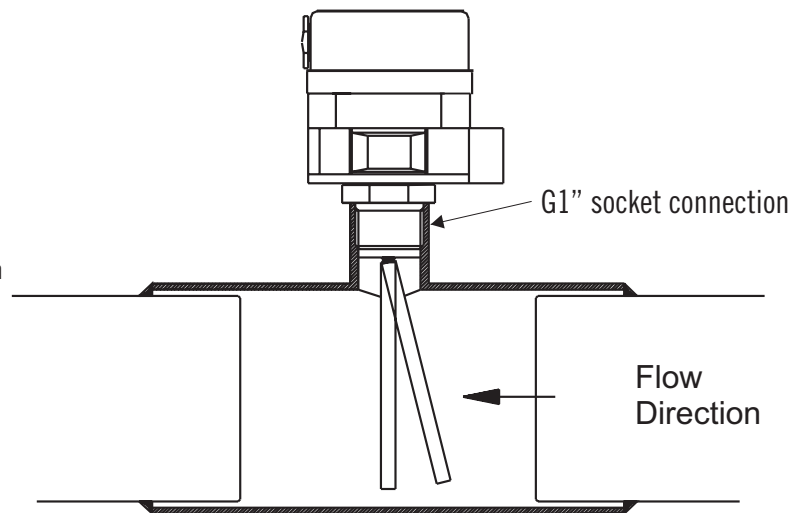

G1" - G4" pipe size

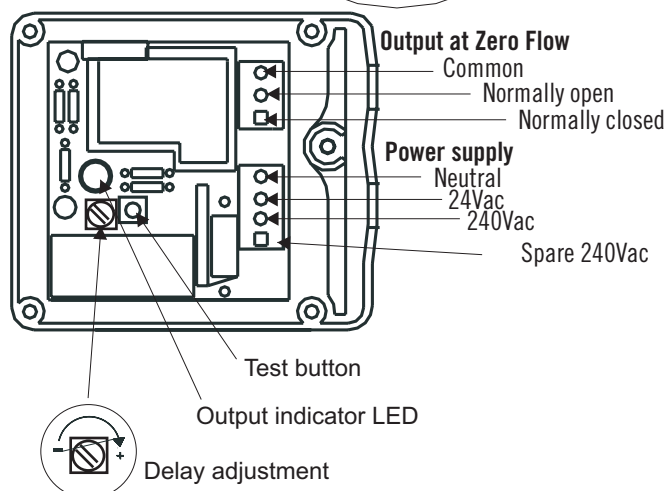
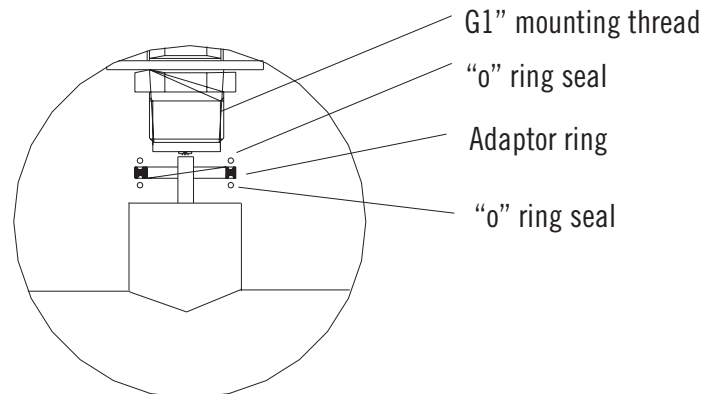

Cynergy3 Components Ltd.
7 Cobham Road
Ferndown Industrial Estate
Wimborne, Dorset BH21 7PE
Telephone +44 (0) 1202 897969

Email: sales@cynergy3.com

ISO9001 CERTIFIED

www.cynergy3.com