



Crimzon® ZLR16300

Z8® Low-Voltage ROM MCUs with Infrared Timers

Product Specification



**Maxim Integrated Products
120 San Gabriel Drive
Sunnyvale, CA 94086
United States**

**408-737-7600
www.maxim-ic.com**

Copyright © 2009 Maxim Integrated Products

Maxim cannot assume responsibility for use of any circuitry other than circuitry entirely embodied in a Maxim product. Maxim retains the right to make changes to its products or specifications to improve performance, reliability or manufacturability. All information in this document, including descriptions of features, functions, performance, technical specifications and availability, is subject to change without notice at any time. While the information furnished herein is held to be accurate and reliable, no responsibility will be assumed by Maxim for its use. Furthermore, the information contained herein does not convey to the purchaser of microelectronic devices any license under the patent right of any manufacturer.

Maxim is a registered trademark of Maxim Integrated Products, Inc.

All other products or service names used in this publication are for identification purposes only, and may be trademarks or registered trademarks of their respective companies. All other trademarks or registered trademarks mentioned herein are the property of their respective holders.

Z8 is a registered trademark of Zilog, Inc.

Crimzon is a registered trademark of Universal Electronics Inc.



Revision History

Each instance in the Revision History table reflects a change to this document from its previous revision. For more details, refer to the corresponding pages and appropriate links in the table below.

Date	Revision Level	Description	Page No
April 2009	19	Changed to Maxim product	All
February 2008	18	Updated the Ordering Information section.	85
January 2008	17	Updated the Ordering Information section.	85
August 2007	16	Updated the Disclaimer section and implemented style guide.	All
February 2007	15	Updated Low-Voltage Detection .	53
April 2006	14	Added pin P22 to the SMR block input, Figure 30 .	47
December 2005	13	Updated Input output port and Clock.	12, 47



Table of Contents

Architectural Overview	1
Features	1
Functional Block Diagram	3
Pin Description	5
Pin Functions	7
XTAL1 Crystal 1 (Time-Based Input)	7
XTAL2 Crystal 2 (Time-Based Output)	7
Input/Output Ports	7
Functional Description	14
Program Memory	14
RAM	15
Expanded Register File	16
Register File	19
Stack	20
Timers	20
Counter/Timer Functional Blocks	28
Input Circuit	28
Interrupts	39
Clock	42
Power Management	43
Power-On Reset	43
Port Configuration	44
Stop Mode Recovery	44
Watchdog Timer Mode	50
Low-Voltage Detection	53
Expanded Register File Control Registers (0D)	54
Expanded Register File Control Registers (0F)	60
Standard Control Registers	63
Electrical Characteristics	71
Absolute Maximum Ratings	71
Standard Test Conditions	72
DC Characteristics	72
AC Characteristics	74
Capacitance	76
Packaging	79
Ordering Information	85
Part Number Description	87
Index	88
Customer Support	92



Architectural Overview

Maxim's Crimzon® ZLR16300 MCU is a ROM-based member of the Crimzon ZLR16300 family of general-purpose microcontrollers. With 1 KB to 16 KB of Program Memory and 237 B of general-purpose RAM, Maxim's CMOS microcontrollers offer fast-executing, efficient use of memory, sophisticated interrupts, input/output (I/O) bit manipulation capabilities, automated pulse generation/reception, and internal key-scan pull-up transistors.

The Crimzon ZLR16300 architecture (see [Figure 1](#) on page 3 and [Figure 2](#) on page 4) is based on Maxim's 8-bit microcontroller core with an Expanded Register File allowing access to register-mapped peripherals, I/O circuits, and powerful counter/timer circuitry. The Z8® core offers a flexible I/O scheme, an efficient register and address space structure, and a number of ancillary features that are useful in many consumer, automotive, computer peripheral, and battery-operated hand-held applications.

There are three basic address spaces available to support a wide range of configurations:

1. Program Memory
2. Register File
3. Expanded Register File

The Register file is composed of 256 B of RAM. It includes three I/O port registers, 16 control and status registers, and 237 general-purpose registers. The Expanded Register file consists of two additional register groups (F and D).

To unburden the program from coping with such real-time problems like generating complex waveforms or receiving and demodulating complex waveform/pulses, the Crimzon ZLR16300 offers a new intelligent counter/timer architecture with 8-bit and 16-bit counter/timers (see [Figure 2](#) on page 4). Also included are a large number of user-selectable modes and two on-board comparators to process analog signals with separate reference voltages.

Features

[Table 1](#) lists the features of Crimzon ZLR16300 family.

Table 1. Crimzon ZLR16300 ROM MCU Features

Device	ROM (KB)	RAM* (Bytes)	I/O Lines	Voltage Range
Crimzon ZLR16300	1, 2, 4, 8, 16	237	24, 16	2.0–3.6 V

*General-purpose



The additional features include:

- Low power consumption—5 mW (typical)
- Three standby modes:
 - STOP—1.3 μ A (typical)
 - HALT—0.5 mA (typical)
 - Low-voltage reset
- Special architecture to automate both generation and reception of complex pulses or signals:
 - One programmable 8-bit counter/timer with two capture registers and two load registers
 - One programmable 16-bit counter/timer with one 16-bit capture register pair and one 16-bit load register pair
 - Programmable input glitch filter for pulse reception
- Six priority interrupts
 - Three external
 - Two assigned to counter/timers
 - One low-voltage detection interrupt
- Low-Voltage Detection and High-Voltage Detection Flags
- Programmable Watchdog Timer (WDT)
- Power-On Reset (POR)
- Two independent comparators with programmable interrupt polarity
- Selectable pull-up transistors on ports 0, 2, and 3
- Mask options
 - Port 0: 0–3 pull-ups
 - Port 0: 4–7 pull-ups
 - Port 2: 0–7 pull-ups
 - Port 3: 0–3 pull-ups
 - Watchdog Timer at Power-On Reset

Power connections use the conventional descriptions listed in [Table 2](#).

Table 2. Power Connections

Connection	Circuit	Device
Power	V _{CC}	V _{DD}
Ground	GND	V _{SS}



Functional Block Diagram

Figure 1 displays the Crimzon ZLR16300 MCU functional block diagram.

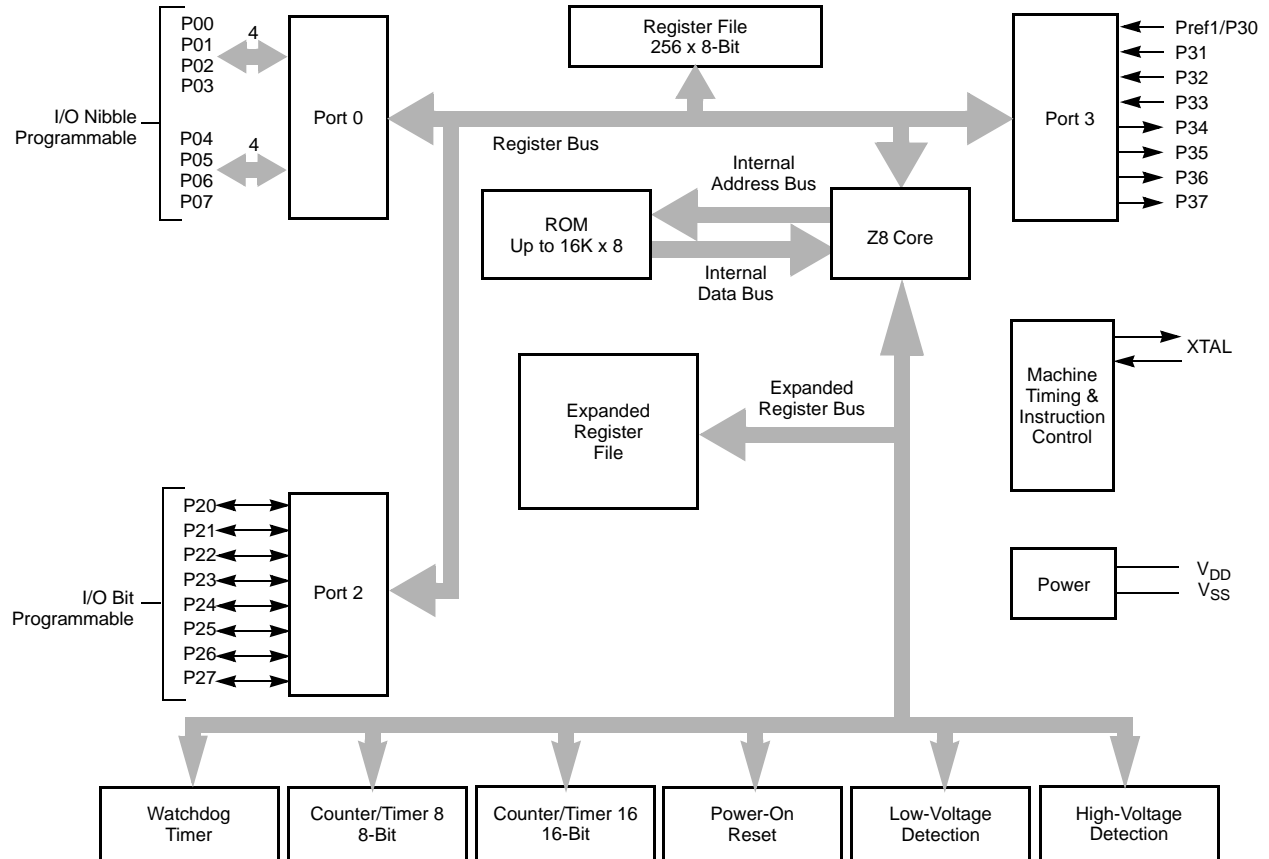

Note: Refer to the specific package for available pins.

Figure 1. Crimzon ZLR16300 MCU Functional Block Diagram

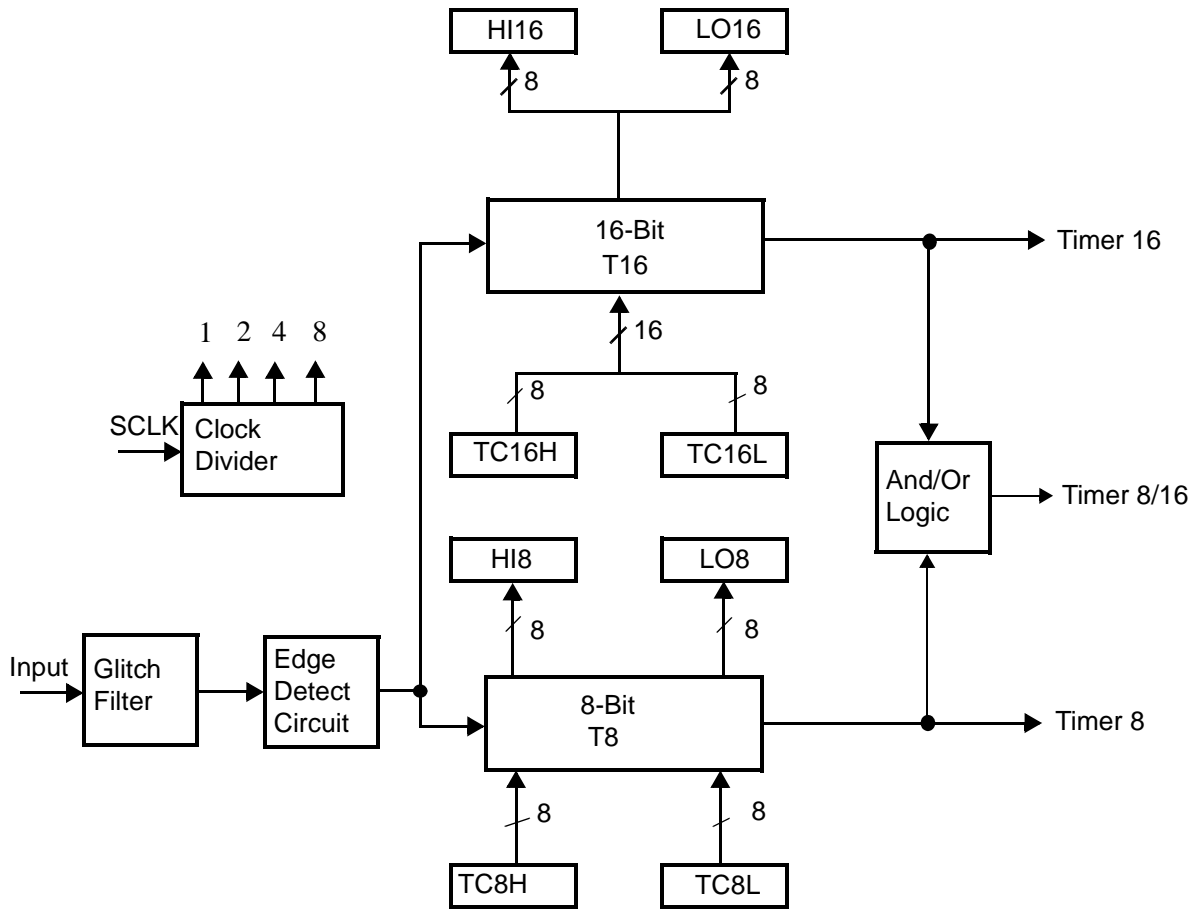

Figure 2. Counter/Timers Diagram



Pin Description

The pin configuration for the 20-pin DIP/SOIC/SSOP is displayed in Figure 3 and described in Table 3. The pin configuration for the 28-pin DIP/SOIC/SSOP are displayed in Figure 4 on page 6 and described in Table 4 on page 6.

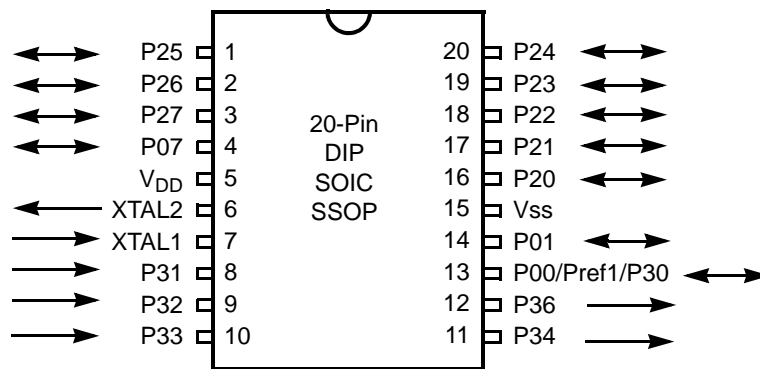

Figure 3. 20-Pin DIP/SOIC/SSOP Pin Configuration

Table 3. 20-Pin DIP/SOIC/SSOP Pin Identification

Pin No	Symbol	Function	Direction
1–3	P25–P27	Port 2, Bits 5,6,7	Input/Output
4	P07	Port 0, Bit 7	Input/Output
5	V _{DD}	Power Supply	
6	XTAL2	Crystal Oscillator Clock	Output
7	XTAL1	Crystal Oscillator Clock	Input
8–10	P31–P33	Port 3, Bits 1,2,3	Input
11,12	P34, P36	Port 3, Bits 4,6	Output
13	P00/Pref1/P30	Port 0, Bit 0/Analog reference input Port 3, Bit 0	Input/Output for P00 Input for Pref1/P30
14	P01	Port 0, Bit 1	Input/Output
15	V _{SS}	Ground	
16–20	P20–P24	Port 2, Bits 0,1,2,3,4	Input/Output

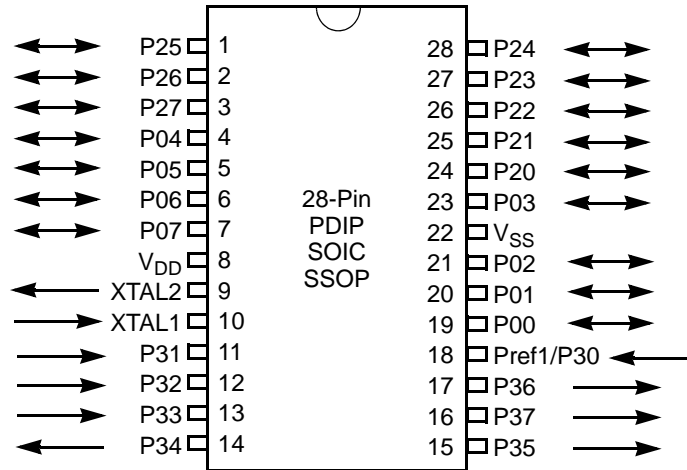

Figure 4. 28-Pin DIP/SOIC/SSOP Pin Configuration

Table 4. 28-Pin DIP/SOIC/SSOP Pin Identification

Pin No	Symbol	Function	Direction
1-3	P25-P27	Port 2, Bits 5,6,7	Input/Output
4-7	P04-P07	Port 0, Bits 4,5,6,7	Input/Output
8	V _{DD}	Power supply	
9	XTAL2	Crystal, oscillator clock	Output
10	XTAL1	Crystal, oscillator clock	Input
11-13	P31-P33	Port 3, Bits 1,2,3	Input
14	P34	Port 3, Bit 4	Output
15	P35	Port 3, Bit 5	Output
16	P37	Port 3, Bit 7	Output
17	P36	Port 3, Bit 6	Output
18	Pref1	Analog ref input; connect to V _{CC} if not used Port 3 Bit 0	Input
19-21	P00-P02	Port 0, Bits 0,1,2	Input/Output
22	V _{SS}	Ground	
23	P03	Port 0, Bit 3	Input/Output
24-28	P20-P24	Port 2, Bits 0-4	Input/Output



Pin Functions

XTAL1 Crystal 1 (Time-Based Input)

This pin connects a parallel-resonant crystal or ceramic resonator to the on-chip oscillator input. Additionally, an external single-phase clock can be connected to the on-chip oscillator input.

XTAL2 Crystal 2 (Time-Based Output)

This pin connects a parallel-resonant crystal or ceramic resonator to the on-chip oscillator output.

Input/Output Ports



Caution: *The CMOS input buffer for each ports 0, 1, or 2 pin is always connected to the pin, even when the pin is configured as an output. If the pin is configured as an open-drain output and no external signal is applied, a High output state causes the CMOS input buffer to float. This leads to excessive leakage current of more than 100 μ A. To prevent this leakage, connect the pin to an external signal with a defined logic level or ensure its output state is Low, especially during STOP mode.*

Internal pull-ups are disabled on any given pin or group of port pins when programmed into output mode.

Port 0, 1, and 2 have both input and output capability. The input logic is always present no matter whether the port is configured as input or output. While performing a READ instruction, the MCU reads the actual value at the input logic but not from the output buffer. In addition, the instructions of OR, AND, and XOR have the Read-Modify-Write sequence. The MCU first reads the port, modifies the value, and loads back to the port.

Precaution must be taken if the port is configured as open-drain output or if the port is driving any circuit that makes the voltage different from the desired output logic. For example, pins P00–P07 are not connected to anything else. If it is configured as open-drain output with output logic as ONE, it is a floating port and reads back as ZERO. The following instruction sets P00-P07 all Low.

```
AND P0, #%F0
```

Port 0 (P07–P00)

Port 0 is an 8-bit, bidirectional, and CMOS-compatible port. These eight I/O lines are configured under software control as a nibble I/O port. The output drivers are push-pull or open-drain controlled by bit D2 in the PCON register.

If one or both nibbles are required for I/O operation, they must be configured by writing to the Port 0 mode register. After a hardware reset, Port 0 is configured (see Figure 5) as an input port.

An optional pull-up transistor is available as a mask option on all Port 0 bits with nibble select.

► **Note:** *The Port 0 direction is reset to be input following an Stop Mode Recovery.*

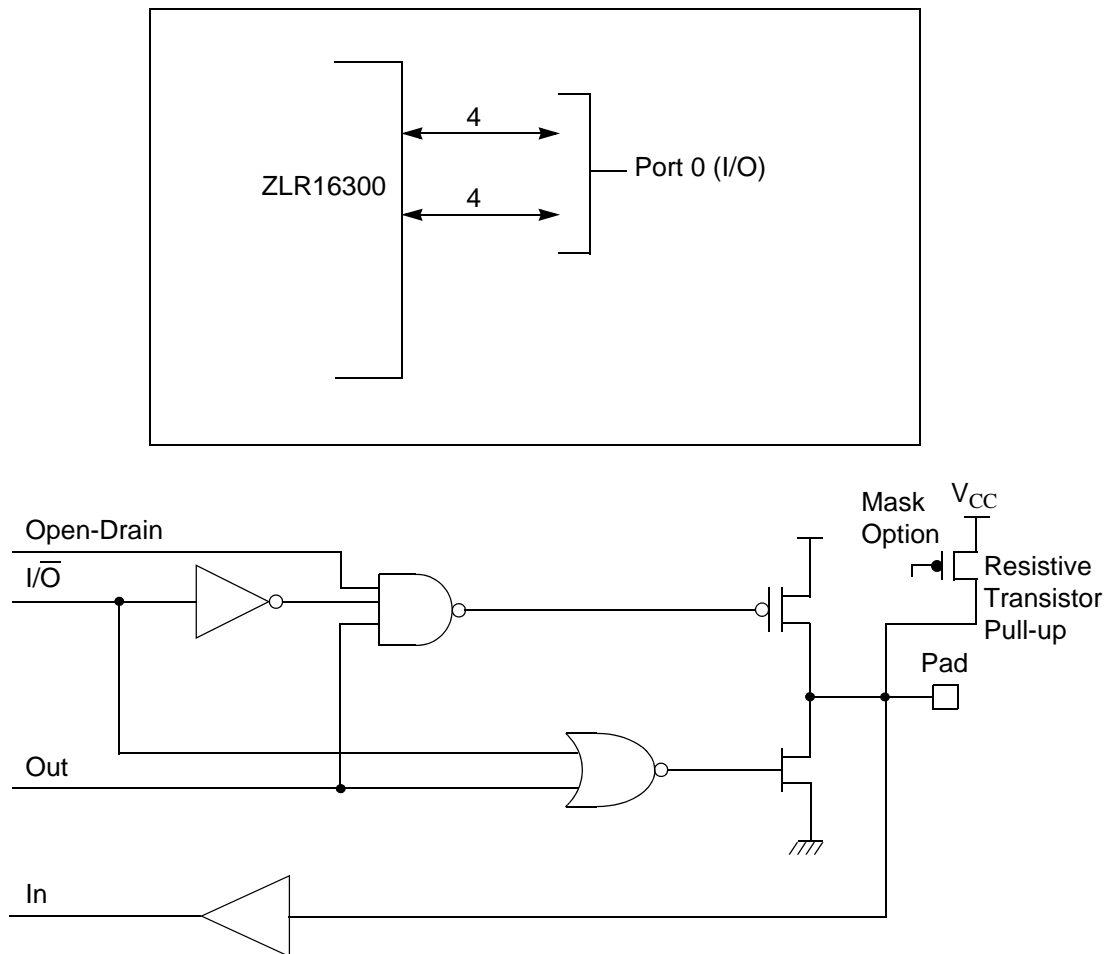

Figure 5. Port 0 Configuration



Port 2 (P27–P20)

Port 2 is an 8-bit, bidirectional, and CMOS-compatible I/O port (see Figure 6). These eight I/O lines are independently configured under software control as inputs or outputs. Port 2 is always available for I/O operation. A mask option connects eight pull-up transistors on this port. Bits programmed as outputs are globally programmed as either push-pull or open-drain. The POR resets with the eight bits of Port 2 configured as inputs.

Port 2 also has an 8-bit input OR and AND gate which can be used to wake up the part. P20 is programmed to access the edge-detection circuitry in DEMODULATION mode.

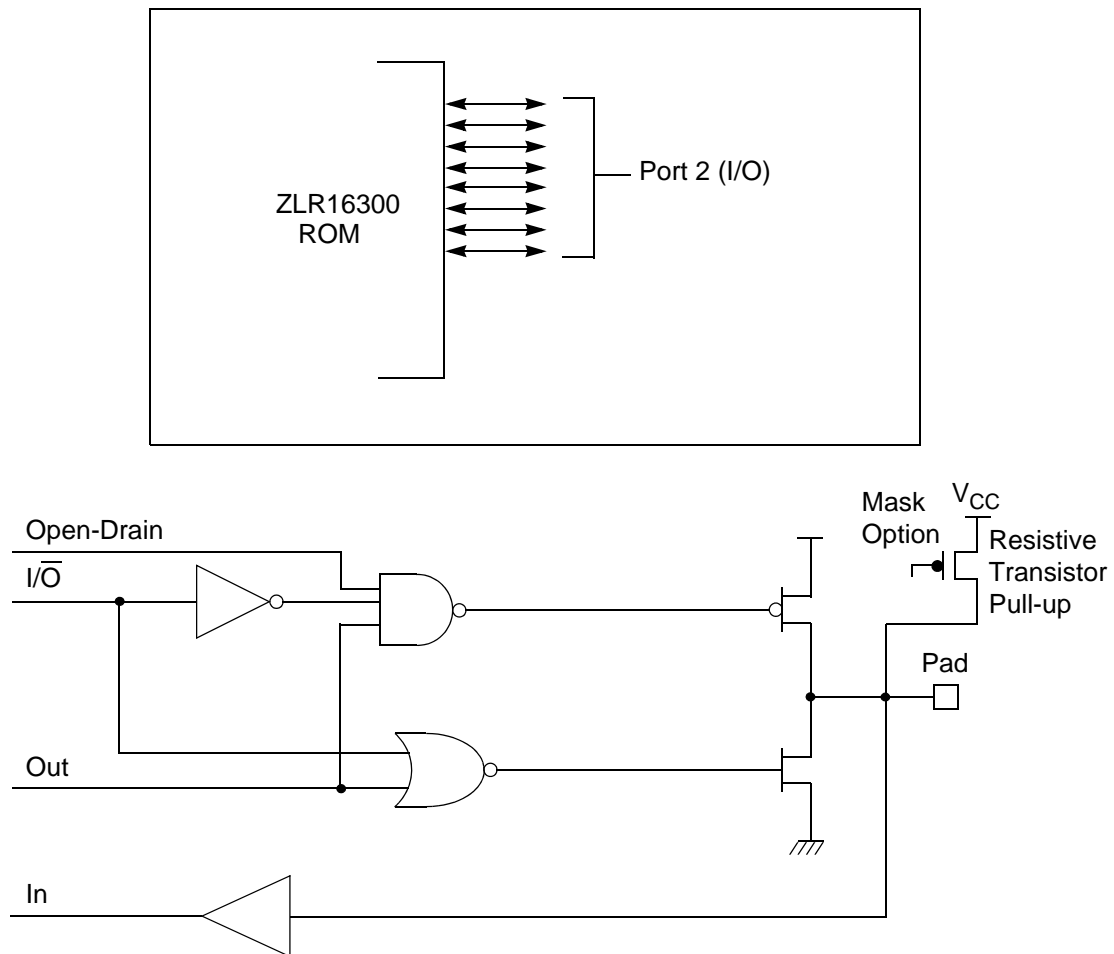

Figure 6. Port 2 Configuration



Port 3 (P37–P30)

Port 3 is an 8-bit, CMOS-compatible fixed I/O port (see Figure 7). Port 3 consists of four fixed input (P33–P30) and four fixed output (P37–P34), which are configured under software control for interrupt and as output from the counter/timers. P30, P31, P32, and P33 are standard CMOS inputs; P34, P35, P36, and P37 are push-pull outputs.

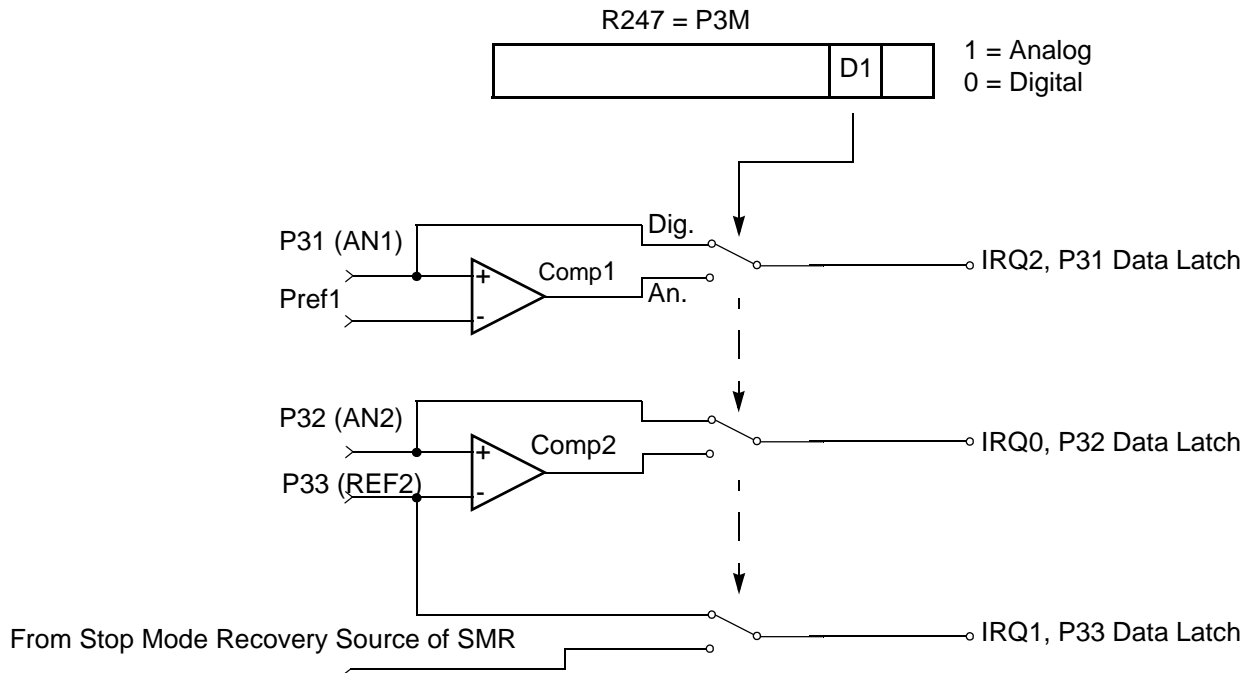
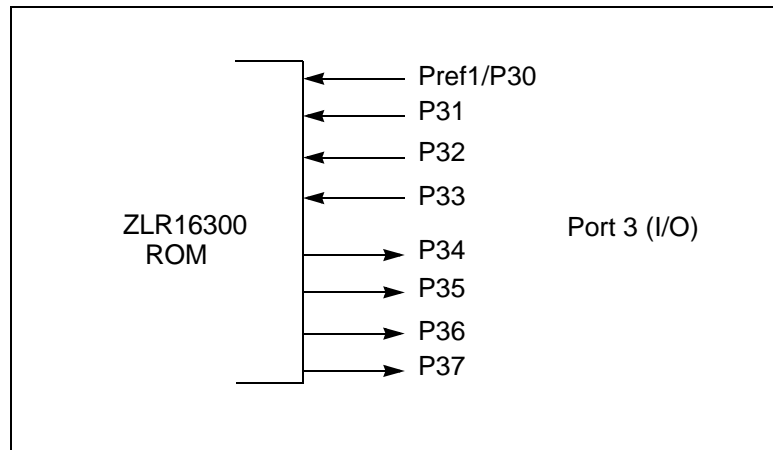

Figure 7. Port 3 Configuration



Two on-board comparators process analog signals on P31 and P32, with reference to the voltage on Pref1 and P33. The analog function is enabled by programming the Port 3 Mode Register (bit 1). P31 and P32 are programmable as rising, falling, or both edge triggered interrupts (IRQ register bits 6 and 7). Pref1 and P33 are the comparator reference voltage inputs. Access to the Counter Timer edge-detection circuit is through P31 or P20 (see [T8 and T16 Common Functions—CTR1\(0D\)01h](#) on page 23). Other edge detect and IRQ modes are described in [Table 5](#).

► **Note:** *Comparators are powered down by entering STOP mode. For P31–P33 to be used in a SMR source, these inputs must be placed into DIGITAL mode.*

Table 5. Port 3 Pin Function Summary

Pin	I/O	Counter/Timers	Comparator	Interrupt
Pref1/P30	IN		RF1	
P31	IN	IN	AN1	IRQ2
P32	IN		AN2	IRQ0
P33	IN		RF2	IRQ1
P34	OUT	T8	AO1	
P35	OUT	T16		
P36	OUT	T8/16		
P37	OUT		AO2	
P20	I/O	IN		

Port 3 also provides output for each of the counter/timers and the AND/OR Logic (see [Figure 8](#)). Control is performed by programming bits D5–D4 of CTR1, bit 0 of CTR0, and bit 0 of CTR2.

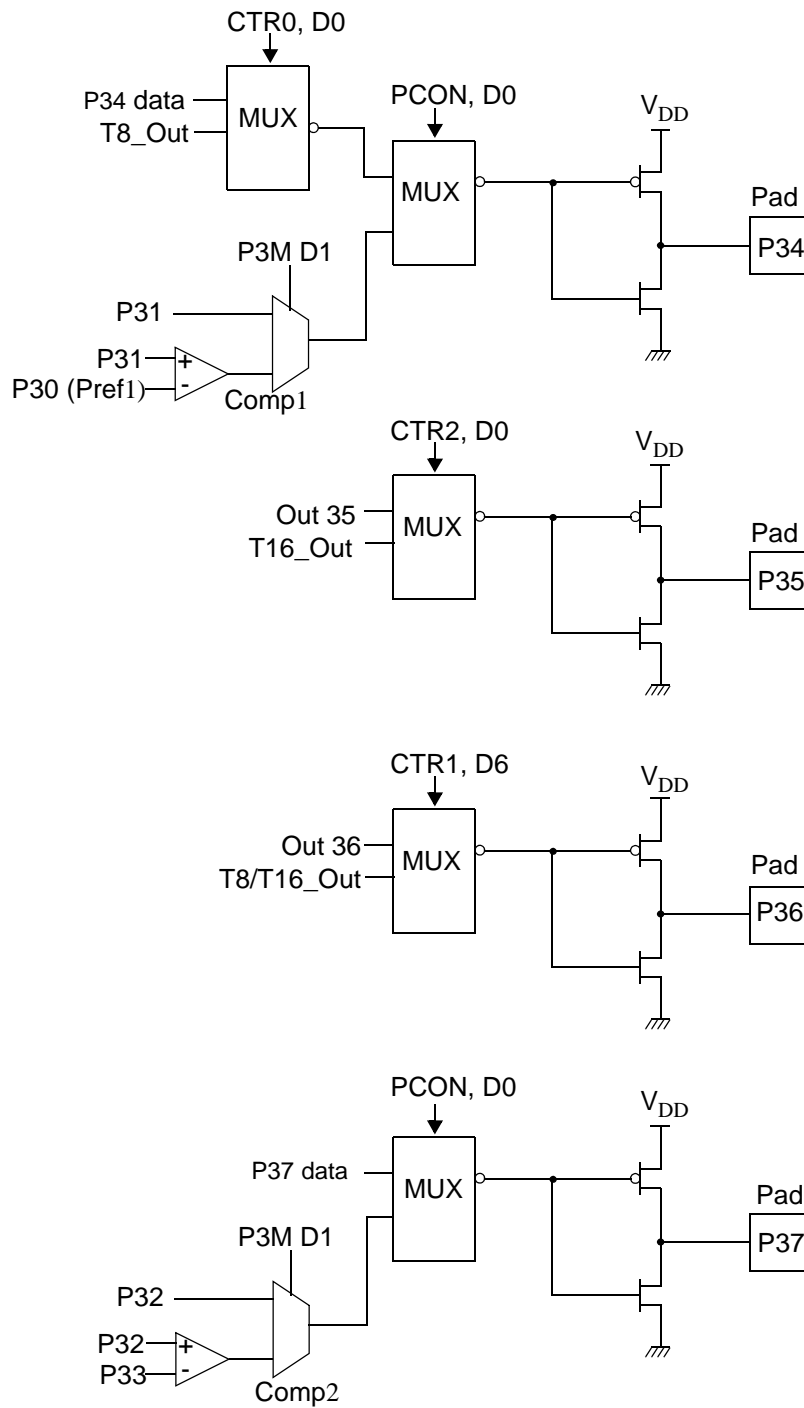

Figure 8. Port 3 Counter/Timer Output Configuration



Comparator Inputs

In ANALOG mode, P31 and P32 have a comparator front end. The comparator reference is supplied to P33 and P_{REF1}. In this mode, the P33 internal data latch and its corresponding IRQ1 are diverted to the SMR sources (excluding P31, P32, and P33) as displayed in Figure 7 on page 10. In DIGITAL mode, P33 is used as D3 of the Port 3 input register, which then generates IRQ1.

- **Note:** *Comparators are powered down by entering STOP mode. For P31–P33 to be used in a Stop Mode Recovery source, these inputs must be placed into DIGITAL mode.*

Comparator Outputs

These channels are programmed to be output on P34 and P37 through the PCON register.



Functional Description

The Crimzon ZLR16300 family of devices incorporate special functions to enhance the functionality of Z8[®] in consumer and battery-operated applications.

Program Memory

These devices address from 1 KB to 16 KB of Program Memory. The first 12 bytes are reserved for interrupt vectors. These locations contain the six 16-bit vectors that correspond to the six available interrupts. See [Figure 9](#) on page 15.



RAM

The Crimzon ZLR16300 product family features 237 bytes of RAM.

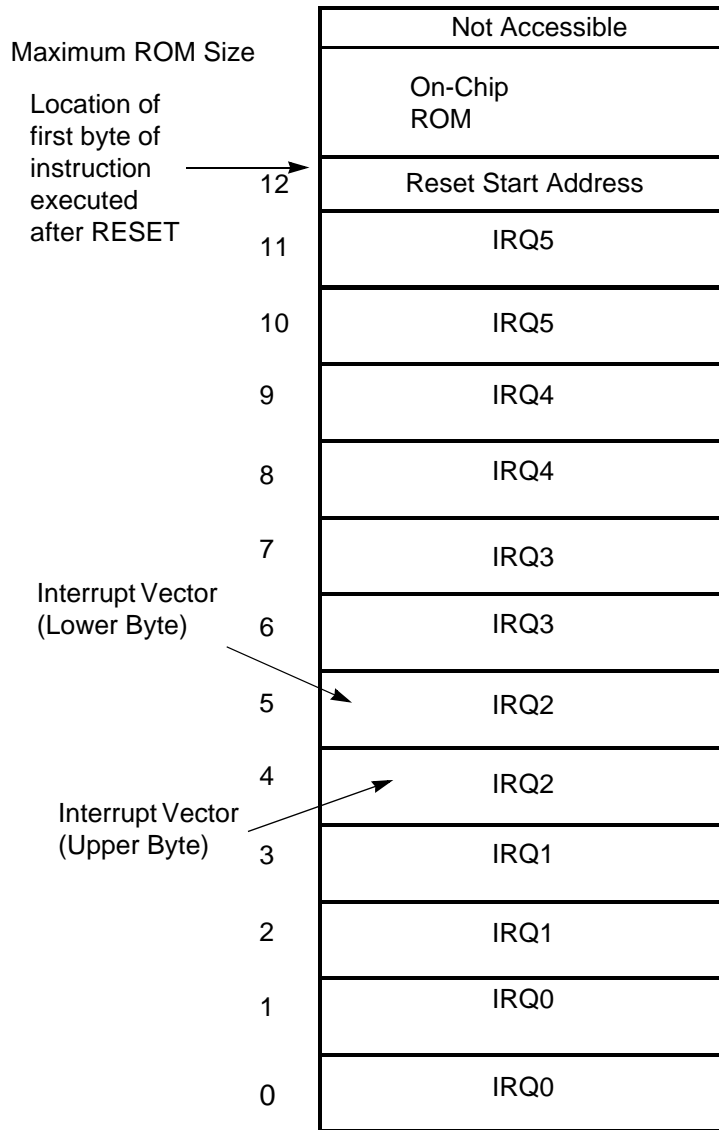

Figure 9. Program Memory Map



Expanded Register File

The register file has been expanded to allow for additional system control registers and for mapping additional peripheral devices into the register address area. The Z8 register address space (0 through 15 (0Fh)) has been implemented as 16 banks, with 16 registers per bank. These register banks are known as the ERF (Expanded Register File). Bits 7–4 of register RP select the working register group. Bits 3–0 of register RP select the expanded register file bank.

- **Note:** *An expanded register bank is also referred to as an expanded register group (see [Figure 10](#) on page 17).*

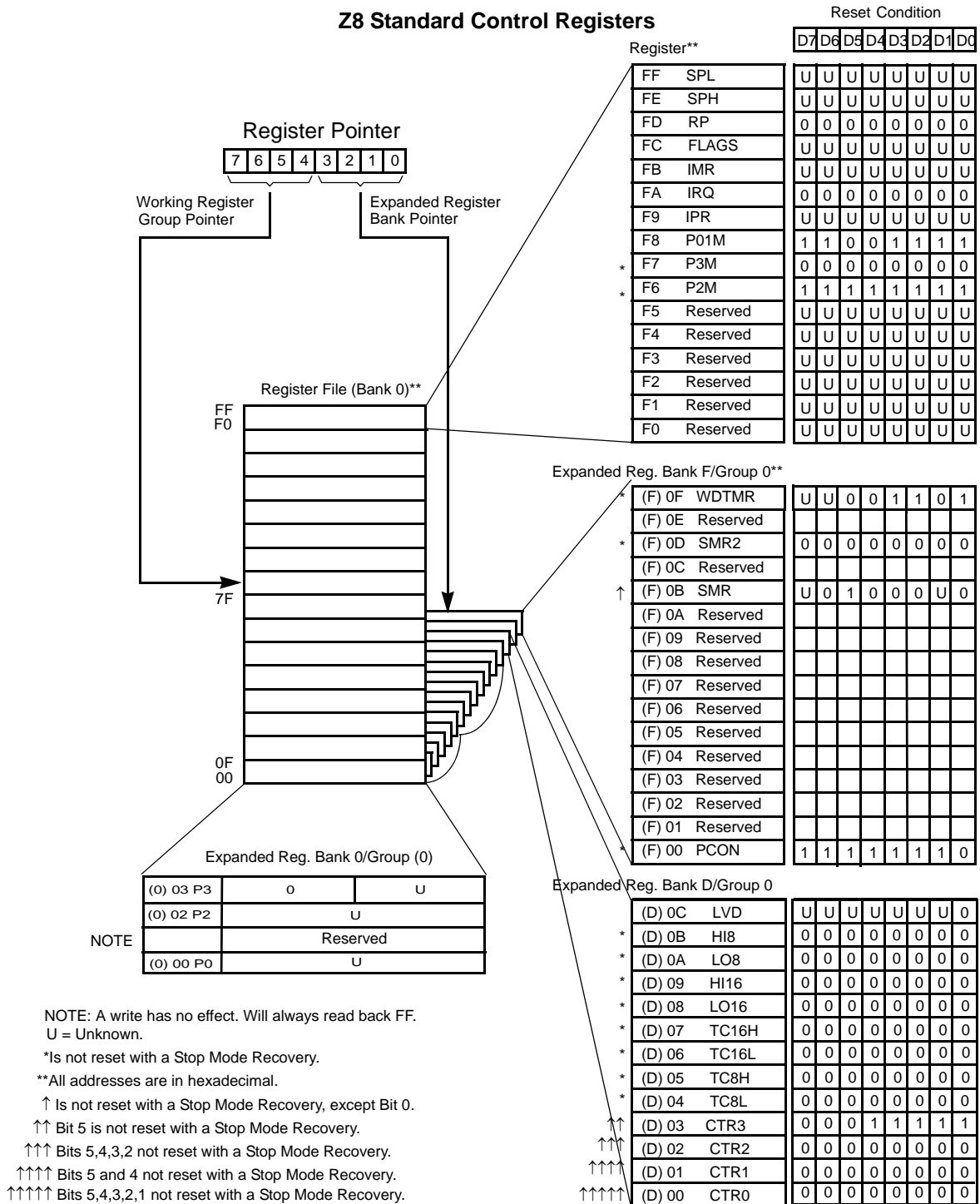

Figure 10. Expanded Register File Architecture



The upper nibble of the register pointer (see Figure 11) selects which working register group, of 16 bytes in the register file, is accessed out of the possible 256. The lower nibble selects the expanded register file bank and in the case of the Crimzon ZLR16300 family, banks 0, F, and D are implemented. A 0h in the lower nibble allows the normal register file (bank 0) to be addressed. Any other value from 1h to Fh exchanges the lower 16 registers to the selected expanded register bank.

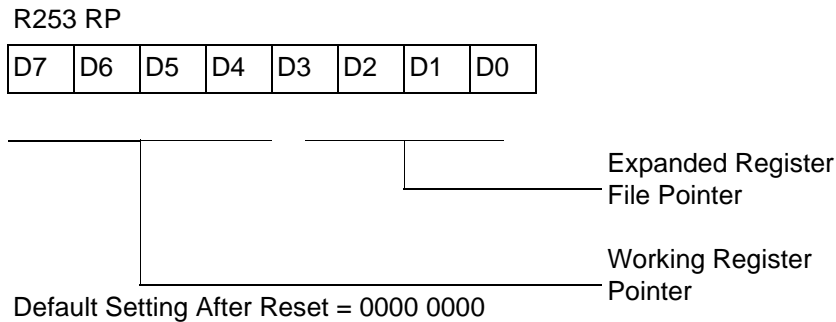

Figure 11. Register Pointer

Example: (See Figure 10 on page 17)

R253 RP = 00h
R0 = Port 0
R2 = Port 2
R3 = Port 3

But if:

R253 RP = 0Dh
R0 = CTR0
R1 = CTR1
R2 = CTR2
R3 = CTR3

The counter/timers are mapped into ERF group D. Access is easily performed using the following:

```
LD                RP, #0Dh                ;Select ERF D
                                                for access to
                                                bank D
                                                ;(working
                                                register group
                                                0)
LD                R0, #xx                ;load CTR0
```



```

LD          1, #xx          ;load CTR1
LD          R1, 2           ;CTR2→CTR1

LD          RP, #0Dh        ;Select ERF D
                                for access to
                                bank D
                                ; (working
                                register group
                                0)

LD          RP, #7Dh        ;Select
                                expanded
                                register bank D
                                and working
                                ;register group
                                7 of bank 0 for
                                access.

LD          71h, 2

;CTRL2→register
71h
LD          R1, 2           ;CTRL2→register 71h
;CTRL2→register 71h

```

Register File

The Register file (bank 0) consists of three I/O port registers, 237 general-purpose registers, 16 control and status registers (R0, R2, R3, R4–R239, and R240–R255, respectively), and two expanded register Banks D (see [Table 6](#) on page 22) and F. Instructions can access registers directly or indirectly through an 8-bit address field, thereby allowing a short, 4-bit register address to use the Register Pointer (see [Figure 12](#) on page 20). In the 4-bit mode, the register file is divided into 16 working register groups, each occupying 16 continuous locations. The Register Pointer addresses the starting location of the active working register group.

- **Note:** *Register address E0h–EFh can be accessed only through working registers and indirect addressing modes.*

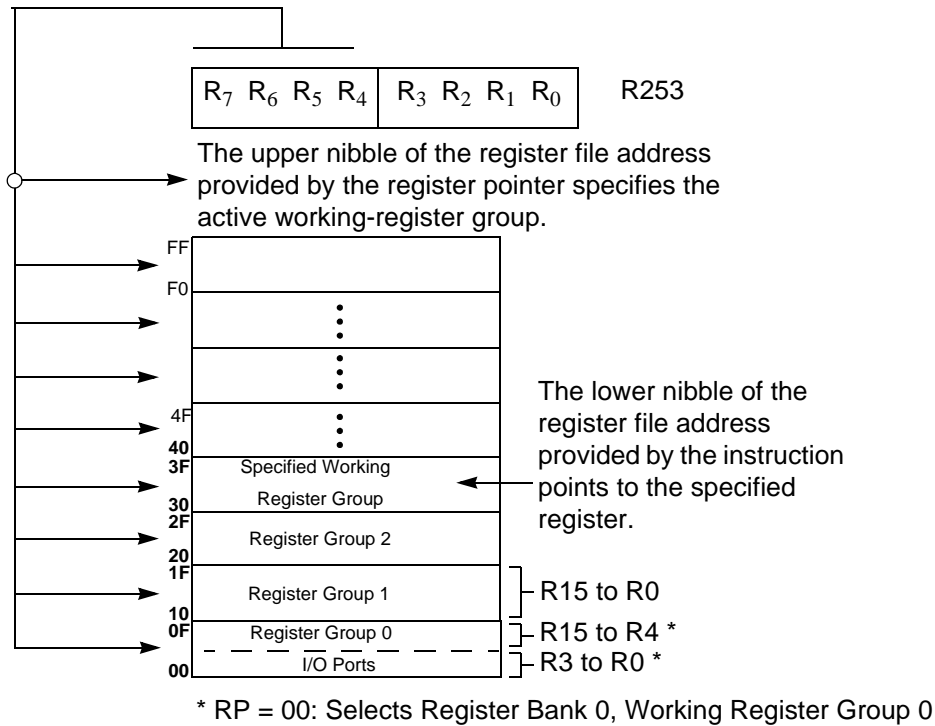

Figure 12. Register Pointer—Detail

Stack

The internal register file is used for the stack. An 8-bit Stack Pointer SPL (R255) is used for the internal stack that resides in the general-purpose registers (R4–R239). SPH (R254) is used as a general-purpose register.

Timers

T8_Capture_HI—HI8(0D)0Bh

This register stores the captured data from the output of the 8-bit Counter/Timer0. Typically, this register holds the number of counts when the input signal is 1.

Field	Bit Position	Description
T8_Capture_HI	[7:0]	R/W Captured Data—No Effect



T8_Capture_LO—L08(0D)0Ah

This register holds the captured data from the output of the 8-bit Counter/Timer0. Typically, this register holds the number of counts when the input signal is 0.

Field	Bit Position	Description
T8_Capture_LO	[7:0]	R/W Captured Data—No Effect

T16_Capture_HI—HI16(0D)09h

This register holds the captured data from the output of the 16-bit Counter/Timer16. This register holds the MS-Byte of the data.

Field	Bit Position	Description
T16_Capture_HI	[7:0]	R/W Captured Data—No Effect

T16_Capture_LO—L016(0D)08h

This register holds the captured data from the output of the 16-bit Counter/Timer16. This register holds the LS-Byte of the data.

Field	Bit Position	Description
T16_Capture_LO	[7:0]	R/W Captured Data—No Effect

Counter/Timer2 MS-Byte Hold Register—TC16H(0D)07h

Field	Bit Position	Description
T16_Data_HI	[7:0]	R/W Data

Counter/Timer2 LS-Byte Hold Register—TC16L(0D)06h

Field	Bit Position	Description
T16_Data_LO	[7:0]	R/W Data



Counter/Timer8 High Hold Register—TC8H0(D)05h

Field	Bit Position	Description
T8_Level_HI	[7:0]	R/W Data

Counter/Timer8 Low Hold Register—TC8L(0D)04h

Field	Bit Position	Description
T8_Level_LO	[7:0]	R/W Data

CTR0 Counter/Timer8 Control Register—CTR0(0D)00h

Table 6 lists and briefly describes the fields for this register.

Table 6. CTR0(0D)00h Counter/Timer8 Control Register

Field	Bit Position		Value	Description
T8_Enable	7-----	R/W	0*	Counter Disabled
			1	Counter Enabled
			0	Stop Counter
			1	Enable Counter
Single/Modulo-N	-6-----	R/W	0*	Modulo-N
			1	Single-Pass
Time_Out	--5-----	R/W	0**	No Counter Time-Out
			1	Counter Time-Out Occurred
			0	No Effect
			1	Reset Flag to 0
T8_Clock	---43---	R/W	0 0**	SCLK
			0 1	SCLK/2
			1 0	SCLK/4
			1 1	SCLK/8
Capture_INT_Mask	----2--	R/W	0**	Disable Data Capture Interrupt
			1	Enable Data Capture Interrupt
Counter_INT_Mask	-----1-	R/W	0**	Disable Time-Out Interrupt
			1	Enable Time-Out Interrupt
P34_Out	-----0	R/W	0*	P34 as Port Output
			1	T8 Output on P34

*Indicates the value at Power-On Reset.

**Indicates the value upon Power-On Reset. Not reset with a Stop Mode Recovery.



T8 Enable

This field enables T8 when set to 1.

Single/Modulo-N

When set to 0 (MODULO-N), the counter reloads the initial value when the terminal count is reached. When set to 1 (Single-Pass), the counter stops when the terminal count is reached.

Timeout

This bit is set when T8 times out (terminal count reached). To reset this bit, write a 1 to its location.



Caution: *Writing a 1 is the only way to reset the Terminal Count status condition. Reset this bit before using/enabling the counter/timers.*

The first clock of T8 might not have complete clock width and can occur any time when enabled.



Note: *Ensure to manipulate CTR0, bit 5 and CTR1, bits 0 and 1 (DEMODULATION mode) while using the OR or AND commands. These instructions use a Read-Modify-Write sequence in which the current status from the CTR0 and CTR1 registers is ORed or ANDed with the designated value and then written back into the registers.*

T8 Clock

These bits define the frequency of the input signal to T8.

Capture_INT_Mask

Set this bit to allow an interrupt when data is captured into either LO8 or HI8 upon a positive or negative edge detection in CAPTURE Mode.

Counter_INT_Mask

Set this bit to allow an interrupt when T8 has a timeout.

P34_Out

This bit defines whether P34 is used as a normal output pin or the T8 output.

T8 and T16 Common Functions—CTR1(0D)01h

This register controls the functions common with the T8 and T16.

[Table 7](#) lists and briefly describes the fields for this register.



Table 7. CTR1(0D)01h T8 and T16 Common Functions

Field	Bit Position		Value	Description
Mode	7-----	R/W	0*	TRANSMIT Mode
			1	DEMODULATION Mode
P36_Out/ Capture_Input	-6-----	R/W	0*	TRANSMIT Mode Port Output
			1	T8/T16 Output DEMODULATION Mode
			0*	P31
			1	P20
T8/T16_Logic/ Edge_Detect	--54----	R/W	00**	TRANSMIT Mode AND
			01	OR
			10	NOR
			11	NAND
				DEMODULATION Mode
			00**	Falling Edge
			01	Rising Edge
			10	Both Edges
			11	Reserved
			Transmit_Submode/ Glitch_Filter	----32--
01	PING-PONG Mode			
10	T16_Out = 0			
11	T16_Out = 1			
	DEMODULATION Mode			
00	No Filter			
01	4 SCLK Cycle			
10	8 SCLK Cycle			
11	Reserved			
Initial_T8_Out/ Rising Edge	-----1-	R/W		
			1	T8_OUT is 1 Initially
		R W	0	DEMODULATION Mode No Rising Edge
			1	Rising Edge Detected
			0	No Effect
			1	Reset Flag to 0

**Table 7. CTR1(0D)01h T8 and T16 Common Functions (Continued)**

Field	Bit Position		Value	Description
Initial_T16_Out/ Falling_Edge	-----0	R/W	0	TRANSMIT Mode
			1	T16_OUT is 0 Initially
				T16_OUT is 1 Initially
				DEMODULATION Mode
		R	0	No Falling Edge
			1	Falling Edge Detected
		W	0	No Effect
			1	Reset Flag to 0

*Default at Power-On Reset.

*Indicates the value upon Power-On Reset. Not reset with a Stop Mode Recovery.

Mode

If the result is 0, the counter/timers are in TRANSMIT mode, else, they are in DEMODULATION mode.

P36_Out/Demodulator_Input

In TRANSMIT mode, this bit defines whether P36 is used as a normal output pin or the combined output of T8 and T16.

In DEMODULATION mode, this bit defines whether the input signal to the Counter/Timers is from P20 or P31.

If the input signal is from Port 31, a capture event generates an IRQ2 interrupt. To prevent generating an IRQ2, either disable the IRQ2 interrupt by clearing its IMR bit D2 or use P20 as the input.

T8/T16_Logic/Edge_Detect

In TRANSMIT mode, this field defines how the outputs of T8 and T16 are combined (AND, OR, NOR, NAND).

In DEMODULATION mode, this field defines which edge is detected by the edge detector.

Transmit_Submode/Glitch_Filter

In TRANSMIT mode, this field defines whether T8 and T16 are in the PING-PONG mode or in independent Normal operation mode. Setting this field to 'Normal Operation mode' terminates the 'PING-PONG mode' operation. When set to 10, T16 is immediately forced to a 0; a setting of 11 forces T16 to output a 1.

In DEMODULATION mode, this field defines the width of the glitch that must be filtered out.



Initial_T8_Out/Rising_Edge

In TRANSMIT mode, if 0, the output of T8 is set to 0 when it starts to count. If 1, the output of T8 is set to 1 when it starts to count. When the counter is not enabled and this bit is set to 1 or 0, T8_OUT is set to the opposite state of this bit. This ensures that when the clock is enabled, a transition occurs to the initial state set by CTR1, D1.

In DEMODULATION mode, this bit is set to 1 when a rising edge is detected in the input signal. In order to reset the mode, a 1 should be written to this location.

Initial_T16 Out/Falling_Edge

In TRANSMIT mode, if it is 0, the output of T16 is set to 0 when it starts to count. If it is 1, the output of T16 is set to 1 when it starts to count. This bit is effective only in NORMAL or PING-PONG mode (CTR1, D3; D2). When the counter is not enabled and this bit is set, T16_OUT is set to the opposite state of this bit. This ensures that when the clock is enabled, a transition occurs to the initial state set by CTR1, D0.

In DEMODULATION mode, this bit is set to 1 when a falling edge is detected in the input signal. In order to reset it, a 1 should be written to this location.

► **Note:** *Modifying CTR1 (D1 or D0) while the counters are enabled causes unpredictable output from T8/T16_OUT.*

CTR2 Counter/Timer 16 Control Register—CTR2(0D)02h

Table 8 lists and briefly describes the fields for this register.

Table 8. CTR2(0D)02h: Counter/Timer16 Control Register

Field	Bit Position		Value	Description
T16_Enable	7-----	R	0*	Counter Disabled
			1	Counter Enabled
		W	0	Stop Counter
			1	Enable Counter
Single/Modulo-N	-6-----	R/W	0	TRANSMIT Mode
			1	Modulo-N
			0	Single Pass
			1	DEMODULATION Mode
Time_Out	--5-----	R	0**	T16 Recognizes Edge
			1	T16 Does Not Recognize Edge
		W	0	No Counter Timeout
			1	Counter Timeout Occurred
			0	No Effect
			1	Reset Flag to 0

**Table 8. CTR2(0D)02h: Counter/Timer16 Control Register (Continued)**

Field	Bit Position		Value	Description
T16_Clock	---43---	R/W	00** 01 10 11	SCLK SCLK/2 SCLK/4 SCLK/8
Capture_INT_Mask	-----2--	R/W	0** 1	Disable Data Capture Int. Enable Data Capture Int.
Counter_INT_Mask	-----1-	R/W	0*	Disable Timeout Int. Enable Timeout Int.
P35_Out	-----0	R/W	0* 1	P35 as Port Output T16 Output on P35

*Indicates the value upon Power-On Reset.
**Indicates the value upon Power-On Reset. Not reset with a Stop Mode Recovery.

T16_Enable

This field enables T16 when set to 1.

Single/Modulo-N

In TRANSMIT mode, when set to 0, the counter reloads the initial value when it reaches the terminal count. When set to 1, the counter stops when the terminal count is reached.

In DEMODULATION mode, when set to 0, T16 captures and reloads on detection of all the edges. When set to 1, T16 captures and detects on the first edge but ignores the subsequent edges. For details, see [T16 DEMODULATION Mode](#) on page 36.

Time_Out

This bit is set when T16 times out (terminal count reached). To reset the bit, write a 1 to this location.

T16_Clock

This bit defines the frequency of the input signal to Counter/Timer16.

Capture_INT_Mask

This bit is set to allow an interrupt when data is captured into LO16 and HI16.

Counter_INT_Mask

Set this bit to allow an interrupt when T16 times out.



P35_Out

This bit defines whether P35 is used as a normal output pin or T16 output.

CTR3 T8/T16 Control Register—CTR3(0D)03h

Table 9 lists and briefly describes the fields for this register. This register allow the T8 and T16 counters to be synchronized.

Table 9. CTR3(0D)03h T8/T16 Control Register

T16_Enable	7-----	R	0*	Counter Disabled
		R	1	Counter Enabled
		W	0	Stop Counter
		W	1	Enable Counter
T8 Enable	-6-----	R/W	0**	Counter Disabled
			1	Counter Enabled
			0	Stop Counter
			1	Enable Counter
Sync Mode	--5-----	R/W	0*	Disable Sync Mode
			1	Enable Sync Mode
Reserved	---43210	R/W	1	Always reads 11111
			x	No Effect

*Indicates the value upon Power-On Reset.

***Indicates the value upon Power-On Reset. Not reset with a Stop Mode Recovery.

Counter/Timer Functional Blocks

Input Circuit

The edge detector monitors the input signal on P31 or P20. Based on CTR1 D5–D4, a pulse is generated at the Pos Edge or Neg Edge line when an edge is detected. Glitches in the input signal that have a width less than specified (CTR1 D3, D2) are filtered out (see Figure 13).

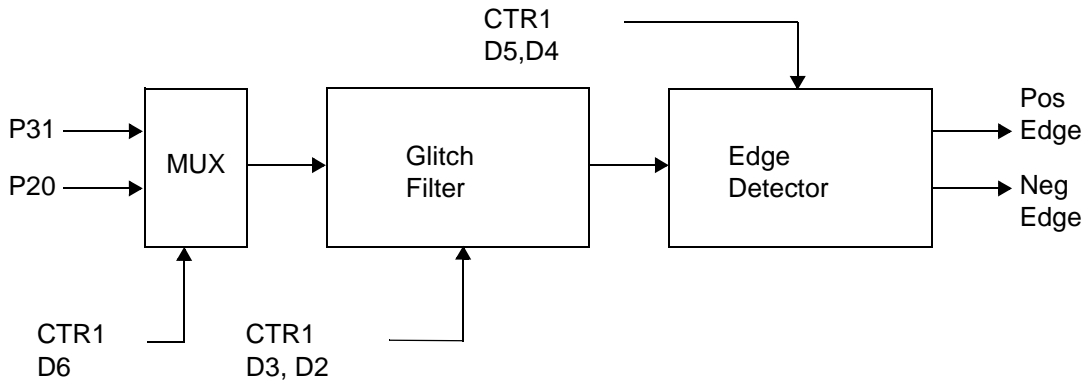

Figure 13. Glitch Filter Circuitry

T8 TRANSMIT Mode

Before T8 is enabled, the output of T8 depends on CTR1, D1. If it is 0, T8_OUT is 1; if it is 1, T8_OUT is 0. See [Figure 14](#) on page 30.

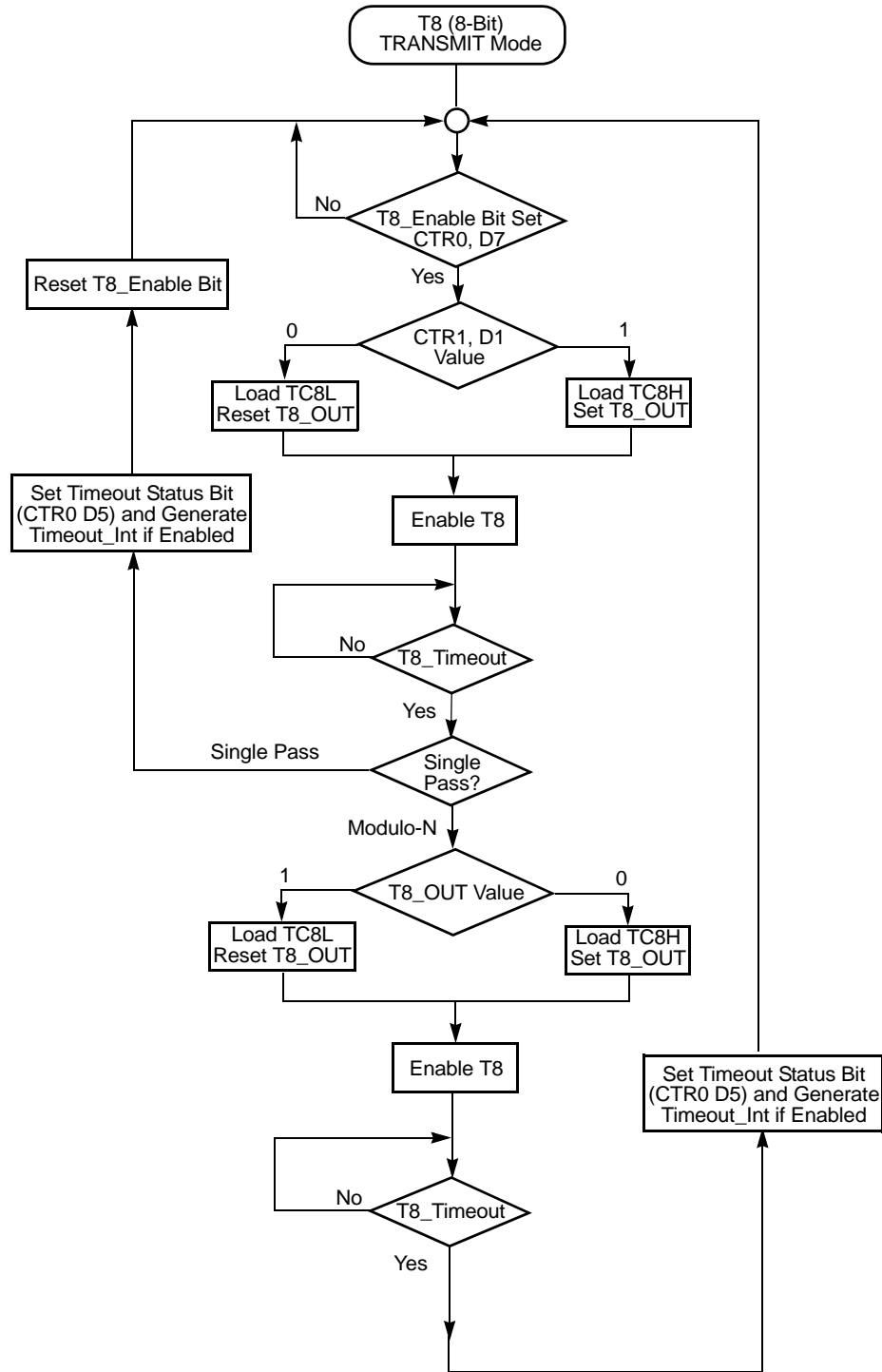

Figure 14. TRANSMIT Mode Flowchart



When T8 is enabled, the output T8_OUT switches to the initial value (CTR1, D1). If the initial value (CTR1, D1) is 0, TC8L is loaded, else, TC8H is loaded into the counter. In SINGLE-PASS mode (CTR0, D6), T8 counts down to 0 and stops, T8_OUT toggles, the timeout status bit (CTR0, D5) is set, and a timeout interrupt can be generated if it is enabled (CTR0, D1). In MODULO-N mode, upon reaching terminal count, T8_OUT is toggled, but no interrupt is generated. From that point, T8 loads a new count (if the T8_OUT level now is 0), TC8L is loaded; if it is 1, TC8H is loaded. T8 counts down to 0, toggles T8_OUT, and sets the timeout status bit (CTR0, D5), thereby generating an interrupt if enabled (CTR0, D1). One cycle is complete. T8 then loads from TC8H or TC8L according to the T8_OUT level and repeats the cycle. See Figure 15.

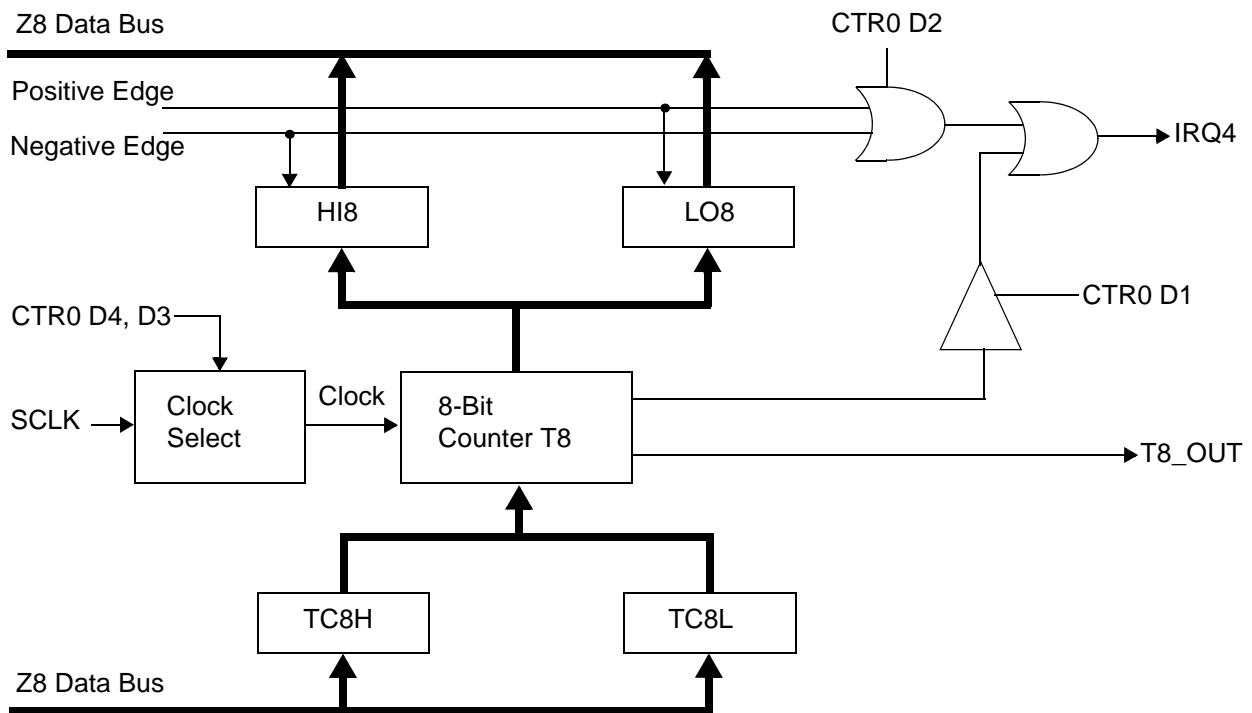

Figure 15. 8-Bit Counter/Timer Circuits

The values in TC8H or TC8L can be modified at any time. The new values take effect when they are loaded.

Caution: To ensure known operation do not write these registers at the time the values are to be loaded into the counter/timer. An initial count of 1 is not allowed (a non-function occurs). An initial count of 0 causes TC8 to count from 0 to FFh to FEh.

Note: The letter h denotes hexadecimal values.

Transition from 0 to FFh is not a timeout condition.



Caution: *Using the same instructions for stopping the counter/timers and setting the status bits is not recommended.*

Two successive commands are necessary. First, the counter/timers must be stopped. Second, the status bits must be reset. These commands are required because it takes one counter/timer clock interval for the initiated event to actually occur. See Figure 16 and Figure 17.

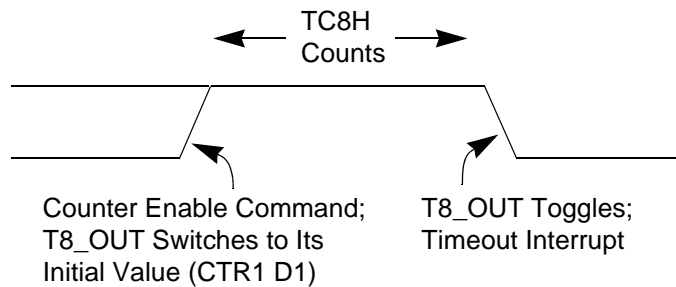

Figure 16. T8_OUT in SINGLE-PASS Mode

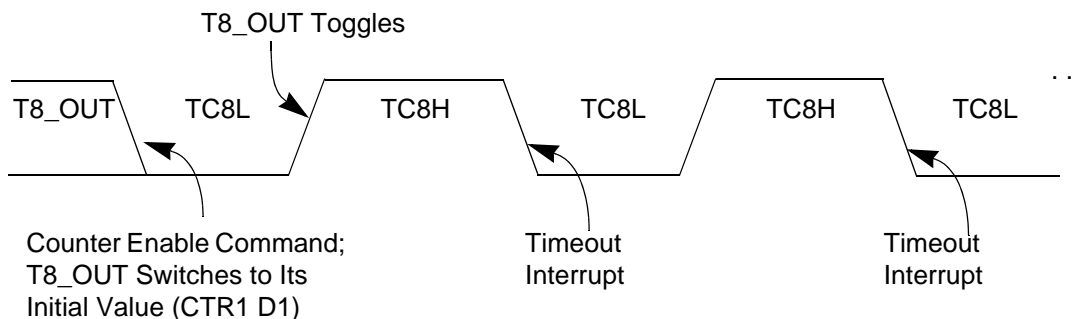

Figure 17. T8_OUT in MODULO-N Mode

T8 DEMODULATION Mode

You must program TC8L and TC8H to FFh. After T8 is enabled, when the first edge (rising, falling, or both depending on CTR1, D5; D4) is detected, it starts to count down. When a subsequent edge (rising, falling, or both depending on CTR1, D5; D4) is detected during counting, the current value of T8 is complemented and put into one of the capture registers. If it is a positive edge, data is put into LO8; if it is a negative edge, data is stored in HI8. From that point, one of the edge detect status bits (CTR1, D1; D0) is set, and an interrupt is generated if enabled (CTR0, D2). Meanwhile, T8 is loaded with FFh and starts counting again. If T8 reaches 0, the timeout status bit (CTR0, D5) is set, and an interrupt



can be generated if enabled (CTR0, D1). T8 then continues counting from FFh (see Figure 19 on page 34).

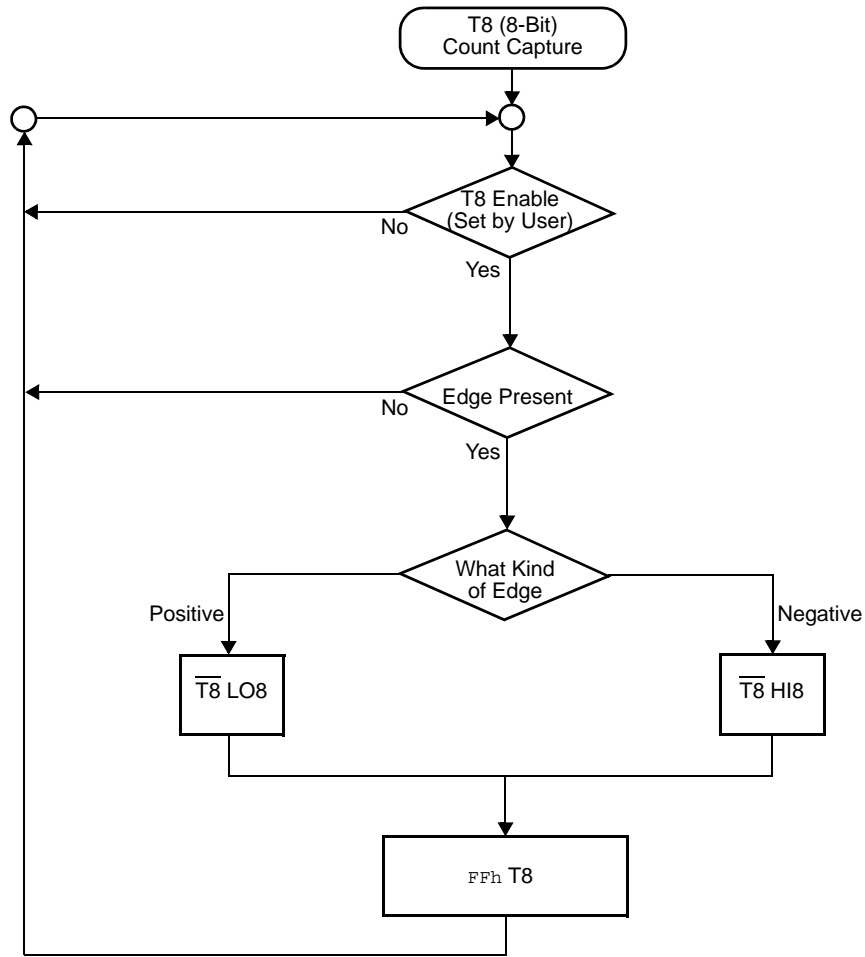

Figure 18. DEMODULATION Mode Count Capture Flowchart

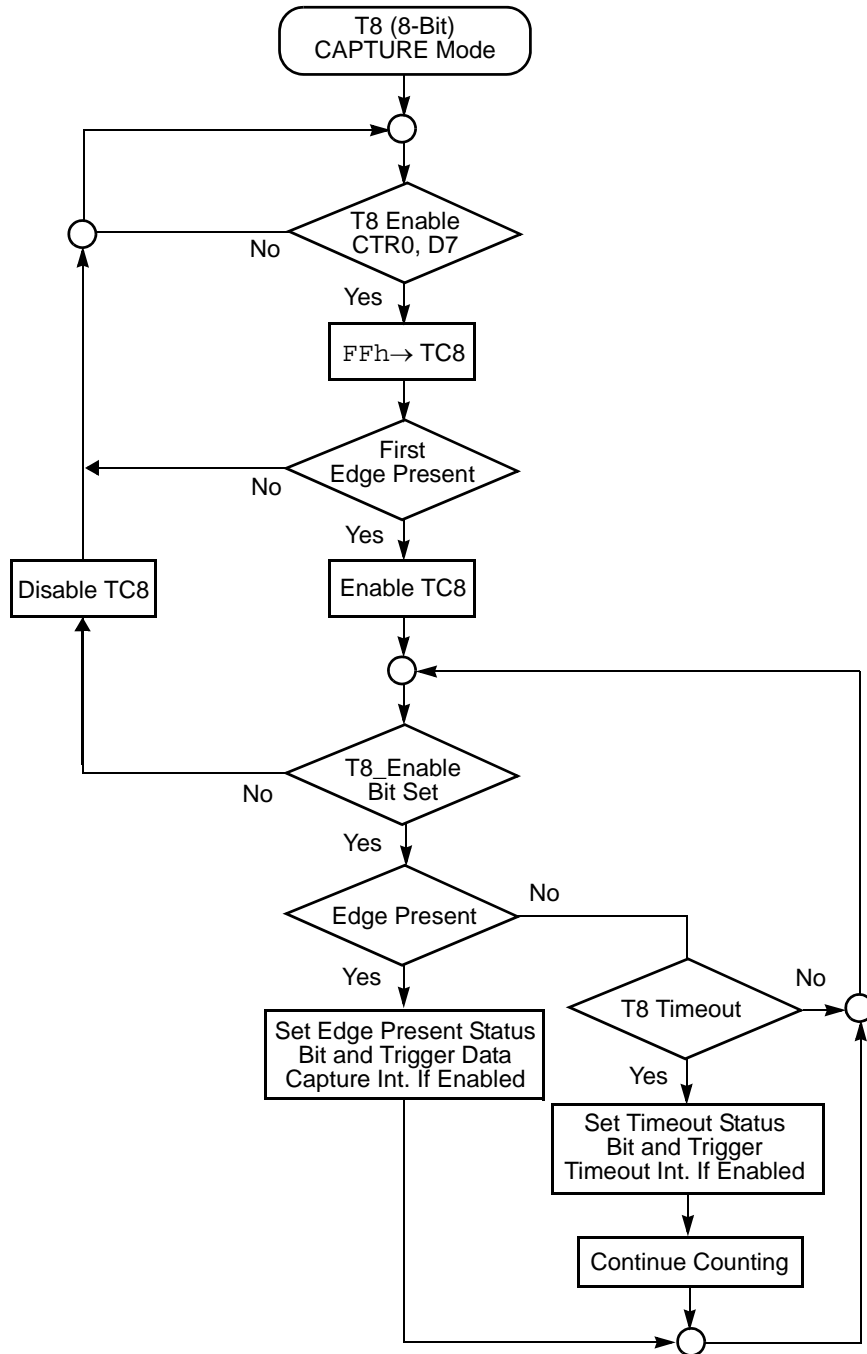

Figure 19. DEMODULATION Mode Flowchart

T16 TRANSMIT Mode

In NORMAL or PING-PONG mode, the output of T16 when not enabled, is dependent on CTR1, D0. If it is a 0, T16_OUT is a 1; if it is a 1, T16_OUT is 0. You can force the output of T16 to either a 0 or 1 whether it is enabled or not by programming CTR1 D3; D2 to a 10 or 11.

When T16 is enabled, TC16H * 256 + TC16L is loaded, and T16_OUT is switched to its initial value (CTR1, D0). When T16 counts down to 0, T16_OUT is toggled (in NORMAL or PING-PONG mode), an interrupt (CTR2, D1) is generated (if enabled), and a status bit (CTR2, D5) is set. See [Figure 20](#).

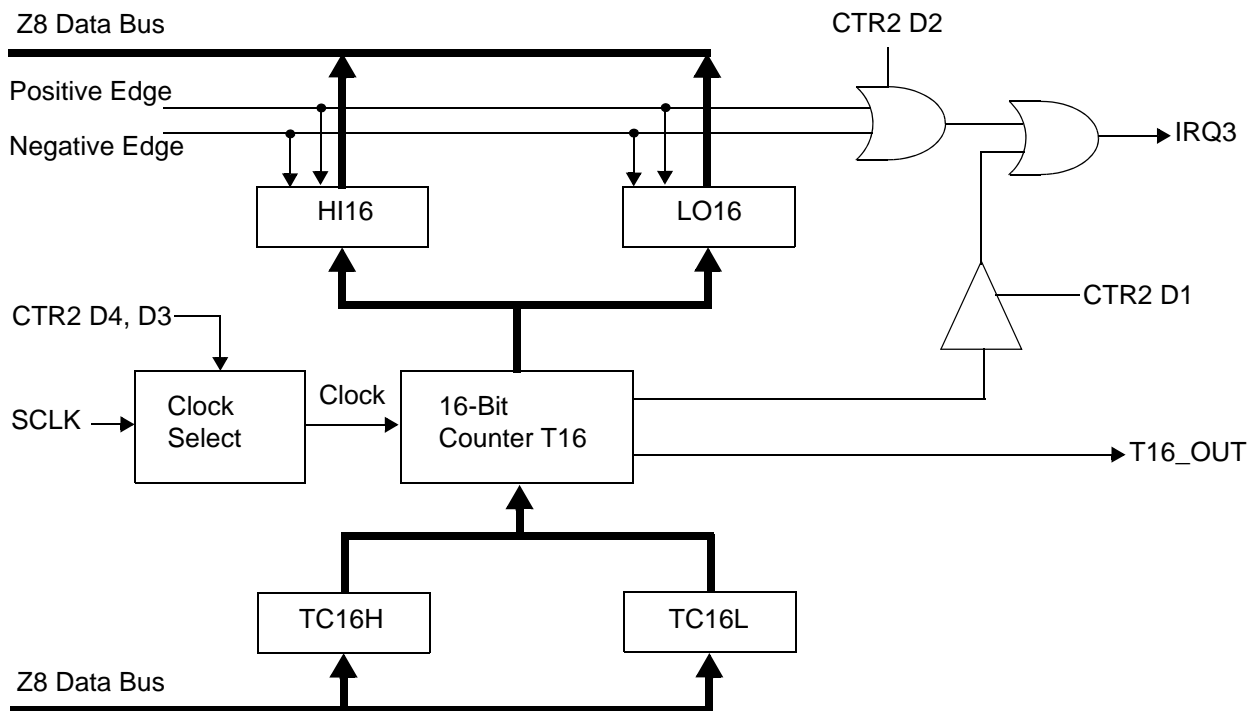

Figure 20. 16-Bit Counter/Timer Circuits

► **Note:** *Global interrupts override this function as described in [Interrupts](#) on page 39.*

If T16 is in SINGLE-PASS mode, it is stopped at this point (see [Figure 21](#) on page 36). If it is in MODULO-N mode, it is loaded with TC16H * 256 + TC16L, and the counting continues (see [Figure 22](#) on page 36).

The values in TC16H and TC16L can be modified at any time. The new values take effect when they are loaded.



Caution: Do not load these registers at the time the values are to be loaded into the counter/timer to ensure known operation. An initial count of 1 is not allowed. An initial count of 0 causes T16 to count from 0 to FFFFh to FFFEh. Transition from 0 to FFFFh is not a time-out condition.

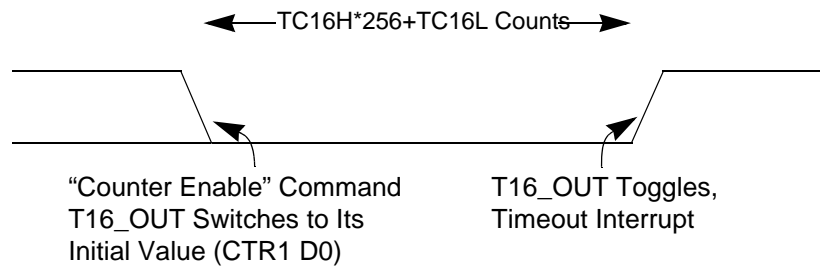

Figure 21. T16_OUT in SINGLE-PASS Mode

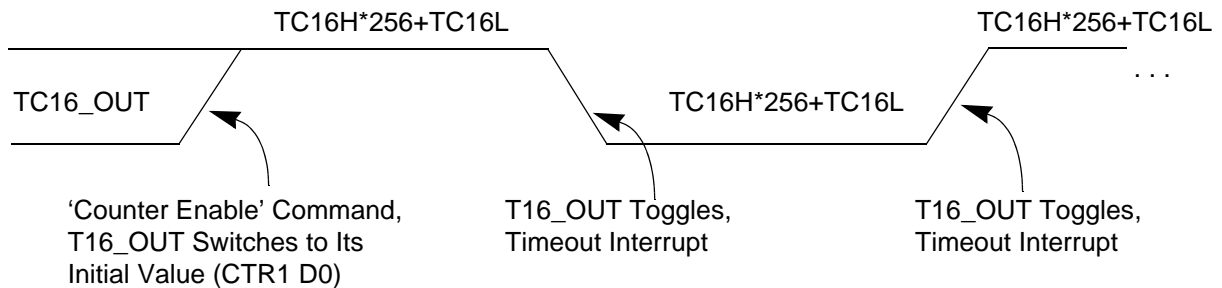

Figure 22. T16_OUT in MODULO-N Mode

T16 DEMODULATION Mode

You must program TC16L and TC16H to FFh. Once T16 is enabled, and the first edge (rising, falling, or both depending on CTR1 D5; D4) is detected, T16 captures HI16 and LO16, reloads, and begins counting.

If D6 of CTR2 Is 0

When a subsequent edge (rising, falling, or both depending on CTR1, D5; D4) is detected during counting, the current count in T16 is complemented and put into HI16 and LO16. When data is captured, one of the edge detect status bits (CTR1, D1; D0) is set, and an interrupt is generated if enabled (CTR2, D2). T16 is loaded with FFFFh and starts again.

This T16 mode is generally used to measure space time, the length of time between bursts of carrier signal (marks).

If D6 of CTR2 Is 1

T16 ignores the subsequent edges in the input signal and continues counting down. A timeout of T8 causes T16 to capture its current value and generate an interrupt if enabled (CTR2, D2). In this case, T16 does not reload and continues counting. If the D6 bit of CTR2 is toggled (by writing a 0 then a 1 to it), T16 captures and reloads on the next edge (rising, falling, or both depending on CTR1, D5; D4), continuing to ignore subsequent edges.

This T16 mode generally measures mark time, the length of an active carrier signal burst.

If T16 reaches 0, T16 continues counting from FFFFh. Meanwhile, a status bit (CTR2 D5) is set, and an interrupt timeout is generated if enabled (CTR2 D1).

PING-PONG Mode

This operation mode is valid only in TRANSMIT mode. T8 and T16 must be programmed in SINGLE-PASS mode (CTR0, D6; CTR2, D6), and Ping-Pong mode must be programmed in CTR1, D3; D2. You can begin the operation by enabling either T8 or T16 (CTR0, D7 or CTR2, D7). For example, if T8 is enabled, T8_OUT is set to this initial value (CTR1, D1). According to T8_OUT's level, TC8H or TC8L is loaded into T8. After the terminal count is reached, T8 is disabled, and T16 is enabled. T16_OUT then switches to its initial value (CTR1, D0), data from TC16H and TC16L is loaded, and T16 starts to count. After T16 reaches the terminal count, it stops, T8 is enabled again, repeating the entire cycle. Interrupts are allowed when T8 or T16 reaches terminal control (CTR0, D1; CTR2, D1). To stop the Ping-Pong operation, write 00 to bits D3 and D2 of CTR1. See Figure 23.

- **Note:** *Enabling Ping-Pong operation while the counter/timers are running might cause intermittent counter/timer function. Disable the counter/timers and reset the status Flags before instituting this operation.*

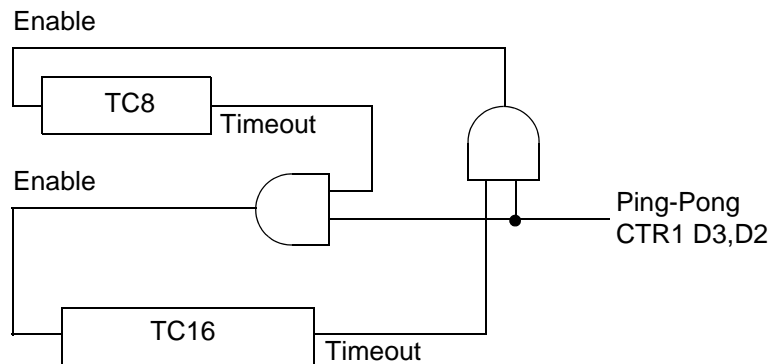

Figure 23. PING-PONG Mode Diagram

Initiating PING-PONG Mode

Ensure that both counter/timers are not running. Set T8 into SINGLE-PASS mode (CTR0, D6), set T16 into SINGLE-PASS mode (CTR2, D6), and set the PING-PONG mode (CTR1, D2; D3). These instructions can be in random order. Finally, start PING-PONG mode by enabling either T8 (CTR0, D7) or T16 (CTR2, D7). See Figure 23 on page 38.

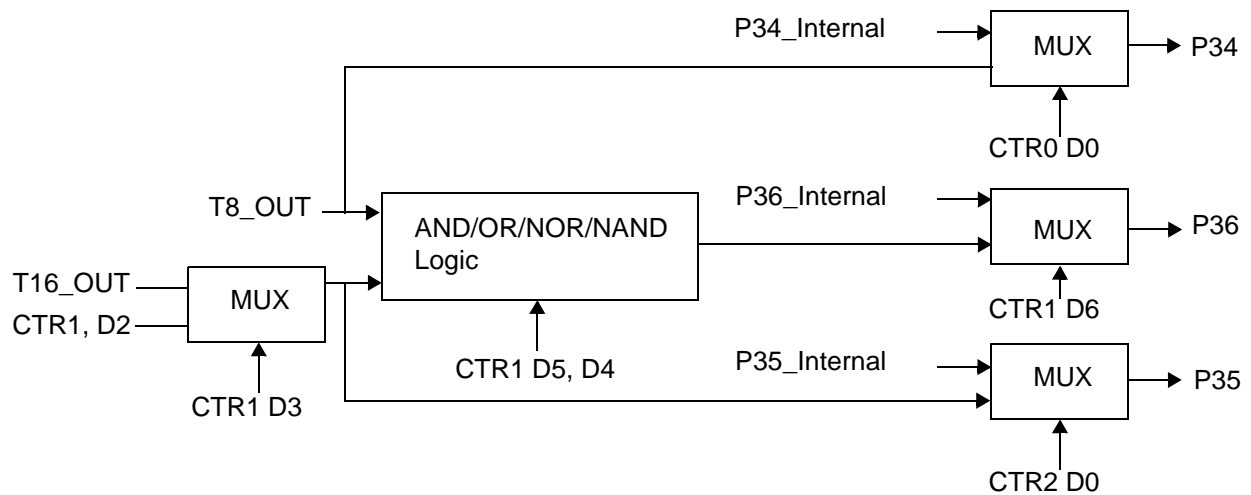

Figure 24. Output Circuit

The initial value of T8 or T16 must not be 1. If you stop the timer and restart the timer, reload the initial value to avoid an unknown previous value.

During PING-PONG Mode

The enable bits of T8 and T16 (CTR0, D7; CTR2, D7) are set and cleared alternately by hardware. The timeout bits (CTR0, D5; CTR2, D5) are set every time the counter/timers reach the terminal count.

Timer Output

The output logic for the timers is displayed in Figure 24. P34 is used to output T8-OUT when D0 of CTR0 is set. P35 is used to output the value of T16-OUT when D0 of CTR2 is set. When D6 of CTR1 is set, P36 outputs the logic combination of T8-OUT and T16-OUT determined by D5 and D4 of CTR1.



Interrupts

The Crimzon ZLR16300 features six different interrupts (see [Table 10](#) on page 41). The interrupts are maskable and prioritized (see [Figure 25](#) on page 40). The six sources are divided as follows:

- Three sources are claimed by Port 3 lines P33–P31
- Two by the counter/timers (see [Table 10](#) on page 41)
- One for low-voltage detection

The Interrupt Mask Register (globally or individually) enables or disables the six interrupt requests.

The source for IRQ is determined by bit 1 of the Port 3 mode register (P3M). When in DIGITAL mode, Pin P33 is the source. When in ANALOG mode the output of the Stop Mode Recovery source logic is used as the source for the interrupt. See [Figure 30](#) on page 47.

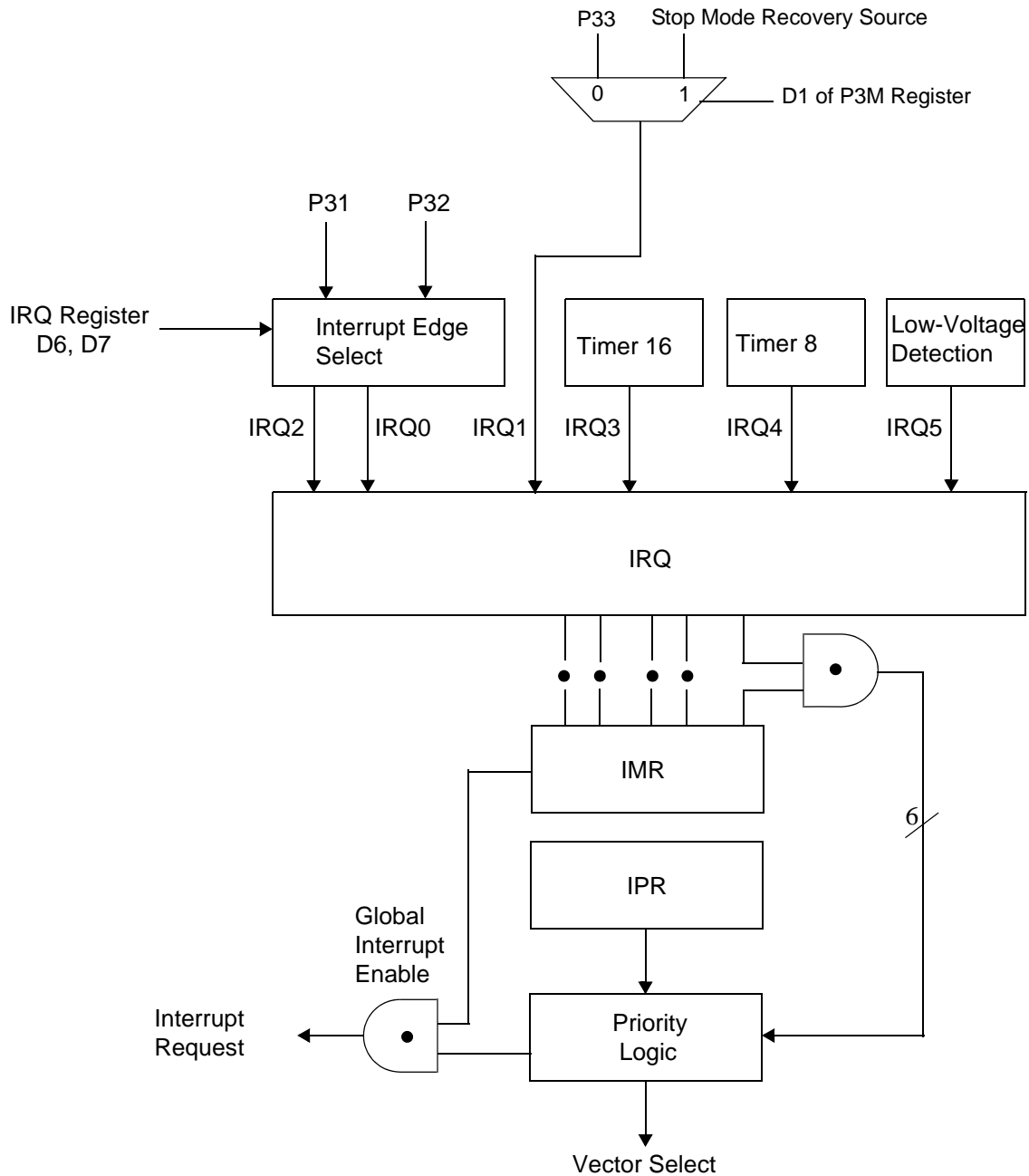

Figure 25. Interrupt Block Diagram

**Table 10. Interrupt Types, Sources, and Vectors**

Name	Source	Vector Location	Comments
IRQ0	P32	0,1	External (P32), Rising, Falling Edge Triggered
IRQ1	P33	2,3	External (P33), Falling Edge Triggered
IRQ2	P31, T _{IN}	4,5	External (P31), Rising, Falling Edge Triggered
IRQ3	T16	6,7	Internal
IRQ4	T8	8,9	Internal
IRQ5	LVD	10,11	Internal

When more than one interrupt is pending, priorities are resolved by a programmable priority encoder controlled by the Interrupt Priority Register. An interrupt machine cycle activates when an interrupt request is granted. As a result, all subsequent interrupts are disabled, and the Program Counter and Status Flags are saved. The cycle then branches to the Program Memory vector location reserved for that interrupt. All Crimzon ZLR16300 interrupts are vectored through locations in the Program Memory. This memory location and the next byte contain the 16-bit address of the interrupt service routine for that particular interrupt request. To accommodate polled interrupt systems, interrupt inputs are masked, and the Interrupt Request register is polled to determine which of the interrupt requests require service.

An interrupt resulting from AN1 is mapped into IRQ2, and an interrupt from AN2 is mapped into IRQ0. Interrupts IRQ2 and IRQ0 can be rising, falling, or both edge triggered. You can program these interrupts. The software can poll to identify the state of the pin.

Programming bits for the Interrupt Edge Select are located in the IRQ Register (R250), bits D7 and D6. [Table 11](#) indicates the IRQ configuration.

Table 11. IRQ Register

IRQ		Interrupt Edge	
D7	D6	IRQ2 (P31)	IRQ0 (P32)
0	0	F	F
0	1	F	R
1	0	R	F
1	1	R/F	R/F

Note: F = Falling Edge; R = Rising Edge.

Clock

The device's on-chip oscillator has a high-gain, parallel-resonant amplifier for connection to a crystal, ceramic resonator, or any suitable external clock source (XTAL1 = Input, XTAL2 = Output). The crystal must be AT cut, 1 MHz to 8 MHz (maximum) with a series resistance (RS) less than or equal to 100 Ω . The on-chip oscillator is driven with a suitable external clock source.

The crystal must be connected across XTAL1 and XTAL2 using the recommended capacitors from each pin to ground. The typical capacitor value is 10 pF for 8 MHz.

► **Note:** Check with the crystal supplier for the optimum capacitance.

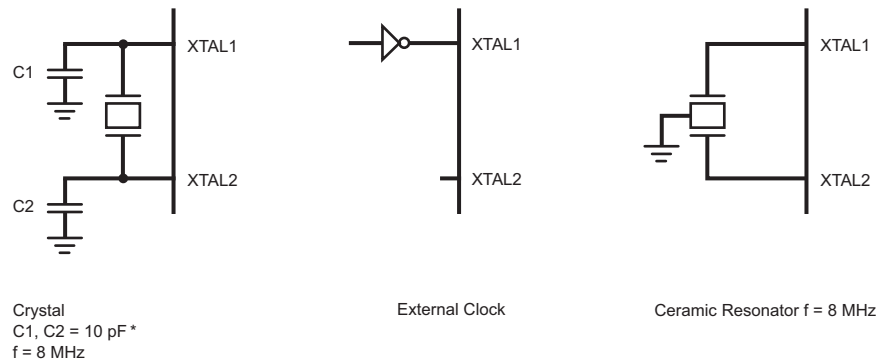

*Note: preliminary value.

Figure 26. Oscillator Configuration

Maxim's IR MCU supports crystal, resonator, and oscillator. Most resonators have a frequency tolerance of less than $\pm 0.5\%$, which is enough for remote control application. Resonator has a very fast startup time, which is around few hundred microseconds. Most crystals have a frequency tolerance of less than 50 ppm ($\pm 0.005\%$). However, crystal needs longer startup time than the resonator. The large loading capacitance slows down the oscillation startup time. Maxim suggests not to use more than 10 pF loading capacitor for the crystal. If the stray capacitance of the PCB or the crystal is high, the loading capacitance C1 and C2 must be reduced further to ensure stable oscillation before the T_{POR} (Power-On Reset time is typically 5–6 ms, see [Table 18](#) on page 75).

For SMR operation, bit 5 of SMR register allows you to select the SMR delay, which is the T_{POR} . If SMR delay is not selected, the MCU executes instruction immediately after it wakes up from the STOP mode. If resonator or crystal is used as a clock source then SMR delay needs to be selected (bit 5 of SMR = 1).



For both resonator and crystal oscillator, the oscillation ground must go directly to the ground pin of the microcontroller. The oscillation ground must use the shortest distance from the microcontroller ground pin and it must be isolated from other connections.

Power Management

Power-On Reset

A timer circuit clocked by a dedicated on-board RC-oscillator is used for the Power-On Reset timer function. The POR time allows V_{DD} and the oscillator circuit to stabilize before instruction execution begins.

The POR timer circuit is a one-shot timer triggered by one of three conditions:

1. Power Fail to Power OK status, including Waking up from V_{BO} Standby.
2. Stop Mode Recovery (if D5 of SMR = 1).
3. WDT Timeout.

The POR timer is 2.5 ms minimum. Bit 5 of the Stop-Mode Register determines whether the POR timer is bypassed after Stop Mode Recovery (typical for external clock).

HALT Mode

This instruction turns Off the internal CPU clock, but not the XTAL oscillation. The counter/timers and external interrupts IRQ0, IRQ1, IRQ2, IRQ3, IRQ4, and IRQ5 remain active. The devices are recovered by interrupts, either externally or internally generated. An interrupt request must be executed (enabled) to exit HALT mode. After the interrupt service routine, the program continues from the instruction after the HALT.

STOP Mode

This instruction turns OFF the internal clock and external crystal oscillation, reducing the standby current to 10 μ A or less. STOP mode is terminated only by a reset, such as WDT timeout, POR or SMR. This condition causes the processor to restart the application program at address 000Ch. In order to enter STOP (or HALT) mode, first flush the instruction pipeline to avoid suspending execution in mid-instruction. Execute an NOP instruction (Opcode = FFh) immediately before the appropriate sleep instruction, as follows:

```
FF      NOP      ; clear the pipeline
6F      STOP     ; enter Stop Mode

or

FF      NOP      ; clear the pipeline
7F      HALT     ; enter Halt Mode
```



Port Configuration

Port Configuration Register

The Port Configuration (PCON) register (see Figure 27) configures the comparator output on Port 3. It is located in the expanded register file at Bank F, location 00.

PCON (0F) 00H

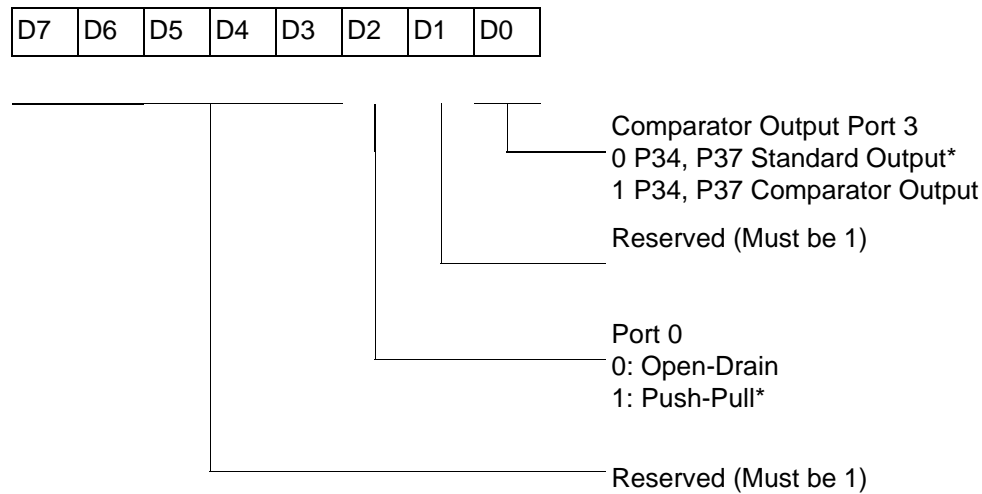

*Default setting after reset.

Figure 27. Port Configuration Register (PCON) (Write Only)

Comparator Output Port 3 (D0)

Bit 0 controls the comparator used in Port 3. A 1 in this location brings the comparator outputs to P34 and P37, and a 0 releases the Port to its standard I/O configuration.

Port 0 Output Mode (D2)

Bit 2 controls the output mode of port 0. A 1 in this location sets the output to push-pull, and a 0 sets the output to open-drain.

Stop Mode Recovery

Stop Mode Recovery Register

This register selects the clock divide value and determines the mode of Stop Mode Recovery (see Figure 28 on page 45). All bits are write only except bit 7, which is read only. Bit



7 is a Flag bit that is hardware set on the condition of Stop recovery and reset by a power-on cycle. Bit 6 controls whether a low level or a high level at the XOR-gate input (see Figure 30 on page 47) is required from the recovery source. Bit 5 controls the reset delay after recovery. Bits D2, D3, and D4 of the SMR register specify the source of the Stop Mode Recovery signal. Bits D0 determines if SCLK/TCLK are divided by 16 or not. The SMR is located in Bank F of the Expanded Register File at address 0Bh.

SMR (0F) 0BH

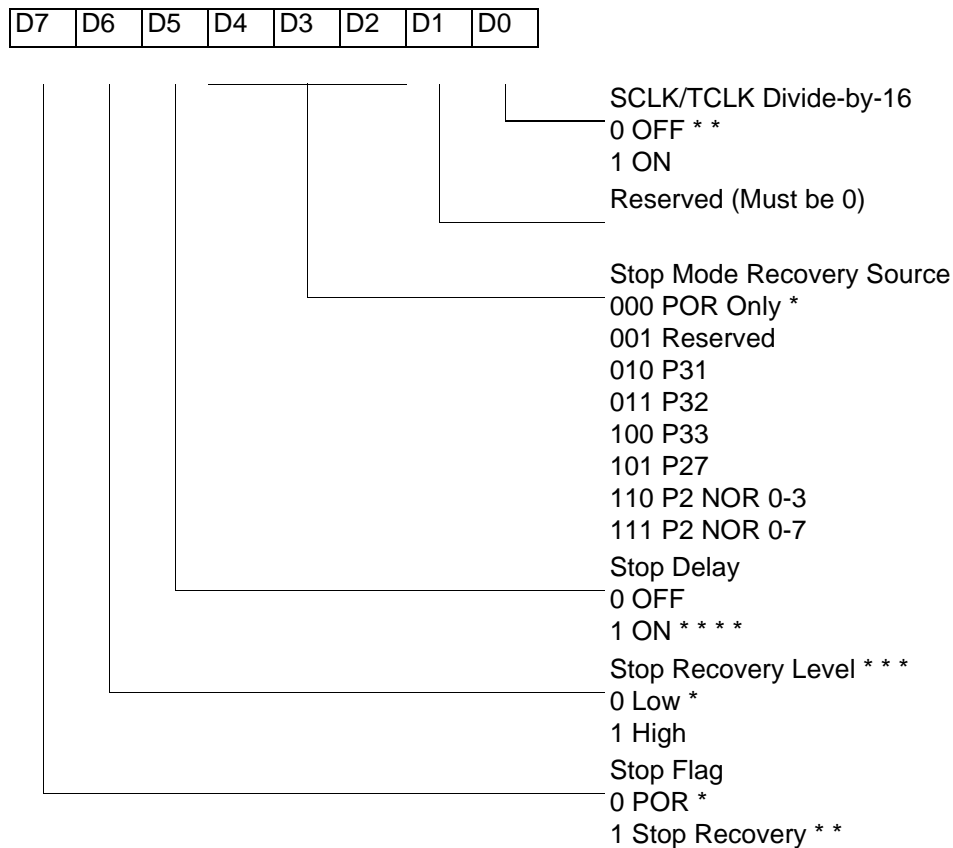

*Default after Power-On Reset or Watchdog Reset.
 **Default setting after Reset and Stop Mode Recovery.
 ***At the XOR gate input.
 ****Default setting after reset. Must be 1 if using a crystal or resonator clock source.

Figure 28. Stop Mode Recovery Register

SCLK/TCLK Divide-by-16 Select (D0)

D0 of the SMR controls a divide-by-16 prescaler of SCLK/TCLK (see Figure 29 on page 46). This control selectively reduces device power consumption during normal processor



execution (SCLK control) and/or HALT mode (where TCLK sources interrupt logic). After Stop Mode Recovery, this bit is set to 0.

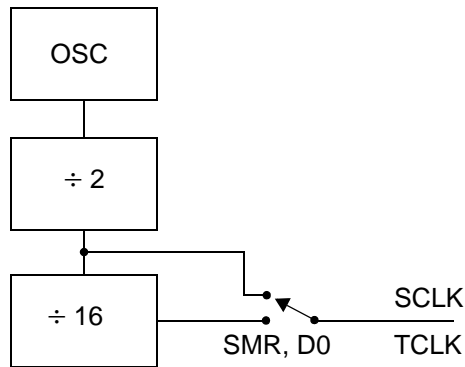

Figure 29. SCLK Circuit

Stop Mode Recovery Register 2—SMR2(0F)0DH

Table 12 lists and describes the fields for this register.

Table 12. SMR2(F)0DH:Stop Mode Recovery Register 2*

Field	Bit Position	Value	Description
Reserved	7-----	0	Reserved (Must be 0)
Recovery Level	-6-----	W 0 [†] 1	Low High
Reserved	--5-----	0	Reserved (Must be 0)
Source	---432--	W 000 [†] 001 010 011 100 101 110 111	A. POR Only B. NAND of P23–P20 C. NAND of P27–P20 D. NOR of P33–P31 E. NAND of P33–P31 F. NOR of P33–P31, P00, P07 G. NAND of P33–P31, P00, P07 H. NAND of P33–P31, P22–P20
Reserved	-----10	00	Reserved (Must be 0)

*Port pins configured as outputs are ignored as an SMR recovery source.

[†]Indicates the value at Power-On Reset.



Stop Mode Recovery Source (D2, D3, and D4)

These three bits of the SMR specify the wake-up source of the Stop recovery (see Figure 30 on page 47 and Table 13 on page 48).

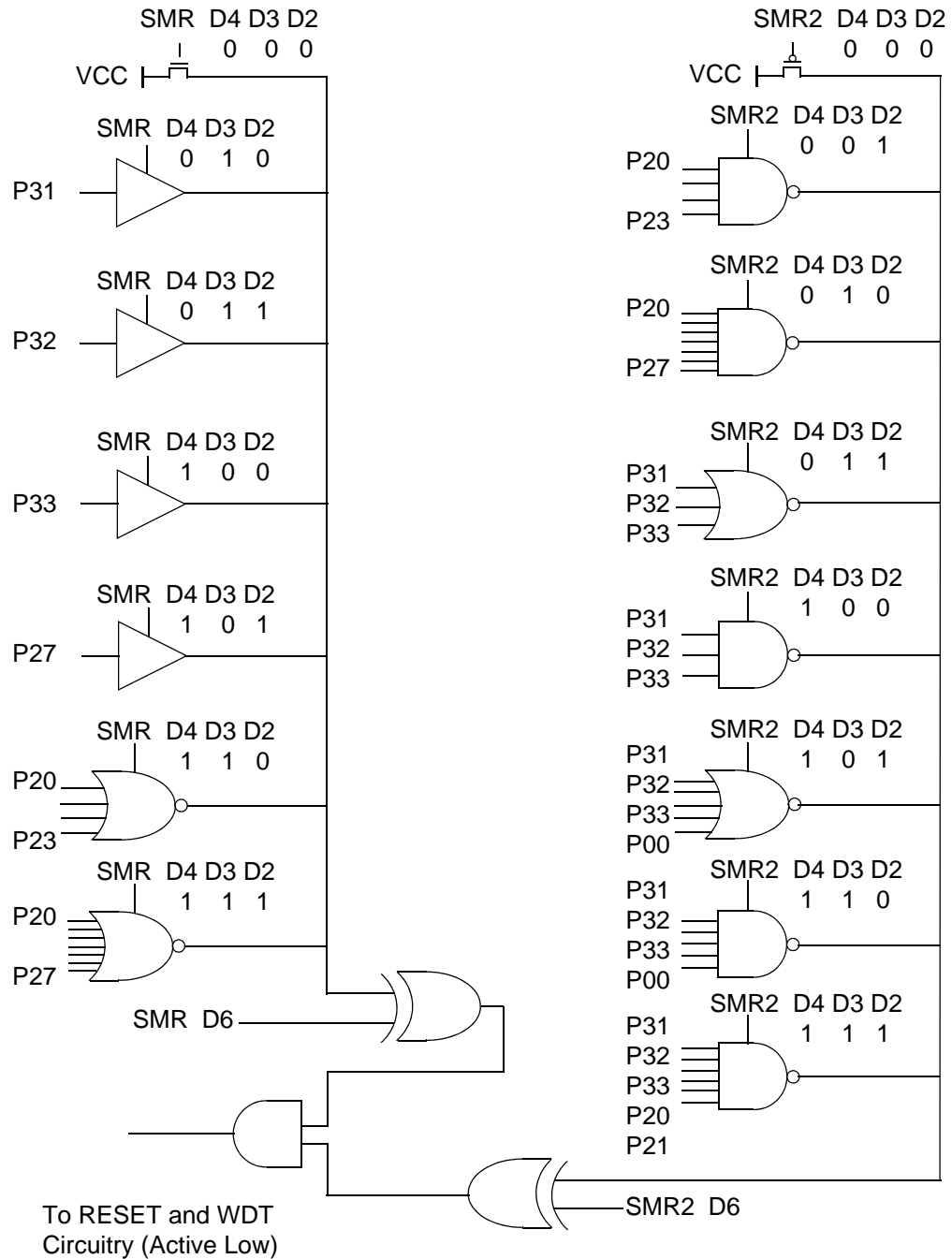

Figure 30. Stop Mode Recovery Source

**Table 13. Stop Mode Recovery Source**

SMR: 432			Operation
D4	D3	D2	Description of Action
0	0	0	POR and/or external reset recovery
0	0	1	Reserved
0	1	0	P31 transition
0	1	1	P32 transition
1	0	0	P33 transition
1	0	1	P27 transition
1	1	0	Logical NOR of P20 through P23
1	1	1	Logical NOR of P20 through P27

- **Note:** Any Port 2 bit defined as an output drives the corresponding input to the default state. This condition allows the remaining inputs to control the AND/OR function. For other recovery sources, see [Stop Mode Recovery Register 2 \(SMR2\)](#).

Stop Mode Recovery Delay Select (D5)

This bit, if Low, disables the T_{POR} delay after Stop Mode Recovery. The default configuration of this bit is 1. If the 'fast' wake-up is selected, the Stop Mode Recovery source must be kept active for at least 10 T_{pC} .

- **Note:** This bit must be set to 1 if using a crystal or resonator clock source. The T_{POR} delay allows the clock source to stabilize before executing instructions.

Stop Mode Recovery Edge Select (D6)

A 1 in this bit position indicates that a High level on any one of the recovery sources wakes the Crimzon ZLR16300 from STOP mode. A 0 indicates Low level recovery. The default is 0 on POR.

Cold or Warm Start (D7)

This bit is read only. It is set to 1 when the device is recovered from STOP mode. The bit is set to 0 when the device reset is other than SMR.

Stop Mode Recovery Register 2 (SMR2)

This register determines the mode of Stop Mode Recovery for SMR2 (see [Figure 31](#) on page 49).



SMR2 (0F) DH

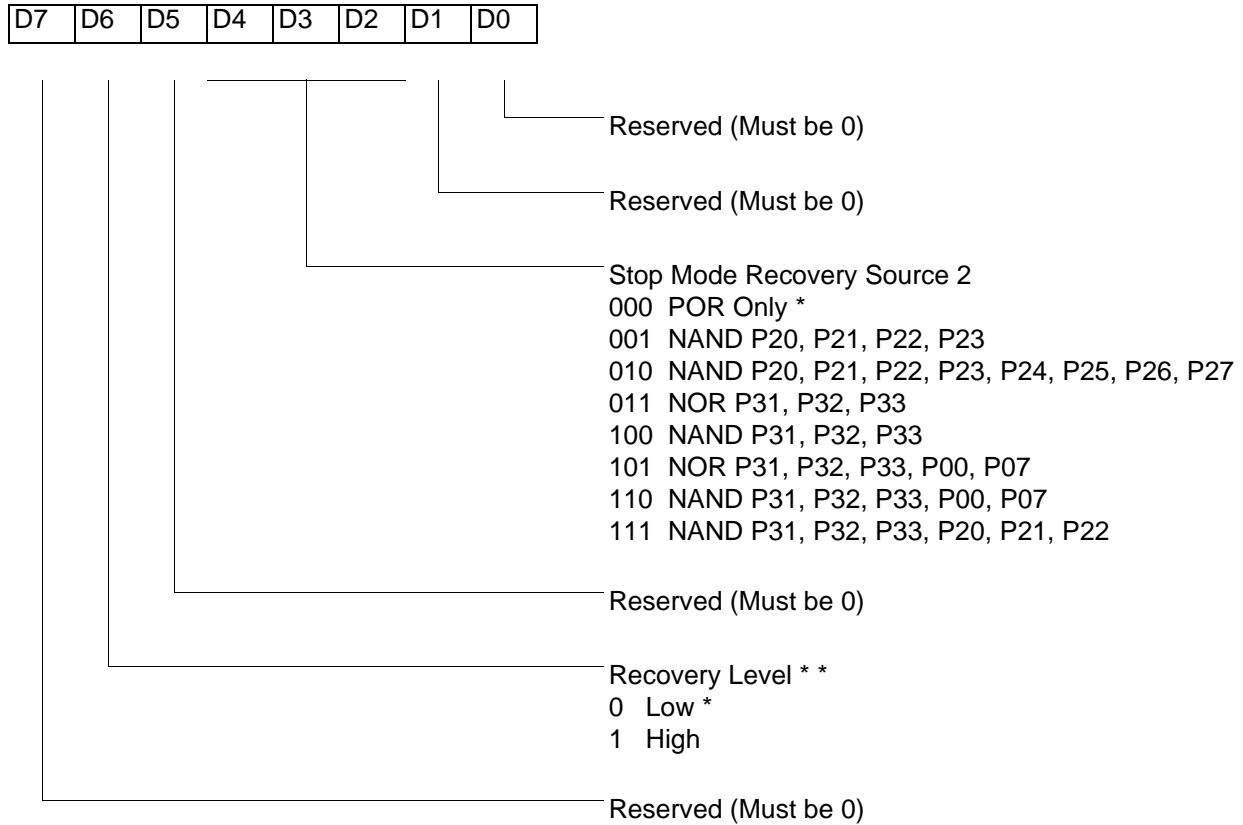

Note: If used in conjunction with SMR, either of the two specified events causes a Stop Mode Recovery.
 *Default setting after reset.
 **At the XOR gate input.

Figure 31. Stop Mode Recovery Register 2 ((0F) DH:D2–D4, D6 Write Only)

If SMR2 is used in conjunction with SMR, either of the specified events causes a Stop Mode Recovery.

► **Note:** Port pins configured as outputs are ignored as an SMR or SMR2 recovery source. For example, if the NAND or P23–P20 is selected as the recovery source and P20 is configured as an output, the remaining SMR pins (P23–P21) form the NAND equation.



Watchdog Timer Mode

Watchdog Timer Mode Register (WDTMR)

The Watchdog Timer is a retriggerable one-shot timer that resets the Z8 if it reaches its terminal count. The WDT must initially be enabled by executing the WDT instruction. On subsequent executions of the WDT instruction, the WDT is refreshed. The WDT circuit is driven by an on-board RC-oscillator. The WDT instruction affects the Zero (Z), Sign (S), and Overflow (V) Flags.

The POR clock source the internal RC-oscillator. Bits 0 and 1 of the WDT register control a tap circuit that determines the minimum timeout period. Bit 2 determines whether the WDT is active during HALT, and Bit 3 determines WDT activity during STOP. Bits 4 through 7 are reserved (see Figure 32). This register is accessible only during the first 60 processor cycles (120 XTAL clocks) from the execution of the first instruction after Power-On Reset, Watchdog Reset, or a Stop Mode Recovery (see Figure 31 on page 49). After this point, the register cannot be modified by any means (intentional or otherwise). The WDTMR cannot be read. The register is located in Bank F of the Expanded Register File at address location 0FH. It is organized as displayed in Figure 32.

WDTMR (0F) 0FH

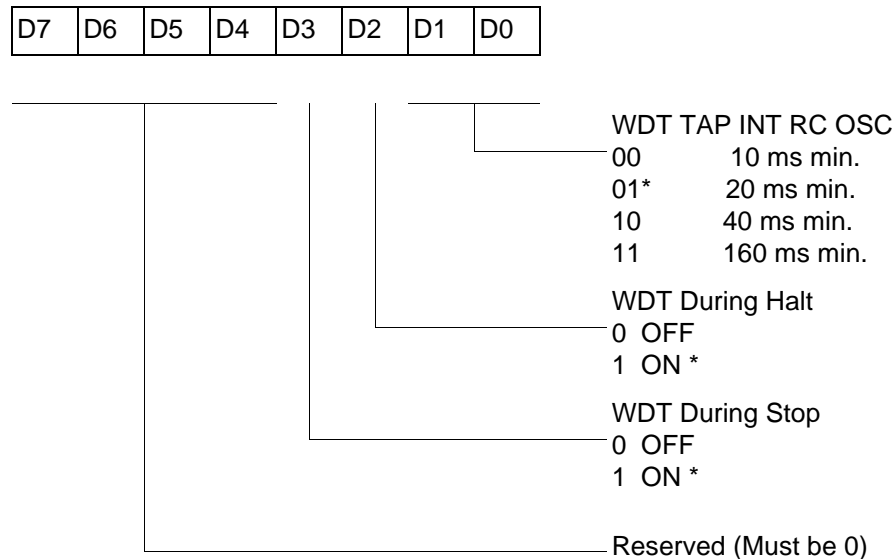

*Default setting after reset.

Figure 32. Watchdog Timer Mode Register (Write Only)



WDT Time Select (D0, D1)

This bit selects the WDT time period. It is configured as indicated in [Table 14](#).

Table 14. Watchdog Timer Time Select

D1	D0	Timeout of Internal RC-Oscillator
0	0	10 ms min.
0	1	20 ms min.
1	0	40 ms min.
1	1	160 ms min.

WDTMR During Halt (D2)

This bit determines whether the WDT is active or not during HALT mode. A 1 indicates active during HALT. The default is 1. See [Figure 33](#) on page 52.

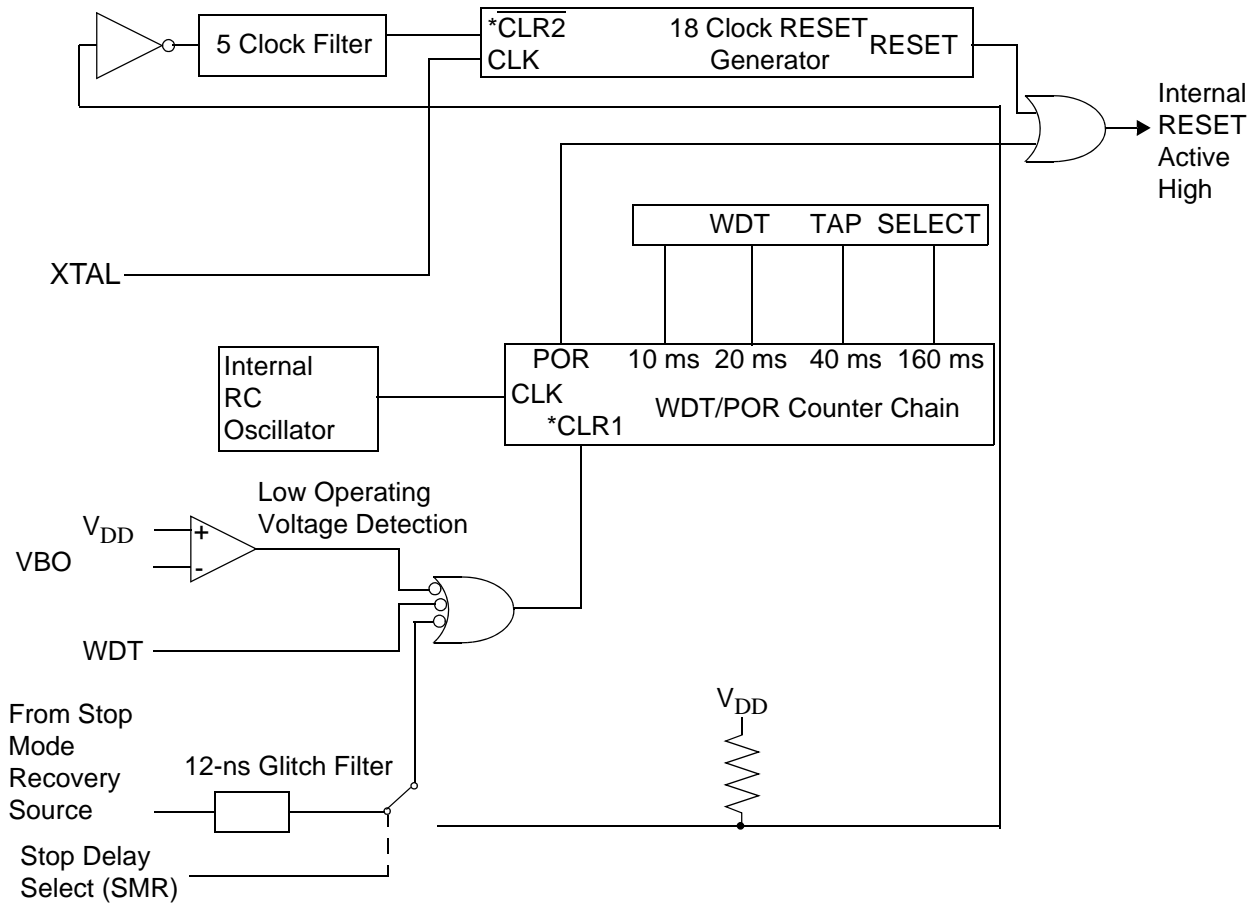

*CLR1 and $\overline{\text{CLR2}}$ enable the WDT/POR and 18 Clock Reset timers respectively upon a Low-to-High input translation.

Figure 33. Resets and WDT

WDTMR During Stop (D3)

This bit determines whether or not the WDT is active during STOP mode. A 1 indicates active during STOP. The default is 1.

ROM Selectable Options

There are five ROM Selectable Options to choose from based on ROM code requirements. These options are listed in [Table 15](#) on page 53.

**Table 15. ROM Selectable Options**

Port 00–03 Pull-Ups	ON/OFF
Port 04–07 Pull-Ups	ON/OFF
Port 20–27 Pull-Up Port 3 Pull-Ups	ON/OFF
Port 3 Pull-Ups	ON/OFF
Watchdog Timer at Power-On Reset	ON/OFF

Voltage Brownout/Standby

An on-chip Voltage Comparator checks that the V_{DD} is at the required level for correct operation of the device. Reset is globally driven when V_{DD} falls below V_{BO} . A small drop in V_{DD} causes the XTAL1 and XTAL2 circuitry to stop the crystal or resonator clock. If the V_{DD} is allowed to stay above V_{RAM} , the RAM content is preserved. When the power level is returned to above V_{BO} , the device performs a POR and functions normally.

Low-Voltage Detection

Low-Voltage Detection Register—LVD(0D)0CH

► **Note:** *Voltage detection does not work at STOP mode.*

Field	Bit Position			Description
LVD	765432---			Reserved
	-----2	R	1 0*	HVD Flag set HVD Flag reset
	-----1-	R	1 0*	LVD Flag set LVD Flag reset
	-----0	R/W	1 0*	Enable VD Disable VD

*Default after POR.

► **Note:** *Do not modify register P01M while checking a low-voltage condition. Switching noise of both ports 0 and 1 together might trigger the LVD Flag.*



Voltage Detection and Flags

The Voltage Detection register (LVD, register 0Ch at the expanded register bank 0Dh) offers an option of monitoring the V_{CC} voltage. The Voltage Detection is enabled when bit 0 of LVD register is set. When Voltage Detection is enabled, the V_{CC} level is monitored in real time. The Flags in the LVD register valid 20 us after Voltage Detection is enabled. The HVD Flag (bit 2 of the LVD register) is set only if V_{CC} is lower than the V_{HVD}. When Voltage Detection is enabled, the LVD Flag also triggers IRQ5. The IRQ bit 5 latches the low-voltage condition until it is cleared by instructions or reset. The IRQ5 interrupt is served if it is enabled in the IMR register. Otherwise, bit 5 of IRQ register is latched as a Flag only.

► **Note:** *If it is necessary to receive an LVD interrupt upon power-up at an operating voltage lower than the low battery detect threshold, enable interrupts using the Enable Interrupt instruction (EI) prior to enabling the voltage detection.*

Expanded Register File Control Registers (0D)

The expanded register file control registers (0D) are displayed in [Figure 34](#) through [Figure 38](#) on page 59.

CTR0 (0D) 00H

D7	D6	D5	D4	D3	D2	D1	D0
----	----	----	----	----	----	----	----

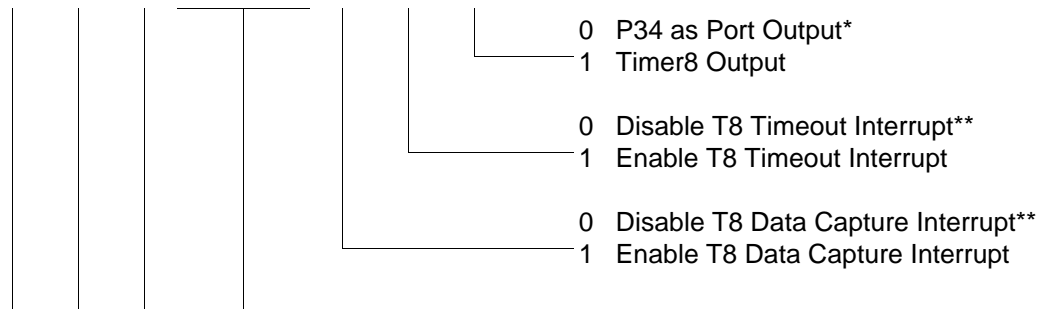



CTR0 (0D) 00H

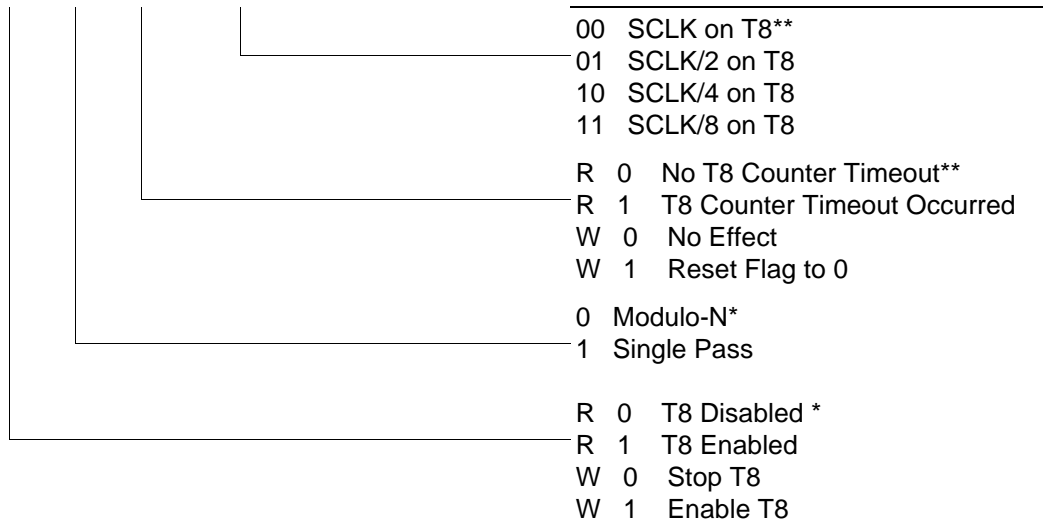

*Default setting after reset.

**Default setting after Reset. Not reset with a Stop Mode Recovery.

Figure 34. TC8 Control Register ((0D) 00H: Read/Write Except Where Noted)



CTR1 (0D) 01H

D7	D6	D5	D4	D3	D2	D1	D0
----	----	----	----	----	----	----	----

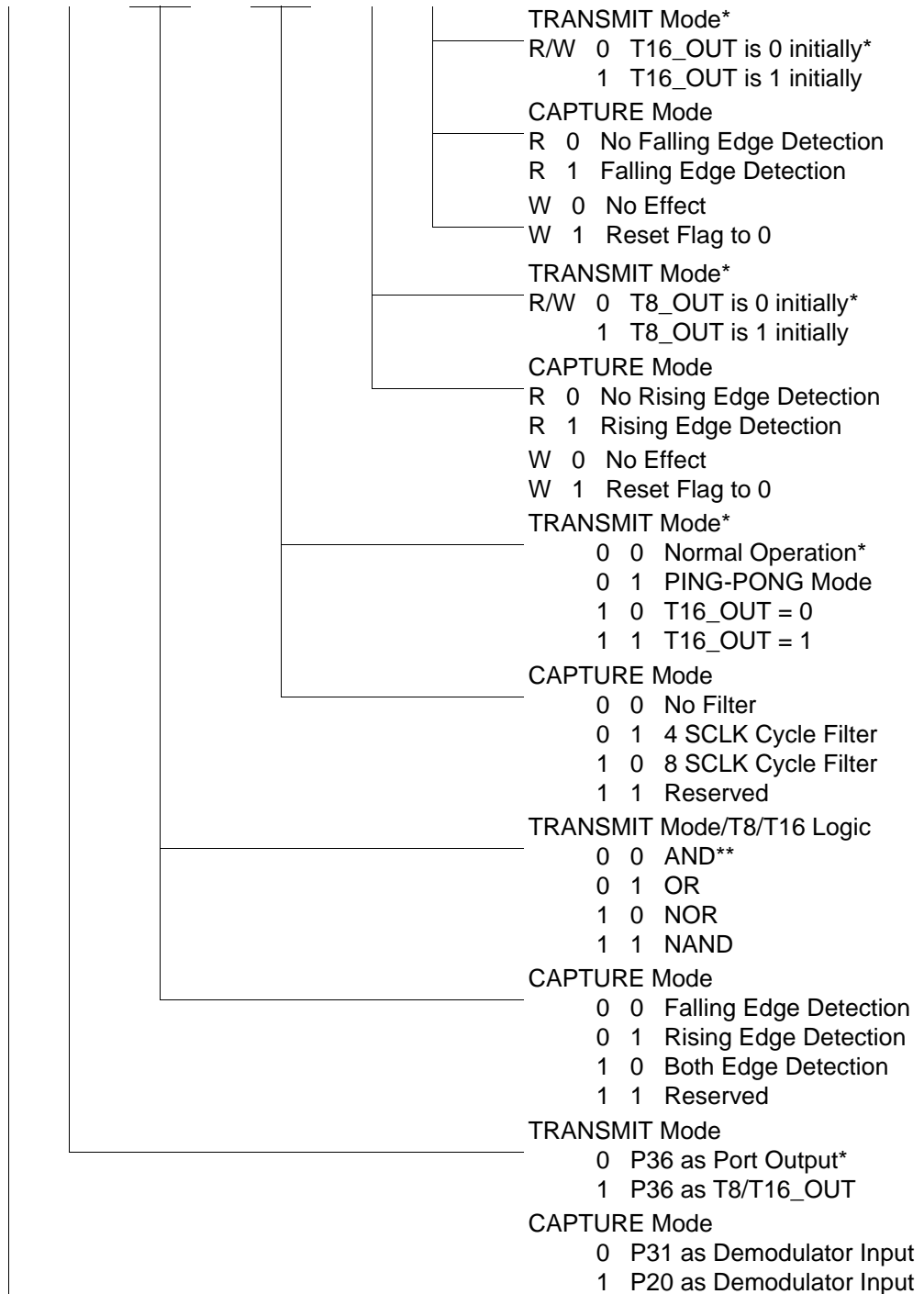



CTR1 (0D) 01H

		TRANSMIT/CAPTURE Mode
Default setting after reset.		0 TRANSMIT Mode
**Default setting after Reset. Not reset with a Stop Mode recovery.		1 CAPTURE Mode

Figure 35. T8 and T16 Common Control Functions ((0D) 01H: Read/Write)

- **Notes:** *Ensure to differentiate the TRANSMIT mode from CAPTURE mode. Depending on the operation of these two modes, the CTR1 bit has different functions.*

Changing from one mode to another cannot be performed without disabling the counter/timers.

CTR2 (0D) 02H

D7	D6	D5	D4	D3	D2	D1	D0
----	----	----	----	----	----	----	----

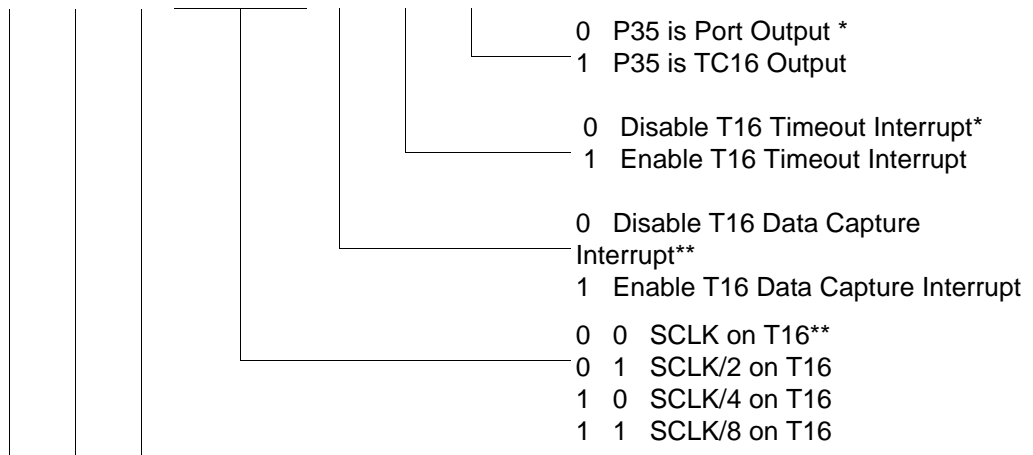

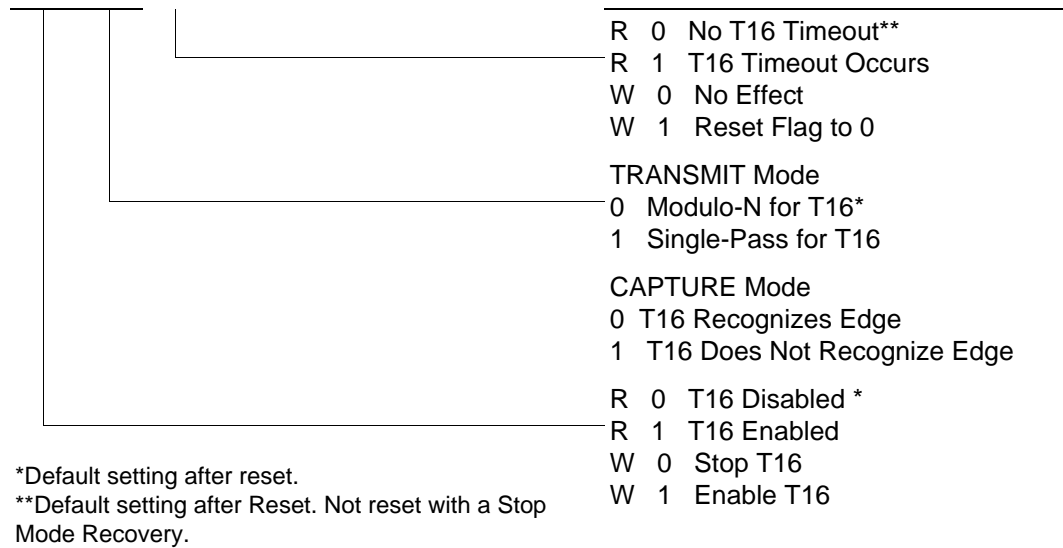

Figure 36. T16 Control Register ((0D) 02H: Read/Write Except Where Noted)

CTR3 (0D) 03H

D7	D6	D5	D4	D3	D2	D1	D0
----	----	----	----	----	----	----	----

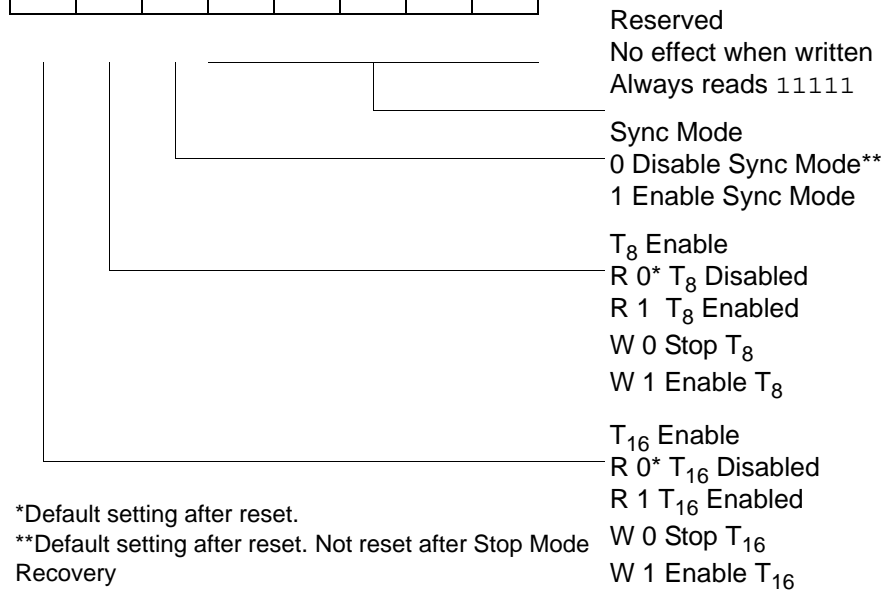

Figure 37. T8/T16 control Register (0D) 03H: Read/Write (Except Where Noted)



► **Note:** *If Sync Mode is enabled, the first pulse of T8 (carrier) is always synchronized with T16 (demodulated signal). It can always provide a full carrier pulse.*

LVD (0D) 0CH

D7	D6	D5	D4	D3	D2	D1	D0
----	----	----	----	----	----	----	----

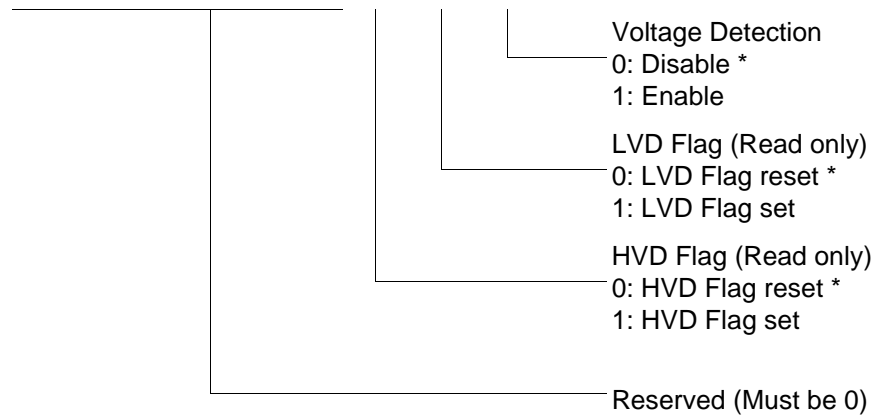

*Default setting after reset.

Figure 38. Voltage Detection Register



Expanded Register File Control Registers (0F)

The expanded register file control registers (0F) are displayed in [Figure 39](#) through [Figure 52](#) on page 68.

PCON (0F) 00H

D7	D6	D5	D4	D3	D2	D1	D0
----	----	----	----	----	----	----	----

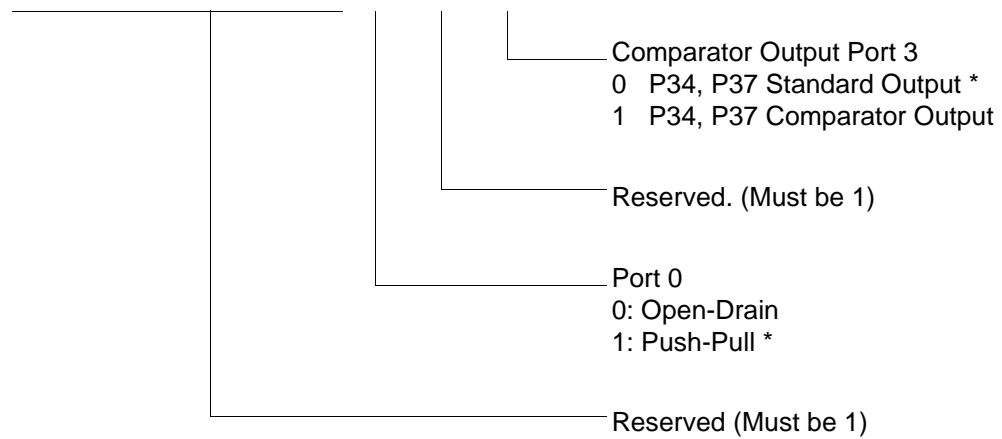

*Default setting after reset.

Figure 39. Port Configuration Register (PCON) ((0F)00H: Write Only)



SMR (0F) 0BH

D7	D6	D5	D4	D3	D2	D1	D0
----	----	----	----	----	----	----	----



- *Default setting after Reset.
- **Set after Stop Mode Recovery.
- ** *At the XOR gate input.
- * * *Default setting after reset. Must be 1 if using a crystal or resonator clock source. Not reset with a Stop Mode Recovery.
- * * * *Default setting after Power-On Reset.

Figure 40. Stop Mode Recovery Register ((0F) 0BH: D6–D0=Write Only, D7=Read Only)



SMR2 (0F) 0DH

D7	D6	D5	D4	D3	D2	D1	D0
----	----	----	----	----	----	----	----

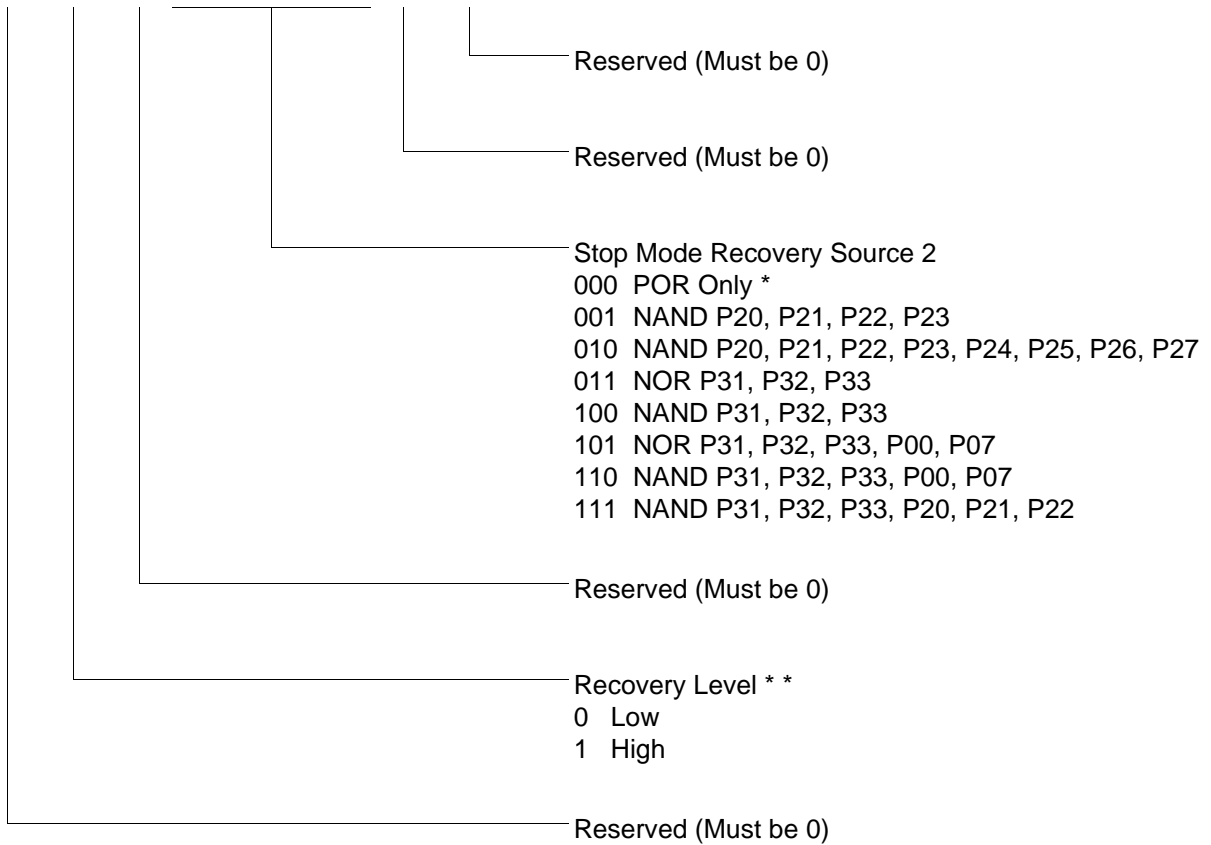

Note: If used in conjunction with SMR, either of the two specified events causes a Stop Mode Recovery.

*Default setting after reset. Not reset with a Stop Mode Recovery.

**At the XOR gate input

Figure 41. Stop Mode Recovery Register 2 ((0F) 0DH: D2–D4, D6 Write Only)



WDTMR (0F) 0FH

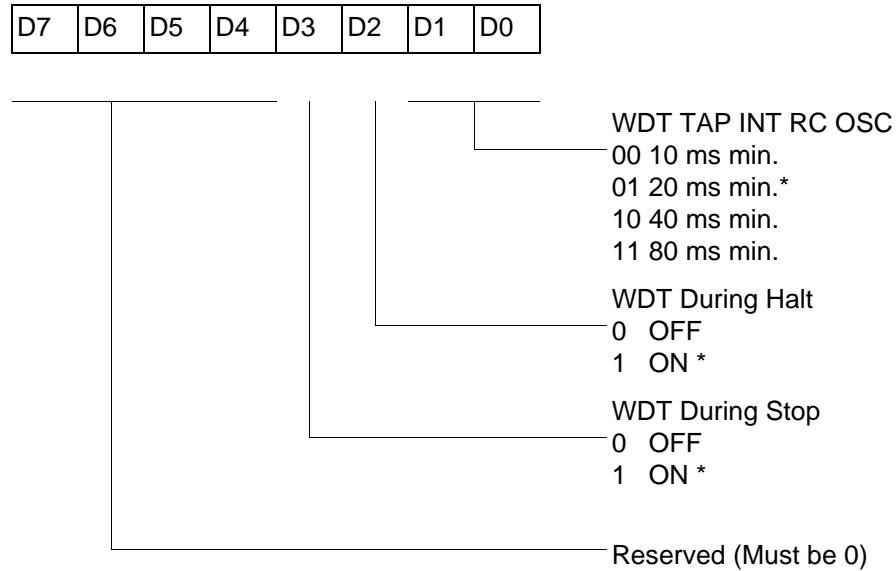

*Default setting after reset. Not reset with a Stop Mode Recovery.

Figure 42. Watchdog Timer Register ((0F) 0FH: Write Only)

Standard Control Registers

The standard control registers are displayed in [Figure 43](#) through [Figure 52](#) on page 68.

R246 P2M (F6H)

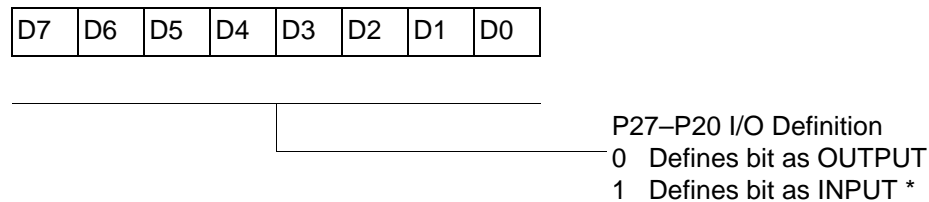

*Default setting after reset. Not reset with a Stop Mode Recovery.

Figure 43. Port 2 Mode Register (F6H: Write Only)



R247 P3M (F7H)

D7	D6	D5	D4	D3	D2	D1	D0
----	----	----	----	----	----	----	----

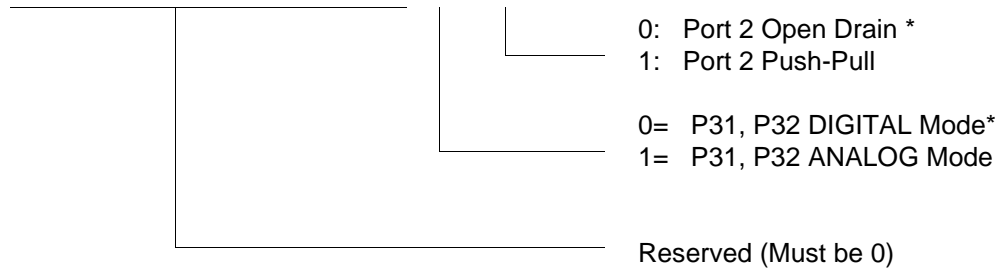

*Default setting after reset. Not reset with a Stop Mode Recovery.

Figure 44. Port 3 Mode Register (F7H: Write Only)

R248 P01M (F8H)

D7	D6	D5	D4	D3	D2	D1	D0
----	----	----	----	----	----	----	----

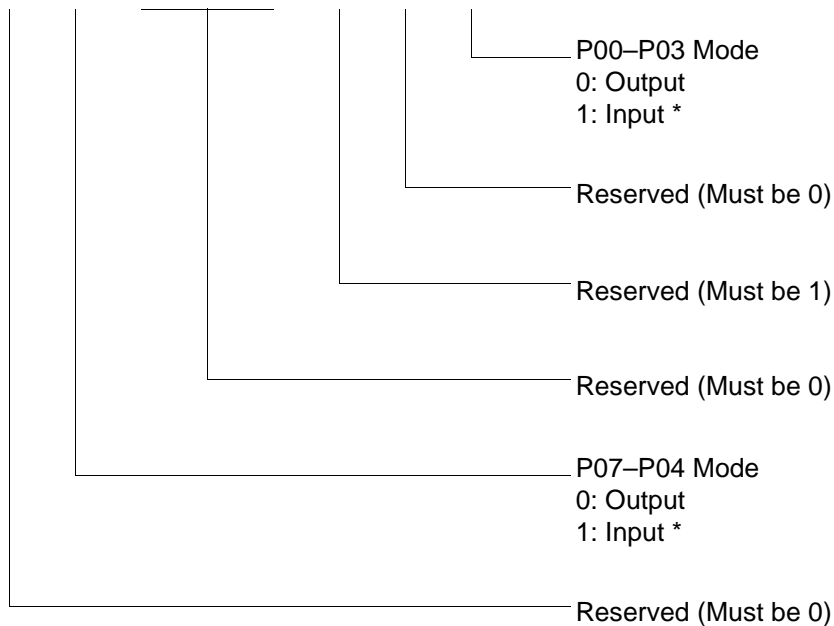

*Default setting after reset; only P00, P01 and P07 are available on 20-pin configurations.

Figure 45. Port 0 Register (F8H: Write Only)



R249 IPR (F9H)

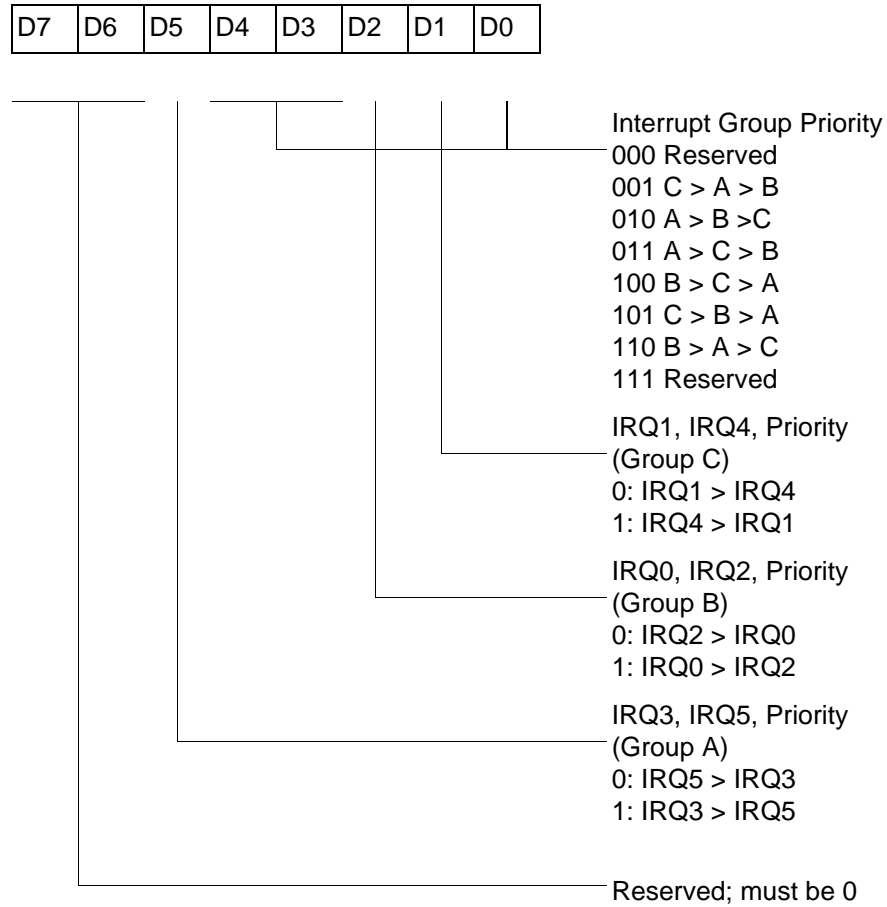

Figure 46. Interrupt Priority Register (F9H: Write Only)



R250 IRQ (FAH)

D7	D6	D5	D4	D3	D2	D1	D0
----	----	----	----	----	----	----	----

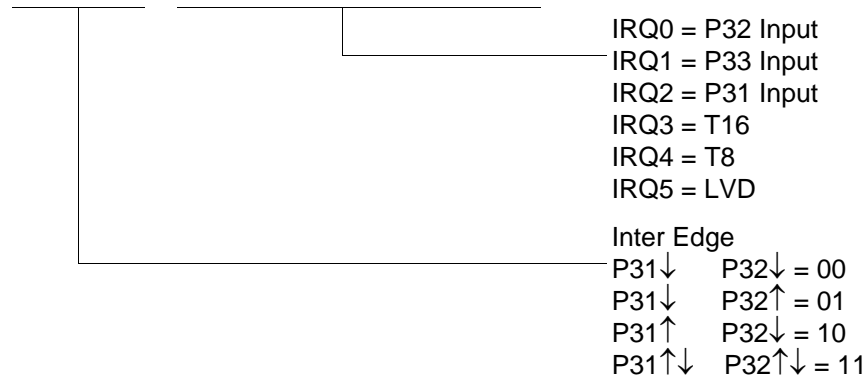
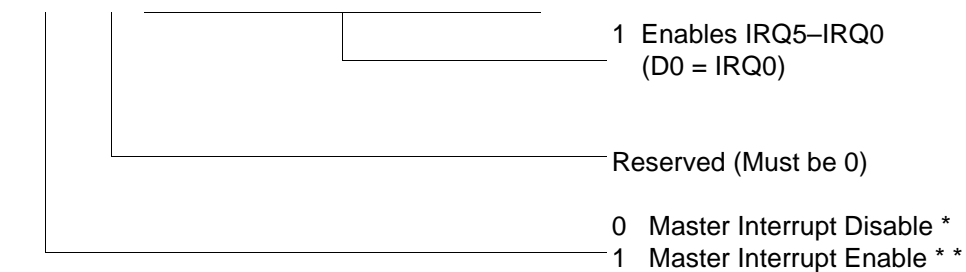

Figure 47. Interrupt Request Register (FAH: Read/Write)

R251 IMR (FBH)

D7	D6	D5	D4	D3	D2	D1	D0
----	----	----	----	----	----	----	----



*Default setting after reset.

**Only by using EI, DI instruction; DI is required before changing the IMR register.

Figure 48. Interrupt Mask Register (FBH: Read/Write)



R252 Flags (FCH)

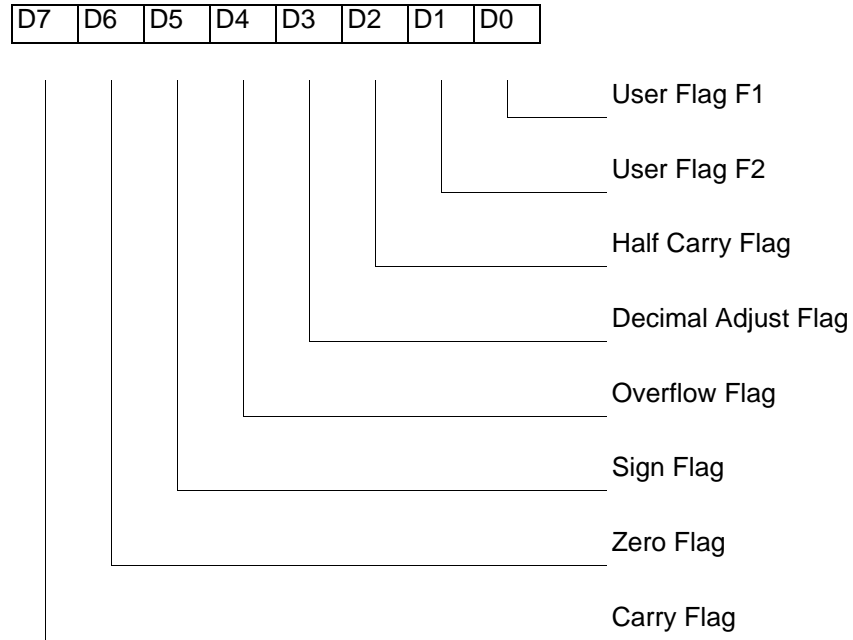
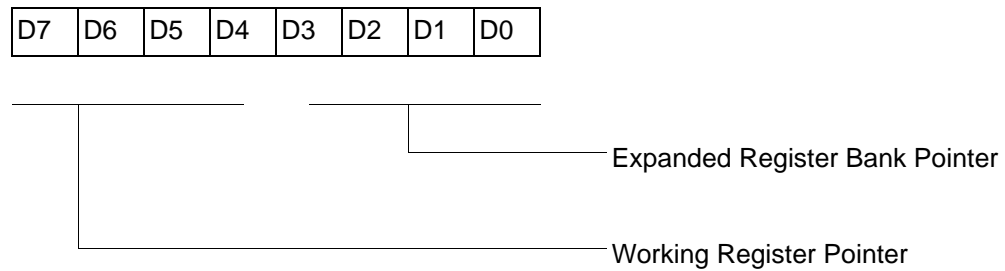

Figure 49. Flag Register (FCH: Read/Write)

R253 RP (FDH)



Default setting after reset = 0000 0000

Figure 50. Register Pointer (FDH: Read/Write)



R254 SPH (FEH)

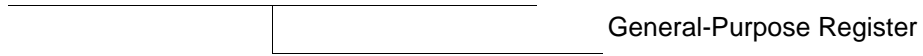
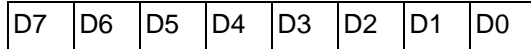

Figure 51. Stack Pointer High (FEH: Read/Write)

R255 SPL (FFH)

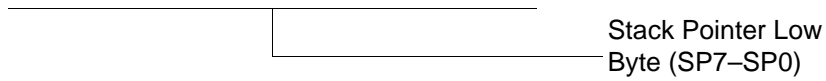
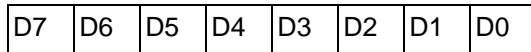

Figure 52. Stack Pointer Low (FFH: Read/Write)



Electrical Characteristics

Absolute Maximum Ratings

A stress greater than listed in Table 16 may or may not cause permanent damage to the device. Functional operation of the device at any condition above those indicated in the operational sections of these specifications is not implied. Exposure to absolute maximum rating conditions for an extended period affects device reliability.

Table 16. Absolute Maximum Ratings

Parameter	Minimum Stress	Maximum Stress	Units	Notes
Ambient temperature under bias	0	+70	C	
Storage temperature	-65	+150	C	
Voltage on any pin with respect to V_{SS}	-0.3	+4.0	V	1
Voltage on V_{DD} pin with respect to V_{SS}	-0.3	+3.6	V	
Maximum current on input and/or inactive output pin	-5	+5	mA	
Maximum output current from active output pin	-25	+25	mA	
Maximum current into V_{DD} or out of V_{SS}		75	mA	

¹This voltage applies to all pins except V_{DD} .



Standard Test Conditions

The characteristics listed in this product specification apply for standard test conditions. All voltages are referenced to GND. Positive current flows into the referenced pin (see Figure 53).

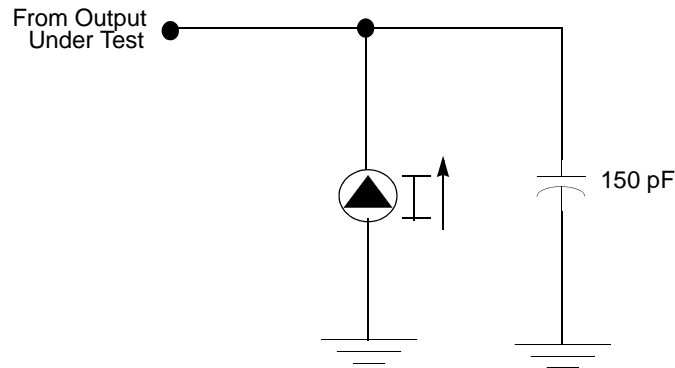

Figure 53. Test Load Diagram

DC Characteristics

Table 17. DC Characteristics

T _A = 0 °C to +70 °C								
Symbol	Parameter	V _{CC}	Minimum	Typ(7)	Maximum	Units	Conditions	Notes
V _{CC}	Supply Voltage		2.0 V		3.6	V	See note 5	
V _{CH}	Clock Input High Voltage	2.0–3.6 V	0.8 V _{CC}		V _{CC} +0.3	V	Driven by External Clock Generator	
V _{CL}	Clock Input Low Voltage	2.0–3.6 V	V _{SS} -0.3		0.5	V	Driven by External Clock Generator	
V _{IH}	Input High Voltage	2.0–3.6 V	0.7 V _{CC}		V _{CC} +0.3	V		
V _{IL}	Input Low Voltage	2.0–3.6 V	V _{SS} -0.3		0.2 V _{CC}	V		
V _{OH1}	Output High Voltage	2.0–3.6 V	V _{CC} -0.4			V	I _{OH} = -0.5 mA	
V _{OH2}	Output High Voltage (P36, P37, P00, P01)	2.0–3.6 V	V _{CC} -0.8			V	I _{OH} = -7 mA	
V _{OL1}	Output Low Voltage	2.0–3.6 V			0.4	V	I _{OL} = 4.0 mA	
V _{OL2}	Output Low Voltage (P00, P01, P36, P37)	2.0–3.6 V			0.8	V	I _{OL} = 10 mA	



Table 17. DC Characteristics (Continued)

T _A = 0 °C to +70 °C								
Symbol	Parameter	V _{CC}	Minimum	Typ(7)	Maximum	Units	Conditions	Notes
V _{OFFSE} T	Comparator Input Offset Voltage	2.0–3.6 V			25	mV		
V _{REF}	Comparator Reference Voltage	2.0–3.6 V	0		V _{DD} -1.75	V		
I _{IL}	Input Leakage	2.0–3.6 V	-1		1	μA	V _{IN} = 0V, V _{CC} Pull-ups disabled	
R _{PU}	Pull-up Resistance	2.0 V	225		675	kΩ	V _{IN} = 0V; Pullups selected by mask option	
		3.6 V	75		275	kΩ		
I _{OL}	Output Leakage	2.0–3.6 V	-1		1	μA	V _{IN} = 0V, V _{CC}	
I _{CC}	Supply Current	2.0 V		1.2	3	mA	at 8.0 MHz	1, 2
		3.6 V		2.1	5	mA	at 8.0 MHz	1, 2
I _{CC1}	Standby Current (HALT Mode)	2.0 V		0.5	1.6	mA	V _{IN} = 0V, Clock at 8.0 MHz Same as above	1, 2, 6 1, 2, 6
		3.6 V		0.8	2.0	mA		
I _{CC2}	Standby Current (STOP Mode)	2.0 V		1.2	8	μA	V _{IN} = 0 V, V _{CC} WDT is not Running Same as above V _{IN} = 0 V, V _{CC} WDT is Running Same as above	3 3 3 3
		3.6 V		1.4	10	μA		
		2.0 V		3.5	20	μA		
		3.6 V		6.5	30	μA		
I _{LV}	Standby Current (Low Voltage)			0.8	6	μA	Measured at 1.3 V	4
V _{BO}	V _{CC} Low Voltage Protection			1.8	2.0	V	8 MHz maximum Ext. CLK Freq.	
V _{LVD}	V _{CC} Low-Voltage Detection			2.4		V		
V _{HVD}	V _{CC} High-Voltage Detection			2.7		V		

Notes

1. All outputs unloaded, inputs at rail.
2. CL1 = CL2 = 100 pF.
3. Oscillator stopped.
4. Oscillator stops when V_{CC} falls below V_{BO} limit.
5. It is strongly recommended to add a filter capacitor (minimum 0.1 μF), physically close to VDD and V_{SS} pins if operating voltage fluctuations are anticipated, such as those resulting from driving an IR LED.
6. Comparators and Timers are On. Interrupt disabled.
7. Typical values shown are at 25 °C.

AC Characteristics

Figure 54 and Table 18 on page 75 describe the alternating current (AC) characteristics.

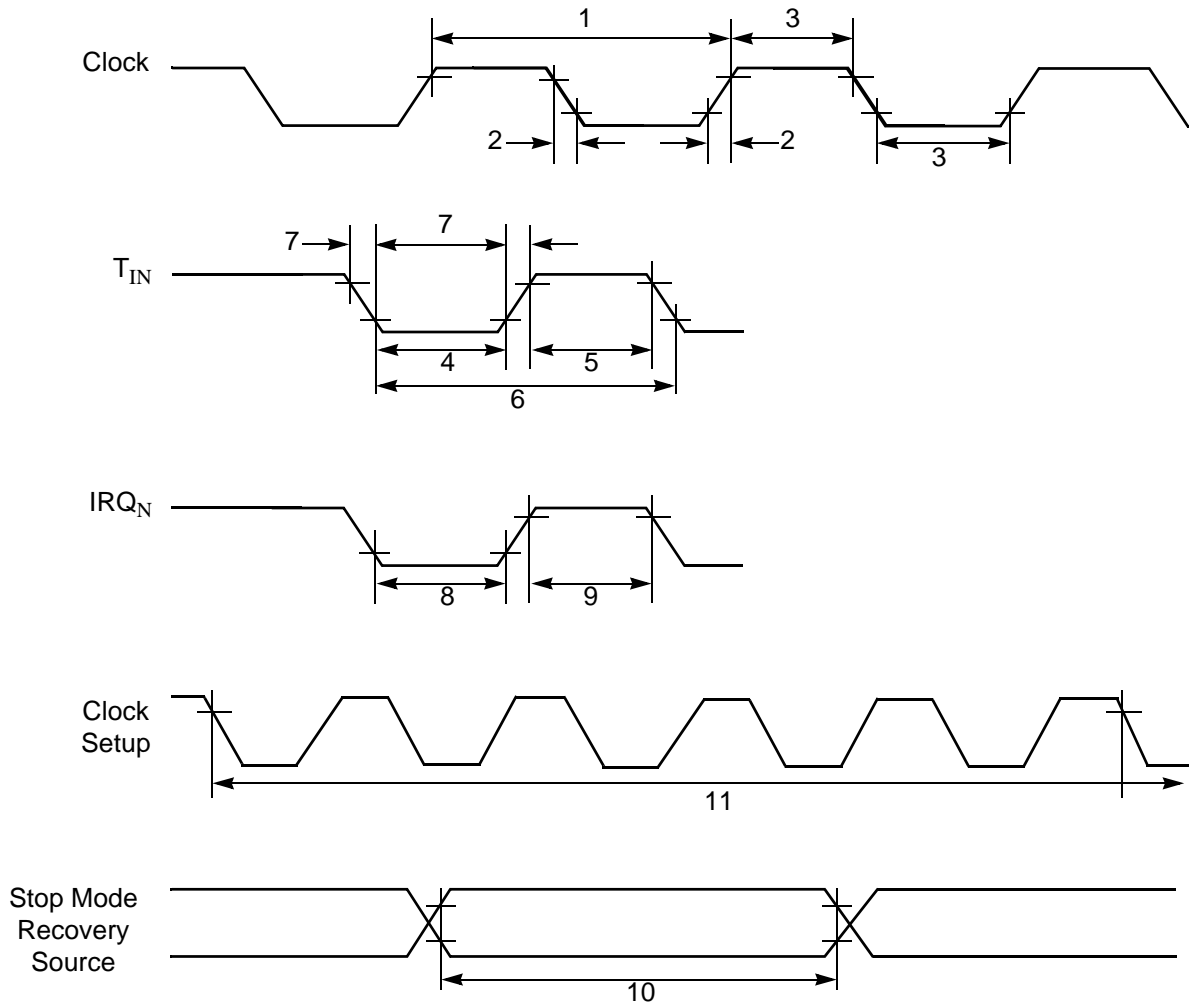

Figure 54. AC Timing Diagram



Table 18. AC Characteristics

T _A =0 °C to +70 °C 8.0 MHz								
No	Symbol	Parameter	V _{CC}	Minimum	Maximum	Units	Notes	Watchdog Timer Mode Register (D1, D0)
1	TpC	Input Clock Period	2.0–3.6	121	DC	ns	1	
2	TrC, TfC	Clock Input Rise and Fall Times	2.0–3.6		25	ns	1	
3	TwC	Input Clock Width	2.0–3.6	37		ns	1	
4	TwTinL	Timer Input Low Width	2.0 3.6	100 70		ns	1	
5	TwTinH	Timer Input High Width	2.0–3.6	3TpC			1	
6	TpTin	Timer Input Period	2.0–3.6	8TpC			1	
7	TrTin, TfTin	Timer Input Rise and Fall Timers	2.0–3.6		100	ns	1	
8	TwIL	Interrupt Request Low Time	2.0 3.6	100 70		ns	1, 2	
9	TwIH	Interrupt Request Input High Time	2.0–3.6	10TpC			1, 2	
10	Twsm	Stop Mode Recovery Width Spec	2.0–3.6	12 10TpC		ns	3 4	
11	Tost	Oscillator Start-Up Time	2.0–3.6		5TpC		4	
12	Twdt	Watchdog Timer Delay Time	2.0–3.6 2.0–3.6 2.0–3.6 2.0–3.6	10 20 40 160		ms ms ms ms		0, 0 0, 1 1, 0 1, 1
13	T _{POR}	Power-On Reset	2.0–3.6	2.5	10	ms		

Notes

1. Timing Reference uses 0.9 V_{CC} for a logic 1 and 0.1 V_{CC} for a logic 0.
2. Interrupt request through Port 3 (P33–P31).
3. SMR – D5 = 1.
4. SMR – D5 = 0.



Capacitance

Table 19 lists the capacitances.

Table 19. Capacitance

Parameter	Maximum
Input capacitance	12 pF
Output capacitance	12 pF
I/O capacitance	12 pF

Note: $T_A = 25\text{ }^\circ\text{C}$, $V_{CC} = \text{GND} = 0\text{ V}$, $f = 1.0\text{ MHz}$, unmeasured pins returned to GND.



Packaging

Figure 55 through Figure 60 on page 84 display package information available for all the Crimzon ZLR16300 device versions.

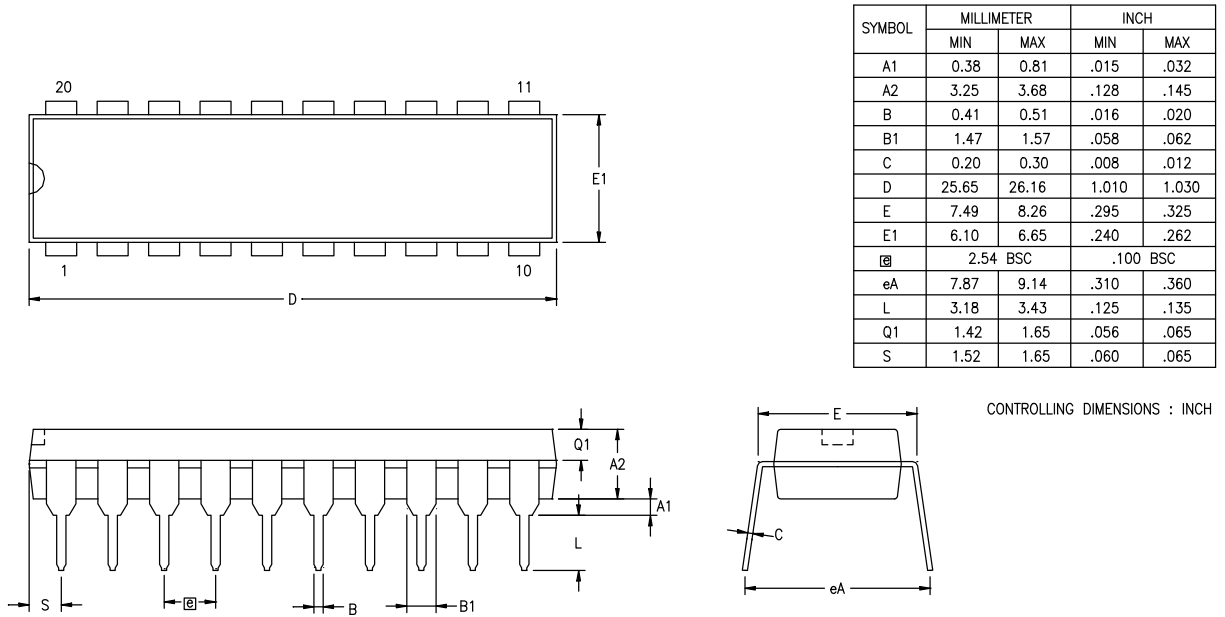

Figure 55. 20-Pin DIP Package Diagram

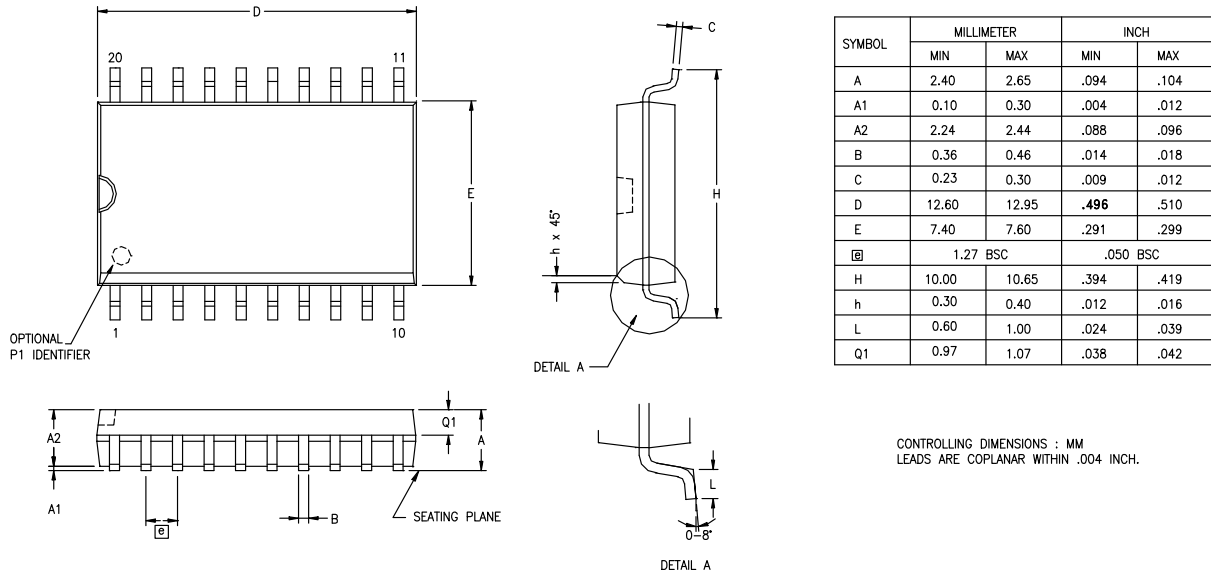

Figure 56. 20-Pin SOIC Package Diagram

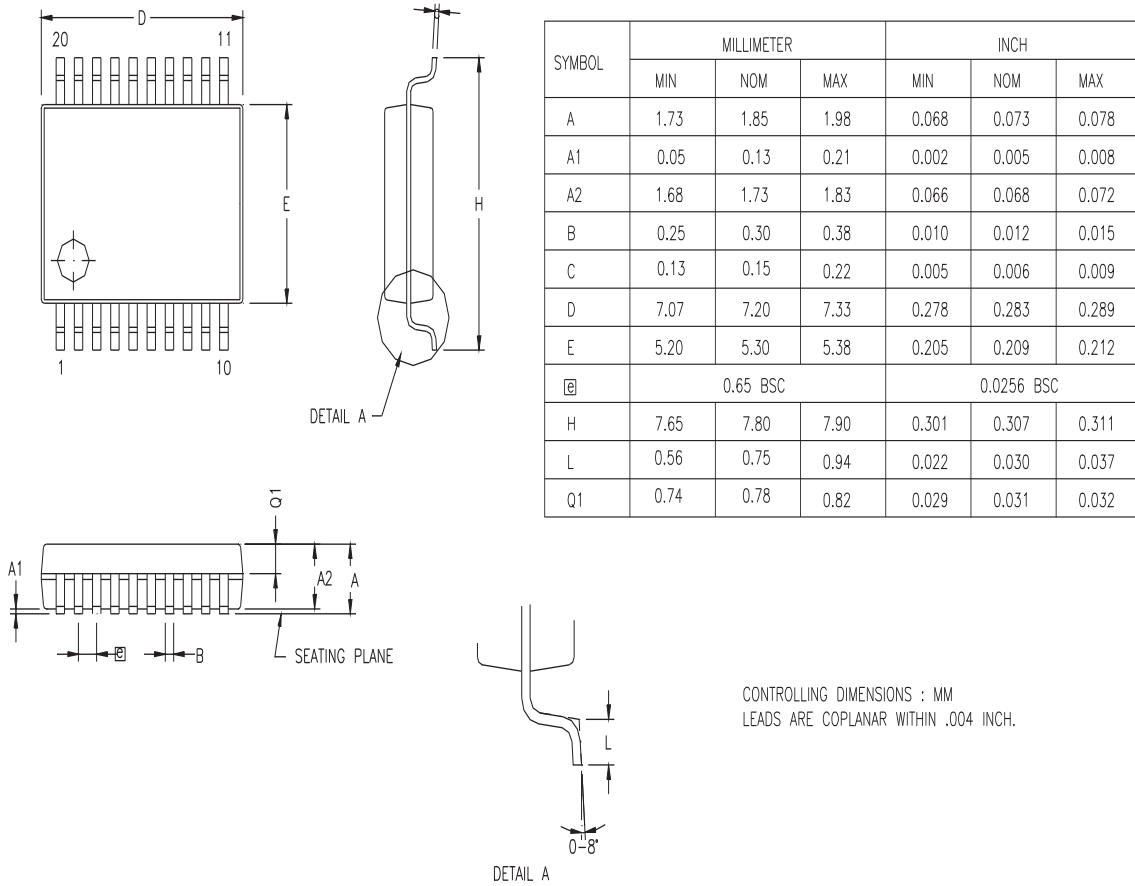
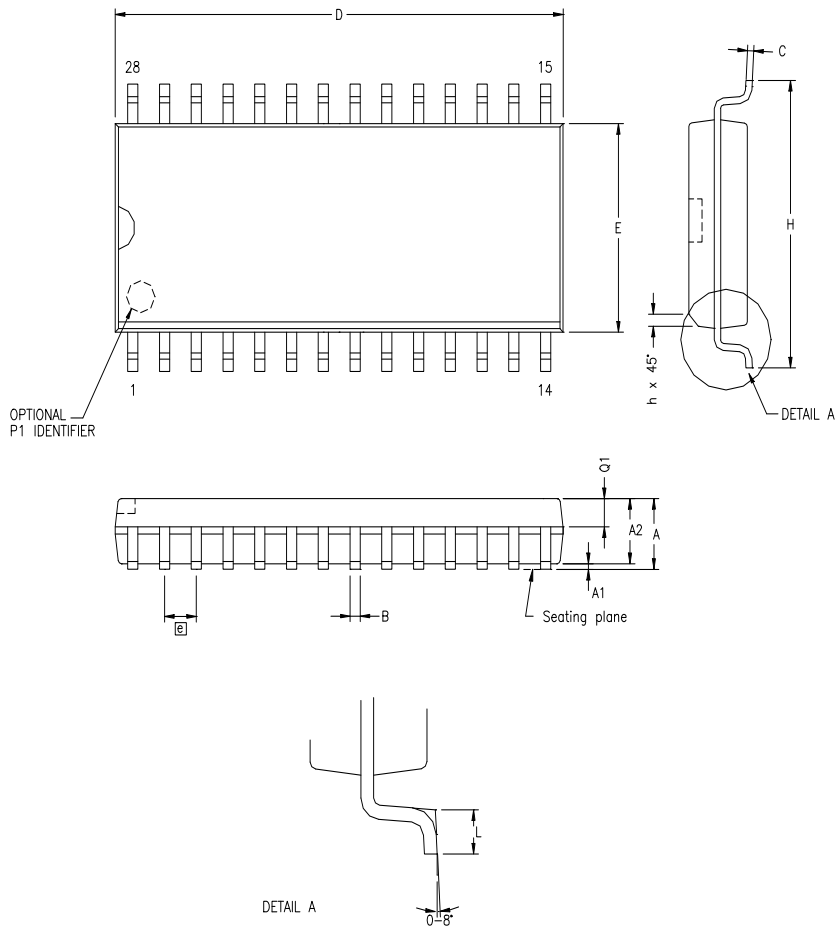

Figure 57. 20-Pin SSOP Package Diagram



SYMBOL	MILLIMETER		INCH	
	MIN	MAX	MIN	MAX
A	2.40	2.64	.094	.104
A1	0.10	0.30	.004	.012
A2	2.24	2.44	.088	.096
B	0.36	0.46	.014	.018
C	0.23	0.30	.009	.012
D	17.78	18.00	.700	.710
E	7.40	7.60	.291	.299
Ⓜ	1.27 BSC		.050 BSC	
H	10.00	10.65	.394	.419
h	0.30	0.71	.012	.028
L	0.61	1.00	.024	.039
Q1	0.97	1.09	.038	.043

CONTROLLING DIMENSIONS : MM
LEADS ARE COPLANAR WITHIN .004 INCH.

Figure 58. 28-Pin SOIC Package Diagram

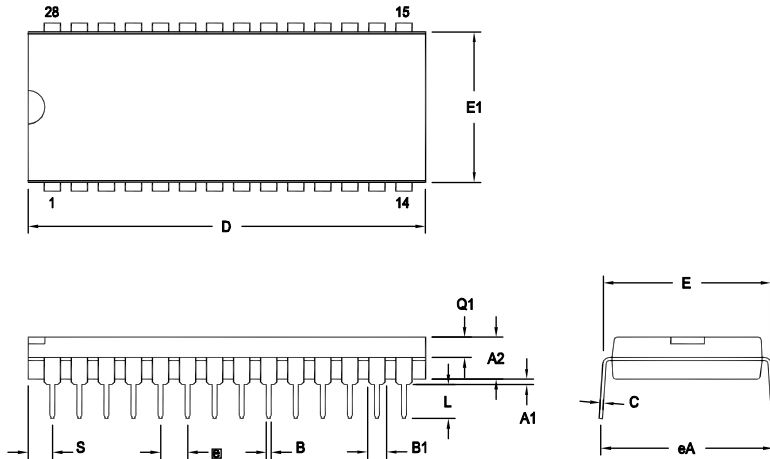

SYMBOL	OPT #	MILLIMETER		INCH	
		MIN	MAX	MIN	MAX
A1		0.38	1.02	.015	.040
A2		3.18	4.19	.125	.165
B		0.38	0.53	.015	.021
B1	01	1.40	1.65	.055	.065
	02	1.14	1.40	.045	.055
C		0.23	0.38	.009	.015
D	01	36.58	37.34	1.440	1.470
	02	35.31	35.94	1.390	1.415
E		15.24	15.75	.600	.620
E1	01	13.59	14.10	.535	.555
	02	12.83	13.08	.505	.515
e		2.54 TYP		.100 BSC	
eA		15.49	16.76	.610	.660
L		3.05	3.81	.120	.150
Q1	01	1.40	1.91	.055	.075
	02	1.40	1.78	.055	.070
S	01	1.52	2.29	.060	.090
	02	1.02	1.52	.040	.060

CONTROLLING DIMENSIONS : INCH

OPTION TABLE	
OPTION #	PACKAGE
01	STANDARD
02	IDF

Note: ZILOG supplies both options for production. Component layout PCB design should cover bigger option 01.

Figure 59. 28-Pin DIP Package Diagram

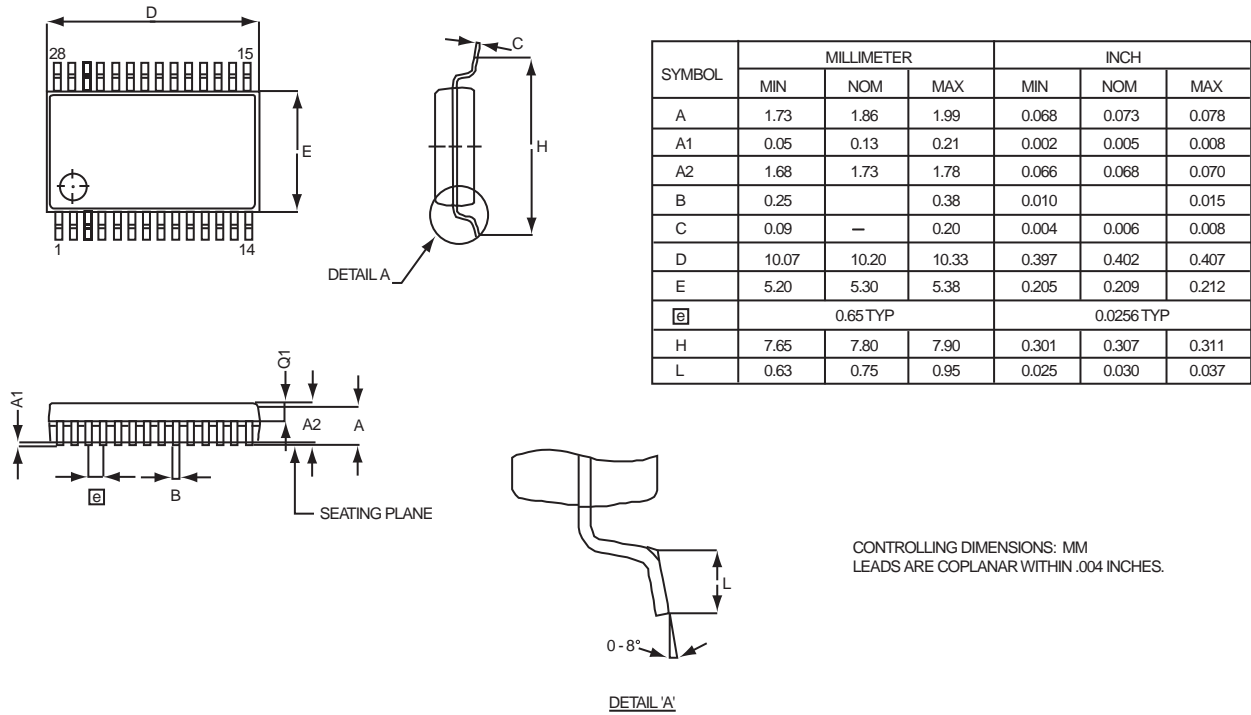

Figure 60. 28-Pin SSOP Package Diagram

► **Note:** Contact Maxim for the actual bonding diagram and chip-on-board assembly.



Ordering Information

The Crimzon ZLR16300 is available for 16K, 8K, 4K, 2K, and 1K parts.

Memory Size	Part Number	Description
16K	ZLR16300H2816G	28-pin SSOP 16 K ROM
	ZLR16300P2816G	28-pin PDIP 16 K ROM
	ZLR16300S2816G	28-pin SOIC 16 K ROM
	ZLR16300H2016G	20-pin SSOP 16 K ROM
	ZLR16300P2016G	20-pin PDIP 16 K ROM
	ZLR16300S2016G	20-pin SOIC 16 K ROM
8K	ZLR16300H2808G	28-pin SSOP 8 K ROM
	ZLR16300P2808G	28-pin PDIP 8 K ROM
	ZLR16300S2808G	28-pin SOIC 8 K ROM
	ZLR16300H2008G	20-pin SSOP 8 K ROM
	ZLR16300P2008G	20-pin PDIP 8 K ROM
	ZLR16300S2008G	20-pin SOIC 8 K ROM
4K	ZLR16300H2804G	28-pin SSOP 4 K ROM
	ZLR16300P2804G	28-pin PDIP 4 K ROM
	ZLR16300S2804G	28-pin SOIC 4 K ROM
	ZLR16300H2004G	20-pin SSOP 4 K ROM
	ZLR16300P2004G	20-pin PDIP 4 K ROM
	ZLR16300S2004G	20-pin SOIC 4 K ROM
2K	ZLR16300H2802G	28-pin SSOP 2 K ROM
	ZLR16300P2802G	28-pin PDIP 2 K ROM
	ZLR16300S2802G	28-pin SOIC 2 K ROM
	ZLR16300H2002G	20-pin SSOP 2 K ROM
	ZLR16300P2002G	20-pin PDIP 2 K ROM
	ZLR16300S2002G	20-pin SOIC 2 K ROM
1K	ZLR16300H2801G	28-pin SSOP 1 K ROM
	ZLR16300P2801G	28-pin PDIP 1 K ROM
	ZLR16300S2801G	28-pin SOIC 1 K ROM
	ZLR16300H2001G	20-pin SSOP 1 K ROM
	ZLR16300P2001G	20-pin PDIP 1 K ROM



Memory Size	Part Number	Description
	ZLR16300S2001G	20-pin SOIC 1 K ROM
Development Tools		
	ZLP128ICE01ZEMG*	In-Circuit Emulator
Note: *ZLP128ICE01ZEMG has been replaced by an improved version, ZCRMZNICE01ZEMG.		
	ZCRMZNICE01ZEMG	Crimzon In-Circuit Emulator
	ZCRMZN00100KITG	Crimzon In-Circuit Emulator Development Kit
	ZCRMZNICE01ZACG	20-Pin Accessory Kit
	ZCRMZNICE02ZACG	40/48-Pin Accessory Kit

Note: Contact www.maxim-ic.com for the die form.

For faster results, contact your local Maxim sales office for assistance in ordering the part(s) required.



Part Number Description

Maxim part numbers consist of a number of components as shown below. For example, part number ZLR16300H2816G is a Crimzon masked ROM product in a 28-pin SSOP package, with 16 KB of ROM and built with lead-free solder.

Z LR 16300 H 28 16 G

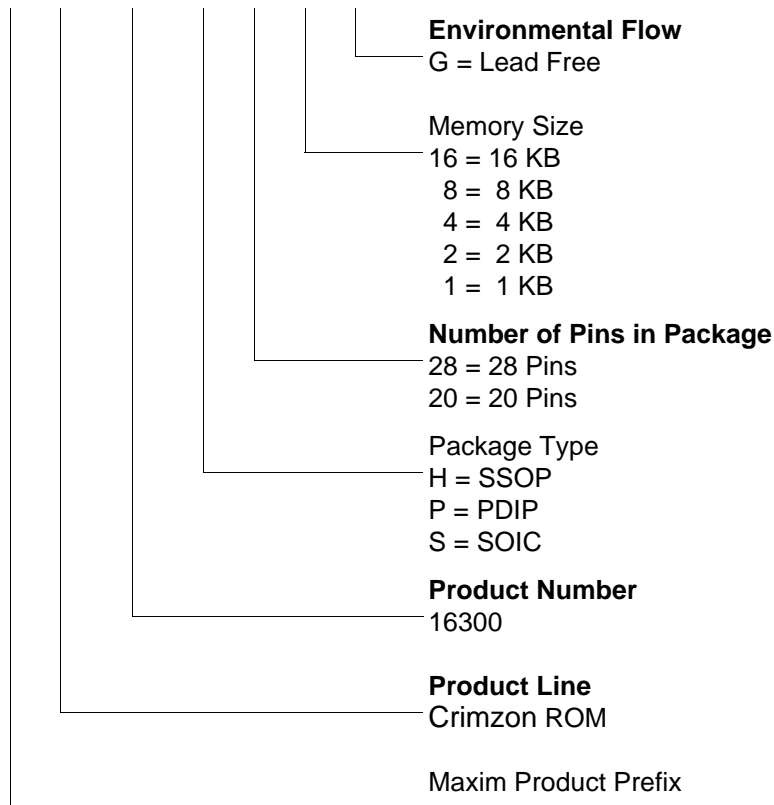



Index

Numerics

16-bit counter/timer circuits 36
20-pin DIP package diagram 79
20-pin SSOP package diagram 81
28-pin DIP package diagram 83
28-pin SOIC package diagram 82
28-pin SSOP package diagram 84
8-bit counter/timer circuits 32

A

AC

timing diagram 75
address spaces, basic 1
architecture 1
expanded register file 18

B

basic address spaces 1
Block Diagram 1, 3
block diagram, ZLR16300 functional 3

C

capture_INT_mask 24, 28
clock 43
comparator inputs/outputs 13
configuration
port 0 8
port 2 9
port 3 10
port 3 counter/timer 12
counter/timer
16-bit circuits 36
8-bit circuits 32
brown-out voltage/standby 54
clock 43
demodulation mode count capture flowchart 34

demodulation mode flowchart 35
EPROM selectable options 54
glitch filter circuitry 30
halt instruction 44
input circuit 29
interrupt block diagram 41
interrupt types, sources and vectors 42
oscillator configuration 43
output circuit 39
ping-pong mode 38
port configuration register 45
resets and WDT 53
SCLK circuit 47
stop instruction 44
stop mode recovery register 46
stop mode recovery register 2 49, 50
stop mode recovery source 48
T16 demodulation mode 37
T16 transmit mode 36
T16_OUT in modulo-N mode 37
T16_OUT in single-pass mode 37
T8 demodulation mode 33
T8 transmit mode 30
T8_OUT in modulo-N mode 33
T8_OUT in single-pass mode 33
transmit mode flowchart 31
voltage detection and flags 55
watchdog timer mode register 51
watchdog timer time select 52
counter/timer functional blocks
input circuit 29
T8 transmit mode 30
counter_INT_mask 28
crt3 T8/T16 control register
register 28
CTR(D)01h T8 and T16 common functions 25
CTR1 (0D)01 24
CTR3 T8/T16 control CTR3(0D)03h 28

D

demodulation mode
count capture flowchart 34
flowchart 35



T16 37
T8 33
description
functional 15

E

EPROM
selectable options 54
expanded register file 17
expanded register file architecture 18
expanded register file control registers 60
flag 68
interrupt mask register 67
interrupt priority register 66
interrupt request register 67
port 0 and 1 mode register 65
port 2 configuration register 64
port 3 mode register 65
port configuration register 64
register pointer 68
stack pointer high register 69
stack pointer low register 69
stop mode recovery register 62
stop mode recovery register 2 63
T16 control register 59
T8 and T16 common control functions register 58
TC8 control register 55
watch-dog timer register 64

F

features
standby modes 2
ZLR16300 1
functional description
counter/timer functional blocks 29
CTR0(0D)00h register 23
CTR1(0D)01h register 24
CTR2(0D)02h register 27
expanded register file 17
expanded register file architecture 18
HI16(0D)09h register 22

HI8(0D)0Bh register 21
LO8(0D)0Ah register 22
LOI6(0D)08h register 22
program memory map 16
RAM 16
register description 54
register file 20
register pointer 19
register pointer detail 21
stack 21
TC16H(0D)07h register 22
TC16L(0D)06h register 22
TC8H(0D)05h register 23
TC8L(0D)04h register 23
TC8L(D)04h register 23

G

glitch filter circuitry 29, 30

H

halt instruction, counter/timer 44

I

input circuit 29
interrupt block diagram, counter/timer 41
interrupt types, sources and vectors 42

L

low-voltage detection register 54

M

memory, program 15
modulo-N mode
T16_OUT 37
T8_OUT 33

**O**

oscillator configuration 43
output circuit, counter/timer 39

P

P34_out 24
P35_out 28
P36_out/demodulator input 26
package information
 20-pin DIP package diagram 79
 20-pin SSOP package diagram 81
 28-pin DIP package diagram 83
 28-pin SOIC package diagram 82
 28-pin SSOP package diagram 84
part number format 87
pin configuration
 20-pin DIP/SOIC/SSOP 5
 28-pin DIP/SOIC/SSOP 6
Pin Descriptions 5
pin functions
 port 0 (P07 - P00) 8
 port 0 configuration 8
 port 2 (P27 - P20) 9
 port 2 (P37 - P30) 10
 port 2 configuration 9
 port 3 configuration 10
 port 3 counter/timer configuration 12
 XTAL1 (time-based input) 7
 XTAL2 (time-based output) 7
ping-pong mode 38
port 0
 configuration 8
 pin function 8
port 2
 configuration 9
 pin function 9
port 3
 configuration 10
 counter/timer configuration 12
port 3 pin function 10
port configuration register 45
power connections 2
power supply 5

Precharacterization Product 86
program memory 15
 map 16

R

register 50
 CTR0(0D)00h 23
 CTR1 (0D) 01 24
 CTR1(0D)01h 24
 CTR2(0D)02h 27
 flag 68
 HI16(0D)09h 22
 HI8(0D)0Bh 21
 interrupt priority 66
 interrupt request 67
 interruptmask 67
 L016(0D)08h 22
 L08(0D)0Ah 22
 LVD(D)0Ch 54
 pointer 68
 port 0 and 1 65
 port 2 configuration 64
 port 3 mode 65
 port configuration 45, 64
 stack pointer high 69
 stack pointer low 69
 stop mode recovery 46
 stop mode recovery 2 49
 stop mode recovery 62
 stop mode recovery 2 63
 T16 control 59
 T8 and T16 common control functions 58
 TC16H(0D)07h 22
 TC16L(0D)06h 22
 TC8 control 55
 TC8H(0D)05h 23
 TC8L(0D)04h 23
 TC8L(D)04h 23
 voltage detection 60
 watch-dog timer 64
register description
 counter/timer2 LS-Byte hold 22
 counter/timer2 MS-Byte hold 22



- counter/timer8 control 23
- counter/timer8 High hold 23
- counter/timer8 Low hold 23
- CTR2 counter/timer 16 control 27
- T16_capture_LO 22
- T8 and T16 common functions 24
- T8_Capture_HI 21
- T8_capture_LO 22
- register file 20
 - expanded 17
- register pointer 19
 - detail 21
- resets and WDT 53

S

- SCLK circuit 47
- single/modulo-N 24, 28
- single-pass mode
 - T16_OUT 37
 - T8_OUT 33
- stack 21
- standby modes 2
- stop instruction, counter/timer 44
- stop mode recovery
 - 2 register 49
 - source 48
- stop mode recovery 2 50
- stop mode recovery register 46

T

- T 16 clock 28
- T16 enable 28
- T16 initial out/falling edge 27
- T16 transmit mode 36
- T16_capture_HI 22
- T8 and T16 common functions 24
- t8 clock 24
- T8 enable 24
- T8 initial out/rising edge 27
- T8 transmit mode 30
- T8/T16_logic/edge_detect 26
- T8_Capture_HI 21

- test load diagram 72
- time_out 28
- timeout 24
- timers
 - counter/timer2 LS-byte hold 22
 - counter/timer2 MS-byte hold 22
 - counter/timer8 high hold 23
 - counter/timer8 low hold 23
 - CTR0 counter/timer8 control 23
 - T16_Capture_HI 22
 - T16_Capture_LO 22
 - T8_Capture_HI 21
 - T8_Capture_LO 22
- timing diagram, AC 75
- transmit mode flowchart 31
- transmit_submode/glitch filter 26

V

- VCC 5
- voltage
 - brown-out/standby 54
 - detection and flags 55
- voltage detection register 60

W

- watchdog timer
 - mode register watchdog timer mode register 51
 - time select 52

X

- XTAL1 5
- XTAL1 pin function 7
- XTAL2 5
- XTAL2 pin function 7

Z

- ZLR16300 family members 1



Customer Support

For any comments, detail technical questions, or reporting problems, please visit Maxim's Technical Support at <https://support.maxim-ic.com/micro>.