

Schematic(LOWER ROW&UPPER ROW):

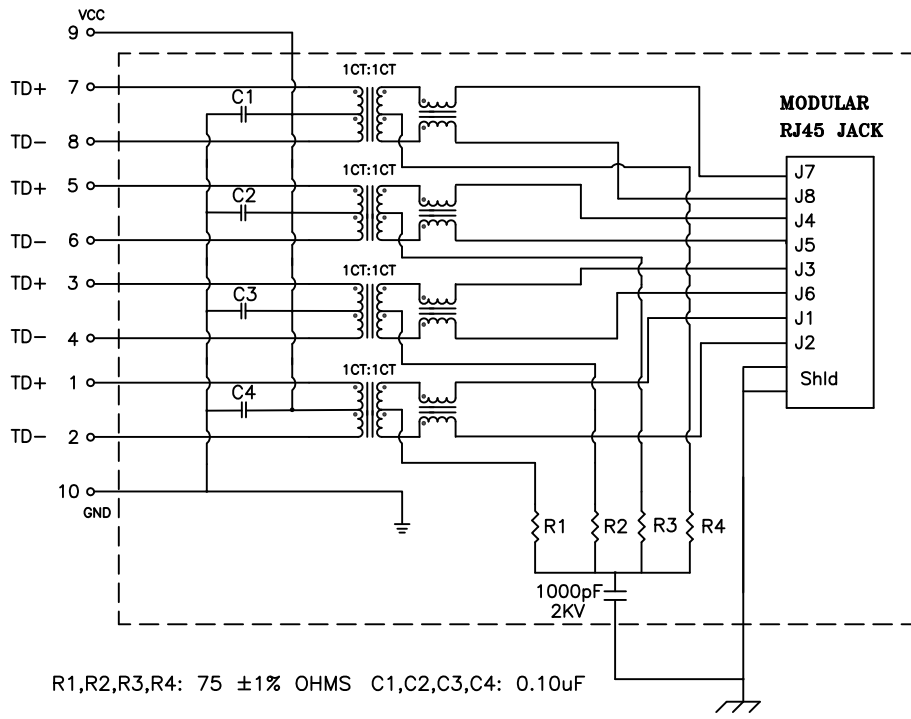

Electrical Specifications: @25°C

ISOLATION: 1500 Vrms
 TURNS RATIO: (PRI/SEC) 1CT:1CT ±2%
 OCL: 350uH MIN @100KHz 100mV 8mADC
 Rise Time: 1.75ns Max.
 INSERTION LOSS: -1.0dB MAX @1-100MHZ
 RETURN LOSS: -18dB Min @1-30MHz
 -14dB Min @30-60MHz
 -12dB Min @60-80MHz
 Differential to Common Mode Rejection:
 -30dB Typ @1-50MHz
 -20dB Typ @50-150MHz
 CMRR: -30dB Min @1-100MHz
 Crosstalk: -40dB Typ @1-30MHz
 -35dB Typ @30-60MHz
 -30dB Typ @60-80MHz
 Q: 5 Min @100KHz 100mV

Notes:

1. Solderability: Leads shall meet MIL-STD-202G, Method 208H for solderability.
2. Flammability: UL94V-0
3. ASTM oxygen index: > 28%
4. UL Recognized Component: File Number E165866
5. Operating Temperature Range: All listed parameters are to be within tolerance from -40°C to +85°C
6. Storage Temperature Range: -55°C to +125°C
7. Aqueous wash compatible
8. Electrical and mechanical specifications 100% tested
9. RoHS Compliant Component

DOC REV.: A/3

| | | | |
|------------------------------------|---|----------------------|-----------|
| XFMRs Inc. www.XFMRs.com | Title: 2X1 Gigabit Stacked Combo with dual Rows W/O LED | | |
| | UNLESS OTHERWISE SPECIFIED TOLERANCES: .xxx ±0.010 | P/N: XFGIGH-STKVD2-4 | REV. A |
| Dimensions in Inch | DWN. | Yuan | Mar-05-14 |
| SHEET 1 OF 2 | CHK. | YK Liao | Mar-05-14 |
| | APP. | DDC | Mar-05-14 |

PROPRIETARY:

Document is the property of XFMRs Group & is not allowed to be duplicated without authorization.

Mechanical Dimensions:

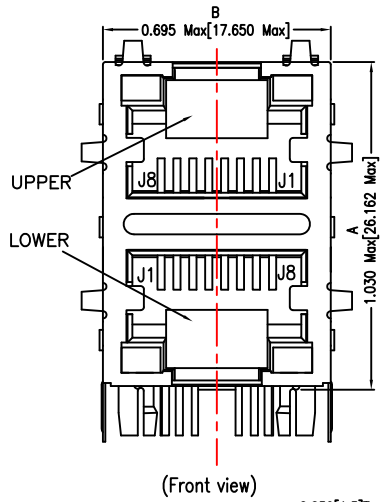

(Front view)

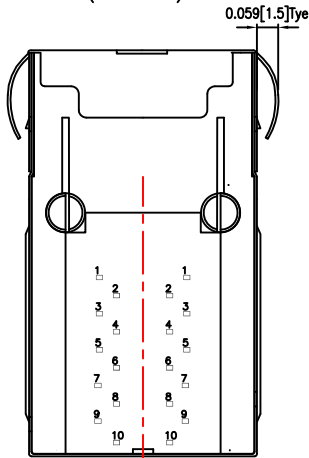

(Bottom view)

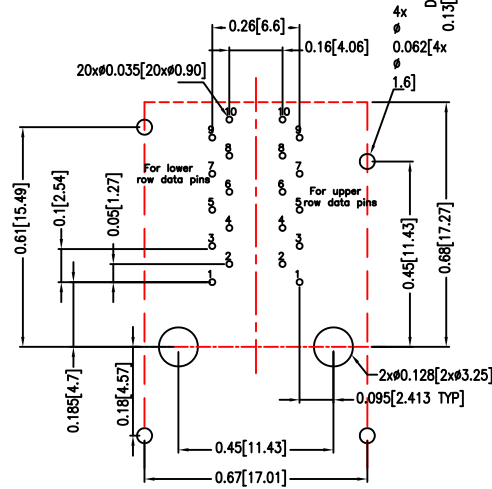
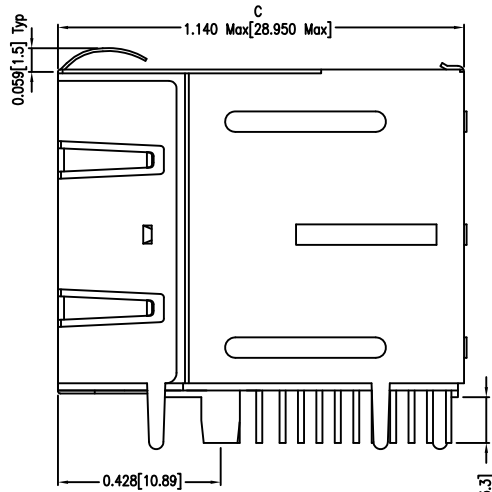

P.C.B RECOMMENDED HOLE LAYOUT
SEEN FROM COMPONENT SIDE

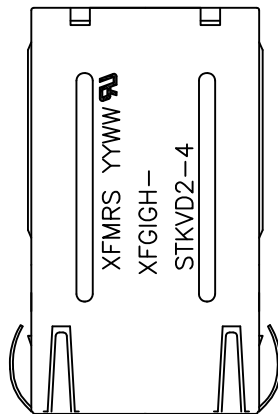

(Top view)

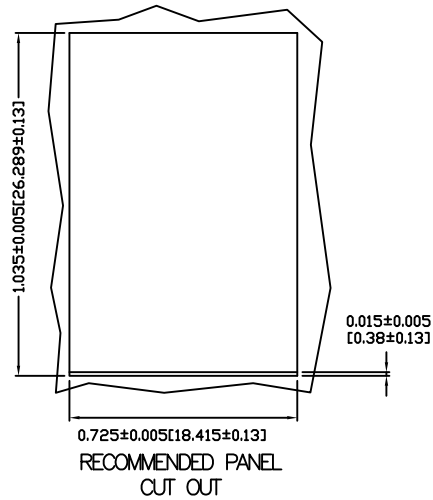

RECOMMENDED PANEL
CUT OUT

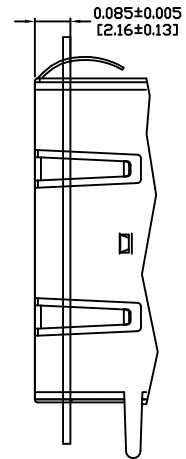

TO TOP OF PCB

XFMRS Inc.
www.XFMRS.com

Title: Mechanical Dimensions For 2x1
Stacked COMBO with Vertical Dual lines Pins

UNLESS OTHERWISE SPECIFIED
TOLERANCES:

P/N: XFGIGH-STKVD2-4

REV. A

.xxx ±0.010 [±0.25]
Dimensions in Inch [mm]

DWN.

Yuan

Mar-05-14

CHK.

YK Liao

Mar-05-14

SHEET 2 OF 2

APP.

DDC

Mar-05-14

DOC REV: A/3

PROPRIETARY

Document is the property of XFMRS Group & is not allowed to be duplicated without authorization.