

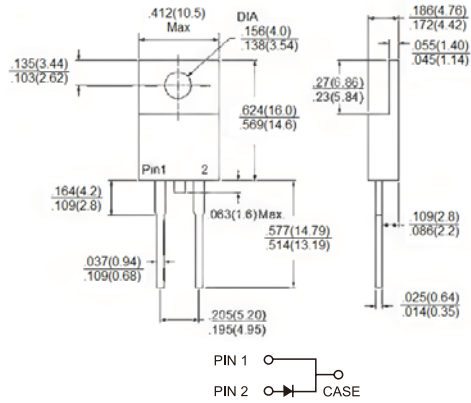

MBR1635 - MBR16150

16.0 AMPS. Schottky Barrier Rectifiers

TO-220AC



Dimensions in inches and (millimeters)

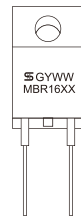

Marking Diagram

MBR16XX = Specific Device Code
 G = Green Compound
 Y = Year
 WW = Work Week

Features

- ✧ UL Recognized File # E-326243
- ✧ Plastic material used carries Underwriters Laboratory Classifications 94V-0
- ✧ Metal silicon junction, majority carrier conduction
- ✧ Low power loss, high efficiency
- ✧ High current capability, low forward voltage drop
- ✧ High surge capability
- ✧ For use in low voltage, high frequency inverters, free wheeling, and polarity protection applications
- ✧ Guardring for overvoltage protection
- ✧ High temperature soldering guaranteed: 260°C/10 seconds, 0.25"(6.35mm) from case
- ✧ Green compound with suffix "G" on packing code & prefix "G" on datecode.

Mechanical Data

- ✧ Cases: JEDEC TO-220AC molded plastic body
- ✧ Terminals: Pure tin plated, lead free. solderable per MIL-STD-750, Method 2026
- ✧ Polarity: As marked
- ✧ Mounting position: Any
- ✧ Mounting torque: 5 in. - lbs. max
- ✧ Weight: 1.86 grams

Maximum Ratings and Electrical Characteristics

Rating at 25 °C ambient temperature unless otherwise specified.
 Single phase, half wave, 60 Hz, resistive or inductive load.
 For capacitive load, derate current by 20%

Type Number	Symbol	MBR 1635	MBR 1645	MBR 1650	MBR 1660	MBR 1690	MBR 16100	MBR 16150	Units
Maximum Recurrent Peak Reverse Voltage	V_{RRM}	35	45	50	60	90	100	150	V
Maximum RMS Voltage	V_{RMS}	24	31	35	42	63	70	105	V
Maximum DC Blocking Voltage	V_{DC}	35	45	50	60	90	100	150	V
Maximum Average Forward Rectified Current at $T_c=125^\circ C$	$I_{F(AV)}$	16							A
Peak Repetitive Forward Current (Rated V_R , Square Wave, 20KHz) at $T_c=125^\circ C$	I_{FRM}	32							A
Peak Forward Surge Current, 8.3 ms Single Half Sine-wave Superimposed on Rated Load (JEDEC method)	I_{FSM}	150							A
Peak Repetitive Reverse Surge Current (Note 2)	I_{RRM}	1.0	0.5					A	
Maximum Instantaneous Forward Voltage at: $I_F=16A, T_A=25^\circ C$ $I_F=16A, T_A=125^\circ C$	V_F	0.63 0.57	0.75 0.65		0.85 0.75		0.95 0.92	V	
Maximum Instantaneous Reverse Current at Rated DC Blocking Voltage (Note 1) @ $T_A=25^\circ C$ @ $T_A=125^\circ C$	I_R	0.5 15	0.5 10		0.3 7.5		0.1 5	mA mA	
Voltage Rate of Change (Rated V_R)	dV/dt	10,000							V/ μ S
Typical Junction Capacitance	C_j	500							pF
Maximum Typical Thermal Resistance(Note 3)	$R_{\theta JC}$	3.0							$^\circ C/W$
Operating Junction Temperature Range	T_J	-65 to +150							$^\circ C$
Storage Temperature Range	T_{STG}	-65 to +175							$^\circ C$

Notes: 1. Pulse Test: 300us Pulse Width, 1% Duty Cycle
 2. 2.0us Pulse Width, f=1.0 KHz
 3. Mount on Heatsink Size of 2" x 3" x 0.25" Al-Plate.

RATINGS AND CHARACTERISTIC CURVES (MBR1635 THRU MBR16150)

FIG.1- FORWARD CURRENT DERATING CURVE

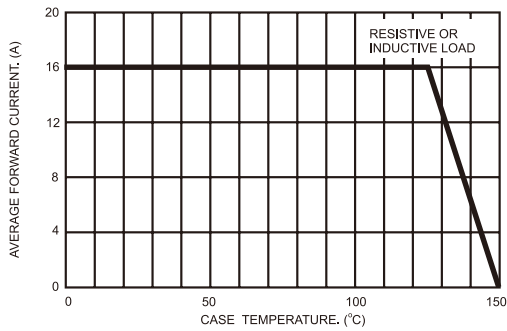

FIG.2- MAXIMUM NON-REPETITIVE FORWARD SURGE CURRENT

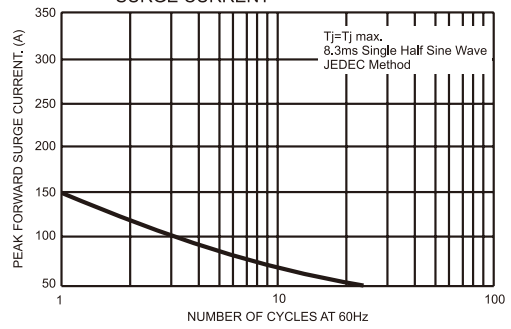

FIG.3- TYPICAL INSTANTANEOUS FORWARD CHARACTERISTICS

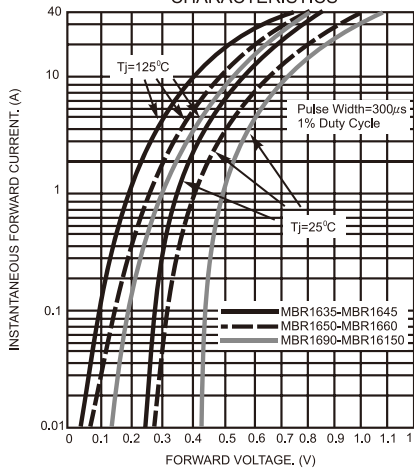

FIG.4- TYPICAL REVERSE CHARACTERISTICS

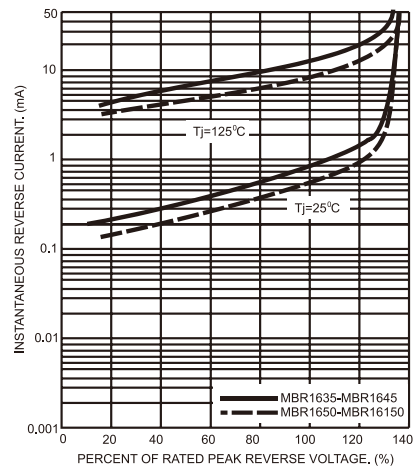

FIG.5- TYPICAL JUNCTION CAPACITANCE

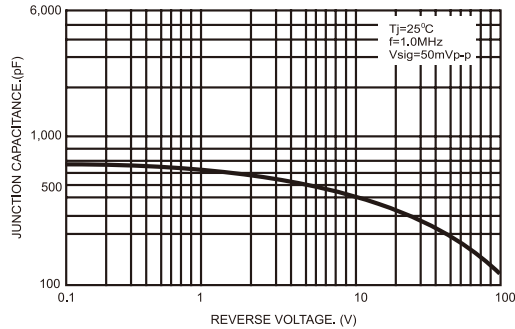

FIG.6- TYPICAL TRANSIENT THERMAL CHARACTERISTICS

