

---

 GPS Ultra High Sensitivity Module
 

---

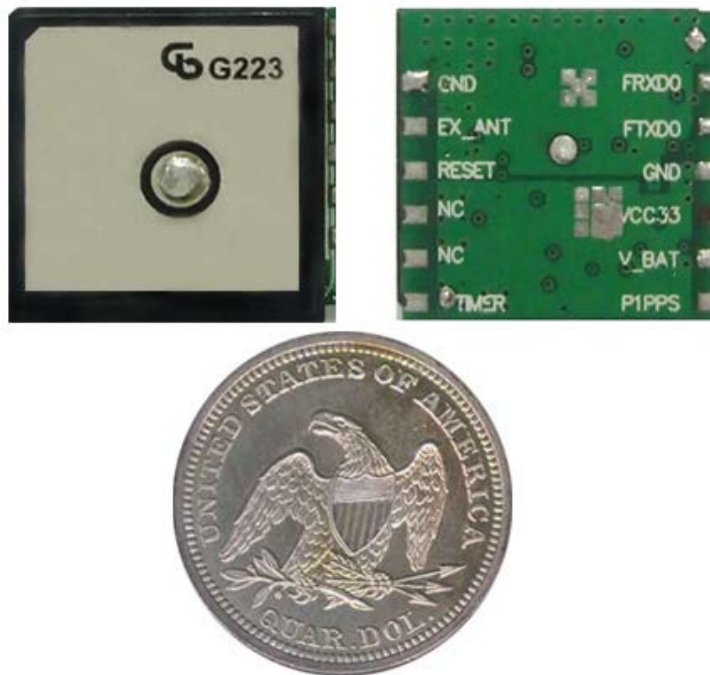

### Key Features

- Support GPS, QZSS, SBAS
- Signal detection better than -165dBm
- Ultra low power operation
- UART
- Open sky hot start 1 second
- Open sky cold start 29 seconds
- Support 7-day AGPS
- embedded Patch Antenna

### Version History

Version	Date	Changes
V1.00	September 2, 2013	1 <sup>st</sup> . Edition

## Applications

LBS (Location Based Service)  
GPS mouse and Bluetooth GPS receiver  
Vehicle position tracking  
Aero model auto-positioning

LBS (Location Based Service)  
GPS mouse and Bluetooth GPS receiver  
車輛追蹤定位  
航模自動飛行定位

## Product Description

GPS-18X19 GPS is a satellite positioning module fully integrated with antenna and receiver. It has ultra-high sensitivity and can be applied to various occasions. Simplified UART output provides the easiness for engineers to do the designing work. It can be utilized along with plug-in IC regulated power supply module. Coming with UART coordinate system, 18X19 GPS Module output can directly connect to MCU or be used for several applications.

GPS-18X19 GPS Module 是完全集成天線和接收之衛星定位模組，超高感度設計，方便應用於不同場合。簡單化 UART 輸出，工程師容易設計，只需簡單外掛穩壓 IC 供電模組便可使用，透過 UART 坐標便可直接輸出接至 MCU 或其他用途。

## Pin Assignments

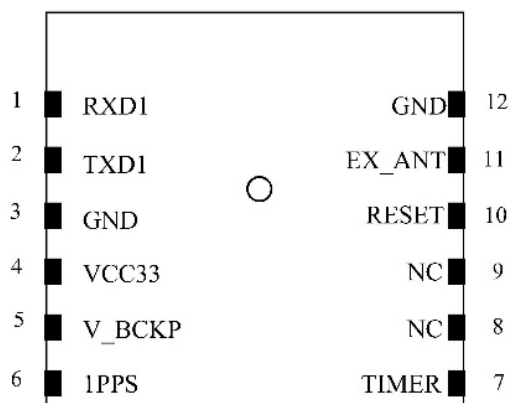

Top View of the Module

## Pin Function

Pin	Name	I/O	Description
1	RXD1	Digital I	Universal Asynchronous Receiver
2	TXD1	Digital O	Universal Asynchronous Receiver
3	GND	GND	Ground.
4	VCC33	Input	+3.3V to +3.6 V Supply Voltage Input to Internal Regulators
5	V BACK	Input	The real-time clock circuitry and a small block of SRAM is included on-chip to retain time and the necessary GPS data for rapid warm start and hot-start operation
5	1PPS	Digital O	1 pulse per second output,
7	TIME		
8	NC		
9	NC		
10	RESET	Digital Input	Module Reset
11	EXT ANT	Input	External active antenna
12	GND	GND	Ground

# Hardware Specification

Conditions: VDD =VCC= 3V3V, VSS = 0V, TA = 25°C

Parameter	Symbol	Test Condition	Min	Typ	Max	Unit
Supply Voltage Range	POWER		3	3.3	3.6	V
Current	Receiver	Tracking		25		mA

## TECHNICAL SPECIFICATIONS

- Receiver Type : L1 C/A code, 167-channel Venus 8 engine
- Accuracy :
  - Position 2.5m CEP
  - Velocity 0.1m/sec
  - Time 10ns
- Startup Time :
  - 1 second hot start under open sky
  - 29 second cold start under open sky (average)
- Reacquisition : 1s
- Sensitivity : -165dBm tracking
- Multi-path Mitigation : Advanced multi-path detection and suppression
- Update Rate : Supports 1 / 2 / 4 / 5 / 8 / 10 / 20 / 40 Hz update rate (1Hz default)
- Dynamics : 4G (39.2m/sec<sup>2</sup>)
- Operational Limits : Altitude < 18,000m or velocity < 515m/s
- Serial Interface : 3V TTL level
- Protocol : NMEA-0183 V3.01  
GPGGA, GPGLL, GPGSA, GPGSV, GPRMC, GPVTG<sup>1</sup>  
9600 baud, 8, N, 1
- Datum : Default WGS-84  
User definable
- Input Voltage : 3.0V ~ 3.6V DC
- Input Current : ~25mA tracking
- Dimension : 19mm L x 18mm W
- Weight: 9g
- Operating Temperature : -40°C ~ +85°C
- Storage Temperature : -55 ~ +100°C
- Humidity : 5% ~ 95%

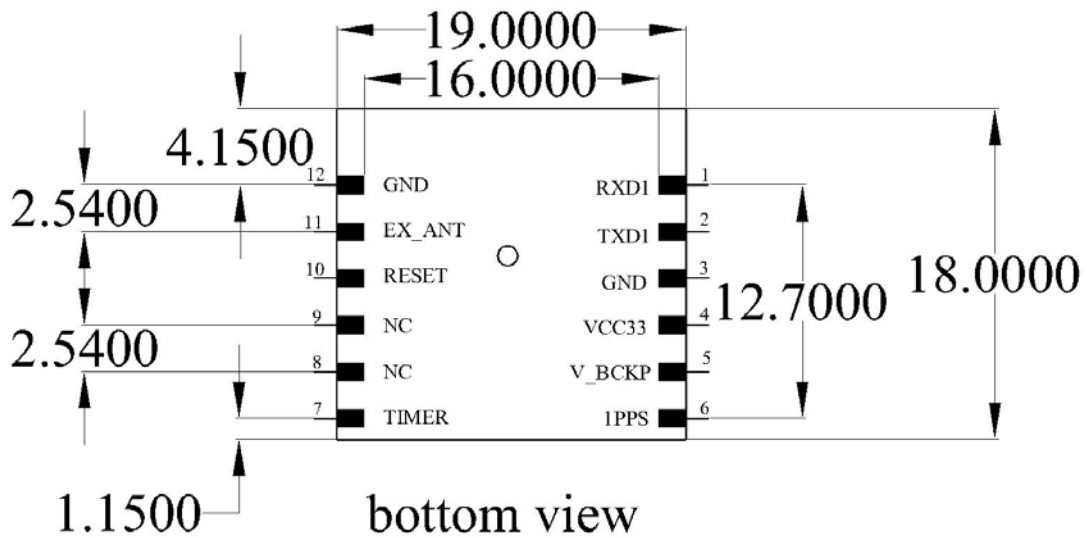
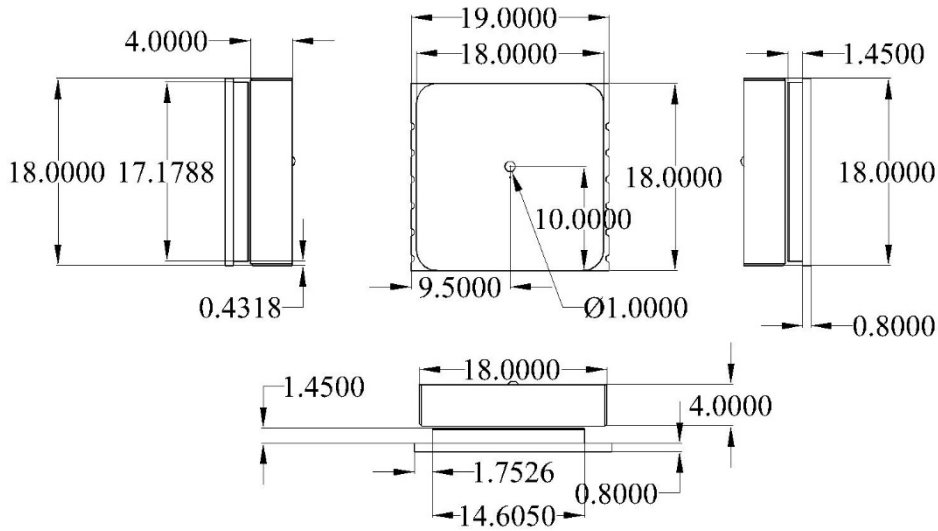
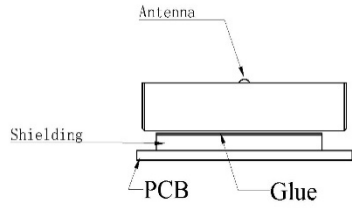

# NMEAMESSAGES

The full descriptions of supported NMEA messages are provided at the following paragraphs.

## GGA - Global Positioning System Fix Data

Time, position and fix related data for a GPS receiver.

Structure:

\$GPGGA,hhmmss.sss,ddmm.mmmm,a,dddmm.mmmm,a,x,xx,x.x,x.x,M,,,,,xxxx\*hh<CR><LF>  
                   1      2      3      4      5 6 7 8 9 10      11

Example:

GPGGA,111636.932,2447.0949,N,12100.5223,E,1,11,0.8,118.2,M,,,,,0000\*02<CR><LF>

Field	Name	Example	Description
1	UTC Time	111636.932	UTC of position in hhmmss.sss format, (000000.000 ~ 235959.999)
2	Latitude	2447.0949	Latitude in ddmm.mmmm format Leading zeros transmitted
3	N/S Indicator	N	Latitude hemisphere indicator, 'N' = North, 'S' = South
4	Longitude	12100.5223	Longitude in dddmm.mmmm format Leading zeros transmitted
5	E/W Indicator	E	Longitude hemisphere indicator, 'E' = East, 'W' = West
6	GPS quality indicator	1	GPS quality indicator 0: position fix unavailable 1: valid position fix, SPS mode 2: valid position fix, differential GPS mode 3: GPS PPS Mode, fix valid 4: Real Time Kinematic. System used in RTK mode with fixed integers 5: Float RTK. Satellite system used in RTK mode. Floating integers 6: Estimated (dead reckoning) Mode 7: Manual Input Mode 8: Simulator Mode
7	Satellites Used	11	Number of satellites in use, (00 ~ 12)
8	HDOP	0.8	Horizontal dilution of precision, (00.0 ~ 99.9)
9	Altitude	108.2	mean sea level (geoid), (-9999.9 ~ 17999.9)
10	DGPS Station ID	0000	Differential reference station ID, 0000 ~ 1023 NULL when DGPS not used
11	Checksum	02	

### GLL – Latitude/Longitude

Latitude and longitude of current position, time, and status.

Structure:

\$GPGLL,ddmm.mmmm,a,dddmm.mmmm,a,hhmmss.sss,A,a\*hh<CR><LF>

1 2 3 4 5 6 7 8

Example:

GPGLL,2447.0944,N,12100.5213,E,112609.932,A,A\*57<CR><LF>

Field	Name	Example	Description
1	Latitude	2447.0944	Latitude in ddmm.mmmm format Leading zeros transmitted
2	N/S Indicator	N	Latitude hemisphere indicator 'N' = North 'S' = South
3	Longitude	12100.5213	Longitude in dddmm.mmmm format Leading zeros transmitted
4	E/W Indicator	E	Longitude hemisphere indicator 'E' = East 'W' = West
5	UTC Time	112609.932	UTC time in hhmmss.sss format (000000.000 ~ 235959.999)
6	Status	A	Status, 'A' = Data valid, 'V' = Data not valid
7	Mode Indicator	A	Mode indicator 'N' = Data not valid 'A' = Autonomous mode 'D' = Differential mode 'E' = Estimated (dead reckoning) mode 'M' = Manual input mode 'S' = Simulator mode
8	Checksum	57	

**GSA – GNSS DOP and Active Satellites**

GPS receiver operating mode, satellites used in the navigation solution reported by the GGA or GNS sentence and DOP values.

Structure:

```
$GPGSA,A,x,xx,xx,xx,xx,xx,xx,xx,xx,xx,xx,xx,xx,x.x,x.x,x.x*hh<CR><LF>
    1 2 3 3 3 3 3 3 3 3 3 3 3 3 4 5 6 7
```

Example:

```
GPGSA,A,3,05,12,21,22,30,09,18,06,14,01,31,,1.2,0.8,0.9*36<CR><LF>
```

Field	Name	Example	Description
1	Mode	A	Mode 'M' = Manual, forced to operate in 2D or 3D mode 'A' = Automatic, allowed to automatically switch 2D/3D
2	Mode	3	Fix type 1 = Fix not available 2 = 2D 3 = 3D
3	Satellite used 1~12	05,12,21,22,30 ,09,18,06,14,0 1,31,,	Satellite ID number, 01 to 32, of satellite used in solution, up to 12 transmitted
4	PDOP	1.2	Position dilution of precision (00.0 to 99.9)
5	HDOP	0.8	Horizontal dilution of precision (00.0 to 99.9)
6	VDOP	0.9	Vertical dilution of precision (00.0 to 99.9)
7	Checksum	36	

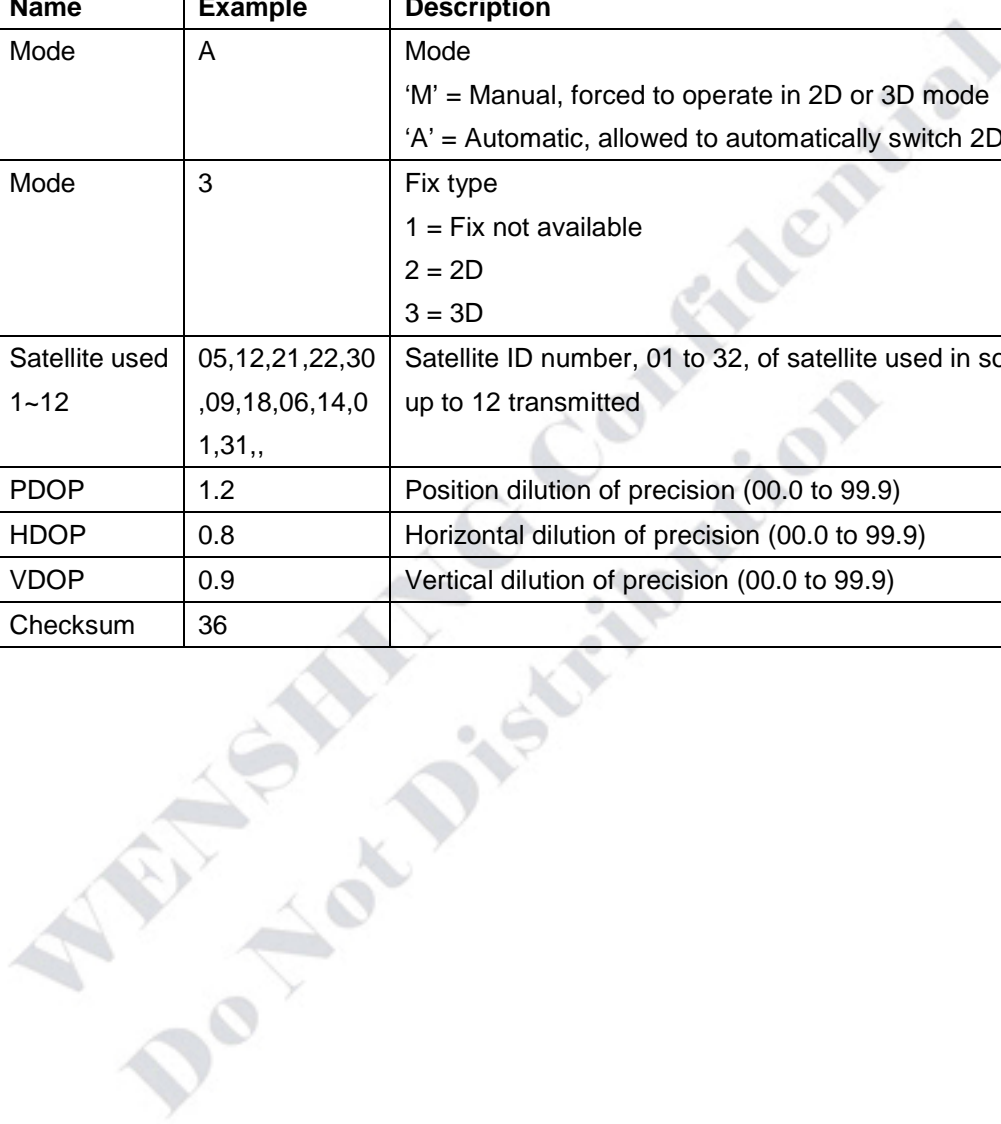



### GSV – GNSS Satellites in View

Number of satellites (SV) in view, satellite ID numbers, elevation, azimuth, and SNR value. Four satellites

maximum per transmission.

Structure:

```
$GPGSV,x,x,xx,xx,xx,xxx,xx,...,xx,xx,xxx,xx *hh<CR><LF>
```

1 2 3 4 5 6 7 4 5 6 7 8

Example:

```
$GPGSV,3,1,12,05,54,069,45,12,44,061,44,21,07,184,46,22,78,289,47*72<CR><LF>
```

```
$GPGSV,3,2,12,30,65,118,45,09,12,047,37,18,62,157,47,06,08,144,45*7C<CR><LF>
```

```
GPGSV,3,3,12,14,39,330,42,01,06,299,38,31,30,256,44,32,36,320,47*7B<CR><LF>
```

Field	Name	Example	Description
1	Number of message	3	Total number of GSV messages to be transmitted (1-3)
2	Sequence number	1	Sequence number of current GSV message
3	Satellites in view	12	Total number of satellites in view (00 ~ 12)
4	Satellite ID	05	Satellite ID number, GPS: 01 ~ 32, SBAS: 33 ~ 64 (33 = PRN120)
5	Elevation	54	Satellite elevation in degrees, (00 ~ 90)
6	Azimuth	069	Satellite azimuth angle in degrees, (000 ~ 359 )
7	SNR	45	C/No in dB (00 ~ 99) Null when not tracking
8	Checksum	72	

### **RMC – Recommended Minimum Specific GNSS Data**

Time, date, position, course and speed data provided by a GNSS navigation receiver.

Structure:

\$GPRMC,hhmmss.sss,A,dddmm.mmmm,a,dddmm.mmmm,a,x.x,x.x,ddmmy,.,a\*hh<CR><LF>

1 2 3 4 5 6 7 8 9 10 11

Example:

GPRMC,111636.932,A,2447.0949,N,12100.5223,E,000.0,000.0,030407,.,A\*61<CR><LF>

Field	Name	Example	Description
1	UTC time	0111636.932	UTC time in hhmmss.sss format (000000.00 ~ 235959.999)
2	Status	A	Status 'V' = Navigation receiver warning 'A' = Data Valid
3	Latitude	2447.0949	Latitude in dddmm.mmmm format Leading zeros transmitted
4	N/S indicator	N	Latitude hemisphere indicator 'N' = North 'S' = South
5	Longitude	12100.5223	Longitude in dddmm.mmmm format Leading zeros transmitted
6	E/W Indicator	E	Longitude hemisphere indicator 'E' = East 'W' = West
7	Speed over ground	000.0	Speed over ground in knots (000.0 ~ 999.9)
8	Course over ground	000.0	Course over ground in degrees (000.0 ~ 359.9)
9	UTC Date	030407	UTC date of position fix, ddmmyy format
10	Mode indicator	A	Mode indicator 'N' = Data not valid 'A' = Autonomous mode 'D' = Differential mode 'E' = Estimated (dead reckoning) mode 'M' = Manual input mode 'S' = Simulator mode
11	checksum	61	

### **VTG – Course Over Ground and Ground Speed**

The Actual course and speed relative to the ground.

Structure:

GPVTG,x.x,T,,M,x.x,N,x.x,K,a\*hh<CR><LF>

1 2 3 4 5

Example:

GPVTG, 000.0,T,,M,000.0,N,0000.0,K,A\*3D<CR><LF>

Field	Name	Example	Description
1	Course	000.0	True course over ground in degrees (000.0 ~ 359.9)
2	Speed	000.0	Speed over ground in knots (000.0 ~ 999.9)
3	Speed	0000.0	Speed over ground in kilometers per hour (0000.0 ~ 1800.0)
4	Mode	A	Mode indicator 'N' = not valid 'A' = Autonomous mode 'D' = Differential mode 'E' = Estimated (dead reckoning) mode 'M' = Manual input mode 'S' = Simulator mode
5	Checksum	3D	