

## 8-Channel, $\pm 70\text{V}$ , 3A Programmable High-Voltage Ultrasound-Transmit Beamformer

### Features

- Eight Channels with Return-to-Zero (RTZ)
- Up to  $\pm 70\text{V}$  Output Voltage
- $\pm 3.0\text{A}$  Output Current
- Stores up to Four Different Patterns
- Independent Programmable Delays
- 80-lead Single 11 x 11 mm VQFN Package

### Applications

- Medical Ultrasound Imaging
- NDT, Non-Destructive Testing
- Arbitrary Pattern Generator
- High-Speed PIN Diode Driver

### General Description

The HV7351 device is an 8-channel programmable high-voltage ultrasound-transmit beamformer. Each channel is capable of swinging up to  $\pm 70\text{V}$  with an active discharge back to 0V. The outputs can source and sink up to 3.0A to achieve fast output rise and fall times. The active discharge is also capable of sourcing and sinking 3.0A for a fast return to ground. The topology of the HV7351 will significantly reduce the number of I/O logic control lines needed.

Each pulser has four associated 64-bit shift registers for storing predetermined transmit patterns and a 10-bit delay counter for controlling the transmit time. One of four arbitrary patterns can be transmitted with adjustable delay, depending on the data loaded into these shift registers and the delay counter. The delay counter can be clocked up to 200 MHz, allowing incremental delays down to 5 ns.

### Typical Application Circuit

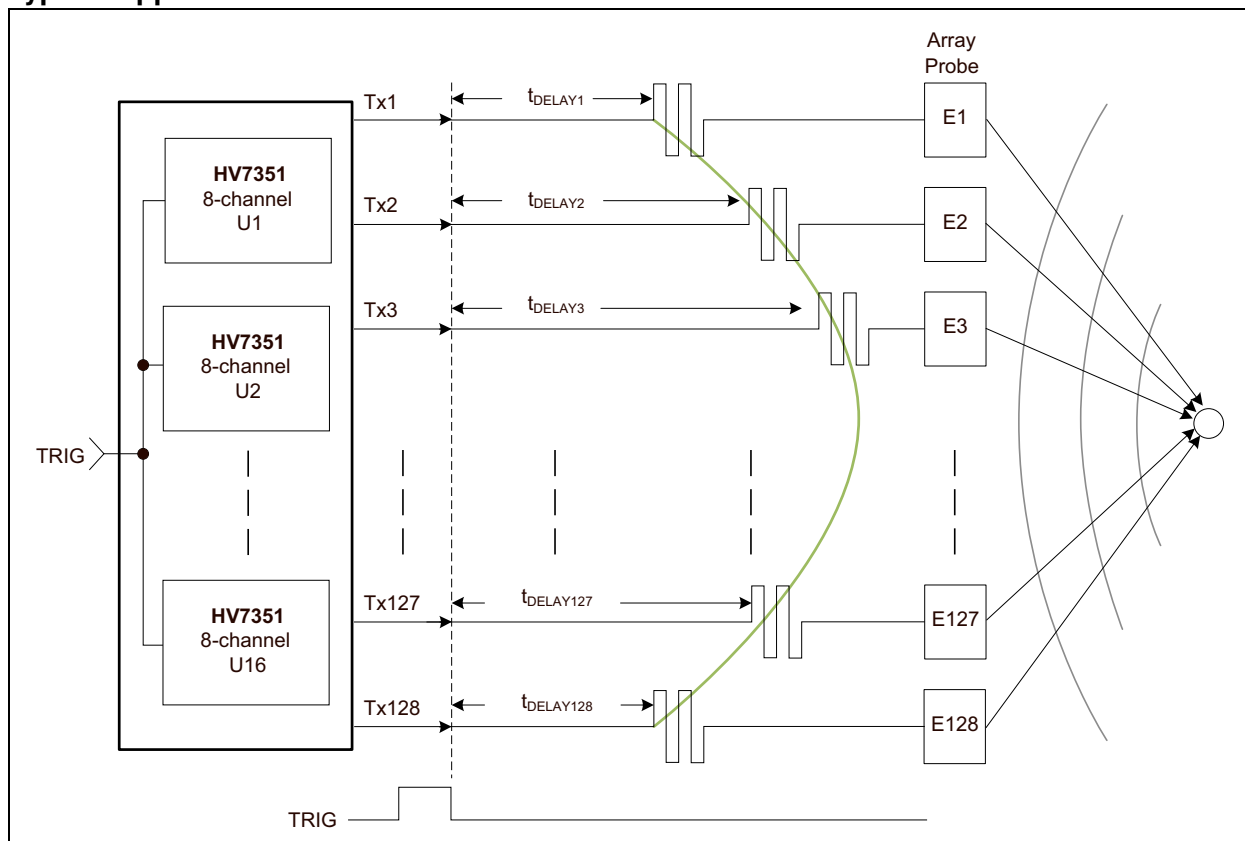

# HV7351

## Package Types (Top View)

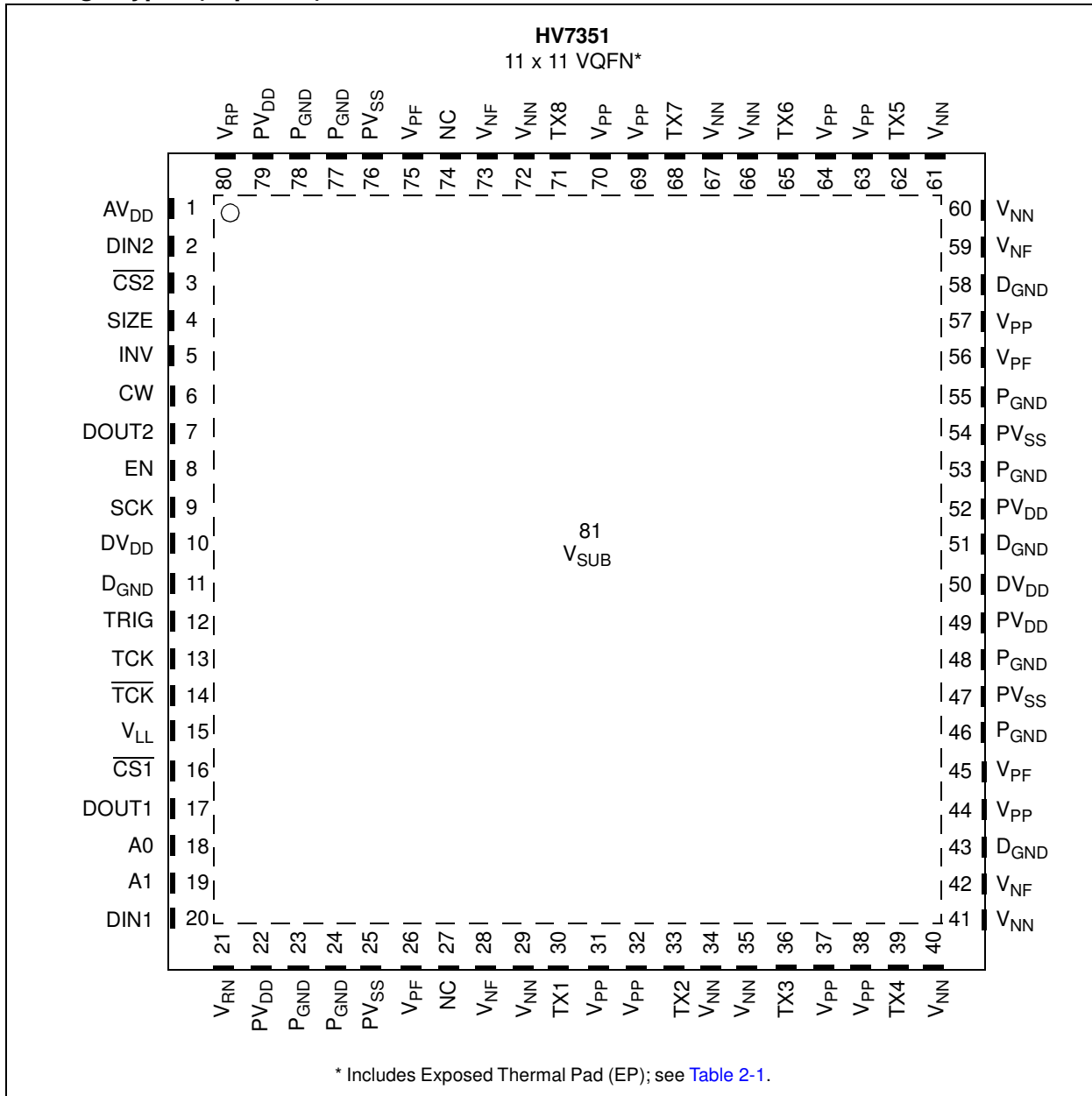

## Block Diagram

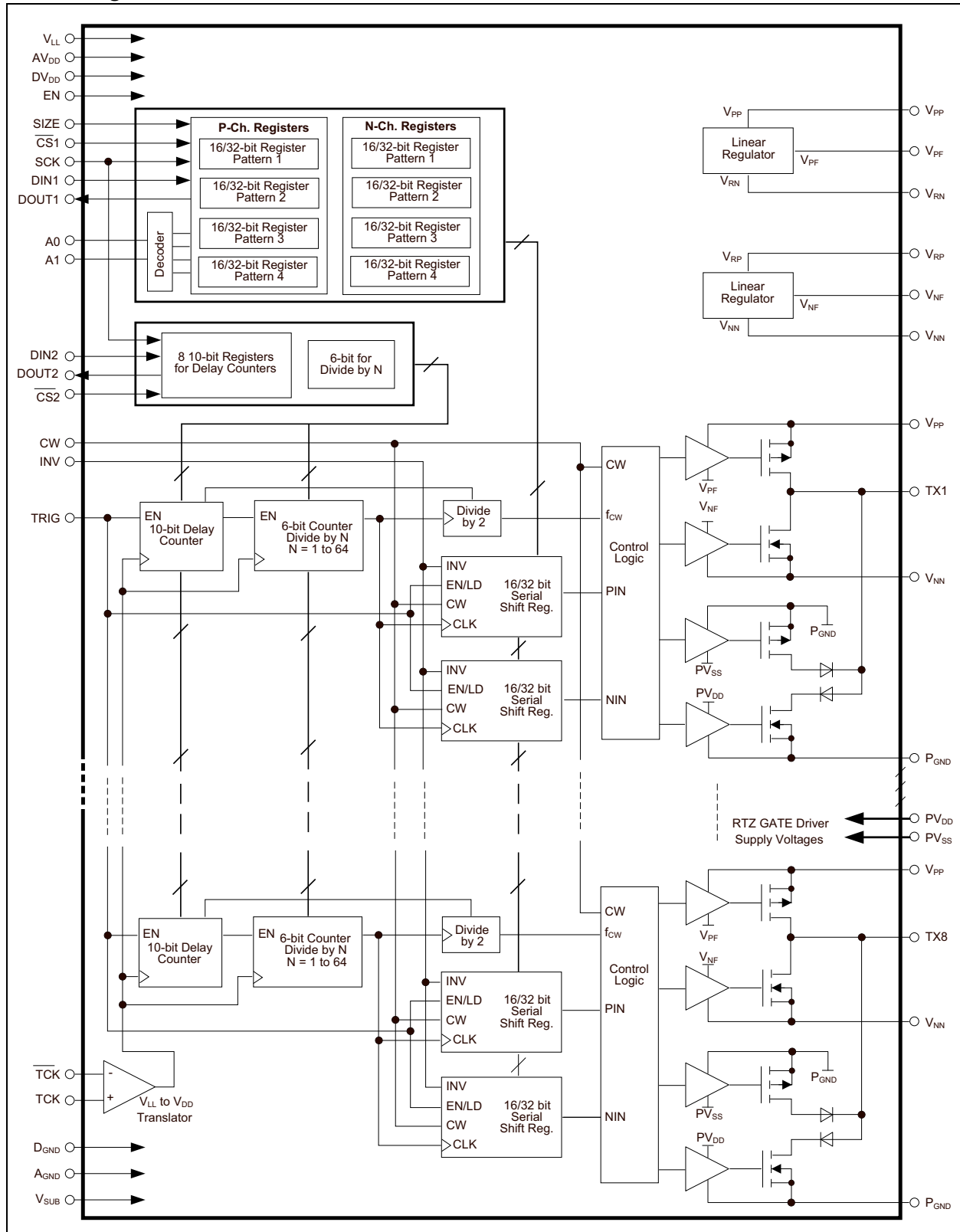

# HV7351

---

NOTES:

## 1.0 ELECTRICAL CHARACTERISTICS

### Absolute Maximum Ratings †

Positive logic supply ( $V_{LL}$ ).....	-0.5V to 5.5V
Positive logic supply voltage ( $DV_{DD}$ ).....	-0.5V to 5.5V
Positive gate drive supply voltage ( $PV_{DD}$ ).....	-0.5V to 5.5V
Positive analog supply voltage ( $AV_{DD}$ ).....	-0.5V to 5.5V
Negative gate drive supply voltage ( $PV_{SS}$ ).....	+0.5V to -5.5V
High-voltage positive supply voltage ( $V_{PP}$ ).....	-0.5V to +80V
High-voltage negative supply voltage ( $V_{NN}$ ).....	+0.5V to -80V
Differential high voltage supply ( $V_{PP} - V_{NN}$ ).....	+160V
Positive floating supply voltage ( $V_{PF}$ ).....	$V_{PP} - 6.0V$ to $V_{PP}$
Negative floating supply voltage ( $V_{NF}$ ).....	$V_{NN}$ to $V_{NN} + 6.0V$
Positive supply for $V_{NF}$ regulator ( $V_{RP}$ ).....	0V to 15V
Negative supply for $V_{PF}$ regulator ( $V_{RN}$ ).....	0V to -15V
Operating temperature.....	-40°C to +125°C
Storage temperature.....	-65°C to +150°C
ESD Rating All Pins.....	0.75 kV

† **Notice:** Stresses above those listed under “Maximum Ratings” may cause permanent damage to the device. This is a stress rating only and functional operation of the device at those or any other conditions above those indicated in the operational sections of this specification is not intended. Exposure to maximum rating conditions for extended periods may affect device reliability.

**TABLE 1-1: OPERATING SUPPLY VOLTAGES**

**Electrical Specifications:** Unless otherwise specified:  $T_A = +25^\circ\text{C}$ . **Boldface** specifications apply over the  $T_A$  range of -20 to +85°C.

Parameter	Sym.	Min.	Typ.	Max.	Units	Conditions
Positive High Voltage Supply	$V_{PP}$	<b>3.0</b>	—	<b>70</b>	V	<b>Note 1</b>
Negative High Voltage Supply	$V_{NN}$	<b>-70</b>	—	<b>-3.0</b>	V	
Logic Interface Voltage	$V_{LL}$	<b>2.85</b>	3.30	<b>3.6</b>	V	
Low-Voltage Positive Analog Supply Voltage	$AV_{DD}$	<b>4.75</b>	5.00	<b>5.25</b>	V	
Low-Voltage Positive Digital Supply Voltage	$DV_{DD}$	<b>4.75</b>	5.00	<b>5.25</b>	V	
Low-Voltage Positive Gate Drive Supply Voltage	$PV_{DD}$	<b>4.75</b>	5.00	<b>5.25</b>	V	
Low-Voltage Negative Gate Drive Supply Voltage	$PV_{SS}$	<b>-5.25</b>	-5.00	<b>-4.75</b>	V	
Low-Voltage Positive Supply for $V_{NF}$ Regulator	$V_{RP}$	<b>4.75</b>	—	<b>12</b>	V	
Low-Voltage Negative Supply for $V_{PF}$ Regulator	$V_{RN}$	<b>-12</b>	—	<b>-4.75</b>	V	
Reference Voltage Logic Trip Point for $\overline{TCK}$ Pin	$\overline{TCK}$	<b>0.4</b> $V_{LL}$	0.5 $V_{LL}$	<b>0.6</b> $V_{LL}$	V	
$\overline{TCK}/\overline{TCK}$ Input Current	$I_{TCK}/I_{\overline{TCK}}$	—	—	±10	µA	$I_{\overline{TCK}} = 0$ to $V_{LL}$ , $T_A = +25^\circ\text{C}$ <b>(Note 1)</b>

**Note 1:** Specification is obtained by characterization and is not 100% tested.

# HV7351

**TABLE 1-2: REGULATOR OUTPUTS**

Parameter	Sym.	Min.	Typ.	Max.	Units	Conditions
Positive Floating Gate Drive Voltage	$V_{PF}$	$V_{PP} - 5.25$	$V_{PP} - 5.00$	$V_{PP} - 4.00$	V	4x1 $\mu$ F ceramic capacitors across $V_{PF}$ and $V_{PP}$
Negative Floating Gate Drive Voltage	$V_{NF}$	$V_{NN} + 4.00$	$V_{NN} + 5.00$	$V_{NN} + 5.25$	V	4x1 $\mu$ F ceramic capacitors across $V_{NF}$ and $V_{NN}$

## ELECTRICAL CHARACTERISTICS

**Electrical Specifications:** unless otherwise specified,  $V_{LL} = 3.3V$ ,  $AV_{DD} = DV_{DD} = PV_{DD} = V_{RP} = 5.0V$ ,  $PV_{SS} = V_{RN} = -5.0V$ ,  $V_{PP} = +70V$ ,  $V_{NN} = -70V$ ,  $T_A = +25^\circ C$ .

Parameter	Sym.	Min.	Typ.	Max.	Units	Conditions
$V_{LL}$ Quiescent Current	$I_{VLLQ}$	—	384	500	$\mu$ A	EN = Low, all inputs are static
$AV_{DD}$ Quiescent Current	$I_{AVDDQ}$	—	12	30	$\mu$ A	EN = Low, all inputs are static
$DV_{DD}$ Quiescent Current	$I_{DVDDQ}$	—	12	30		
$PV_{DD}$ Quiescent Current	$I_{PVDDQ}$	—	70	100		
$V_{RP}$ Quiescent Current	$I_{VRPQ}$	—	0.3	6	$\mu$ A	EN = Low, all inputs are static
$V_{RN}$ Quiescent Current	$I_{VRNQ}$	—	-0.01	6		
$PV_{SS}$ Quiescent Current	$I_{PVSSQ}$	-85	-45	—	$\mu$ A	EN = Low, all inputs are static
$V_{PP}$ Quiescent Current	$I_{VPPQ}$	—	2.6	6	$\mu$ A	EN = Low, all inputs are static
$V_{NN}$ Quiescent Current	$I_{VNNQ}$	—	-1.6	6		
$V_{LL}$ Enabled Quiescent Current	$I_{VLLEN}$	—	390	500	$\mu$ A	EN = High, all inputs are static
$AV_{DD}$ Enabled Quiescent Current	$I_{AVDDEN}$	—	600	800	$\mu$ A	EN = High, all inputs are static
$DV_{DD}$ Enabled Quiescent Current	$I_{DVDDEN}$	—	22	55		
$PV_{DD}$ Enabled Quiescent Current	$I_{PVDDEN}$	—	44	100	$\mu$ A	EN = High, all inputs are static
$V_{RP}$ Enabled Quiescent Current	$I_{VRPEN}$	—	450	650	$\mu$ A	EN = High, all inputs are static
$V_{RN}$ Enabled Quiescent Current	$I_{VRNEN}$	-650	-350	—		
$PV_{SS}$ Enabled Quiescent Current	$I_{PVSSEN}$	-100	-44	—	$\mu$ A	EN = High, all inputs are static
$V_{PP}$ Enabled Quiescent Current	$I_{VPPEN}$	—	370	620	$\mu$ A	EN = High, all inputs are static
$V_{NN}$ Enabled Quiescent Current	$I_{VNNEN}$	-620	-420	—		
$V_{LL}$ current at 80 MHz Clock	$I_{VLLCW}$	—	500	—	$\mu$ A	$V_{PP} = +5.0V$ , $V_{NN} = -5.0V$ , EN = High, CW = High, 80 MHz on $\overline{TCK}$ , $0.5V_{LL}$ on $\overline{TCK}$ , all 8 channels active at 5.0 MHz, no load (Note 1)
$DV_{DD}$ current at CW = 5 MHz	$I_{DVDDCW}$	—	25	—	mA	
$V_{PP}$ current at CW = 5 MHz	$I_{VPPCW}$	—	141	—	mA	
$V_{NN}$ current at CW = 5 MHz	$I_{VNNCW}$	—	98	—	mA	

**Note 1:** Specification is obtained by characterization and is not 100% tested.

## AC ELECTRICAL CHARACTERISTICS

<b>Electrical Specifications:</b> unless otherwise specified, $V_{LL} = 3.3V$ , $AV_{DD} = DV_{DD} = PV_{DD} = V_{RP} = 5.0V$ , $PV_{SS} = V_{RN} = -5.0V$ , $V_{PP} = +70V$ , $V_{NN} = -70V$ , $T_A = +25^\circ C$ .						
Parameter	Sym.	Min.	Typ.	Max.	Units	Conditions
Transmit Clock Frequency	$f_{TCK}$	0	—	200	MHz	
Serial Clock Frequency	$f_{SCK}$	0	—	80	MHz	No daisy chain
		0	—	70		Daisy chained ( <b>Note 2</b> )
Set-up Time Data into SCK	$t_{SU-DIN}$	2	—	—	ns	<b>Note 1</b>
Hold Time SCK to Data In	$t_{H-DIN}$	2	—	—	ns	<b>Note 1</b>
Set-up Time $\overline{CS1}$ Low to SCK	$t_{SU-CS1}$	2	—	—	ns	<b>Note 2</b>
Set-up Time $\overline{CS2}$ Low to SCK	$t_{SU-CS2}$	2	—	—	ns	<b>Note 2</b>
Set-up Time from TRIG Fall to TCK Rise Edge	$t_{SU-TRIG}$	2	—	—	ns	<b>Note 2</b>
TRIG Pulse Width	$t_{W-TRIG}$	2 x TCK	—	—	Cycle	<b>Note 2</b>
SCK to Data Out Low to High Delay Time	$t_{LHDO}$	3	9	12	ns	For DOUT1 ( <b>Note 1</b> )
		3	9	10		For DOUT2 ( <b>Note 1</b> )
SCK to Data Out High to Low Delay Time	$t_{HLDO}$	3	9	12	ns	For DOUT1 ( <b>Note 1</b> )
		3	9	10		For DOUT2 ( <b>Note 1</b> )
A1A0 Pulse Width	$t_{WA1A0}$	$t_{W-TRIG} + 40$	—	—	ns	<b>Note 2</b>
Set-up Time A1A0 to TRIG Rising Edge	$t_{SUA1A0}$	—	20	—	ns	<b>Note 1</b>
Hold Time A1A0 to TRIG Falling Edge	$t_{HA1A0}$	—	20	—	ns	
Device Enable Time	$t_{EN-ON}$	—	1	—	ms	1.0 $\mu F$ capacitor on every $V_{PF}$ and $V_{NF}$ pin ( <b>Note 1</b> )
Device Disable Time	$t_{EN-OFF}$	—	—	100	ns	<b>Note 1</b>
Output Rise Time from 0V to +HV	$t_{r1}$	—	9	13	ns	Load = 330 pF  2.5 k $\Omega$
Output Fall Time from 0V to -HV	$t_{f1}$	—	9	13	ns	
Damping Output Rise Time from -HV to 0V	$t_{r2}$	—	9	13	ns	
Damping Output Fall Time from +HV to 0V	$t_{f2}$	—	9	13	ns	
Output Rise Time from -HV to +HV	$t_{r3}$	—	17	23	ns	
Output Fall Time from +HV to -HV	$t_{f3}$	—	17	23	ns	
CW Output Rise Time	$t_{rcw}$	—	9	16	ns	
CW Output Fall Time	$t_{fcw}$	—	9	16	ns	$V_{PP} = +5.0V$ , $V_{NN} = -5.0V$ Load = 330 pF  2.5 k $\Omega$

**Note 1:** Specification is obtained by characterization and is not 100% tested.

**Note 2:** Specification is for design guidance only.

# HV7351

## AC ELECTRICAL CHARACTERISTICS (CONTINUED)

<b>Electrical Specifications:</b> unless otherwise specified, $V_{LL} = 3.3V$ , $AV_{DD} = DV_{DD} = PV_{DD} = V_{RP} = 5.0V$ , $PV_{SS} = V_{RN} = -5.0V$ , $V_{PP} = +70V$ , $V_{NN} = -70V$ , $T_A = +25^\circ C$ .						
Parameter	Sym.	Min.	Typ.	Max.	Units	Conditions
Output Propagation Delay Rise Time 1	$t_{dr1}$	11	14	18	ns	No Load
Output Propagation Delay Fall Time 1	$t_{df1}$	11	14	18	ns	
Output Propagation Delay Rise Time 2	$t_{dr2}$	12	15	19	ns	
Output Propagation Delay Fall Time 2	$t_{df2}$	11	15	18	ns	
Output Propagation Delay Rise Time 3	$t_{dr3}$	12	15	19	ns	
Output Propagation Delay Fall Time 3	$t_{df3}$	11	15	18	ns	
CW Output Propagation Delay Time from Low to High	$t_{dcwlh}$	10	13	17	ns	$V_{PP} = +5.0V$ , $V_{NN} = -5.0V$ No Load
CW Output Propagation Delay Time from High to Low	$t_{dcwhl}$	10	14	17	ns	
Delay Time Matching	$\Delta t_{dcwhl}$	—	$\pm 0.7$	—	ns	P to N, channel-to-channel matching
Delay Jitter On Rise or Fall	$t_{JCW}$	—	13	—	ps	$V_{PP} = +5.0V$ , $V_{NN} = -5.0V$ , Load = 50 $\Omega$ ( <b>Note 2</b> )
Latency	LAT		3.5		TCK	<b>Note 2</b>
<b>Output P-Channel MOSFET to <math>V_{PP}</math>, CW = 0</b>						
Output Saturation Current	$I_{OUT}$	2.2	3.2	—	A	
Output ON-Resistance	$R_{ON}$	—	4.2	—	$\Omega$	$I_{OUT} = 100\text{ mA}$
Output Capacitance	$C_{OSS}$	—	62	—	pF	$V_{PP} - V_{OUT} = 25V$ , $f = 1.0\text{ MHz}$ ( <b>Note 2</b> )
<b>Output N-Channel MOSFET to <math>V_{NN}</math>, CW = 0</b>						
Output Saturation Current	$I_{OUT}$	2.2	3.2	—	A	
Output ON-Resistance	$R_{ON}$	—	2.4	—	$\Omega$	$I_{OUT} = -100\text{ mA}$
Output Capacitance	$C_{OSS}$	—	50	—	pF	$V_{NN} - V_{OUT} = -25V$ , $f = 1.0\text{ MHz}$ ( <b>Note 2</b> )
<b>Output P-Channel MOSFET to <math>V_{PP}</math>, CW = 1</b>						
Output Saturation Current	$I_{OUT}$	1.2	1.5	—	A	
Output ON-Resistance	$R_{ON}$	—	8	—	$\Omega$	$I_{OUT} = 100\text{ mA}$
Output Capacitance	$C_{OSS}$	—	62	—	pF	$V_{PP} - V_{OUT} = 25V$ , $f = 1.0\text{ MHz}$ ( <b>Note 2</b> )

**Note 1:** Specification is obtained by characterization and is not 100% tested.

**2:** Specification is for design guidance only.



## AC ELECTRICAL CHARACTERISTICS (CONTINUED)

**Electrical Specifications:** unless otherwise specified,  $V_{LL} = 3.3V$ ,  $AV_{DD} = DV_{DD} = PV_{DD} = V_{RP} = 5.0V$ ,  $PV_{SS} = V_{RN} = -5.0V$ ,  $V_{PP} = +70V$ ,  $V_{NN} = -70V$ ,  $T_A = +25^\circ C$ .

Parameter	Sym.	Min.	Typ.	Max.	Units	Conditions
<b>Output N-Channel MOSFET to <math>V_{NN}</math>, <math>CW = 1</math></b>						
Output Saturation Current	$I_{OUT}$	1.2	1.5	—	A	
Output ON-Resistance	$R_{ON}$	—	6.6	—	$\Omega$	$I_{OUT} = -100\text{ mA}$
Output Capacitance	$C_{OSS}$	—	50	—	pF	$V_{NN} - V_{OUT} = -25V$ , $f = 1.0\text{ MHz}$ (Note 2)
<b>Damping P-Channel MOSFET to <math>P_{GND}</math></b>						
Output Saturation Current	$I_{OUT}$	2.2	3.2	—	A	
Output ON-Resistance	$R_{ON}$	—	4	—	$\Omega$	$I_{OUT} = 100\text{ mA}$
Output capacitance	$C_{OSS}$	—	62	—	pF	$V_{PP} - V_{OUT} = 25V$ , $f = 1.0\text{ MHz}$ (Note 2)
<b>Damping N-Channel MOSFET to <math>P_{GND}</math></b>						
Output Saturation Current	$I_{OUT}$	2.2	3.2	—	A	
Output ON-Resistance	$R_{ON}$	—	2.3	—	$\Omega$	$I_{OUT} = -100\text{ mA}$
Output Capacitance	$C_{OSS}$	—	50	—	pF	$V_{NN} - V_{OUT} = -25V$ , $f = 1.0\text{ MHz}$ (Note 2)
<b>Logic Inputs</b>						
Clock Input Current	$I_{TCK}$	—	$\pm 1.0$	—	$\mu A$	Voltage 0 to $V_{LL}$
Clock Input High Voltage	$V_{IH\_TCK}$	$V_{TCK} + 0.15$	—	$V_{LL}$	V	$TCK = 0.5V_{LL}$ (Note 2)
Clock Input Low Voltage	$V_{IL\_TCK}$	0	—	$V_{TCK} - 0.15$	V	
Logic Input High Voltage	$V_{IH}$	$0.8V_{LL}$	—	$V_{LL}$	V	For all logic inputs except clock inputs
Logic Input Low Voltage	$V_{IL}$	0	—	$0.2V_{LL}$	V	
Input Logic High Current	$I_{IH}$	—	—	1	$\mu A$	
Input Logic Low Current	$I_{IL}$	-1	—	—	$\mu A$	
Output Logic Low Voltage	$V_{OL}$	0	—	0.7	V	$I_{OUT} = 0\text{ to }-10\text{ mA}$
Output Logic High Voltage	$V_{OH}$	$V_{LL} - 0.7$	—	$V_{LL}$	V	$I_{OUT} = 0\text{ to }10\text{ mA}$
Input Logic Capacitance	$C_{IN}$	—	—	5.0	pF	Note 2

**Note 1:** Specification is obtained by characterization and is not 100% tested.

**2:** Specification is for design guidance only.

# HV7351

## TEMPERATURE SPECIFICATIONS

<b>Electrical Specifications:</b> unless otherwise specified, $V_{LL} = 3.3V$ , $AV_{DD} = DV_{DD} = PV_{DD} = V_{RP} = 5.0V$ , $PV_{SS} = V_{RN} = -5.0V$ , $V_{PP} = +70V$ , $V_{NN} = -70V$ , $T_A = +25^{\circ}C$ .						
Parameters	Sym.	Min.	Typ.	Max.	Units	Conditions
<b>Temperature Ranges</b>						
Operating Ambient Temperature Range	$T_A$	-40	—	+125	$^{\circ}C$	
Storage Temperature Range	$T_A$	-65	—	+150	$^{\circ}C$	
Maximum Junction Temperature	$T_J$	-40	—	+150	$^{\circ}C$	
<b>Package Thermal Resistances</b>						
Thermal Resistance, 80L-11x11 VQFN	$\theta_{JA}$	—	14	—	$^{\circ}C/W$	

**TABLE 1-3: LOGIC TRUTH TABLE**

Mode	Inputs						Outputs			Comments
	EN	CW	10-bit Counter	INV	NIN	PIN	N-Ch.	P-Ch.	RTZ	
Non-CW mode. Outputs not inverted. Outputs are controlled by data in the shift registers	1	0	X	X	0	0	OFF	OFF	ON	Return-to-Zero (RTZ) is activated when NIN and PIN are both low. Output is pulled to ground through a series diode.
	1	0	X	0	0	1	OFF	ON	OFF	Not inverted. Logic 1 in the P-Channel register turns on the output P-Channel MOSFET.
	1	0	X	0	1	0	ON	OFF	OFF	Not inverted. Logic 1 in the N-Channel register turns on the output N-Channel MOSFET.
	1	0	X	X	1	1	OFF	OFF	OFF	Avoids cross overcurrent. A logic 1 in both P- and N-Channel registers will put the output in a High Z state.
Non-CW mode. Outputs are inverted. Outputs are controlled by data in the shift registers	1	0	X	1	0	1	ON	OFF	OFF	Transmit pattern is inverted
	1	0	X	1	1	0	OFF	ON	OFF	
CW mode. Output follows $f_{CW}$	1	X	All 1	X	X	X	OFF	OFF	OFF	If 10-bit counter reach all 1, then the channel will be turned OFF.
	1	1	Not all 1	X	X	X	OFF/ON	ON/OFF	OFF	The channel's output follows the $f_{CW}$ signal. The shift registers for PIN and NIN remain static to save power.
Device Disabled	0	X	X	X	X	X	OFF	OFF	OFF	High Z state

**Legend:** X = Don't care.

## 1.1 Timing Diagrams

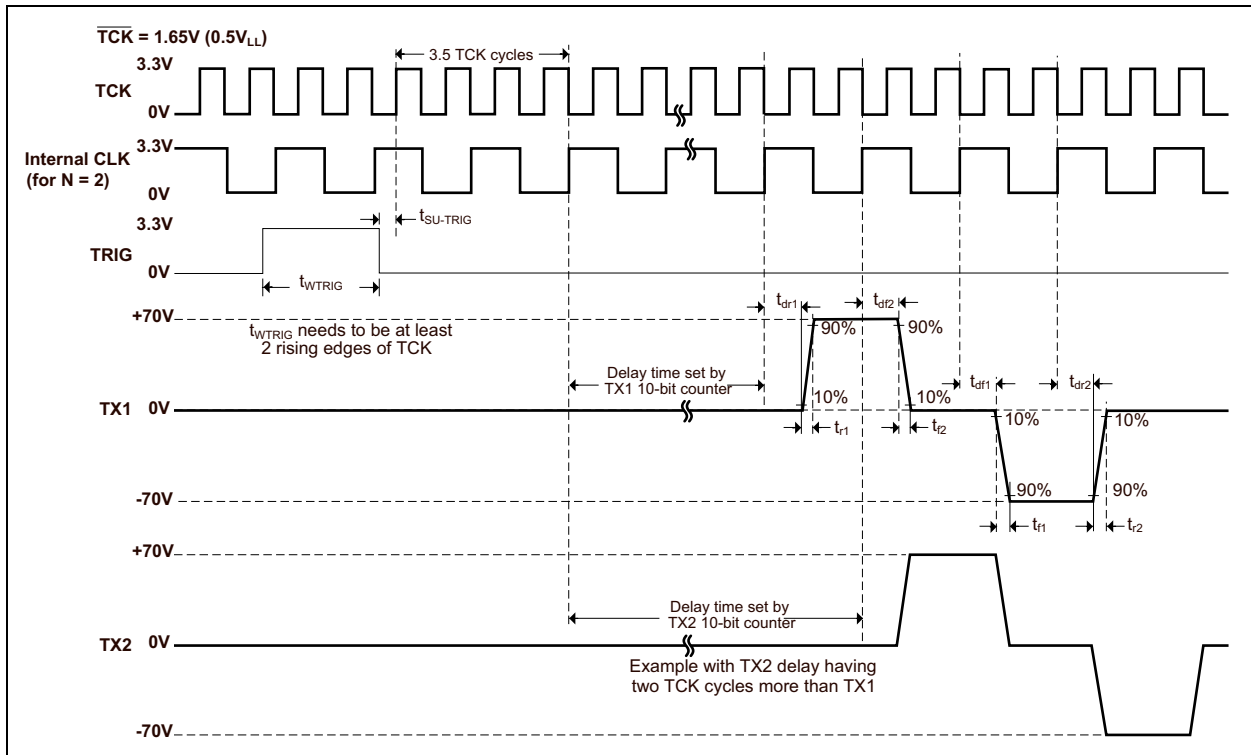

**FIGURE 1-1:** Timing Diagram of 3-Level, 1-Cycle Bipolar RTZ TX Pulse.

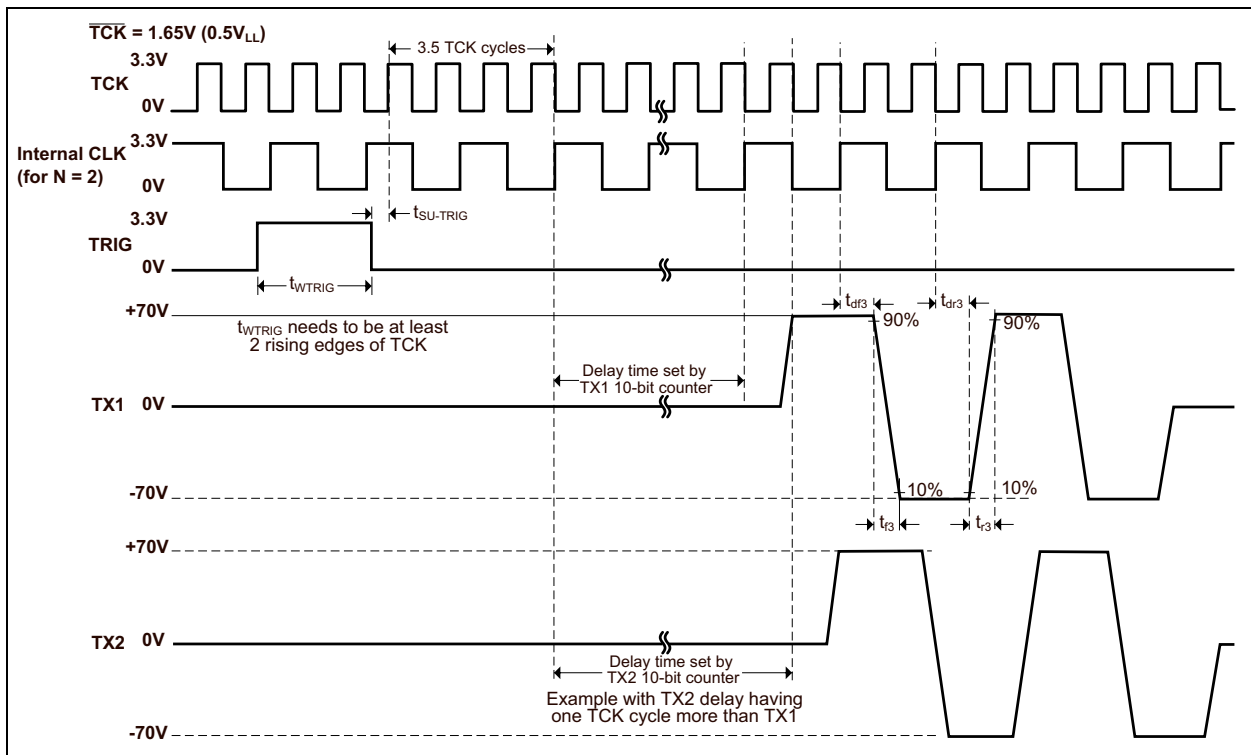

**FIGURE 1-2:** Timing Diagram of 2-Level 2-Cycle Bipolar, non-RTZ TX Pulses with Damping.

# HV7351

---

NOTES:

## 2.0 PIN DESCRIPTION

The descriptions of the pins are listed in [Table 2-1](#).

**TABLE 2-1: PIN FUNCTION TABLE**

Pin	Symbol	Description
1	AV <sub>DD</sub>	Positive analog supply voltage (+5.0V)
2	DIN2	Serial data in for delay counters and frequency divider
3	$\overline{\text{CS2}}$	Activates DIN2. Input logic high = off, input logic low = on.
4	SIZE	Sets pattern width to either 16-bits or 32-bits. Logic low = 16-bits, logic high = 32-bits.
5	INV	Inverts the TX output waveform. See <a href="#">Table 1-3</a> for details.
6	CW	Activates CW mode. Logic low = non-CW mode, logic high = CW mode. See <a href="#">Table 1-3</a> for details.
7	DOUT2	Data out for delay counters and frequency divider
8	EN	Enables and disables device. Logic low = off, logic high = on.
9	SCK	Serial clock input for serial shift registers
10, 50	DV <sub>DD</sub>	Positive digital supply voltage (+5.0V)
11, 43, 51, 58	D <sub>GND</sub>	Digital ground
12	TRIG	Toggles all TX outputs to transmit. Needs to be high for two rising edges of TCK. Delay counters will start on the rising edge of the TCK pin right after the falling edge of the TRIG signal. See <a href="#">Section 1.1 "Timing Diagrams"</a> for details.
13	TCK	The TCK and $\overline{\text{TCK}}$ pins can be driven by LVDS or SSTL types of output in a differential manner. The TCK pin can be driven by LVCMOS single-ended output, while setting the $\overline{\text{TCK}}$ to GND (or DC value of 0.4V to 0.6V). The logic trip point is on the TCK rising edge and on the $\overline{\text{TCK}}$ falling edge, crossing in the differential manner. In the single-ended case, the trip point is on the TCK rising edge.
14	$\overline{\text{TCK}}$	
15	V <sub>LL</sub>	Logic interface supply voltage (3.3V)
16	$\overline{\text{CS1}}$	Activates DIN1. Input logic high = off, input logic low = on
17	DOUT1	Data out for P-Channel and N-Channel pattern registers
18	A0	Decoded to select 1 of 4 patterns to be loaded
19	A1	
20	DIN1	Serial data in for P-Channel and N-Channel pattern registers
21	V <sub>RN</sub>	Negative supply for V <sub>PF</sub> regulator (-5.0V)
22, 49, 52, 79	PV <sub>DD</sub>	Positive gate drive supply voltage for RTZ output transistors (+5.0V)
23, 24, 46, 48, 53, 55, 77, 78	P <sub>GND</sub>	Power ground path for RTZ output transistors
25, 47, 54, 76	PV <sub>SS</sub>	Negative gate drive supply voltage for RTZ output transistors (-5.0V)
26, 45, 56, 75	V <sub>PF</sub>	Linear regulator output gate drive voltage for the P-Channel output transistors. A low voltage 1.0 $\mu\text{F}$ ceramic capacitor needs to be connected across every V <sub>PF</sub> and V <sub>PP</sub> pins. There are four capacitors required in total.
27	NC	No connection
28, 42, 59, 73	V <sub>NF</sub>	Linear regulator output gate drive voltage for the N-Channel output transistors. A low voltage 1.0 $\mu\text{F}$ ceramic capacitor needs to be connected across every V <sub>NF</sub> to V <sub>NN</sub> pins. There are four capacitors required in total.
29, 34, 35, 40, 41, 60, 61, 66, 67, 72	V <sub>NN</sub>	Negative high voltage supply (-3.0V to -70V)
30	TX1	Transmit pulser outputs for channel 1
31, 32, 37, 38, 44, 57, 63, 64, 69, 70	V <sub>PP</sub>	Positive high voltage supply (+3.0V to +70V)

# HV7351

---

**TABLE 2-1: PIN FUNCTION TABLE (CONTINUED)**

Pin	Symbol	Description
33	TX2	Transmit pulser outputs for channel 2
36	TX3	Transmit pulser outputs for channel 3
39	TX4	Transmit pulser outputs for channel 4
62	TX5	Transmit pulser outputs for channel 5
65	TX6	Transmit pulser outputs for channel 6
68	TX7	Transmit pulser outputs for channel 7
71	TX8	Transmit pulser outputs for channel 8
74	NC	No connection
80	V <sub>RP</sub>	Positive supply for V <sub>NF</sub> regulator (+5.0V)
81	V <sub>SUB</sub>	Exposed center pad must be externally connected to the ground (GND, 0V) on PCB. (D <sub>GND</sub> ).

## 3.0 DEVICE DESCRIPTION

### 3.1 Loading Data into the Four 16/32 bit Pattern Registers

A detailed circuit diagram of the pattern registers is shown in Figure 3-1. There are four programmable patterns that can be stored. One of four patterns can be selected via the two input logic decoder pins, A1 and A0. Data can be loaded on the selected pattern. Each pattern can be either 16- or 32-bits wide. The SIZE pin determines whether they are 16- or 32-bits wide. SIZE = H will set the pattern to be 32-bits wide while SIZE = L will set it to 16-bits wide. DIN1 is the input data for the register. When CS1 is high, data will not be shifted in. Data is shifted in only when CS1 is low.

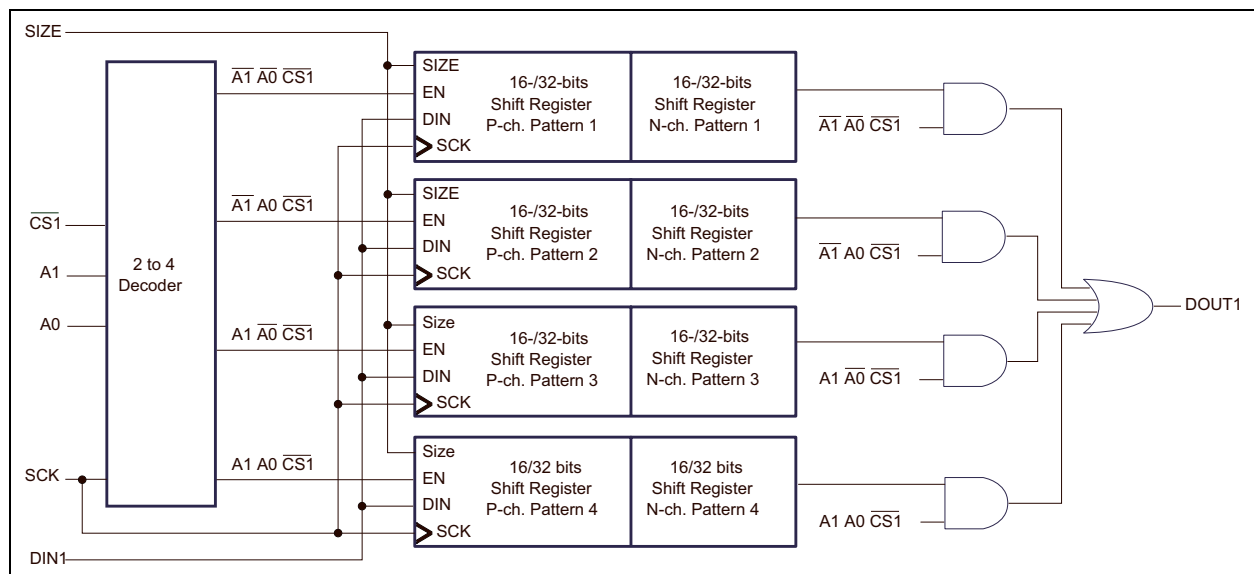

**FIGURE 3-1:** Pattern Register Circuit Diagram.

With SIZE = H, the circuit is effectively a 64-bit serial shift register. The data first enters into the P-Channel register and continues to be shifted through to the N-Channel register. Data is clocked in during the rising edge of the clock. There is no activity during the falling edge of the clock. The DIN1 data enters into the S64 of P-Channel register and exits the S1 of N-Channel register from DOUT1. The SPI writing operation of the waveform pattern registers are LSB first.

Data is shifted in during the rising edge of the clock. S1 is the first bit shifted in, entering the P-Channel register. After 64 clock cycles, S1 will be located in the N-Channel register, as shown in Figure 3-2. It will also be clocked out to DOUT1.

#### EXAMPLE 3-1:

For: SIZE = High, 32-bits wide  
 (SIZE = Low, 16-bits wide)  
 A1 = A0 = Low, Pattern 1 selected  
 CS1 = Low, data can be shifted in

64-bit Serial Shift Register:  
 32 bits for the P-Channel  
 and  
 32 bits for the N-Channel

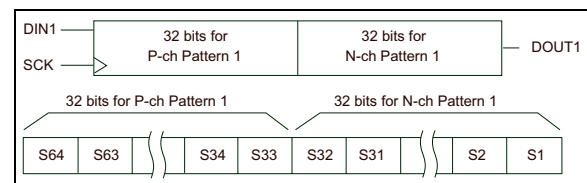

**FIGURE 3-2:** Waveform Pattern Register.

A 2-to-4 decoder is provided to select which of the four patterns is to be used for all of the outputs. Logic inputs A1 and A0 determine which patterns are selected, following Table 3-1. Once A1 and A0 are set, a rising edge on the trigger logic input pin will automatically load the selected pattern to all of the outputs.

**TABLE 3-1: DECODER TRUTH TABLE**

Logic Decoder Input		Pattern Selected
A1	A2	
0	0	1
0	1	2
1	0	3
1	1	4

### 3.2 Loading Data into the Delay Counters and the Divide-by-N Counter

Each output channel (TX) has its own programmable 10-bit delay counter. For 8 channels, 80 bits are needed. A 6-bit divide-by-N counter is also provided to program the desired TX frequency. To program all the individual delay counters and the divide-by-N counter, an 86-bit serial shift register is provided. It uses the same clock input that the pattern registers uses. DIN2 is the input data for this register. When CS2 is high, data will not be shifted in. Data is shifted in only when CS2 is low.

As shown in Figure 3-3, the data first enters into the 10-bit register for the TX8 delay counter and continues to be shifted through to the 6-bit register for the divide-by-N counter. Data is clocked in during the rising edge of the clock. There is no activity during the falling edge of the clock. The MSB bit in the 6-bit divide-by-N register is clocked out into DOUT2 for cascading multiple devices, if desired.

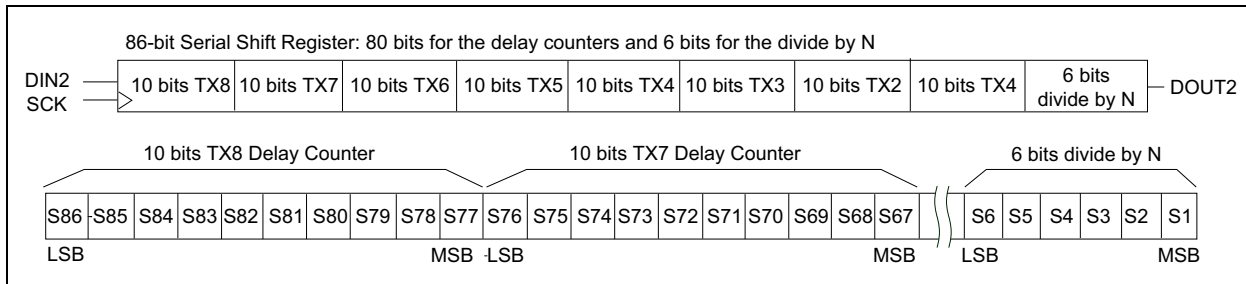

**FIGURE 3-3:** Delay and Divide-by-N Registers.

### 3.3 10-Bit Delay Counter

The TCK and  $\overline{\text{TCK}}$  pins are the input clock for the 10-bit delay counter. The maximum capable clock frequency is up to 200 MHz. The counter counts upward.

**TABLE 3-2: DELAY COUNTER**

MSB									LSB	Delay Time
0	0	0	0	0	0	0	0	0	0	1023 TCK cycles
0	0	0	0	0	0	0	0	0	1	1022 TCK cycles
0	0	0	0	0	0	0	0	1	0	1021 TCK cycles
0	0	0	0	0	0	0	0	1	1	1020 TCK cycles
•	•	•	•	•	•	•	•	•	•	•
•	•	•	•	•	•	•	•	•	•	•
•	•	•	•	•	•	•	•	•	•	•
1	1	1	1	1	1	1	1	0	0	3 TCK cycles
1	1	1	1	1	1	1	1	0	1	2 TCK cycles
1	1	1	1	1	1	1	1	1	0	1 TCK cycle
1	1	1	1	1	1	1	1	1	1	No trigger



## 3.4 6-Bit Divide-by-N Counter

The TCK and  $\overline{\text{TCK}}$  pins are the input clock for the 6-bit divide-by-N counter. It generates the clock frequency for the 16-/32-bit serial shift register for the output P- and N-Channel patterns. Each clock cycle will set the TX output to be either at  $V_{PP}$ ,  $V_{NN}$ , ground or high-impedance, depending on what was preprogrammed in their corresponding registers.

**TABLE 3-3: 6-BIT DIVIDE-BY-N COUNTER REGISTER**

MSB						LSB	Output Shift Register Clock Frequency
0	0	0	0	0	0	0	$f_{\text{TCK}} \div 64$
0	0	0	0	0	1	1	$f_{\text{TCK}} \div 63$
0	0	0	0	1	0	0	$f_{\text{TCK}} \div 62$
0	0	0	0	1	1	1	$f_{\text{TCK}} \div 61$
•	•	•	•	•	•	•	•
•	•	•	•	•	•	•	•
•	•	•	•	•	•	•	•
1	1	1	1	0	0	0	$f_{\text{TCK}} \div 4$
1	1	1	1	0	1	1	$f_{\text{TCK}} \div 3$
1	1	1	1	1	0	0	$f_{\text{TCK}} \div 2$
1	1	1	1	1	1	1	$f_{\text{TCK}} \div 1$

# HV7351

---

NOTES:

## 4.0 PACKAGING INFORMATION

### 4.1 Package Marking Information

80-Lead VQFN (11x11x1.0 mm)

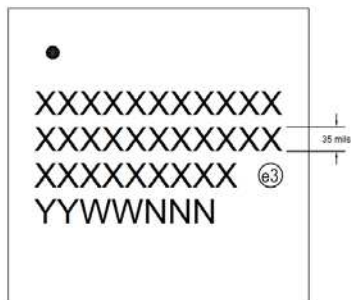

Example

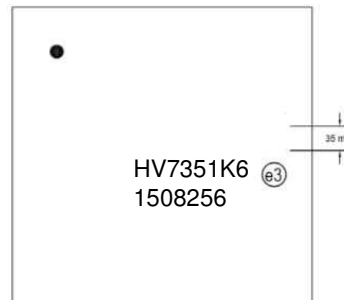

<b>Legend:</b>	XX...X	Product Code or Customer-specific information
	Y	Year code (last digit of calendar year)
	YY	Year code (last 2 digits of calendar year)
	WW	Week code (week of January 1 is week '01')
	NNN	Alphanumeric traceability code
	(e3)	Pb-free JEDEC designator for Matte Tin (Sn)
	*	This package is Pb-free. The Pb-free JEDEC designator (e3) can be found on the outer packaging for this package.
<b>Note:</b>	In the event the full Microchip part number cannot be marked on one line, it will be carried over to the next line, thus limiting the number of available characters for customer-specific information. Package may or may not include the corporate logo.	

## 80-Lead QFN Package Outline (K6)

11.00x11.00mm body, 1.00mm height (max), 0.50mm pitch

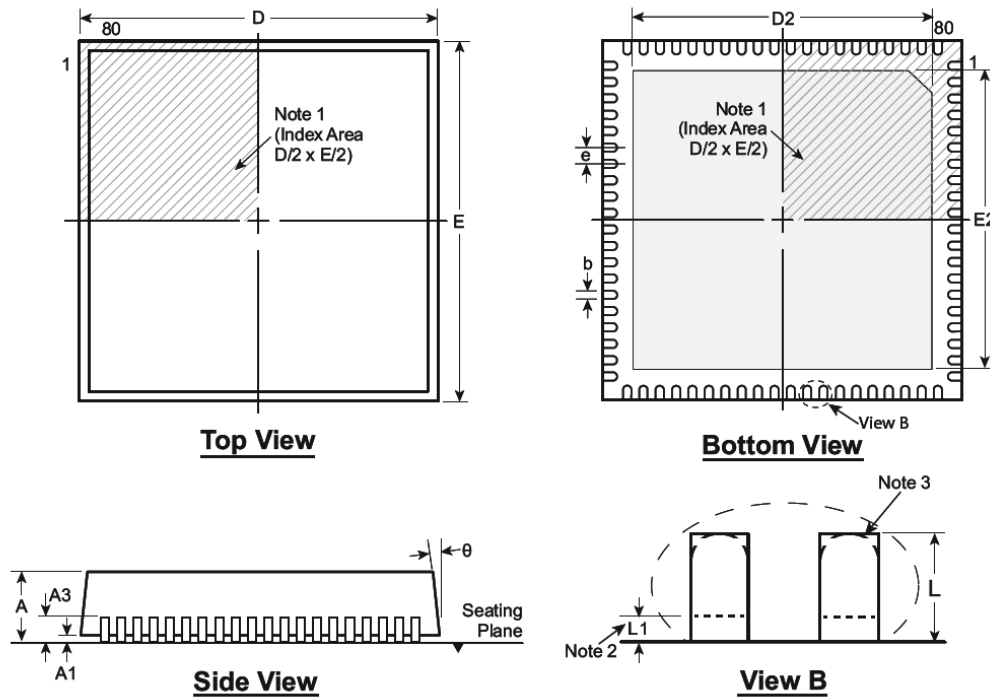

Note: For the most current package drawings, see the Microchip Packaging Specification at [www.microchip.com/packaging](http://www.microchip.com/packaging).

### Notes:

1. A Pin 1 identifier must be located in the index area indicated. The Pin 1 identifier can be: a molded mark/identifier; an embedded metal marker; or a printed indicator.
2. Depending on the method of manufacturing, a maximum of 0.15mm pullback (L1) may be present.
3. The inner tip of the lead may be either rounded or square.

Symbol	A	A1	A3	b	D	D2	E	E2	e	L	L1	θ	
Dimension (mm)	MIN	0.80	0.00	0.20 REF	0.18	10.90	9.50	10.90	9.50	0.50 BSC	0.30	0.00	0°
	NOM	0.90	0.02		0.25	11.00	9.65	11.00	9.65		0.40	-	-
	MAX	1.00	0.05		0.30	11.10	9.75	11.10	9.75		0.50	0.15	14°

Drawings are not to scale.

## APPENDIX A: REVISION HISTORY

### Revision A (June 2015)

- Original Release of this Document.

# HV7351

---

NOTES:

## PRODUCT IDENTIFICATION SYSTEM

To order or obtain information, e.g., on pricing or delivery, refer to the factory or the listed sales office.

<u>PART NO.</u>	<u>XX</u>	<u>-X</u>
Device	Package	Environmental
<b>Device:</b>	HV7351: Programmable High-Voltage, Ultrasound-Transmit Beamformer	
<b>Package:</b>	K6 = Very Thin Plastic Quad Flat Pack, No Lead Package – 11.00x11.00x1.0 mm Body, 0.50 mm Pitch, 80-Lead (VQFN)	
<b>Environmental:</b>	G = Lead (Pb)-free/ROHS-compliant package	

**Examples:**

a) HV7351K6-G: Programmable High-Voltage Ultrasound-Transmit Beamformer, 80LD 11x11 mm VQFN package

# HV7351

---

NOTES:



---

**Note the following details of the code protection feature on Microchip devices:**

- Microchip products meet the specification contained in their particular Microchip Data Sheet.
- Microchip believes that its family of products is one of the most secure families of its kind on the market today, when used in the intended manner and under normal conditions.
- There are dishonest and possibly illegal methods used to breach the code protection feature. All of these methods, to our knowledge, require using the Microchip products in a manner outside the operating specifications contained in Microchip's Data Sheets. Most likely, the person doing so is engaged in theft of intellectual property.
- Microchip is willing to work with the customer who is concerned about the integrity of their code.
- Neither Microchip nor any other semiconductor manufacturer can guarantee the security of their code. Code protection does not mean that we are guaranteeing the product as “unbreakable.”

Code protection is constantly evolving. We at Microchip are committed to continuously improving the code protection features of our products. Attempts to break Microchip's code protection feature may be a violation of the Digital Millennium Copyright Act. If such acts allow unauthorized access to your software or other copyrighted work, you may have a right to sue for relief under that Act.

---

Information contained in this publication regarding device applications and the like is provided only for your convenience and may be superseded by updates. It is your responsibility to ensure that your application meets with your specifications. MICROCHIP MAKES NO REPRESENTATIONS OR WARRANTIES OF ANY KIND WHETHER EXPRESS OR IMPLIED, WRITTEN OR ORAL, STATUTORY OR OTHERWISE, RELATED TO THE INFORMATION, INCLUDING BUT NOT LIMITED TO ITS CONDITION, QUALITY, PERFORMANCE, MERCHANTABILITY OR FITNESS FOR PURPOSE. Microchip disclaims all liability arising from this information and its use. Use of Microchip devices in life support and/or safety applications is entirely at the buyer's risk, and the buyer agrees to defend, indemnify and hold harmless Microchip from any and all damages, claims, suits, or expenses resulting from such use. No licenses are conveyed, implicitly or otherwise, under any Microchip intellectual property rights.

**Trademarks**

The Microchip name and logo, the Microchip logo, dsPIC, FlashFlex, flexPWR, JukeBlox, KEELOQ, KEELOQ logo, Klear, LANCheck, MediaLB, MOST, MOST logo, MPLAB, OptoLyzer, PIC, PICSTART, PIC<sup>32</sup> logo, RightTouch, SpyNIC, SST, SST Logo, SuperFlash and UNI/O are registered trademarks of Microchip Technology Incorporated in the U.S.A. and other countries.

The Embedded Control Solutions Company and mTouch are registered trademarks of Microchip Technology Incorporated in the U.S.A.

Analog-for-the-Digital Age, BodyCom, chipKIT, chipKIT logo, CodeGuard, dsPICDEM, dsPICDEM.net, ECAN, In-Circuit Serial Programming, ICSP, Inter-Chip Connectivity, KlearNet, KlearNet logo, MiWi, MPASM, MPF, MPLAB Certified logo, MPLIB, MPLINK, MultiTRAK, NetDetach, Omniscient Code Generation, PICDEM, PICDEM.net, PICkit, PICtail, RightTouch logo, REAL ICE, SQI, Serial Quad I/O, Total Endurance, TSHARC, USBCheck, VariSense, ViewSpan, WiperLock, Wireless DNA, and ZENA are trademarks of Microchip Technology Incorporated in the U.S.A. and other countries.

SQTP is a service mark of Microchip Technology Incorporated in the U.S.A.

Silicon Storage Technology is a registered trademark of Microchip Technology Inc. in other countries.

GestIC is a registered trademarks of Microchip Technology Germany II GmbH & Co. KG, a subsidiary of Microchip Technology Inc., in other countries.

All other trademarks mentioned herein are property of their respective companies.

© 2015, Microchip Technology Incorporated, Printed in the U.S.A., All Rights Reserved.

ISBN: 978-1-63277-402-6

**QUALITY MANAGEMENT SYSTEM**  
**CERTIFIED BY DNV**  
**== ISO/TS 16949 ==**

*Microchip received ISO/TS-16949:2009 certification for its worldwide headquarters, design and wafer fabrication facilities in Chandler and Tempe, Arizona; Gresham, Oregon and design centers in California and India. The Company's quality system processes and procedures are for its PIC® MCUs and dsPIC® DSCs, KEELOQ® code hopping devices, Serial EEPROMs, microperipherals, nonvolatile memory and analog products. In addition, Microchip's quality system for the design and manufacture of development systems is ISO 9001:2000 certified.*



# MICROCHIP

## Worldwide Sales and Service

### AMERICAS

#### Corporate Office

2355 West Chandler Blvd.  
Chandler, AZ 85224-6199

Tel: 480-792-7200

Fax: 480-792-7277

Technical Support:

[http://www.microchip.com/  
support](http://www.microchip.com/support)

Web Address:

[www.microchip.com](http://www.microchip.com)

#### Atlanta

Duluth, GA

Tel: 678-957-9614

Fax: 678-957-1455

#### Austin, TX

Tel: 512-257-3370

#### Boston

Westborough, MA

Tel: 774-760-0087

Fax: 774-760-0088

#### Chicago

Itasca, IL

Tel: 630-285-0071

Fax: 630-285-0075

#### Cleveland

Independence, OH

Tel: 216-447-0464

Fax: 216-447-0643

#### Dallas

Addison, TX

Tel: 972-818-7423

Fax: 972-818-2924

#### Detroit

Novi, MI

Tel: 248-848-4000

#### Houston, TX

Tel: 281-894-5983

Indianapolis

#### Noblesville, IN

Tel: 317-773-8323

Fax: 317-773-5453

#### Los Angeles

Mission Viejo, CA

Tel: 949-462-9523

Fax: 949-462-9608

#### New York, NY

Tel: 631-435-6000

#### San Jose, CA

Tel: 408-735-9110

#### Canada - Toronto

Tel: 905-673-0699

Fax: 905-673-6509

### ASIA/PACIFIC

#### Asia Pacific Office

Suites 3707-14, 37th Floor  
Tower 6, The Gateway  
Harbour City, Kowloon

#### Hong Kong

Tel: 852-2943-5100

Fax: 852-2401-3431

#### Australia - Sydney

Tel: 61-2-9868-6733

Fax: 61-2-9868-6755

#### China - Beijing

Tel: 86-10-8569-7000

Fax: 86-10-8528-2104

#### China - Chengdu

Tel: 86-28-8665-5511

Fax: 86-28-8665-7889

#### China - Chongqing

Tel: 86-23-8980-9588

Fax: 86-23-8980-9500

#### China - Dongguan

Tel: 86-769-8702-9880

#### China - Hangzhou

Tel: 86-571-8792-8115

Fax: 86-571-8792-8116

#### China - Hong Kong SAR

Tel: 852-2943-5100

Fax: 852-2401-3431

#### China - Nanjing

Tel: 86-25-8473-2460

Fax: 86-25-8473-2470

#### China - Qingdao

Tel: 86-532-8502-7355

Fax: 86-532-8502-7205

#### China - Shanghai

Tel: 86-21-5407-5533

Fax: 86-21-5407-5066

#### China - Shenyang

Tel: 86-24-2334-2829

Fax: 86-24-2334-2393

#### China - Shenzhen

Tel: 86-755-8864-2200

Fax: 86-755-8203-1760

#### China - Wuhan

Tel: 86-27-5980-5300

Fax: 86-27-5980-5118

#### China - Xian

Tel: 86-29-8833-7252

Fax: 86-29-8833-7256

### ASIA/PACIFIC

#### China - Xiamen

Tel: 86-592-2388138

Fax: 86-592-2388130

#### China - Zhuhai

Tel: 86-756-3210040

Fax: 86-756-3210049

#### India - Bangalore

Tel: 91-80-3090-4444

Fax: 91-80-3090-4123

#### India - New Delhi

Tel: 91-11-4160-8631

Fax: 91-11-4160-8632

#### India - Pune

Tel: 91-20-3019-1500

#### Japan - Osaka

Tel: 81-6-6152-7160

Fax: 81-6-6152-9310

#### Japan - Tokyo

Tel: 81-3-6880-3770

Fax: 81-3-6880-3771

#### Korea - Daegu

Tel: 82-53-744-4301

Fax: 82-53-744-4302

#### Korea - Seoul

Tel: 82-2-554-7200

Fax: 82-2-558-5932 or

82-2-558-5934

#### Malaysia - Kuala Lumpur

Tel: 60-3-6201-9857

Fax: 60-3-6201-9859

#### Malaysia - Penang

Tel: 60-4-227-8870

Fax: 60-4-227-4068

#### Philippines - Manila

Tel: 63-2-634-9065

Fax: 63-2-634-9069

#### Singapore

Tel: 65-6334-8870

Fax: 65-6334-8850

#### Taiwan - Hsin Chu

Tel: 886-3-5778-366

Fax: 886-3-5770-955

#### Taiwan - Kaohsiung

Tel: 886-7-213-7828

#### Taiwan - Taipei

Tel: 886-2-2508-8600

Fax: 886-2-2508-0102

#### Thailand - Bangkok

Tel: 66-2-694-1351

Fax: 66-2-694-1350

### EUROPE

#### Austria - Wels

Tel: 43-7242-2244-39

Fax: 43-7242-2244-393

#### Denmark - Copenhagen

Tel: 45-4450-2828

Fax: 45-4485-2829

#### France - Paris

Tel: 33-1-69-53-63-20

Fax: 33-1-69-30-90-79

#### Germany - Dusseldorf

Tel: 49-2129-3766400

#### Germany - Munich

Tel: 49-89-627-144-0

Fax: 49-89-627-144-44

#### Germany - Pforzheim

Tel: 49-7231-424750

#### Italy - Milan

Tel: 39-0331-742611

Fax: 39-0331-466781

#### Italy - Venice

Tel: 39-049-7625286

#### Netherlands - Drunen

Tel: 31-416-690399

Fax: 31-416-690340

#### Poland - Warsaw

Tel: 48-22-3325737

#### Spain - Madrid

Tel: 34-91-708-08-90

Fax: 34-91-708-08-91

#### Sweden - Stockholm

Tel: 46-8-5090-4654

#### UK - Wokingham

Tel: 44-118-921-5800

Fax: 44-118-921-5820

01/27/15