

FSUSB43 — Low-Power, Two-Port, High-Speed, USB2.0 (480Mbps) Switch

Features

- Over-Voltage Tolerance (OVT) on all USB Ports up to 5.25V without External Components
- Low On Capacitance: 3.7pF Typical
- Low On Resistance: 3.9Ω Typical
- Low Power Consumption: 1μA Maximum
 - 20μA Maximum I_{CCT} over an Expanded Voltage Range ($V_{IN}=1.8V$, $V_{CC}=4.3V$)
- Wide -3db Bandwidth: > 720MHz
- Packaged in 10-Lead MicroPak™ (1.6 x 2.1mm)
- 8kV ESD Rating, >16kV Power/GND ESD Rating
- Power-Off Protection on All Ports when $V_{CC}=0V$
 - D+/D- Pins Tolerate up to 5.25V

Applications

- Cell phone, PDA, Digital Camera, and Notebook
- LCD Monitor, TV, and Set-Top Box

IMPORTANT NOTE:

For additional performance information, please contact analogswitch@fairchildsemi.com.

Description

The FSUSB43 is a bi-directional, low-power, two-port, high-speed, USB2.0 switch. Configured as a double-pole, double-throw (DPDT) switch, it is optimized for switching between two high-speed (480Mbps) sources or a high-speed and full-speed (12Mbps) source.

The FSUSB43 is compatible with the requirements of USB2.0 and features an extremely low on capacitance (C_{ON}) of 3.7pF. The wide bandwidth of this device (720MHz) exceeds the bandwidth needed to pass the third harmonic, resulting in signals with minimum edge and phase distortion. Superior channel-to-channel crosstalk also minimizes interference.

The FSUSB43 contains special circuitry on the switch I/O pins for applications where the V_{CC} supply is powered-off ($V_{CC}=0$), which allows the device to withstand an over-voltage condition. This minimizes current consumption even when the control voltage applied to the SEL pin is lower than the supply voltage (V_{CC}). This feature is especially valuable to mobile applications, such as cell phones, allowing for direct interface with the general-purpose I/Os of the baseband processor. Other applications include switching and connector sharing in portable cell phones, PDAs, digital cameras, printers, and notebook computers.

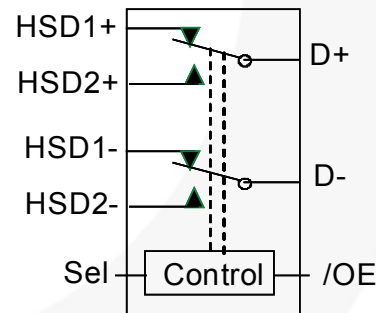

Figure 1. Analog Symbol

Ordering Information

Part Number	Top Mark	Operating Temperature Range	Eco Status	Package
FSUSB43L10X	JH	-40 to +85°C	Green	10-Lead MicroPak™ 1.6 x 2.1mm, JEDEC MO-255B

MicroPak™ is a trademark of Fairchild Semiconductor Corporation.

For Fairchild's definition of Eco Status, please visit: http://www.fairchildsemi.com/company/green/rohs_green.html.

Pin Configuration

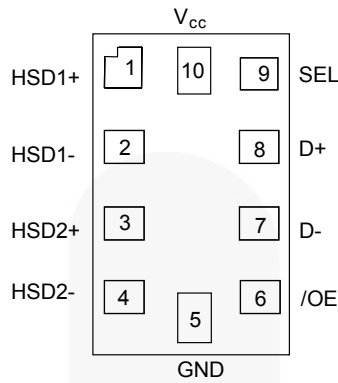

Figure 2. Pin Assignment (Top Through View)

Pin Definitions

Pin #	Name	Description
1	HSD1+	Multiplexed Source Inputs
2	HSD1-	Multiplexed Source Inputs
3	HSD2+	Multiplexed Source Inputs
4	HSD2-	Multiplexed Source Inputs
5	GND	Ground
6	/OE	Switch Enable
7	D-	USB Data Bus
8	D+	USB Data Bus
9	SEL	Switch Select
10	V _{cc}	Supply Voltage

Truth Table

SEL	/OE	Function
X	HIGH	Disconnect
LOW	LOW	D+, D-=HSD1+, HSD1-
HIGH	LOW	D+, D-=HSD2+, HSD2-

Absolute Maximum Ratings

Stresses exceeding the absolute maximum ratings may damage the device. The device may not function or be operable above the recommended operating conditions and stressing the parts to these levels is not recommended. In addition, extended exposure to stresses above the recommended operating conditions may affect device reliability. The absolute maximum ratings are stress ratings only.

Symbol	Parameter	Min.	Max.	Unit	
V _{CC}	Supply Voltage	-0.5	+5.5	V	
V _{CNTRL}	DC Input Voltage (Sel, /OE) ⁽¹⁾	-0.5	V _{CC}	V	
V _{SW}	ALL PINS for V _{CC} 0 to 5.5V	-0.5	5.5	V	
I _{IK}	DC Input Diode Current	-50		mA	
I _{OUT}	DC Output Current		100	mA	
T _{STG}	Storage Temperature	-65	+150	°C	
ESD	Human Body Model: JEDEC JESD22-A114	All Pins		8	kV
		I/O to GND		9	
		Power to GND		16	
	Charged Device Model: JEDEC JESD22-C101			2	

Note:

- The input and output negative ratings may be exceeded if the input and output diode current ratings are observed.

Recommended Operating Conditions

The Recommended Operating Conditions table defines the conditions for actual device operation. Recommended operating conditions are specified to ensure optimal performance to the datasheet specifications. Fairchild does not recommend exceeding them or designing to Absolute Maximum Ratings.

Symbol	Parameter	Min.	Max.	Unit
V _{CC}	Supply Voltage	3.0	4.3	V
V _{CNTRL}	Control Input Voltage ⁽²⁾ (Sel, /OE)	0	V _{CC}	V
V _{SW}	Switch I/O Voltage	-0.5	4.5	V
T _A	Operating Temperature	-40	+85	°C

Note:

- The control input must be held HIGH or LOW; it must not float.

DC Electrical Characteristics

All typical values are at 25°C unless otherwise specified.

Symbol	Parameter	Conditions	V _{CC} (V)	T _A =- 40°C to +85°C			Units
				Min.	Typ.	Max.	
V _{IK}	Clamp Diode Voltage	I _{IN} =-18mA	3.0			-1.2	V
V _{IH}	Input Voltage High		3.0 to 3.6	1.3			V
			4.3	1.7			V
V _{IL}	Input Voltage Low		3.0 to 3.6			0.5	V
			4.3			0.7	V
I _{IN}	Control Input Leakage	V _{SW} =0 to V _{CC}	4.3	-1.0		1.0	μA
I _{OZ}	Off State Leakage	0 ≤ Dn, HSD1n, HSD2n ≤ 3.6V	4.3	-2.0		2.0	μA
I _{OFF}	Power-Off Leakage Current (All I/O Ports)	V _{SW} =0V to 4.3V, V _{CC} =0V Figure 4	0	-2		2	μA
R _{ON}	HS Switch On Resistance ⁽³⁾	V _{SW} =0.4V, I _{ON} =-8mA Figure 3	3.0		3.9	6.5	Ω
ΔR _{ON}	HS Delta R _{ON} ⁽⁴⁾	V _{SW} =0.4V, I _{ON} =-8mA	3.0		0.65		Ω
I _Q	Quiescent Supply Current	V _{CNTRL} =0 or V _{CC} , I _{OUT} =0	4.3			1.0	μA
I _{CCT}	Increase in I _Q Current per Control Voltage and V _{CC}	V _{CNTRL} =2.6V, V _{CC} =4.3V	4.3			10.0	μA
		V _{CNTRL} =1.8V, V _{CC} =4.3V	4.3			20.0	μA

Notes:

- Measured by the voltage drop between HSDn and Dn pins at the indicated current through the switch. On resistance is determined by the lower of the voltage on the two (HSDn or Dn ports).
- Guaranteed by characterization.

AC Electrical Characteristics

All typical values are for $V_{CC}=3.3V$ at $25^{\circ}C$ unless otherwise specified.

Symbol	Parameter	Conditions	V_{CC} (V)	$T_A=-40^{\circ}C$ to $+85^{\circ}C$			Units
				Min.	Typ.	Max.	
t_{ON}	Turn-On Time SEL, /OE to Output	$R_L=50\Omega$, $C_L=5pF$, $V_{SW}=0.8V$ Figure 5, Figure 6	3.0 to 3.6		13	30	ns
t_{OFF}	Turn-Off Time SEL, /OE to Output	$R_L=50\Omega$, $C_L=5pF$, $V_{SW}=0.8V$ Figure 5, Figure 6	3.0 to 3.6		12	25	ns
t_{PD}	Propagation Delay ⁽⁵⁾	$R_L=50\Omega$, $C_L=5pF$ Figure 5, Figure 7	3.3		0.25		ns
t_{BBM}	Break-Before-Make Time ⁽⁵⁾	$R_L=50\Omega$, $C_L=5pF$ $V_{SW1}=V_{SW2}=0.8V$ Figure 9	3.0 to 3.6	2.0		6.5	ns
OIRR	Off Isolation ⁽⁵⁾	$R_L=50\Omega$, $f=240MHz$ Figure 11	3.0 to 3.6		-30		dB
Xtalk	Non-Adjacent Channel Crosstalk ⁽⁵⁾	$R_L=50\Omega$, $f=240MHz$ Figure 12	3.0 to 3.6		-45		dB
BW	-3db Bandwidth ⁽⁵⁾	$R_L=50\Omega$, $C_L=0pF$ Figure 10	3.0 to 3.6		720		MHz
		$R_L=50\Omega$, $C_L=5pF$ Figure 10			550		MHz

Note:

5. Guaranteed by characterization.

USB High-Speed-Related AC Electrical Characteristics

Symbol	Parameter	Conditions	V_{CC} (V)	$T_A=-40^{\circ}C$ to $+85^{\circ}C$			Units
				Min.	Typ.	Max.	
$t_{SK(P)}$	Skew of Opposite Transitions of the Same Output ⁽⁶⁾	$R_L=50\Omega$, $C_L=5pF$ Figure 8	3.0 to 3.6		20		ps
t_J	Total Jitter ⁽⁶⁾	$R_L=50\Omega$, $C_L=5pF$, $t_r=t_f=500ps$ (10-90%) at 480Mbps, (PRBS= $2^{15}-1$)	3.0 to 3.6		200		ps

Note:

6. Guaranteed by characterization.

Capacitance

Symbol	Parameter	Conditions	$T_A=-40^{\circ}C$ to $+85^{\circ}C$			Units
			Min.	Typ.	Max.	
C_{IN}	Control Pin Input Capacitance ⁽⁷⁾	$V_{CC}=0V$		1.5		pF
C_{ON}	D+/D- On Capacitance ⁽⁷⁾	$V_{CC}=3.3V$, /OE=0V, $f=240MHz$ Figure 14		3.7		
C_{OFF}	D1n, D2n Off Capacitance ⁽⁷⁾	V_{CC} and /OE=3.3V Figure 13		2.0		

Note:

7. Guaranteed by characterization.

Test Diagrams

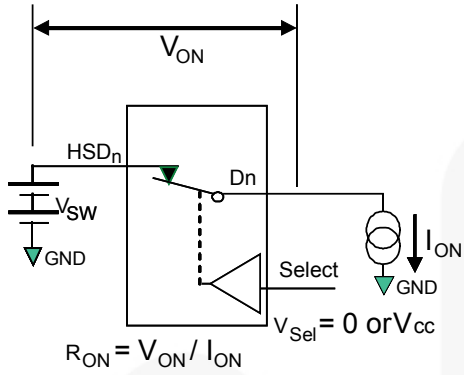
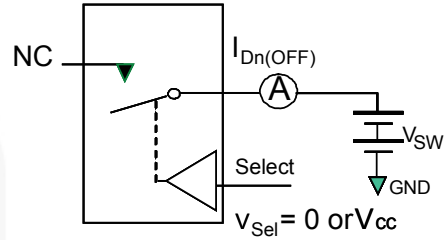
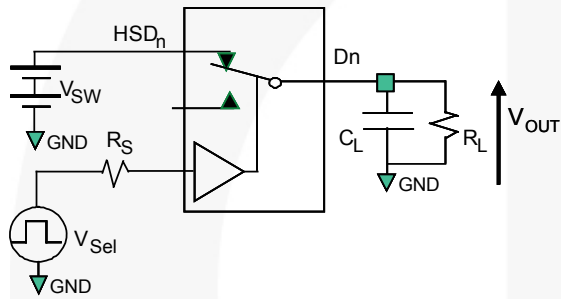

Figure 3. On Resistance



**Each switch port is tested separately

Figure 4. Off Leakage



R_L , R_S , and C_L are functions of the application environment (see AC Tables for specific values)
 C_L includes test fixture and stray capacitance.

Figure 5. AC Test Circuit Load

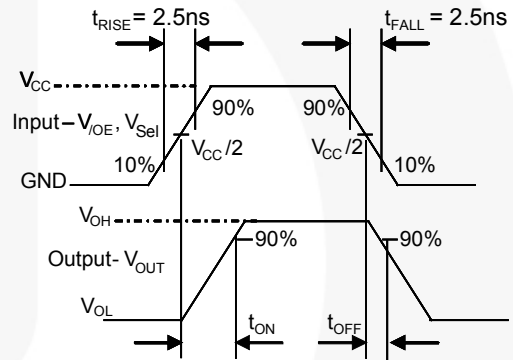

Figure 6. Turn-On / Turn-Off Waveforms

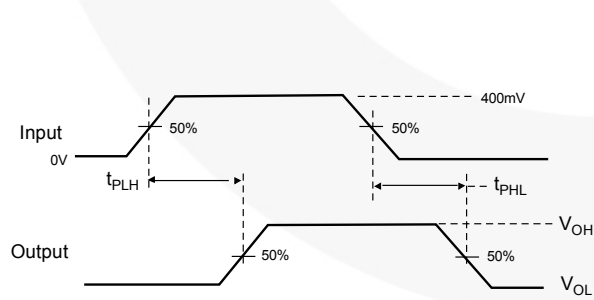

Figure 7. Propagation Delay ($t_{tr} = 500ps$)

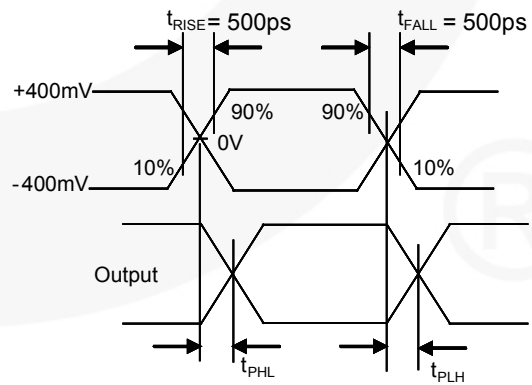
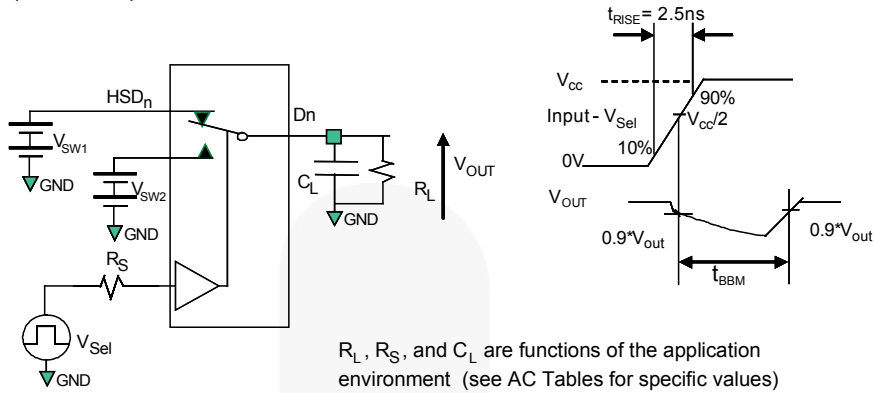

Figure 8. Intra-Pair Skew Test $t_{SK(P)}$

Test Diagrams (Continued)



R_L , R_S , and C_L are functions of the application environment (see AC Tables for specific values)
 C_L includes test fixture and stray capacitance.

Figure 9. Break-Before-Make Interval Timing

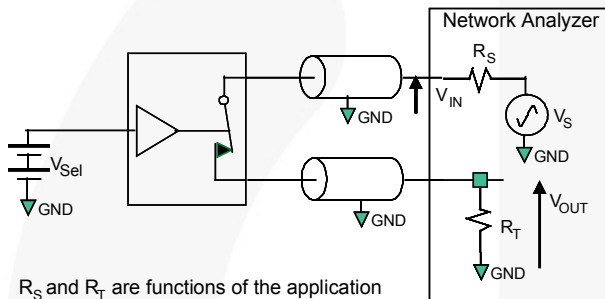

R_S and R_T are functions of the application environment (see AC Tables for specific values).

Figure 10. Bandwidth

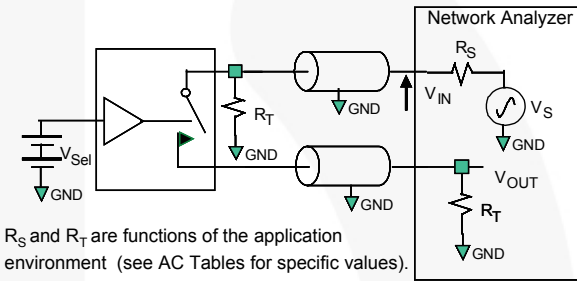

R_S and R_T are functions of the application environment (see AC Tables for specific values).

Off isolation = $20 \text{ Log } (V_{OUT} / V_{IN})$

Figure 11. Channel Off Isolation

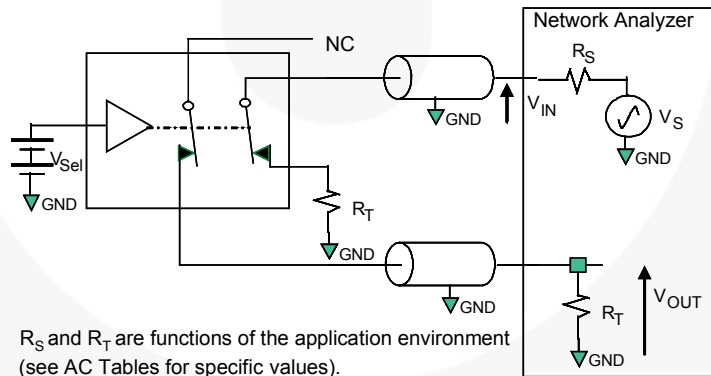

R_S and R_T are functions of the application environment (see AC Tables for specific values).

Crosstalk = $20 \text{ Log } (V_{OUT} / V_{IN})$

Figure 12. Non-Adjacent Channel-to-Channel Crosstalk

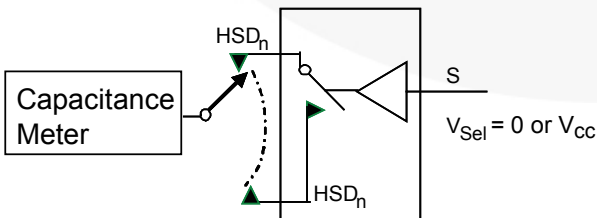

Figure 13. Channel Off Capacitance

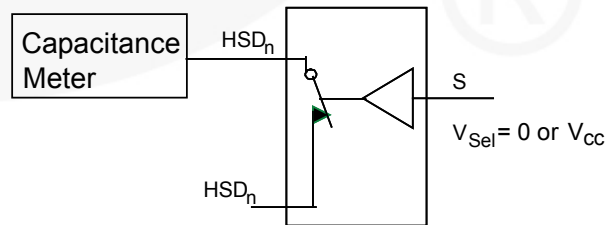

Figure 14. Channel On Capacitance

Physical Dimensions

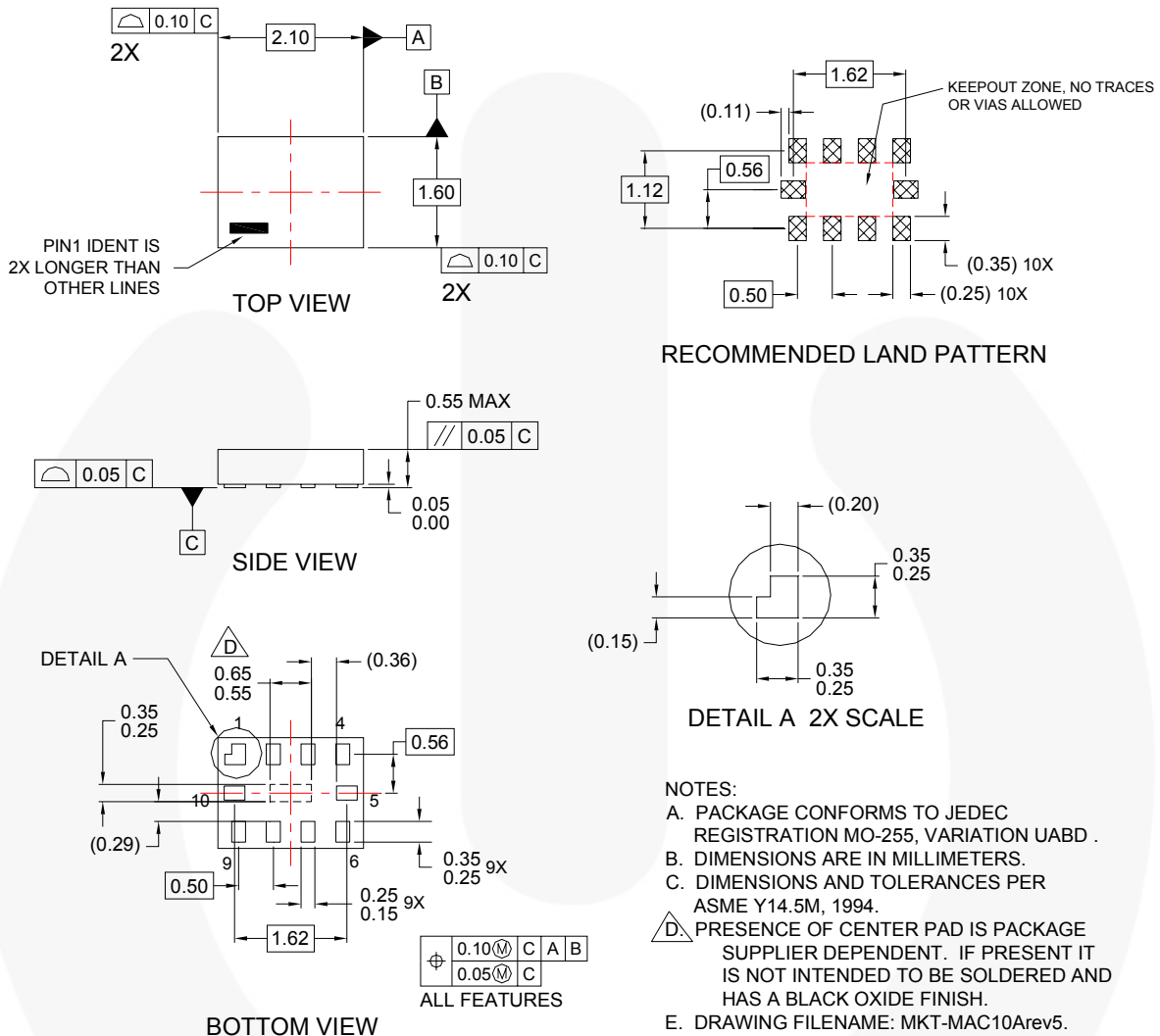

Figure 15. 10-Lead MicroPak™

Package drawings are provided as a service to customers considering Fairchild components. Drawings may change in any manner without notice. Please note the revision and/or date on the drawing and contact a Fairchild Semiconductor representative to verify or obtain the most recent revision. Package specifications do not expand the terms of Fairchild's worldwide terms and conditions, specifically the warranty therein, which covers Fairchild products.

Always visit Fairchild Semiconductor's online packaging area for the most recent package drawings:
<http://www.fairchildsemi.com/packaging/>.

For current tape and reel specifications, visit Fairchild Semiconductor's online packaging area:
http://www.fairchildsemi.com/products/logic/pdf/micropak_tr.pdf.



TRADEMARKS

The following includes registered and unregistered trademarks and service marks, owned by Fairchild Semiconductor and/or its global subsidiaries, and is not intended to be an exhaustive list of all such trademarks.

- | | | | |
|--------------------------|--------------------------|---------------------------------------|---|
| AccuPower™ | FlashWriter®* | PDP SPM™ | SYSTEM GENERAL®
The Power Franchise® |
| Auto-SPM™ | FPS™ | Power-SPM™ | the power franchise |
| Build it Now™ | F-PFS™ | PowerTrench® | TinyBoost™ |
| CorePLUS™ | FRFET® | PowerXS™ | TinyBuck™ |
| CorePOWER™ | Global Power Resource SM | Programmable Active Droop™ | TinyCalc™ |
| CROSSVOLT™ | Green FPS™ | QFET® | TinyLogic® |
| CTL™ | Green FPS™ e-Series™ | QS™ | TINYOPTO™ |
| Current Transfer Logic™ | Gmax™ | Quiet Series™ | TinyPower™ |
| DEUXPEED® | GTO™ | RapidConfigure™ | TinyPWM™ |
| Dual Cool™ | IntelliMAX™ | ™ | TinyWire™ |
| EcoSPARK® | ISOPLANAR™ | Saving our world, 1mW/W/KW at a time™ | TriFault Detect™ |
| EfficientMax™ | MegaBuck™ | SignalWise™ | TRUECURRENT™* |
| EZSWITCH™* | MICROCOUPLER™ | SmartMax™ | μSerDes™ |
| ™ | MicroFET™ | SMART START™ | SerDes™ |
| ™ | MicroPak™ | SPM® | UHC® |
| Fairchild® | MicroPak2™ | STEALTH™ | Ultra FRFET™ |
| Fairchild Semiconductor® | MillerDrive™ | SuperFET™ | UniFET™ |
| FACT Quiet Series™ | MotionMax™ | SuperSOT™-3 | Vcx™ |
| FACT® | Motion-SPM™ | SuperSOT™-6 | VisualMax™ |
| FAST® | OptoHIT™ | SuperSOT™-8 | XST™ |
| FastvCore™ | OPTOLOGIC® | SupreMOS™ | |
| FETBench™ | OPTOPLANAR® | SyncFET™ | |
| | | Sync-Lock™ | |

* Trademarks of System General Corporation, used under license by Fairchild Semiconductor.

DISCLAIMER

FAIRCHILD SEMICONDUCTOR RESERVES THE RIGHT TO MAKE CHANGES WITHOUT FURTHER NOTICE TO ANY PRODUCTS HEREIN TO IMPROVE RELIABILITY, FUNCTION, OR DESIGN. FAIRCHILD DOES NOT ASSUME ANY LIABILITY ARISING OUT OF THE APPLICATION OR USE OF ANY PRODUCT OR CIRCUIT DESCRIBED HEREIN; NEITHER DOES IT CONVEY ANY LICENSE UNDER ITS PATENT RIGHTS, NOR THE RIGHTS OF OTHERS. THESE SPECIFICATIONS DO NOT EXPAND THE TERMS OF FAIRCHILD'S WORLDWIDE TERMS AND CONDITIONS, SPECIFICALLY THE WARRANTY THEREIN, WHICH COVERS THESE PRODUCTS.

LIFE SUPPORT POLICY

FAIRCHILD'S PRODUCTS ARE NOT AUTHORIZED FOR USE AS CRITICAL COMPONENTS IN LIFE SUPPORT DEVICES OR SYSTEMS WITHOUT THE EXPRESS WRITTEN APPROVAL OF FAIRCHILD SEMICONDUCTOR CORPORATION.

As used herein:

- Life support devices or systems are devices or systems which, (a) are intended for surgical implant into the body or (b) support or sustain life, and (c) whose failure to perform when properly used in accordance with instructions for use provided in the labeling, can be reasonably expected to result in a significant injury of the user.
- A critical component in any component of a life support, device, or system whose failure to perform can be reasonably expected to cause the failure of the life support device or system, or to affect its safety or effectiveness.

ANTI-COUNTERFEITING POLICY

Fairchild Semiconductor Corporation's Anti-Counterfeiting Policy. Fairchild's Anti-Counterfeiting Policy is also stated on our external website, www.fairchildsemi.com, under Sales Support.

Counterfeiting of semiconductor parts is a growing problem in the industry. All manufacturers of semiconductor products are experiencing counterfeiting of their parts. Customers who inadvertently purchase counterfeit parts experience many problems such as loss of brand reputation, substandard performance, failed applications, and increased cost of production and manufacturing delays. Fairchild is taking strong measures to protect ourselves and our customers from the proliferation of counterfeit parts. Fairchild strongly encourages customers to purchase Fairchild parts either directly from Fairchild or from Authorized Fairchild Distributors who are listed by country on our web page cited above. Products customers buy either from Fairchild directly or from Authorized Fairchild Distributors are genuine parts, have full traceability, meet Fairchild's quality standards for handling and storage and provide access to Fairchild's full range of up-to-date technical and product information. Fairchild and our Authorized Distributors will stand behind all warranties and will appropriately address any warranty issues that may arise. Fairchild will not provide any warranty coverage or other assistance for parts bought from Unauthorized Sources. Fairchild is committed to combat this global problem and encourage our customers to do their part in stopping this practice by buying direct or from authorized distributors.

PRODUCT STATUS DEFINITIONS

Definition of Terms

Datasheet Identification	Product Status	Definition
Advance Information	Formative / In Design	Datasheet contains the design specifications for product development. Specifications may change in any manner without notice.
Preliminary	First Production	Datasheet contains preliminary data; supplementary data will be published at a later date. Fairchild Semiconductor reserves the right to make changes at any time without notice to improve design.
No Identification Needed	Full Production	Datasheet contains final specifications. Fairchild Semiconductor reserves the right to make changes at any time without notice to improve the design.
Obsolete	Not In Production	Datasheet contains specifications on a product that is discontinued by Fairchild Semiconductor. The datasheet is for reference information only.

Rev. 146