



REVISION HISTORY

<u>Revision</u>	<u>Description</u>	<u>Issue Date</u>
Rev. 1.0	Initial Issue	Sep.06.2012
Rev. 1.1	Add 25°C & 40°C spec for I _{SB1} & I _{DR} on page 4 & page 9 Delete LL grade for ordering information on page 11	Nov.06.2012
Rev. 1.2	Correct typo error on the column "UB#", "LB#" of truth table for row "Byte Read" "Byte Write" and "Output Disable" at page 4: "X" revised to be "L"	July.08.2013



FEATURES

- Fast access time : 55/70ns
- Low power consumption:
Operating current : 45/30mA (TYP.)
Standby current : 10 μ A (TYP.) SL-version
- Single 2.7V ~ 3.6V power supply
- All inputs and outputs TTL compatible
- Fully static operation
- Tri-state output
- Data byte control :
 - (i) BYTE# fixed to V_{CC}
LB# controlled DQ0 ~ DQ7
UB# controlled DQ8 ~ DQ15
 - (ii) BYTE# fixed to V_{SS}
DQ15 used as address pin, while
DQ8~DQ14 pins not used
- Data retention voltage : 1.2V (MIN.)
- **Green package available**
- Package : 48-pin 12mm x 20mm TSOP-I

GENERAL DESCRIPTION

The LY62L205016A is a 33,554,432-bit low power CMOS static random access memory organized as 2,097,152 words by 16 bits or 4,194,304 words by 8 bits. It is fabricated using very high performance, high reliability CMOS technology. Its standby current is stable within the range of operating temperature.

The LY62L205016A is well designed for low power application, and particularly well suited for battery back-up nonvolatile memory application.

The LY62L205016A operates from a single power supply of 2.7V ~ 3.6V and all inputs and outputs are fully TTL compatible

PRODUCT FAMILY

Product Family	Operating Temperature	Vcc Range	Speed	Power Dissipation	
				Standby(I _{SB1} ,TYP.)	Operating(I _{CC} ,TYP.)
LY62L205016A	0 ~ 70°C	2.7 ~ 3.6V	55/70ns	10 μ A(SL)	45/30mA
LY62L205016A(I)	-40 ~ 85°C	2.7 ~ 3.6V	55/70ns	10 μ A(SL)	45/30mA



FUNCTIONAL BLOCK DIAGRAM

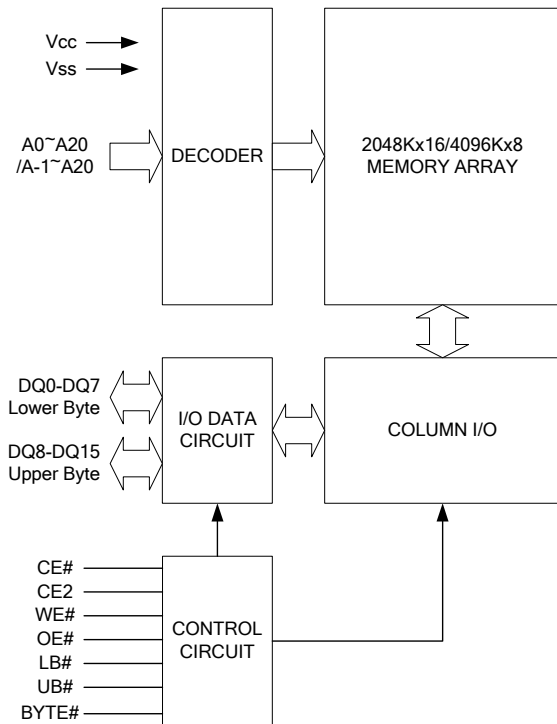

PIN DESCRIPTION

SYMBOL	DESCRIPTION
A0 – A20	Address Inputs(word mode)
A-1 – A20	Address Inputs(byte mode)
DQ0 – DQ15	Data Inputs/Outputs
CE#, CE2	Chip Enable Input
WE#	Write Enable Input
OE#	Output Enable Input
LB#	Lower Byte Control
UB#	Upper Byte Control
BYTE#	Byte Enable
Vcc	Power Supply
Vss	Ground



PIN CONFIGURATION

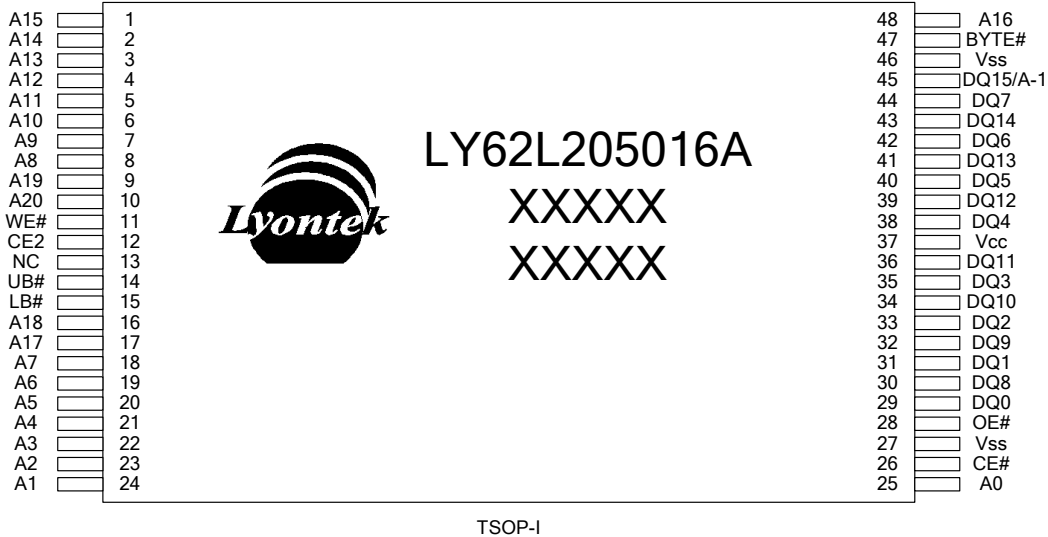

ABSOLUTE MAXIMUM RATINGS*

PARAMETER	SYMBOL	RATING	UNIT
Voltage on Vcc relative to Vss	V _{T1}	-0.5 to 4.6	V
Voltage on any other pin relative to Vss	V _{T2}	-0.5 to V _{CC} +0.5	V
Operating Temperature	T _A	0 to 70(C grade)	°C
		-40 to 85(I grade)	
Storage Temperature	T _{STG}	-65 to 150	°C
Power Dissipation	P _D	1	W
DC Output Current	I _{OUT}	50	mA

*Stresses greater than those listed under "Absolute Maximum Ratings" may cause permanent damage to the device. This is a stress rating only and functional operation of the device or any other conditions above those indicated in the operational sections of this specification is not implied. Exposure to the absolute maximum rating conditions for extended period may affect device reliability.



TRUTH TABLE

MODE	CE#	CE2	BYTE#	OE#	WE#	LB#	UB#	I/O OPERATION			SUPPLY CURRENT
								DQ0-DQ7	DQ8-DQ14	DQ15	
Standby	H	X	X	X	X	X	X	High - Z	High - Z	High - Z	I _{SB} , I _{SB1}
	X	L	X	X	X	X	X	High - Z	High - Z	High - Z	
	X	X	H	X	X	H	H	High - Z	High - Z	High - Z	
Output Disable	L	H	H	H	H	L	X	High - Z	High - Z	High - Z	I _{CC} , I _{CC1}
	L	H	H	H	H	X	L	High - Z	High - Z	High - Z	
	L	H	L	H	H	L	L	High - Z	High - Z	A-1	
Read	L	H	H	L	H	L	H	D _{OUT}	High - Z	High - Z	I _{CC} , I _{CC1}
	L	H	H	L	H	H	L	High - Z	D _{OUT}	D _{OUT}	
	L	H	H	L	H	L	L	D _{OUT}	D _{OUT}	D _{OUT}	
Write	L	H	H	X	L	L	H	D _{IN}	High - Z	High - Z	I _{CC} , I _{CC1}
	L	H	H	X	L	H	L	High - Z	D _{IN}	D _{IN}	
	L	H	H	X	L	L	L	D _{IN}	D _{IN}	D _{IN}	
Byte# Read	L	H	L	L	H	L	L	Dout	High - Z	A-1	I _{CC} , I _{CC1}
Byte # Write	L	H	L	X	L	L	L	Din	High - Z	A-1	I _{CC} , I _{CC1}

Note: H = V_{IH}, L = V_{IL}, X = Don't care.

DC ELECTRICAL CHARACTERISTICS

PARAMETER	SYMBOL	TEST CONDITION	MIN.	TYP. ⁴	MAX.	UNIT		
Supply Voltage	V _{CC}		2.7	3.0	3.6	V		
Input High Voltage	V _{IH} ¹		2.2	-	V _{CC} +0.3	V		
Input Low Voltage	V _{IL} ²		-0.2	-	0.6	V		
Input Leakage Current	I _{LI}	V _{CC} ≥ V _{IN} ≥ V _{SS}	-1	-	1	μA		
Output Leakage Current	I _{LO}	V _{CC} ≥ V _{OUT} ≥ V _{SS} Output Disabled	-1	-	1	μA		
Output High Voltage	V _{OH}	I _{OH} = -1mA	2.2	2.7	-	V		
Output Low Voltage	V _{OL}	I _{OL} = 2mA	-	-	0.4	V		
Average Operating Power supply Current	I _{CC}	Cycle time = Min. CE# = V _{IL} and CE2 = V _{IH} I _{I/O} = 0mA Other pins at V _{IL} or V _{IH}	-55	-	45	80	mA	
			-70	-	30	60	mA	
	I _{CC1}	Cycle time = 1μs CE# ≤ 0.2V and CE2 ≥ V _{CC} -0.2V I _{I/O} = 0mA Other pins at 0.2V or V _{CC} -0.2V	-	10	20	mA		
Standby Power Supply Current	I _{SB}	CE# = V _{IH} or CE2 = V _{IL} Other pins at V _{IL} or V _{IH}	-	0.3	2	mA		
			I _{SB1}	CE# ≥ V _{CC} -0.2V or CE2 ≤ 0.2V Other pins at 0.2V or V _{CC} -0.2V	-SL	25°C	-	10
	-SLI	40°C			-	10	18	μA
	-SL			-	10	80	μA	
	-SLI		-	10	120	μA		

Notes:

- V_{IH}(max) = V_{CC} + 2.0V for pulse width less than 6ns.
- V_{IL}(min) = V_{SS} - 2.0V for pulse width less than 6ns.
- Over/Undershoot specifications are characterized on engineering evaluation stage, not for mass production test.
- Typical values are included for reference only and are not guaranteed or tested.

Typical values are measured at V_{CC} = V_{CC}(TYP.) and T_A = 25°C

Lyontek Inc. reserves the rights to change the specifications and products without notice.

5F, No. 2, Industry E. Rd. IX, Science-Based Industrial Park, Hsinchu 300, Taiwan.

TEL: 886-3-6668838

FAX: 886-3-6668836

**CAPACITANCE (T_A = 25°C, f = 1.0MHz)**

PARAMETER	SYMBOL	MIN.	MAX	UNIT
Input Capacitance	C _{IN}	-	6	pF
Input/Output Capacitance	C _{I/O}	-	8	pF

Note : These parameters are guaranteed by device characterization, but not production tested.

AC TEST CONDITIONS

Input Pulse Levels	0.2V to V _{CC} - 0.2V
Input Rise and Fall Times	3ns
Input and Output Timing Reference Levels	1.5V
Output Load	C _L = 30pF + 1TTL, I _{OH} /I _{OL} = -1mA/2mA

AC ELECTRICAL CHARACTERISTICS**(1) READ CYCLE**

PARAMETER	SYM.	LY62L205016A-55		LY62L205016A-70		UNIT
		MIN.	MAX.	MIN.	MAX.	
Read Cycle Time	t _{RC}	55	-	70	-	ns
Address Access Time	t _{AA}	-	55	-	70	ns
Chip Enable Access Time	t _{ACE}	-	55	-	70	ns
Output Enable Access Time	t _{OE}	-	30	-	35	ns
Chip Enable to Output in Low-Z	t _{CLZ} *	10	-	10	-	ns
Output Enable to Output in Low-Z	t _{OLZ} *	5	-	5	-	ns
Chip Disable to Output in High-Z	t _{CHZ} *	-	20	-	25	ns
Output Disable to Output in High-Z	t _{OHZ} *	-	20	-	25	ns
Output Hold from Address Change	t _{OH}	10	-	10	-	ns
LB#, UB# Access Time	t _{BA}	-	55	-	70	ns
LB#, UB# to High-Z Output	t _{BHZ} *	-	25	-	30	ns
LB#, UB# to Low-Z Output	t _{B LZ} *	10	-	10	-	ns

(2) WRITE CYCLE

PARAMETER	SYM.	LY62L205016A-55		LY62L205016A-70		UNIT
		MIN.	MAX.	MIN.	MAX.	
Write Cycle Time	t _{WC}	55	-	70	-	ns
Address Valid to End of Write	t _{AW}	50	-	60	-	ns
Chip Enable to End of Write	t _{CW}	50	-	60	-	ns
Address Set-up Time	t _{AS}	0	-	0	-	ns
Write Pulse Width	t _{WP}	45	-	55	-	ns
Write Recovery Time	t _{WR}	0	-	0	-	ns
Data to Write Time Overlap	t _{DW}	25	-	30	-	ns
Data Hold from End of Write Time	t _{DH}	0	-	0	-	ns
Output Active from End of Write	t _{OW} *	5	-	5	-	ns
Write to Output in High-Z	t _{WHZ} *	-	20	-	25	ns
LB#, UB# Valid to End of Write	t _{BW}	45	-	60	-	ns

*These parameters are guaranteed by device characterization, but not production tested.



TIMING WAVEFORMS

READ CYCLE 1 (Address Controlled) (1,2)

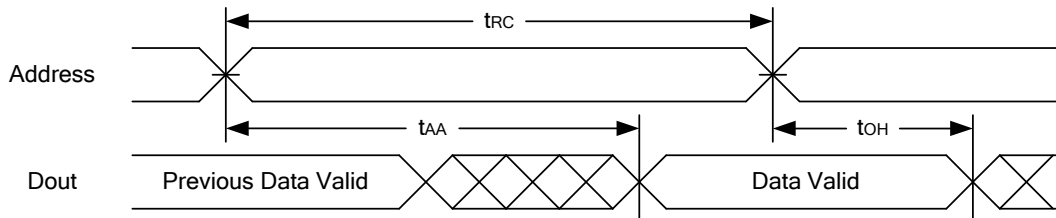

READ CYCLE 2 (CE# and CE2 and OE# Controlled) (1,3,4,5)

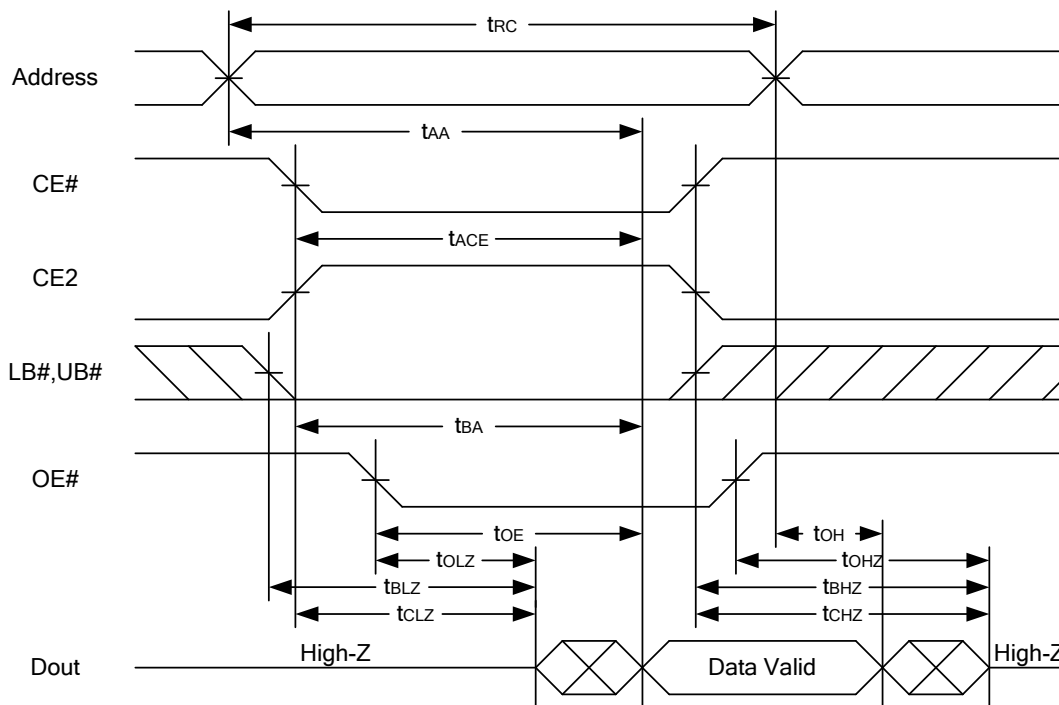

Notes :

1. WE# is high for read cycle.
2. Device is continuously selected OE# = low, CE# = low, CE2 = high, LB# or UB# = low.
3. Address must be valid prior to or coincident with CE# = low, CE2 = high, LB# or UB# = low transition; otherwise t_{AA} is the limiting parameter.
4. t_{CLZ} , t_{BLZ} , t_{OLZ} , t_{CHZ} , t_{BHZ} and t_{OHZ} are specified with $C_L = 5pF$. Transition is measured $\pm 500mV$ from steady state.
5. At any given temperature and voltage condition, t_{CHZ} is less than t_{CLZ} , t_{BHZ} is less than t_{BLZ} , t_{OHZ} is less than t_{OLZ} .



WRITE CYCLE 1 (WE# Controlled) (1,2,3,5,6)

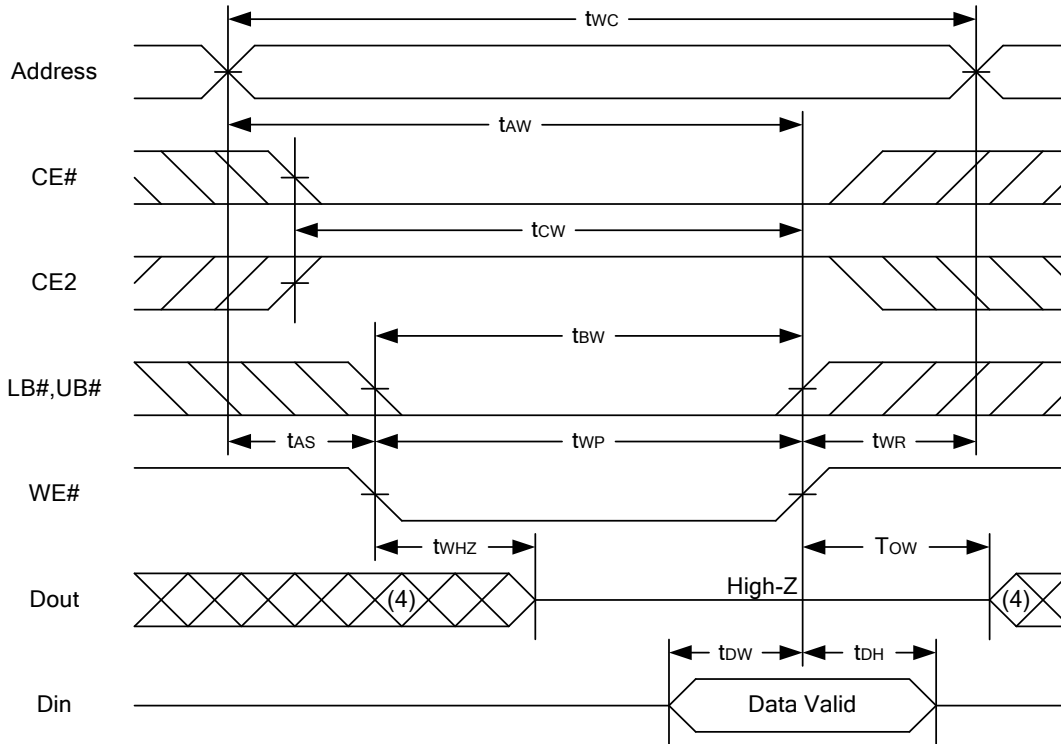

WRITE CYCLE 2 (CE# and CE2 Controlled) (1,2,5,6)

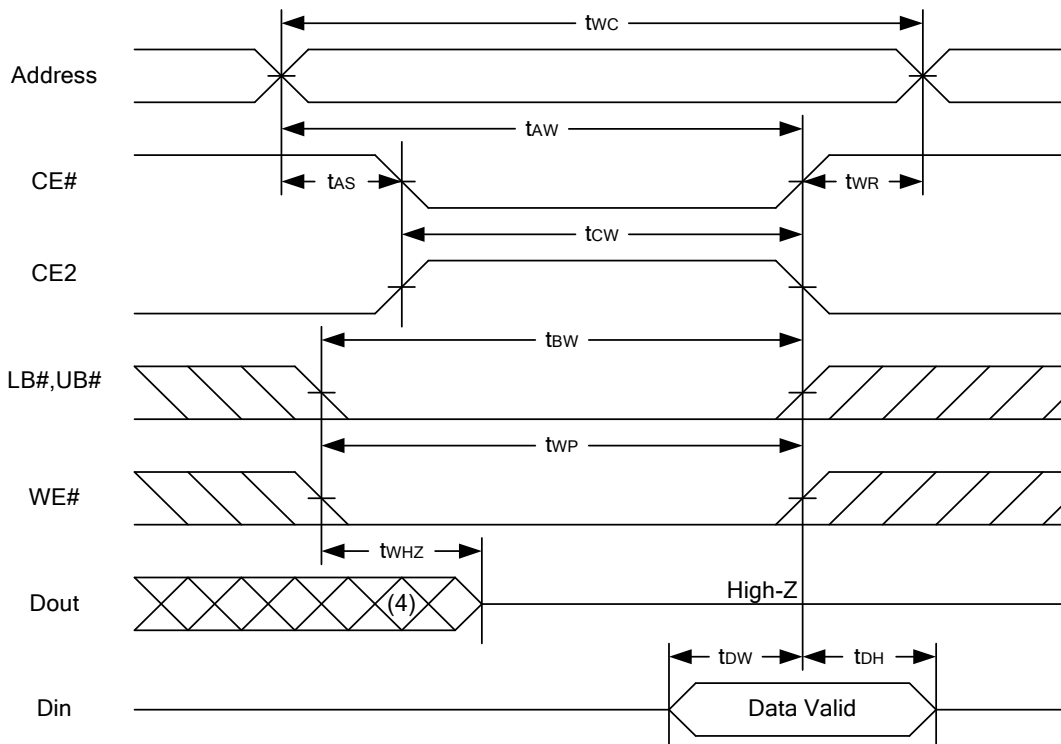



WRITE CYCLE 3 (LB#,UB# Controlled) (1,2,5,6)

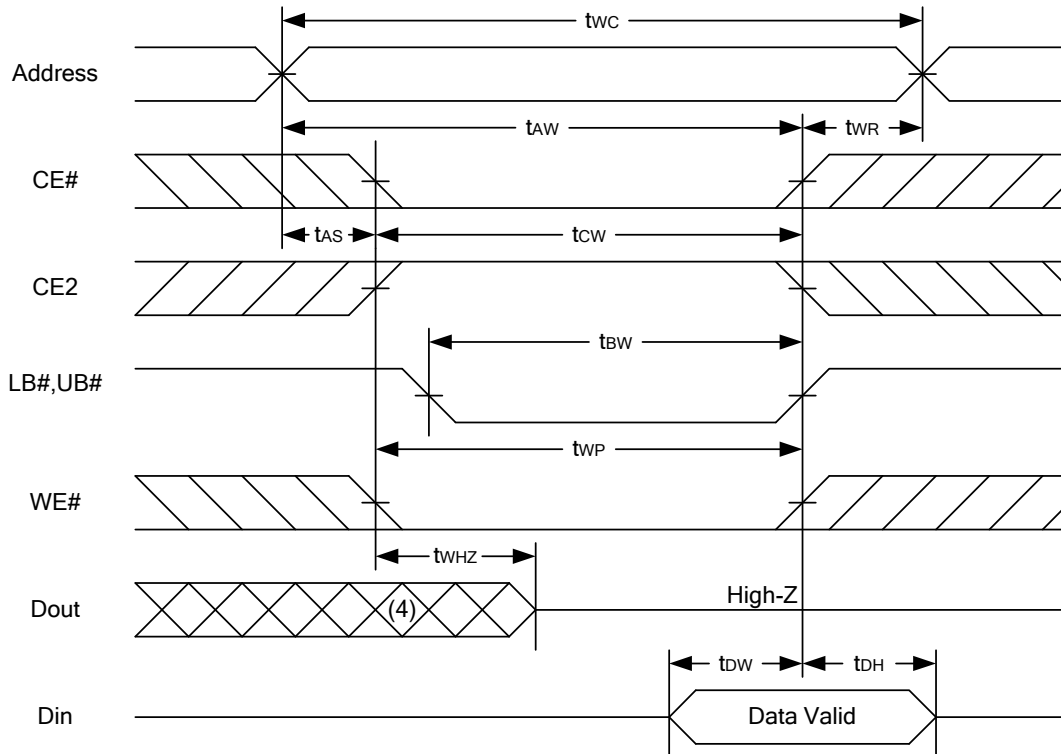

Notes :

1. WE#, CE#, LB#, UB# must be high or CE2 must be low during all address transitions.
2. A write occurs during the overlap of a low CE#, high CE2, low WE#, LB# or UB# = low.
3. During a WE# controlled write cycle with OE# low, t_{WP} must be greater than $t_{WHZ} + t_{DW}$ to allow the drivers to turn off and data to be placed on the bus.
4. During this period, I/O pins are in the output state, and input signals must not be applied.
5. If the CE#, LB#, UB# low transition and CE2 high transition occurs simultaneously with or after WE# low transition, the outputs remain in a high impedance state.
6. t_{ow} and t_{whz} are specified with $C_L = 5pF$. Transition is measured $\pm 500mV$ from steady state.



DATA RETENTION CHARACTERISTICS

PARAMETER	SYMBOL	TEST CONDITION	MIN.	TYP.	MAX.	UNIT	
Vcc for Data Retention	V _{DR}	CE# ≥ V _{CC} - 0.2V or CE2 ≤ 0.2V	1.2	-	3.6	V	
Data Retention Current	I _{DR}	V _{CC} = 1.2V CE# ≥ V _{CC} -0.2V or CE2 ≤ 0.2V other pins at 0.2V or V _{CC} -0.2V	-SL 25°C	-	8	16	μA
			-SLI 40°C	-	8	16	μA
			-SL	-	8	80	μA
			-SLI	-	8	120	μA
Chip Disable to Data Retention Time	t _{CDR}	See Data Retention Waveforms (below)	0	-	-	ns	
Recovery Time	t _R		t _{RC*}	-	-	ns	

t_{RC*} = Read Cycle Time

DATA RETENTION WAVEFORM

Low Vcc Data Retention Waveform (1) (CE# controlled)

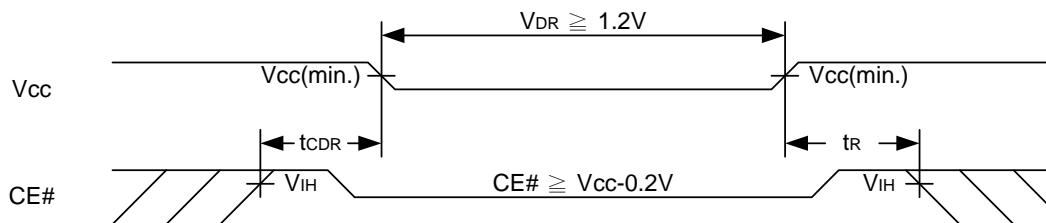

Low Vcc Data Retention Waveform (2) (CE2 controlled)

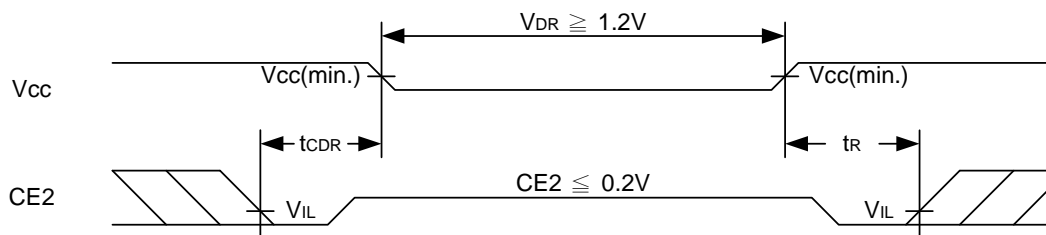

Low Vcc Data Retention Waveform (3) (LB#, UB# controlled)

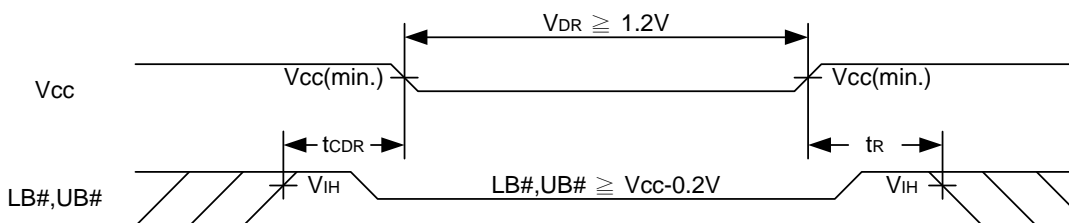

PACKAGE OUTLINE DIMENSION

48-pin 12mm x 20mm TSOP-I Package Outline Dimension

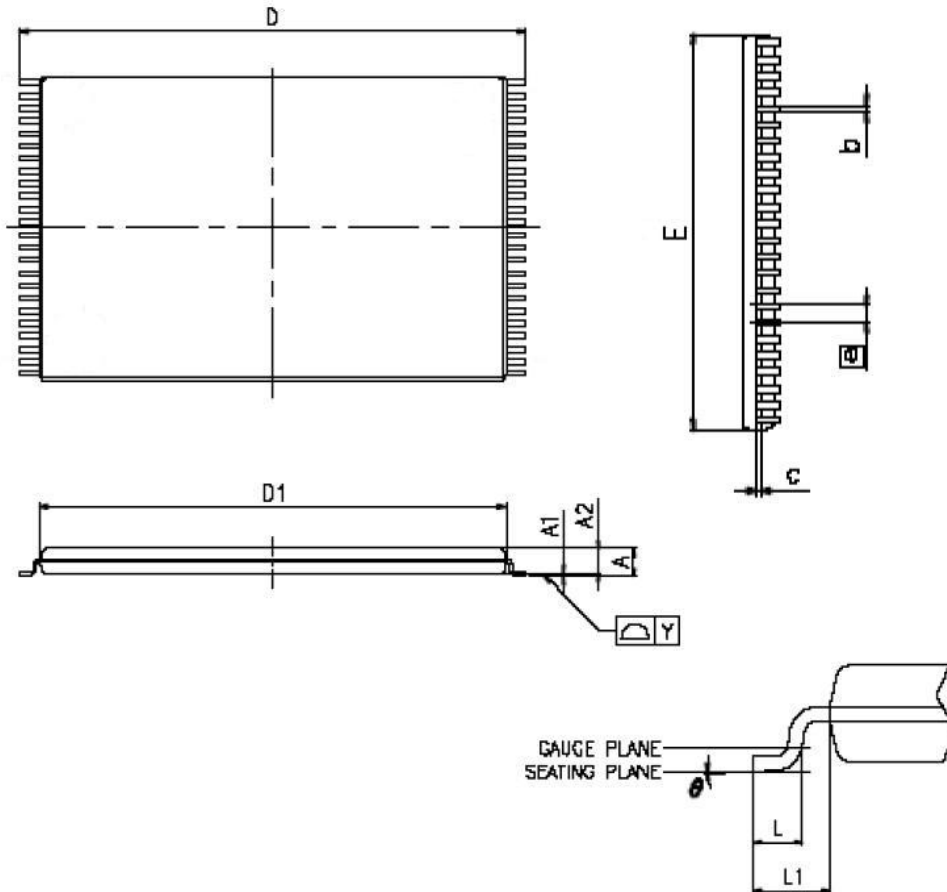

VARIATIONS (ALL DIMENSIONS SHOWN IN MM)

SYMBOLS	MIN.	NOM.	MAX
A	-	-	1.20
A1	0.05	-	0.15
A2	0.95	1.00	1.05
b	0.17	0.22	0.27
c	0.10	-	0.21
D	19.80	20.00	20.20
D1	18.30	18.40	18.50
E	11.90	12.00	12.10
\square	0.50 BASIC		
L	0.50	0.60	0.70
L1	-	0.80	-
Y	-	-	0.10
θ	θ	-	5°

NOTES:

1. JEDEC OUTLINE : MO-142 DD
2. PROFILE TOLERANCE ZONES FOR D1 AND E DO NOT INCLUDE MOLD PROTRUSION. ALLOWABLE MOLD PROTRUSION ON E IS 0.15mm PER SIDE AND ON D1 IS 0.25mm PER SIDE.
3. DIMENSION b DOES NOT INCLUDE DAMBAR PROTRUSION. ALLOWABLE DAMBAR PROTRUSION SHALL BE 0.08mm TOTAL IN EXCESS OF THE b DIMENSION AT MAXIMUM MATERIAL CONDITION. DAMBAR CANNOT BE LOCATED ON THE LOWER RADIUS OR THE FOOT.



ORDERING INFORMATION

Package Type	Access Time (Speed)(ns)	Power Type	Temperature Range(°C)	Packing Type	Lyontek Item No.
48-pin 12mm x 20mm TSOP-I	55	Special Ultra Low Power	0°C~70°C	Tray	LY62L205016ALL-55SL
				Tape Reel	LY62L205016ALL-55SLT
			-40°C~85°C	Tray	LY62L205016ALL-55SLI
				Tape Reel	LY62L205016ALL-55SLIT
	70	Special Ultra Low Power	0°C~70°C	Tray	LY62L205016ALL-70SL
				Tape Reel	LY62L205016ALL-70SLT
			-40°C~85°C	Tray	LY62L205016ALL-70SLI
				Tape Reel	LY62L205016ALL-70SLIT



Lyontek Inc.

LY62L205016A

Rev. 1.2

32M Bits (2Mx16 / 4Mx8 Switchable) LOW POWER CMOS SRAM

THIS PAGE IS LEFT BLANK INTENTIONALLY.