

THIS DRAWING IS UNPUBLISHED. RELEASED FOR PUBLICATION 20
 © COPYRIGHT 20 BY TYCO ELECTRONICS CORPORATION. ALL RIGHTS RESERVED.

| LOC | DIST | REVISIONS | | | | | |
|-----|------|-----------|-----|--------------------------|-----------|-----|------|
| FT | 0 | P | LTR | DESCRIPTION | DATE | DWN | APVD |
| | | 0 | | RELEASED EC 0G3B-0612-04 | 29JUN2005 | SW | CR |
| | | | | | | | |
| | | | | | | | |

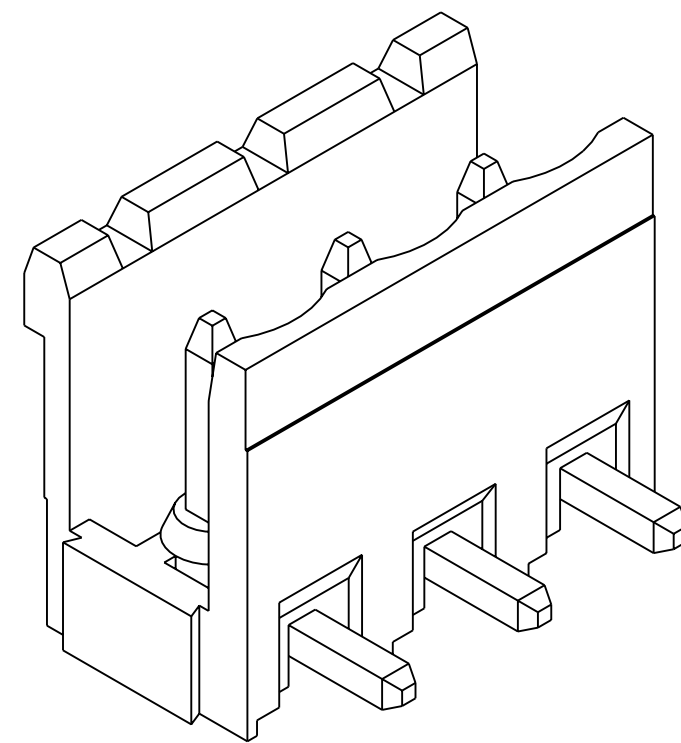
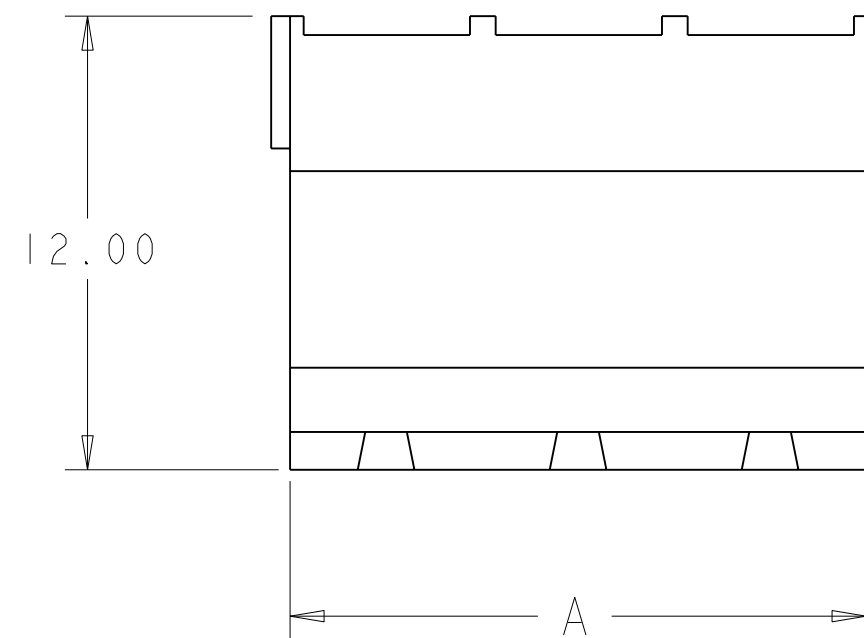

1776145-3 AS SHOWN

- 1. MATERIALS AND FINISH
 HOUSING: HIGH TEMPERATURE POLYAMIDE, UL 94V-0 RATED,
 COLOR: BLACK.
 TERMINAL: PHOSPHOR BRONZE, TIN PLATED.
- 2. SUITABLE FOR 1,6-2,4mm PC BOARD THICKNESS.
- 3. END-TO-END STACKABLE WITHOUT LOSS OF CENTERLINE SPACING.
- 4. RECOGNIZED UNDER THE COMPONENT PROGRAM OF UNDERWRITERS LABORATORIES INC. FILE N° E60677.
- 5. IMQ CERTIFICATE WITH SURVEILLANCE IN CONFORMITY WITH IEC 998-1/998-2-1.
- 6. UL RATING: 300V, 15A.

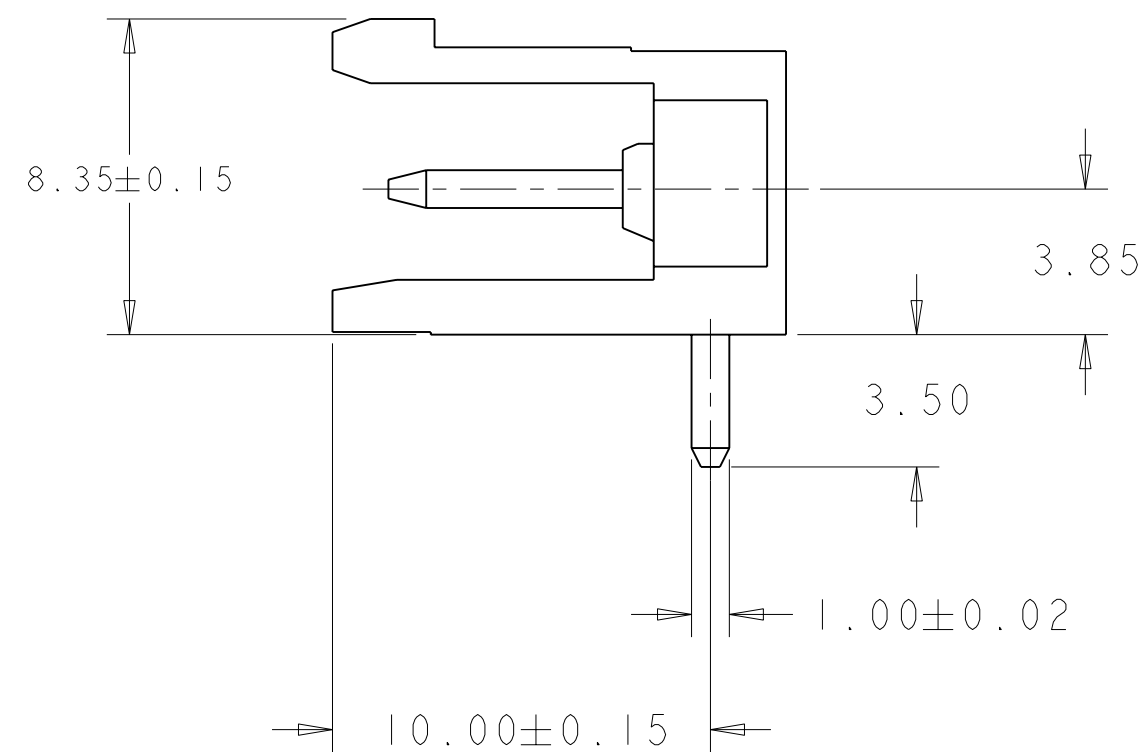
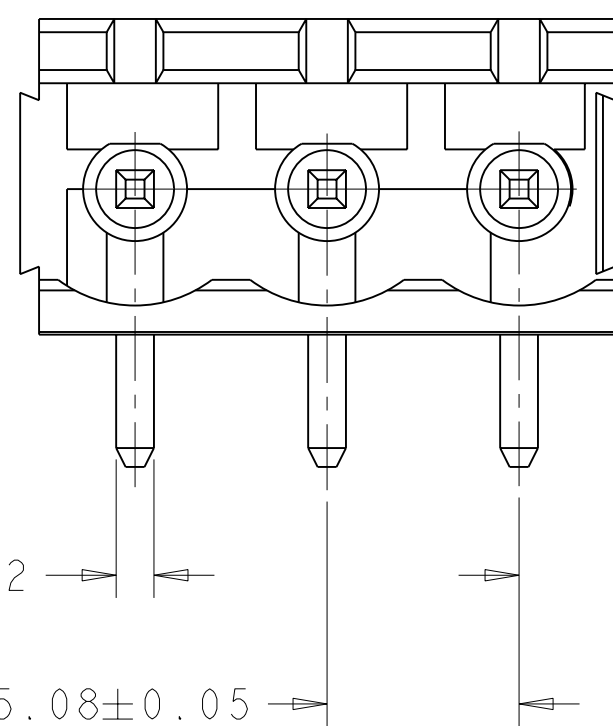

1.00±0.02 2.54 REF
 5.08±0.05

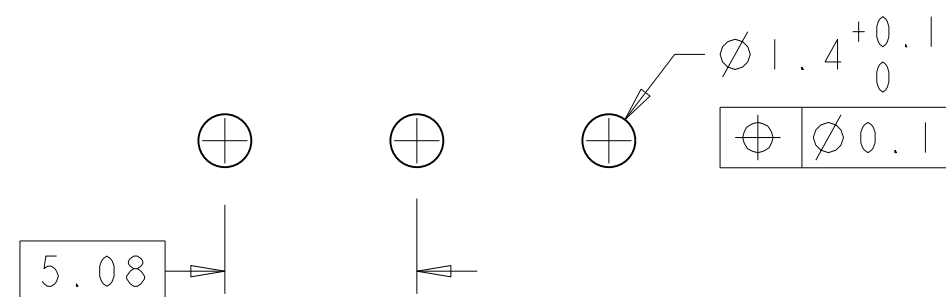

RECOMMENDED PC BOARD LAYOUT

| | | |
|------|------------|-------------|
| 20.0 | 4 | 1776145-4 |
| 15.0 | 3 | 1776145-3 |
| 10.0 | 2 | 1776145-2 |
| A | NO OF POSN | PART NUMBER |

| DIMENSIONS: | | TOLERANCES UNLESS OTHERWISE SPECIFIED: | | DWN | 29JUN2005 | BUCHANAN | | Tyco Electronics | |
|-------------|--|----------------------------------------|------|------------------|------------|--------------------------------|-----------|------------------|---------------|
| mm | | 0 PLC | ±.2 | S. WELDON | 29JUN2005 | Harrisburg, PA 17105-3608 | | | |
| | | 1 PLC | ±.25 | CHK | C. RICHARD | | | | |
| | | 2 PLC | ±.25 | APVD | C. RICHARD | | | | |
| | | 3 PLC | ±. | PRODUCT SPEC | | NAME | | | |
| | | 4 PLC | ±. | 108-20166 | | TERMINAL BLOCK HEADER ASSEMBLY | | | |
| | | ANGLES | ±2 | APPLICATION SPEC | | 90 DEGREE, OPEN ENDS, STACKING | | | |
| | | FINISH | | 114-20079 | | 5.00mm PITCH | | | |
| MATERIAL | | | | WEIGHT | | SIZE | CAGE CODE | DRAWING NO | RESTRICTED TO |
| | | | | | | A2 | 00779 | C=1776145 | - |
| | | | | CUSTOMER DRAWING | | SCALE | 3:1 | SHEET | 1 OF 1 |
| | | | | | | | | | REV 0 |