



Series 811 Mighty Mouse High Density (HD) Jam Nut PCB Receptacle Connectors

811-005-07 and 811-006-07 with PC Tails



Jam Nut PC Tail Receptacles Series 811 Mighty Mouse High Density jam nut PCB receptacles have straight PC tails for termination to flex circuits or rigid boards. These receptacles are backpotted with epoxy. The TwistPin contact system meets requirements of MIL-DTL-83513 and provides outstanding resistance to high levels of shock and vibration. Choose solder-dipped or gold-plated tails. Select 811-006-07 with enhanced waterblocking for open face (unmated) immersion requirements. Molded plastic endcap has standoffs. 3A current rating, 600 VAC dielectric withstanding voltage.

How To Order

Sample Part Number	811-005-07	MT	5-7	P	A	3	-.125
Series	811-005-07 Series 811 rear panel mount jam nut receptacle, straight pc tails, standard epoxy sealing 811-006-07 Series 811 rear panel mount jam nut receptacle, straight pc tails, enhanced water blocking for open face (unmated) water immersion						
Material/Finish*	ME = Aluminum/Electroless Nickel ZNU = Aluminum/Black Zinc-Nickel MT = Aluminum/Nickel-PTFE ZR = Aluminum/Black Zinc-Nickel Z1 = Stainless Steel/Passivated						
Shell Size - Insert Arr.	5-7 = 7 Contacts		7-22 = 22 Contacts		9-42 = 42 Contacts		
Contact Type	P = Pin Contacts S = Socket Contacts						
Key Position	A = Normal Alternate Key Positions: B, C, D, E, F						
PC Tail Finish	3 = Solder-Dipped in 63/37 Tin-Lead			4 = Gold Plated			
PC Tail Length	.090, .125, .250 (Other lengths are readily available)						

* **ZR** plating is RoHS compliant and non-reflective, **ZNU** plating is non-reflective and passes 1,00 hours salt spray testing

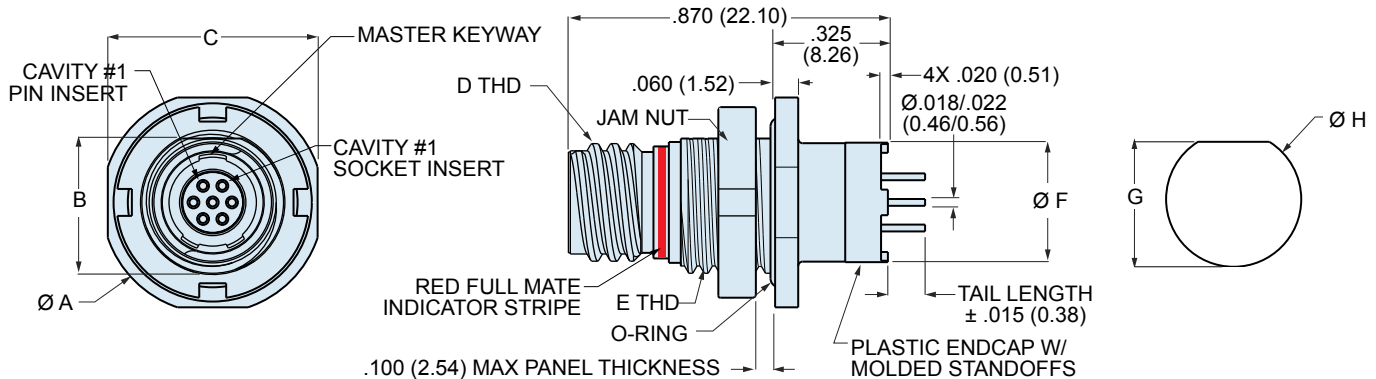

Shell Size	Ø A		B		C		D Thread	E THD UN-2A	Ø F	
	In.	mm.	In.	mm.	In.	mm.			In.	mm.
5	.575	14.61	.350	8.89	.545	13.84	.3125-.05P-.1L-2A	.375-28	.350	8.89
6	.635	16.13	.410	10.41	.602	15.29	.375-.05P-.1L-2A	.4375-28	.490	12.45
7	.755	19.18	.536	13.61	.723	18.36	.4375-.05P-.1L-2A	.5625-32	.600	15.24
8	.755	19.18	.536	13.61	.723	18.36	.5000-.05P-.1L-2A	.5625-32	.670	17.02
9	.830	21.08	.596	15.14	.791	20.09	.5625-.05P-.1L-2A	.625-28	.770	19.56

Shell Size	G		H Ø	
	In.±.002	mm.±0.05	In.±.002	mm.±0.05
5	.356	9.04	.385	9.78
6	.416	10.57	.447	11.35
7	.542	13.77	.572	14.53
8	.542	13.77	.572	14.53
9	.602	15.29	.635	16.13

Dimensions in Inches (millimeters) are subject to change without notice.