



2N60K-MT

Power MOSFET

2A, 600V N-CHANNEL POWER MOSFET

DESCRIPTION

The UTC **2N60K-MT** is a high voltage power MOSFET and is designed to have better characteristics, such as fast switching time, low gate charge, low on-state resistance and have a high rugged avalanche characteristics. This power MOSFET is usually used at high speed switching applications in power supplies, PWM motor controls, high efficient DC to DC converters and bridge circuits.

FEATURES

- * $R_{DS(ON)} < 5.0\Omega @ V_{GS} = 10V, I_D = 1A$
- * Fast switching capability
- * Avalanche energy specified
- * Improved dv/dt capability, high ruggedness

SYMBOL

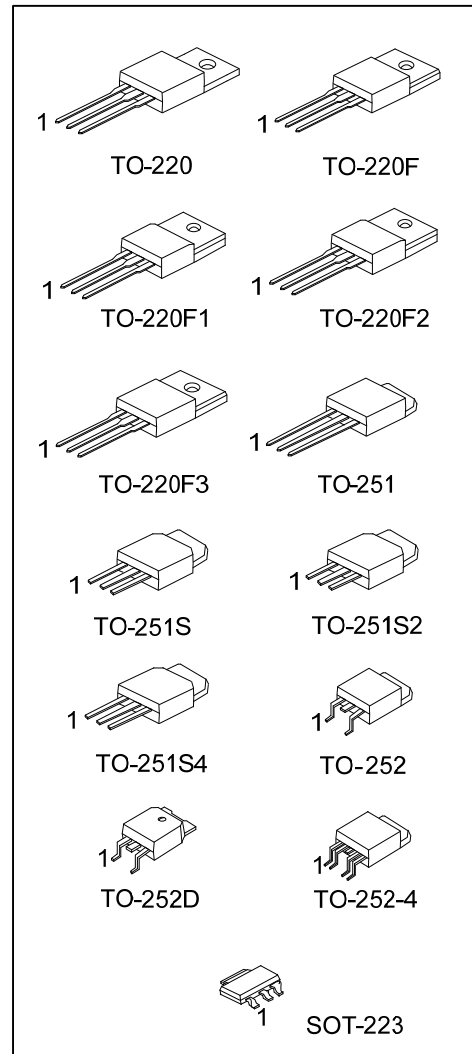
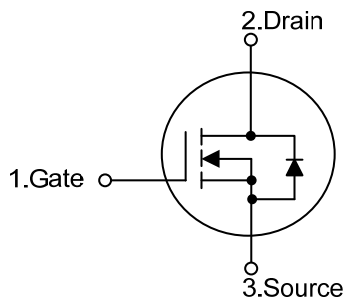

ORDERING INFORMATION

Ordering Number		Package	Pin Assignment					Packing
Lead Free	Halogen Free		1	2	3	4	5	
-	2N60G-AA3-T	SOT-223	G	D	S	-	-	Tape Reel
2N60KL-TA3-T	2N60KG-TA3-T	TO-220	G	D	S	-	-	Tube
2N60KL-TF3-T	2N60KG-TF3-T	TO-220F	G	D	S	-	-	Tube
2N60KL-TF1-T	2N60KG-TF1-T	TO-220F1	G	D	S	-	-	Tube
2N60KL-TF2-T	2N60KG-TF2-T	TO-220F2	G	D	S	-	-	Tube
2N60KL-TF3T-T	2N60KG-TF3T-T	TO-220F3	G	D	S	-	-	Tube
2N60KL-TM3-T	2N60KG-TM3-T	TO-251	G	D	S	-	-	Tube
2N60KL-TMS-T	2N60KG-TMS-T	TO-251S	G	D	S	-	-	Tube
2N60KL-TMS2-T	2N60KG-TMS2-T	TO-251S2	G	D	S	-	-	Tube
2N60KL-TMS4-T	2N60KG-TMS4-T	TO-251S4	G	D	S	-	-	Tube
2N60KL-TN3-R	2N60KG-TN3-R	TO-252	G	D	S	-	-	Tape Reel
2N60KL-TN4-R	2N60KG-TN4-R	TO-252-4	S1	G1	D	S2	G2	Tape Reel
2N60KL-TND-R	2N60KG-TND-R	TO-252D	G	D	S	-	-	Tape Reel

Note: Pin Assignment: G: Gate D: Drain S: Source

	<p>(1) T: Tube, R: Tape Reel (2) AA3: SOT-223, TA3: TO-220, TF3: TO-220F, TF1: TO-220F1, TF2: TO-220F2, TF3T: TO-220F3, TM3: TO-251, TMS: TO-251S, TN3: TO-252, TND: TO-252D (3) L: Lead Free, G: Halogen Free and Lead Free</p>
--	--

MARKING

TO-220 TO-220F TO-220F1 TO-220F2 TO-220F3 TO-251	TO-251S TO-251S2 TO-251S4 TO-252 TO-252-4 TO-252D	SOT-223

■ ABSOLUTE MAXIMUM RATINGS (T_C=25°C, unless otherwise specified)

PARAMETER		SYMBOL	RATINGS	UNIT
Drain-Source Voltage		V _{DSS}	600	V
Gate-Source Voltage		V _{GSS}	±30	V
Avalanche Current (Note 2)		I _{AR}	2.0	A
Drain Current	Continuous	I _D	2.0	A
	Pulsed (Note 2)	I _{DM}	8.0	A
Avalanche Energy	Single Pulsed (Note 3)	E _{AS}	85	mJ
	Repetitive (Note 2)	E _{AR}	4.5	mJ
Peak Diode Recovery dv/dt (Note 4)		dv/dt	4.5	V/ns
Power Dissipation	SOT-223	P _D	1	W
	TO-220		54	W
	TO-220F/TO-220F1 TO-220F3		21	W
	TO-220F2		23	W
	TO-251/TO-251S TO-251S2/TO-251S4 TO-252/TO-252-4 TO-252D		44	W
	Junction Temperature		T _J	+150
Operating Temperature		T _{OPR}	-55 ~ +150	°C
Storage Temperature		T _{STG}	-55 ~ +150	°C

Notes: 1. Absolute maximum ratings are those values beyond which the device could be permanently damaged.

Absolute maximum ratings are stress ratings only and functional device operation is not implied.

2. Repetitive Rating : Pulse width limited by T_J

3. L=42.5mH, I_{AS}=2.0A, V_{DD}=50V, R_G=25 Ω, Starting T_J = 25°C

4. I_{SD}≤2.4A, di/dt≤200A/μs, V_{DD} ≤ BV_{DSS}, Starting T_J = 25°C

■ THERMAL DATA

PARAMETER		SYMBOL	RATINGS	UNIT
Junction to Ambient	SOT-223	θ _{JA}	150	°C/W
	TO-220/TO-220F TO-220F1/TO-220F2 TO-220F3		62.5	°C/W
	TO-251/TO-251S TO-251S2/TO-251S4 TO-252/TO-252-4 TO-252D		100	°C/W
	Junction to Case		θ _{JC}	14
SOT-223	2.32	°C/W		
TO-220	5.95	°C/W		
TO-220F/TO-220F1 TO-220F3	5.43	°C/W		
TO-220F2	2.87	°C/W		
TO-251/TO-251S TO-251S2/TO-251S4 TO-252/TO-252-4 TO-252D		°C/W		

■ ELECTRICAL CHARACTERISTICS (T_C=25°C, unless otherwise specified)

PARAMETER	SYMBOL	TEST CONDITIONS	MIN	TYP	MAX	UNIT
OFF CHARACTERISTICS						
Drain-Source Breakdown Voltage	BV _{DSS}	V _{GS} = 0V, I _D = 250μA	600			V
Drain-Source Leakage Current	I _{DSS}	V _{DS} = 600V, V _{GS} = 0V			10	μA
		V _{DS} = 480V, T _C = 125°C			100	μA
Gate-Source Leakage Current	Forward	I _{GSS}			100	nA
	Reverse					
					-100	nA
Breakdown Voltage Temperature Coefficient	ΔBV _{DSS} /ΔT _J	I _D =250μA, Referenced to 25°C		0.4		V/°C
ON CHARACTERISTICS						
Gate Threshold Voltage	V _{GS(TH)}	V _{DS} = V _{GS} , I _D = 250μA	2.0		4.0	V
Static Drain-Source On-State Resistance	R _{DS(ON)}	V _{GS} = 10V, I _D = 1A		3.9	5.0	Ω
DYNAMIC CHARACTERISTICS						
Input Capacitance	C _{ISS}	V _{DS} = 25V, V _{GS} = 0V, f = 1MHz		210	290	pF
Output Capacitance	C _{OSS}			31	43	pF
Reverse Transfer Capacitance	C _{RSS}			4.5	6	pF
SWITCHING CHARACTERISTICS						
Turn-On Delay Time	t _{D(ON)}	V _{DD} = 30V, I _D = 0.5A, R _G = 25Ω (Note 1, 2)		40	60	ns
Turn-On Rise Time	t _R			30	45	ns
Turn-Off Delay Time	t _{D(OFF)}			52	60	ns
Turn-Off Fall Time	t _F			20	35	ns
Total Gate Charge	Q _G	V _{DS} = 50V, V _{GS} = 1.0V, I _D = 1.3A (Note 1, 2)		11	13	nC
Gate-Source Charge	Q _{GS}			4.4		nC
Gate-Drain Charge	Q _{GD}			1.3		nC
DRAIN-SOURCE DIODE CHARACTERISTICS						
Drain-Source Diode Forward Voltage	V _{SD}	V _{GS} = 0V, I _{SD} = 2.0A			1.4	V
Continuous Drain-Source Current	I _{SD}				2.0	A
Pulsed Drain-Source Current	I _{SM}				8.0	A

Notes: 1. Pulse Test: Pulse width ≤ 300μs, Duty cycle ≤ 2%
 2. Essentially independent of operating temperature

TEST CIRCUITS AND WAVEFORMS



Peak Diode Recovery dv/dt Test Circuit

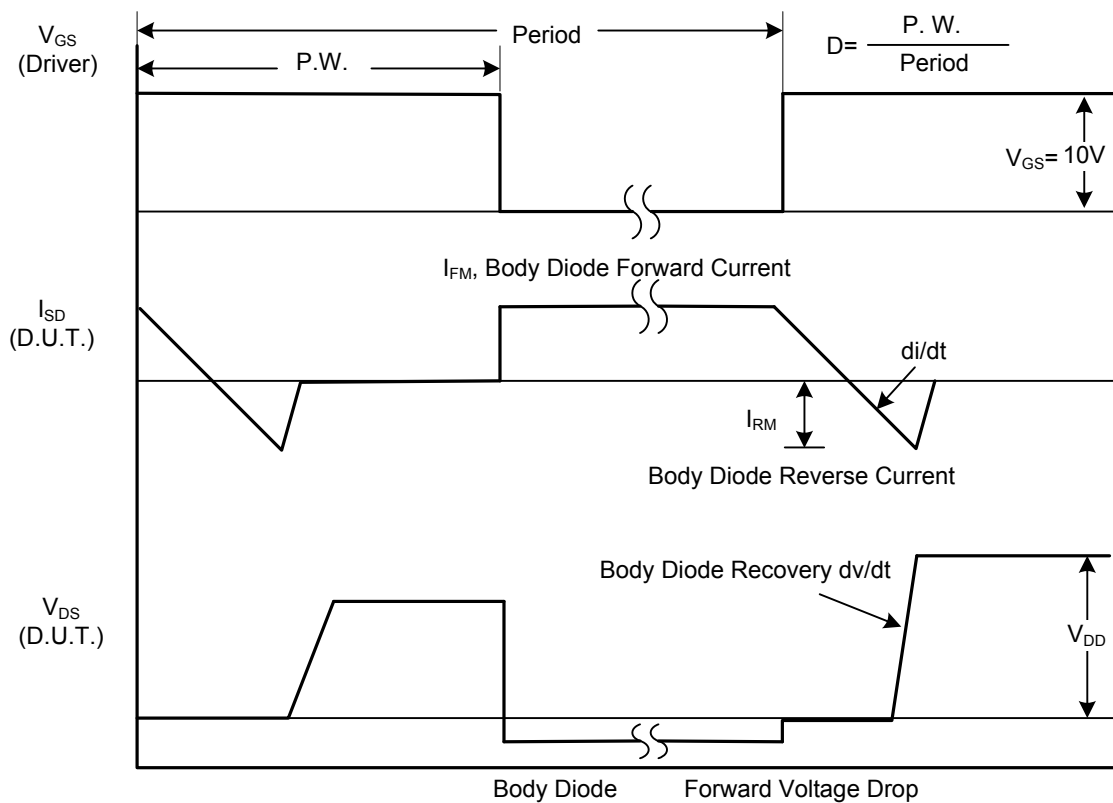

Peak Diode Recovery dv/dt Waveforms

TEST CIRCUITS AND WAVEFORMS (Cont.)

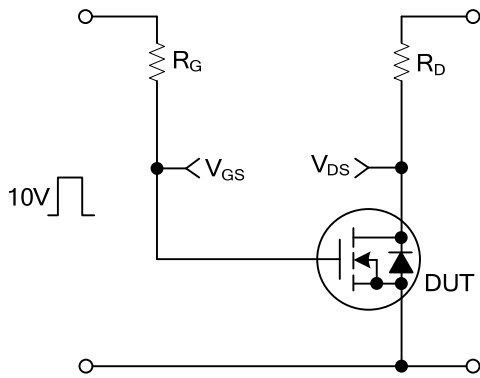

Switching Test Circuit

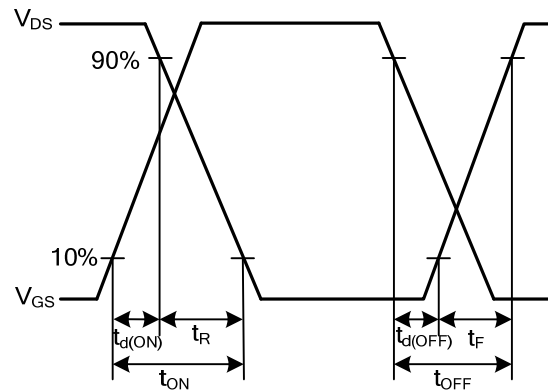

Switching Waveforms

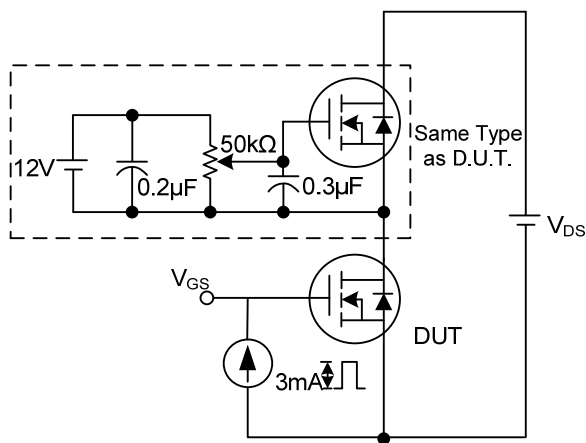

Gate Charge Test Circuit

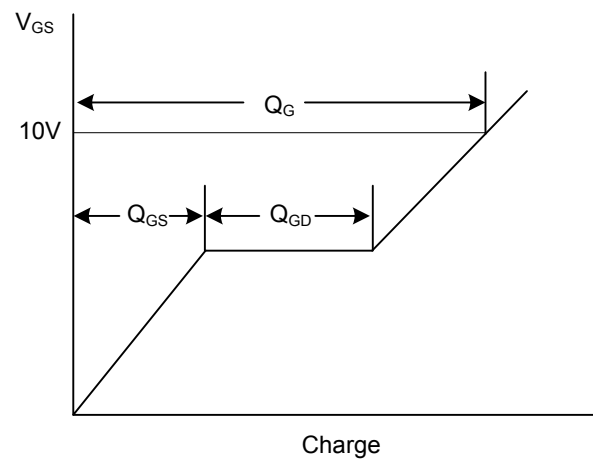

Gate Charge Waveform

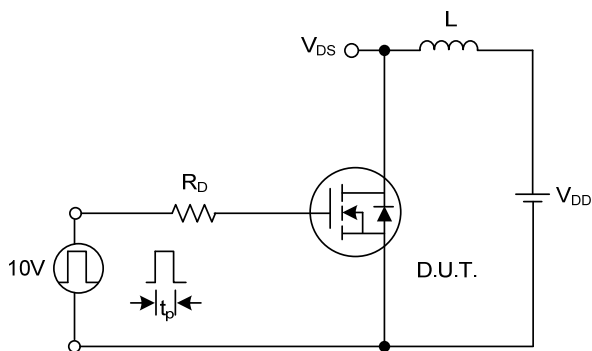

Unclamped Inductive Switching Test Circuit

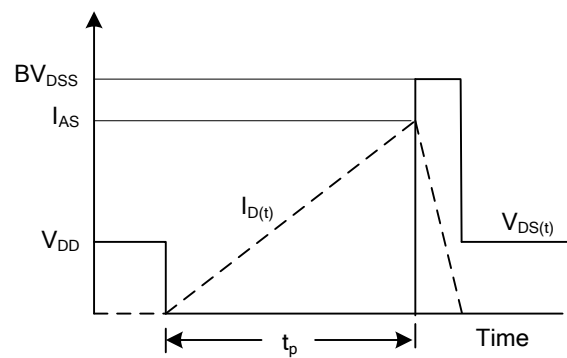

Unclamped Inductive Switching Waveforms

■ TYPICAL CHARACTERISTICS

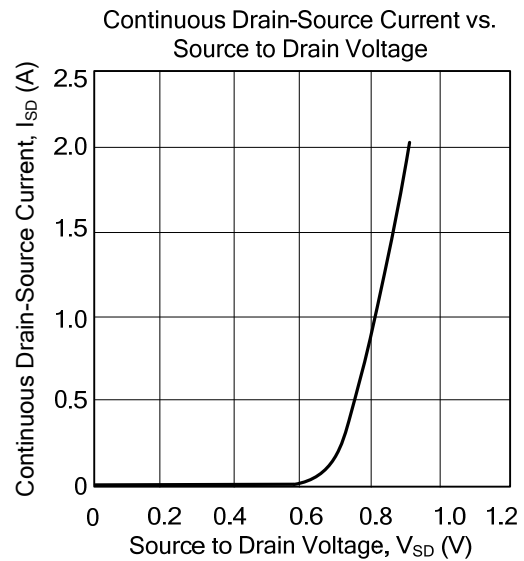
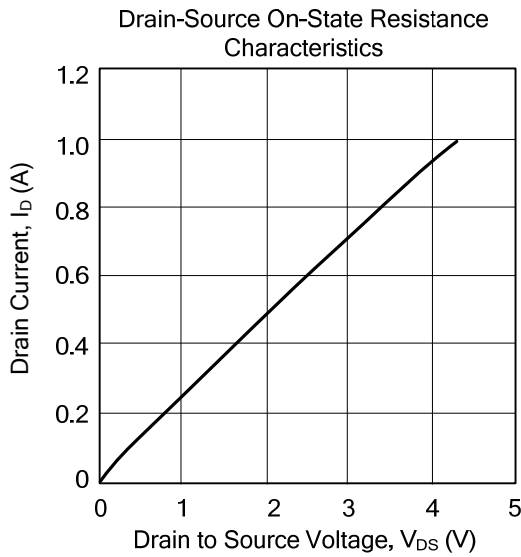
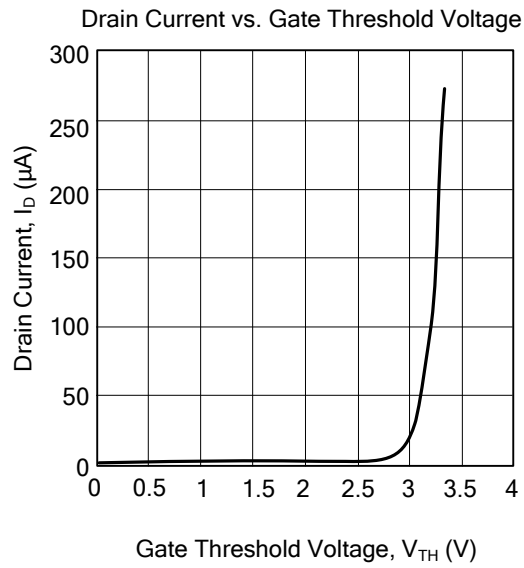
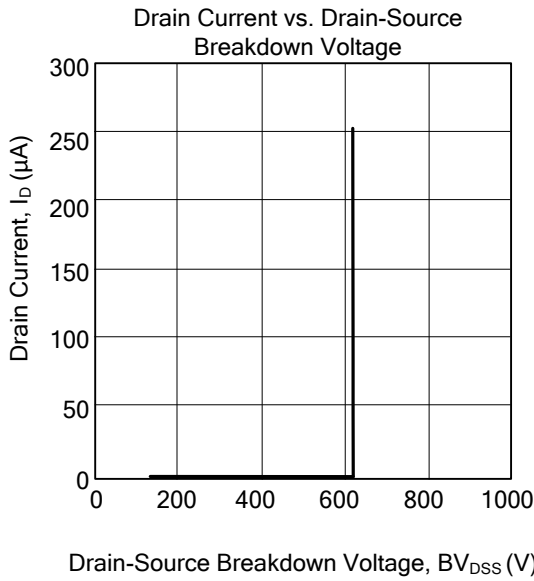

UTC assumes no responsibility for equipment failures that result from using products at values that exceed, even momentarily, rated values (such as maximum ratings, operating condition ranges, or other parameters) listed in products specifications of any and all UTC products described or contained herein. UTC products are not designed for use in life support appliances, devices or systems where malfunction of these products can be reasonably expected to result in personal injury. Reproduction in whole or in part is prohibited without the prior written consent of the copyright owner. The information presented in this document does not form part of any quotation or contract, is believed to be accurate and reliable and may be changed without notice.