

VM149B

Version : A.001
Issue Date : 2010/06/08
File Name : SP-VM149B-A.001.doc
Total Page : 13

*110mA, 10Bit Current Sinking VCM Driver
with I²C Interface*



新竹市科學園區展業一路9號7樓之1

SILICON TOUCH TECHNOLOGY INC.

9-7F-1, Prosperity Road I, Science Based Industrial Park,

Hsin-Chu, Taiwan 300, R.O.C.

Tel : 886-3-5645656 Fax : 886-3-5645626

VM149B

110mA, 10-Bit Current Sinking VCM Driver with I²C Interface

General Specifications

The VM149B is a VCM(Voice Coil Motor) driver IC with I²C interface control that is capable of programmable sinking output current. It has a built-in internal voltage reference and operates with a supply voltage range from 2.4V to 5.5V. The DAC is controlled by a signal transmit through a 2-wire I²C serial interface which operates in an I²C fast mode (400 kHz). The VM149B is designed for applications such as image stabilization, auto-focus, in camera phones, and other portable module devices.

Features and Benefits

- Programmable sinking output current
- I²C serial interface
- DAC with 10-BIT resolution
- 2.4V – 5.5V power source
- Selective Output Slew Rate Control(SRC)
- Low voltage control for digital pin PS, SDA, and SCL(i.e., V_{IH} = 1.4V @ VDD = 2.8V)
- Power saving mode leakage current 2.4uA max.
- Power saving mode
- Automatic power on reset
- Ultra small package: WLCSP (0.78mm*1.27mm*0.35mm)

Ordering Information

Part Number	Package	Marking
VM149B WLCSP	WLCSP, 6Pin	TBD

Terminology

Resolution

The DAC resolution is defined by the power factor of 2, which defines the number of distinct digitized levels.

N-bit resolution $\rightarrow 2^N$ distinct digitized levels

Differential Nonlinearity (DNL) error

The variation in digitized step value away from 1 LSB by any two adjacent digitized levels, gain and offset errors removed.

Integral Nonlinearity (INL)

INL is a deviation of the actual transfer response from a straight line. Usually, INL error is referred to the maximum INL error.

Pin Assignment of WLCSP (0.78mm*1.27mm*0.35mm)

TOP View

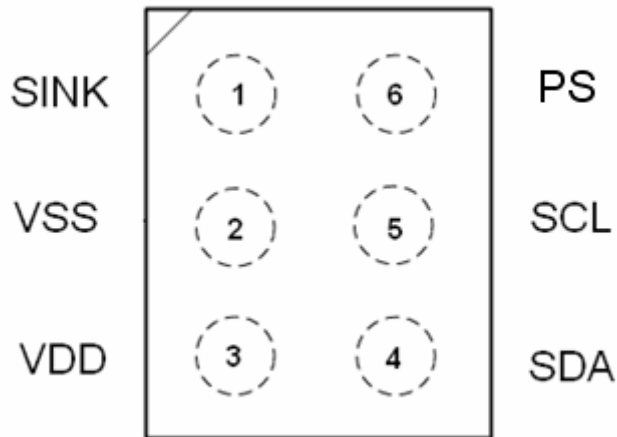

Pin Number	Pin Name	Description
1	SINK	Analog Output : Current Sink Pin
2	VSS	Ground Input Pin
3	VDD	Power Input Pin
4	SDA	I ² C Interface Data Line(Serial Data Line)
5	SCL	I ² C Interface Clock Line(Serial Clock Line)
6	PS	Digital Input: Power saving control (When PS=High, chip is disabled) (When PS=Low, chip is enabled)

Absolute Maximum Ratings

Unless otherwise noted, T_A= 25°C

Characteristic	Symbol	Rating	Unit
Supply Voltage	V _{DD}	-0.4 ~ 5.5	V
Input Signal Voltage	V _{IN}	-0.4 ~ V _{DD} +0.4	V
Maximum Sink Current	I _{SINK}	127	mA
Operating Temperature	T _{OPR}	-40 ~ 85	°C
Storage Temperature	T _{STG}	-55 ~ 150	°C

Electrical Characteristic

Unless otherwise noted, $T_A = 25^\circ\text{C}$, $V_{DD} = 2.8\text{ V}$ and $V_{CM} \approx 18\Omega, 460\mu\text{H}$.

Item	Sym.	Condition	Limit			Unit
			Min.	Typ.	Max.	
Power Supply						
Supply Voltage	V_{DD}		2.4	2.8	5.5	V
Supply Current (I_{DD})	I_{PS}	PS = High (chip is disabled)	-	35	50	μA
	I_{DD0}	PS = Low, SPS(*1)= High	-	0.2	0.4	mA
	I_{DD1}	PS = Low, SPS(*1)= Low	-	1.6	2.3	mA
PS, SDA, SCL digital pin						
Input Voltage High	V_{IH}	-	$0.5 \cdot V_{DD}$	-	$V_{DD} + 0.4$	V
Input Voltage Low	V_{IL}	-	-0.4	-	$0.2 \cdot V_{DD}$	V
Input Current High	I_{IH}				± 1	μA
Input Current Low	I_{IL}				± 1	μA
Parameters						
DAC Resolution			-	10	-	Bits
DNL			-	± 0.7	± 1	LSB
INL			-	± 1.5	± 4	LSB
Maximum Output Sink Current	$I_{S,max}$	D[9:0]=3FF(*2)		102		mA
Zero Code Output Sink Current	$I_{S,min}$	D[9:0]=000(*2)	-	0.1	1	μA
Output Offset Current	I_{OS}	PS = L, SPS(*1)= H	-	0.1	1	μA
Voltage Drop	ΔV	$\Delta V = V_{SINK} - V_{MVSS}$ (*3) (@ $I_{SINK} = 80\text{ mA}$)	-	0.35	0.44	V

Note:

(*1): SPS (Soft Power Saving, 2nd standby mode): IC power saving mode, controlled by software.

(*2): The value of sink current through pin SINK is set by D[9:0] linearly.

(*3): V_{SINK} is the voltage of SINK pin, and V_{MVSS} is the voltage of motor driver VSS pin

Block Diagram

(WLCSP)

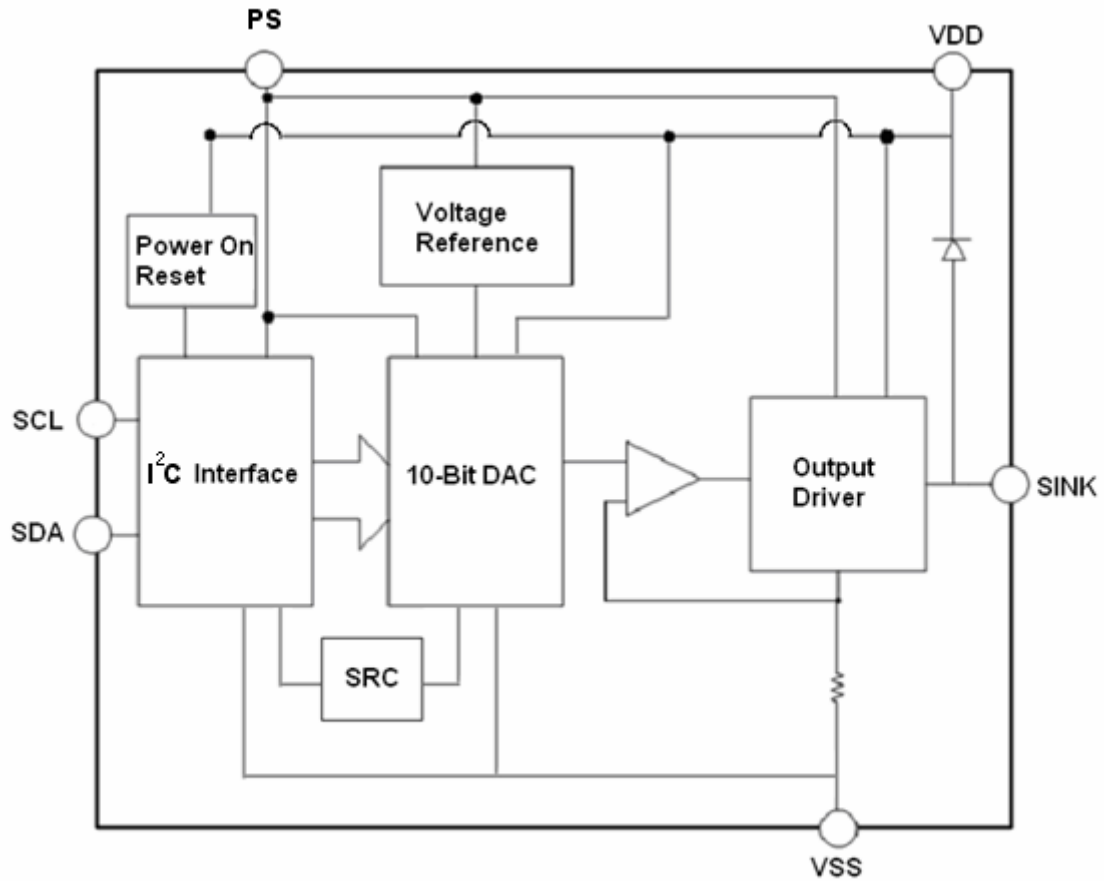

Data Format

VM149B Write Mode

In the writing mode, data is written to the VM149B and shifted into a 16-bit input register. After all 16 bits of data have been shifted in, a STOP signal is generated by master controller. The data in the input register is transferred to the DAC at the same time.

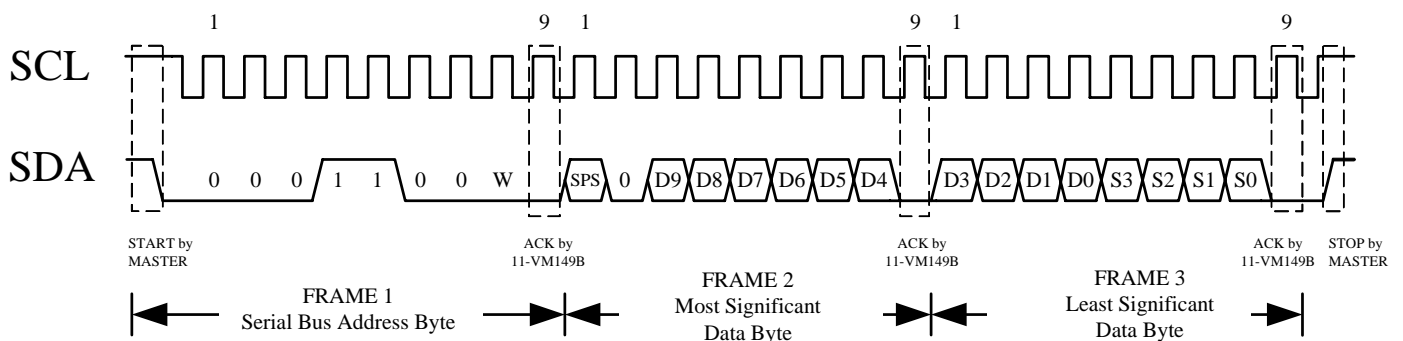

VM149B Read Mode

In reading mode, data is read from IC to a master controller in the same bit order.

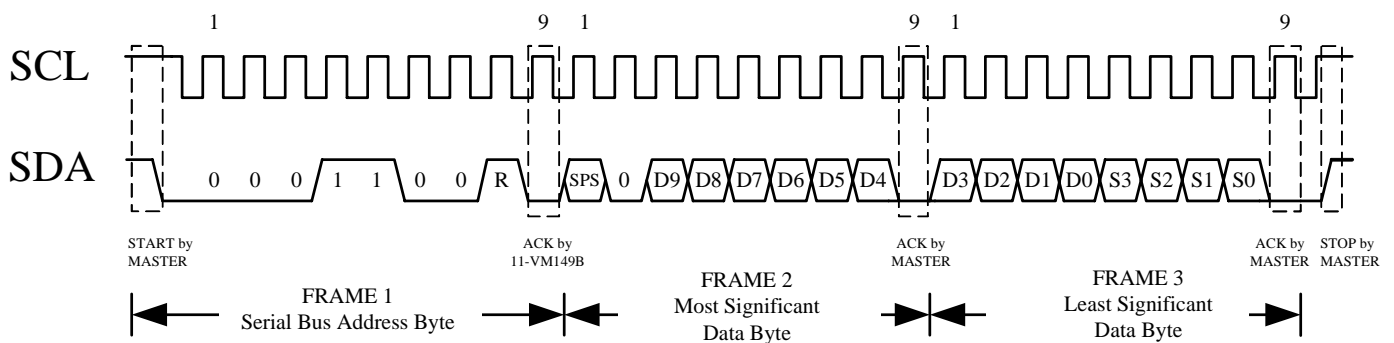

Table

	MSB								LSB							
Serial Data Bits	7	6	5	4	3	2	1	0	7	6	5	4	3	2	1	0
Input Register	R15	R14	R13	R12	R11	R10	R09	R08	R07	R06	R05	R04	R03	R02	R01	R00
Function	SPS	0	D9	D8	D7	D6	D5	D4	D3	D2	D1	D0	S3	S2	S1	S0

- **SPS (Soft Power Saving, 2nd standby mode):** IC power saving, controlled by software.

The operations are defined by the following table.

PS	SPS	IC status
High	-	Power saving
Low	Low	Normal
	High	Soft power saving

If PS is at logic high level; the chip is forced to shut down all power. If PS is at logic low level, the chip will be controlled by the SPS bit(the R15 bit of the register) to perform normally(SPS=Low) or to softly power off the IC(SPS=High). It is recommended to keep PS at high level (PS = H) while the chip is in no operation mode to save power for all applications.

- **D[9:0]:** The level of sink current through pin SINK is set by D[9:0].

- **S[3:0]:** Output Current Slew Rate Control: The output current slew rate can be set by S[3:2] as step control and S[1:0] as step period.

S[3:2] : code step control

S[3:2]	Code per step
0	0 (no SRC)
1	1
2	2
3	4

S[1:0] :SRC step period

S[1:0]	Period (us)
0	64
1	128
2	256
3	512

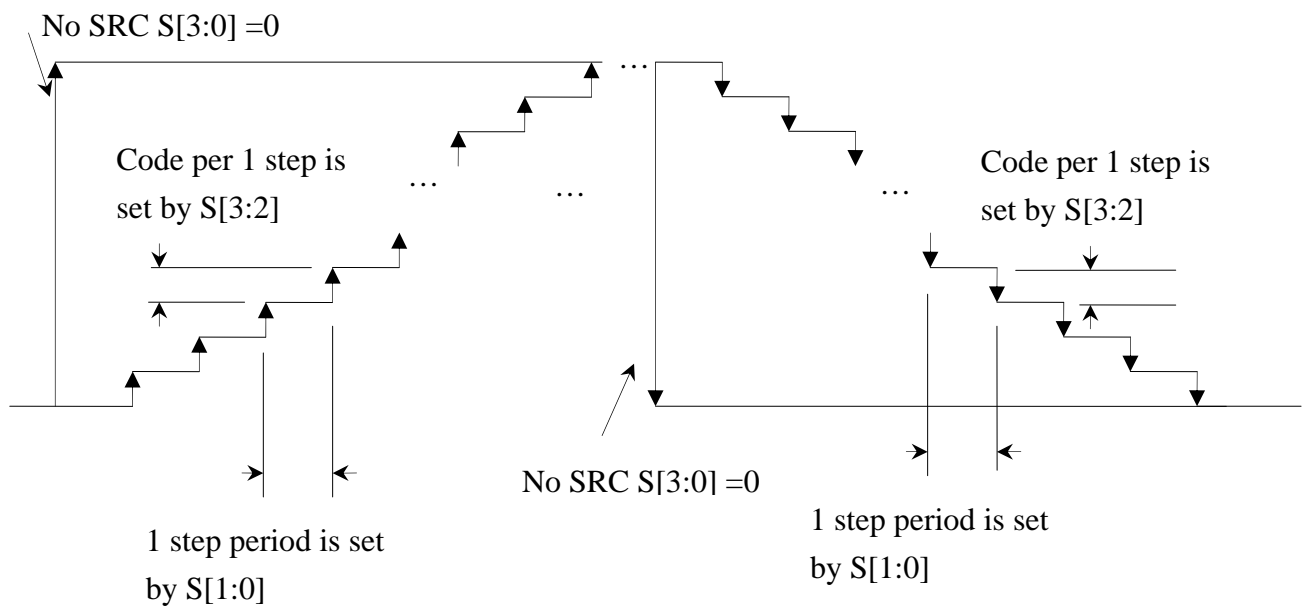

Application Circuit

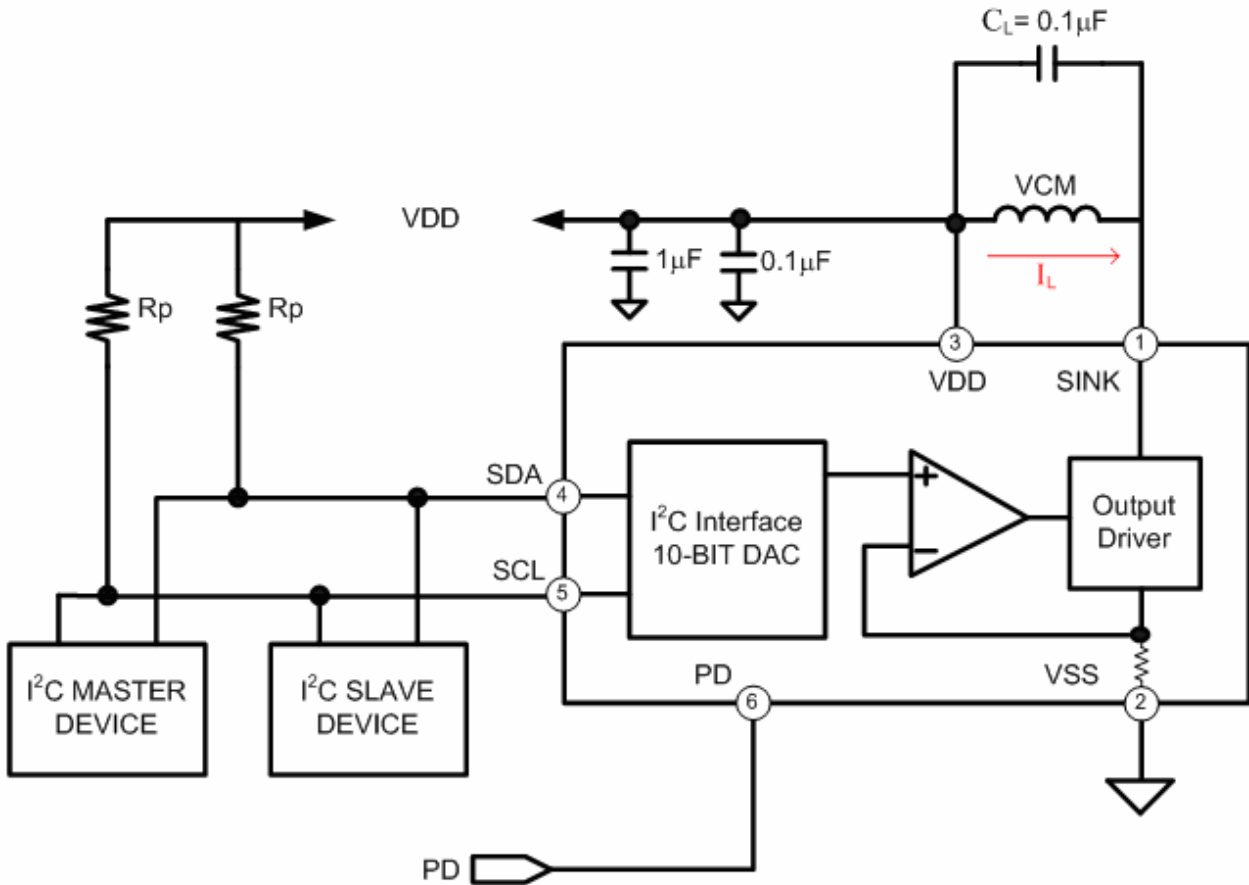

Application Notes

- The VM149B is a constant current driving IC for applications in Auto-Focus. The supply voltage range VDD of VM149B is from 2.4V to 5.5V. The input range of digital control pin PS, and digital I/O pins SCL and SDA, are defined such that logic “High” is from $0.5 \times VDD$ to $VDD + 0.4V$ and logic “Low” is from $-0.4V$ to $0.2 \times VDD$. Therefore, the three digital pins are suitable controlled by 1.8V ISP.
- In order to ensure the stability of output current, a capacitance C_L is suggested to be installed between the two terminals of VCM. The suggested value of C_L is in the range of 0.1~0.22 μ F to match different VCMs.

Package Specifications (WLCSP): (0.78mm*1.27mm*0.35mm)

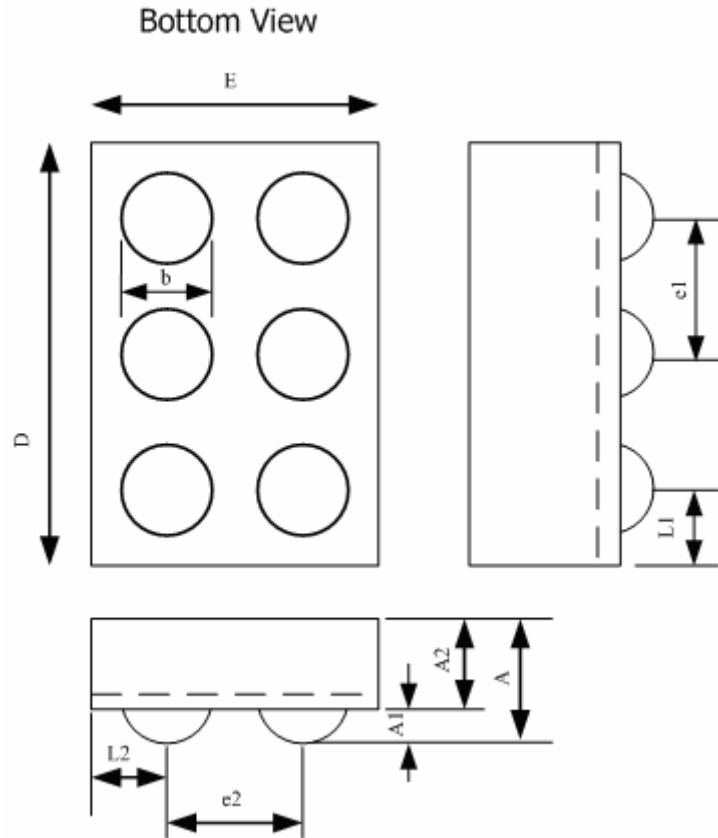

SYMBOL	DIMENSION (mm)		
	MIN.	NOM.	MAX.
A	0.325	0.350	0.375
A1	0.090	0.100	0.110
A2	0.235	0.250	0.265
b	0.234	0.260	0.286
D	1.255	1.270	1.285
E	0.765	0.780	0.795
e1	0.380	0.400	0.420
e2	0.380	0.400	0.420
L1	0.215	0.235	0.255
L2	0.170	0.190	0.210

The products listed herein are designed for ordinary electronic applications, such as electrical appliances, audio-visual equipment, communications devices and so on. Hence, it is advisable that the devices should not be used in medical instruments, surgical implants, aerospace machinery, nuclear power control systems, disaster/crime-prevention equipment and the like. Misusing those products may directly or indirectly endanger human life, or cause injury and property loss.

Silicon Touch Technology, Inc. will not take any responsibilities regarding the misuse of the products mentioned above. Anyone who purchases any products described herein with the above-mentioned intention or with such misused applications should accept full responsibility and indemnify. Silicon Touch Technology, Inc. and its distributors and all their officers and employees shall defend jointly and severally against any and all claims and litigation and all damages, cost and expenses associated with such intention and manipulation.

Silicon Touch Technology, Inc. reserve the right to make changes to their products or to discontinue any product or service without notice, and advise customers to obtain the latest version of relevant information to verify, before placing orders, that information being relied on is current and complete.