

C3225X7R2J473K200AM

TDK Item Description : C3225X7R2J473KT5***



Application & Main Feature

Commercial Grade (Open Mode)

Series

C3225 [EIA CC1210]

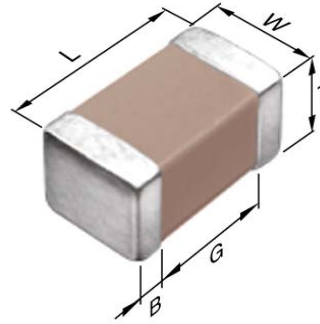

Dimensions

L 3.20mm +/-0.4mm
 W 2.50mm +/-0.3mm
 T 2.00mm +/-0.2mm
 B 0.20mm Min.
 G

Temperature Characteristic

X7R (-55 to 125 degC +/-15%)

Rated Voltage

2J (630Vdc)

Capacitance

47nF

Capacitance Tolerance

K (+/-10%)

Dissipation Factor

3% Max.

Insulation Resistance

10Gohm Min.

AEC-Q200

Not Applicable

|Z|, ESR vs. Freq. Characteristics

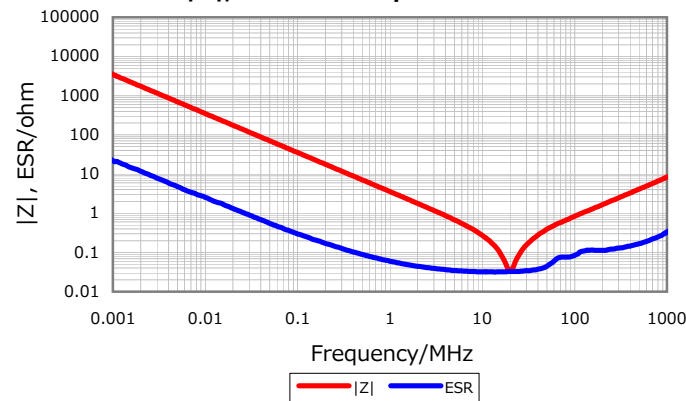

Cap. vs. Freq. Characteristic

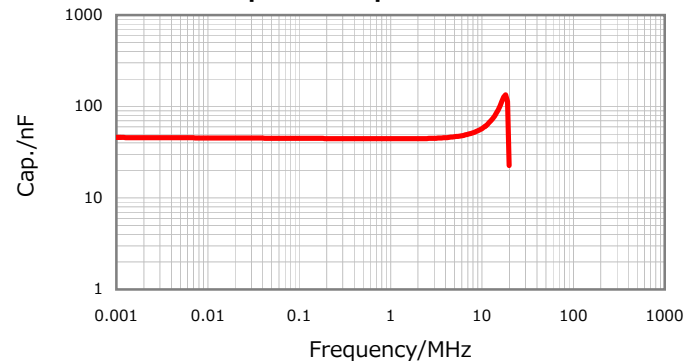

DC Bias Characteristic

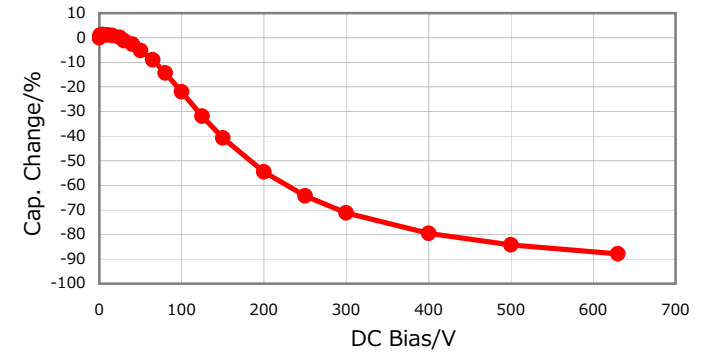

Temperature Characteristics

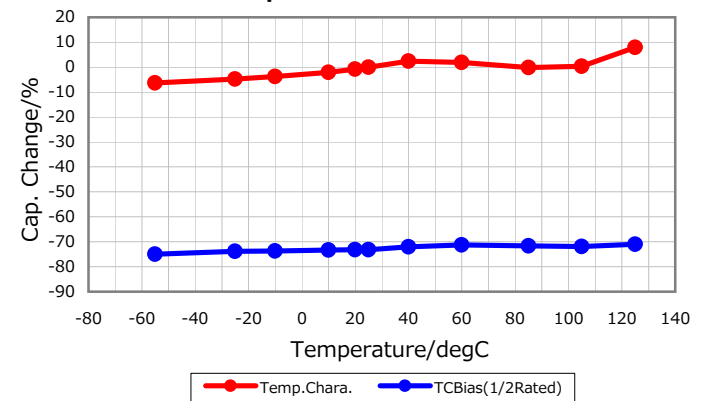

Ripple Temperature Rise Characteristics

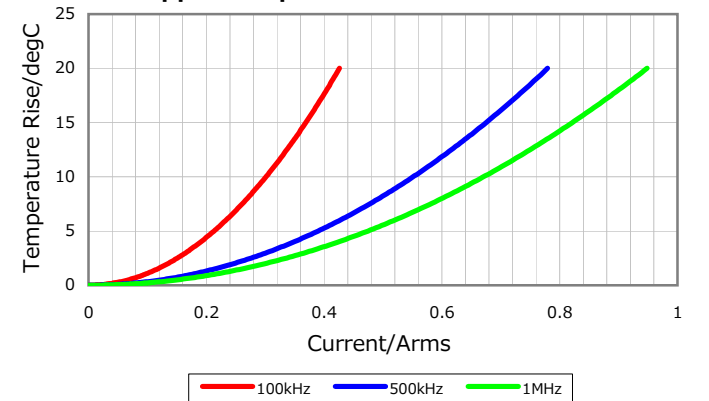

Characterization Sheet (Multilayer Ceramic Chip Capacitors)



All specifications are subject to change without notice.

January 4, 2016