

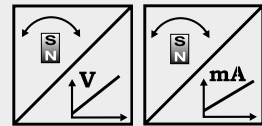

Magnetic Angle Sensor 0 - 360°

- Measurement range 0 - 360°
- Protection class IP67
- Analog output
- Compact, low profile housing
- Non-contact with external position magnet
- Wear free



Specifications	Outputs	Voltage 0.5 ... 10 V Voltage 0.5 ... 4.5 V ratiometric Current 4 ... 20 mA (3 wire)
	Measurement range	0 ... 15° to 0 ... 360° in 15° increments
Resolution	0.03 % (60 ... 360°); 0.1 % (15 ... 45°)	
Repeatability	±0.03 % (60 ... 360°); ±0.1 % (15 ... 45°)	
Linearity	±0.5 % f.s. (typ.)	
Rated distance sensor / magnet	Depending on the position magnet	
Protection class	IP67	
Signal characteristics	CW, CCW (Characteristics see page 4)	
Material	Epoxy glass fiber, thermoplastic	
Mounting	Screws M4	
Connection	Connector TE3, 3-pin	
Shock	EN60068-2-27:2010, 100 g/11 ms, 100 shocks	
Vibration	EN60068-2-6:2008, 20 g 10 Hz-2 kHz, 10 cycles	

Order code

PRAS26 - - - -

Model name

Measurement range 15 ... 360° in 15° increments
15 / 30 / 45 / ... / 345 / 360°

Output (see page 3)
U2B = 0.5 ... 10 V
U6 = 0.5 ... 4.5 V ratiometric
I1B = 4 ... 20 mA (3 wire)

Signal characteristics (see page 4)
CW = Signal increasing CW
CCW = Signal increasing CCW

Connection (see page 3)
TE3 = 3-pin connector, Tyco Electronics, type "SlimSeal"

Order code connector cable see page 7

Order example: PRAS26 - 360 - U6 - CW - TE3

Outline drawing
PRAS26

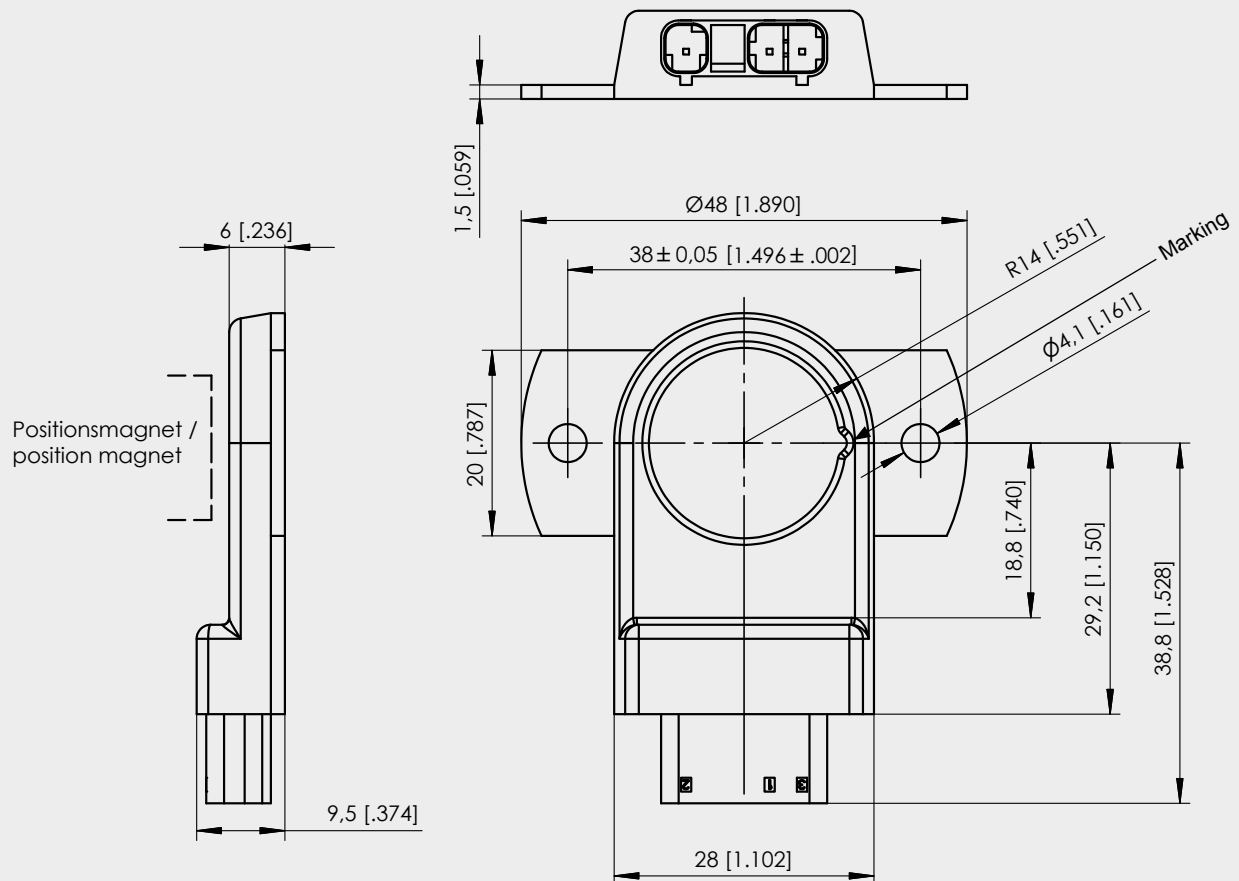

Weight without cable approx. 8 g.
Dimensions informative only.
For guaranteed dimensions please consult factory.

U2B Voltage Output 0.5 ... 10 V 	Excitation voltage	11.5 ... 27 V DC
	Excitation current	12 mA typ., 20 mA max.
	Output voltage	0.5 ... 10 V DC
	Output current	2 mA max.
	Measuring rate	1 kHz standard
	Stability (temperature)	±50 x 10 ⁻⁶ / °C f.s. (typ.) for 90° ...360° ±100 x 10 ⁻⁶ / °C f.s. (typ.) for <90°
	Operating temperature	-20 ... +85 °C
	Protection	Reverse polarity, short circuit
	EMC	EN61326-1:2006
	U6 Voltage Output 10 ... 90 % ratiometr. 	Excitation voltage
Excitation current		8 mA typ., 40 mA max.
Output voltage		10 ... 90 % of the excitation voltage
Output current		2 mA max.
Measuring rate		1 kHz standard
Stability (temperature)		±50 x 10 ⁻⁶ / °C f.s. (typ.) for 90° ...360° ±100 x 10 ⁻⁶ / °C f.s. (typ.) for <90°
Operating temperature		-20 ... +85 °C
Protection		Reverse polarity, short circuit
EMC		EN61326-1:2006
I1B Current Output 4 ... 20 mA (3 wire) 		Excitation voltage
	Excitation current	32 mA typ., 50 mA max.
	Load resistor	200 Ω max.
	Output current	4 ... 20 mA
	Measuring rate	1 kHz standard
	Stability (temperature)	±50 x 10 ⁻⁶ / °C f.s. (typ.) for 90°...360° ±100 x 10 ⁻⁶ / °C f.s. (typ.) for <90°
	Operating temperature	-20 ... +85 °C
	Protection	Reverse polarity, short circuit
	EMC	EN61326-1:2006

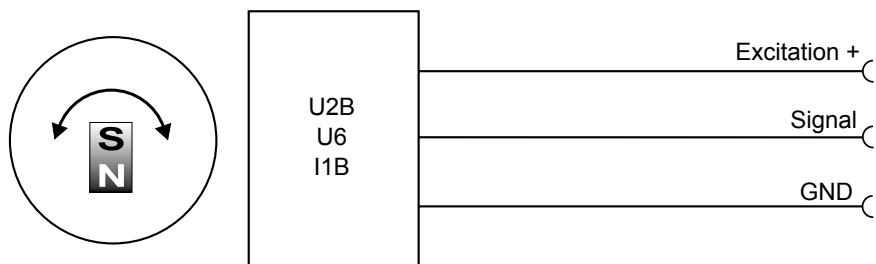

Signal wiring	Signal	Plug connection
	GND	1
	Excitation +	2
	Signal	3

Connection

Mating connector:
 Tyco Electronics,
 SlimSeal, Part-Nr.
 2106135-3, 3-pin

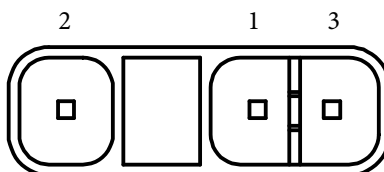

Connector TE3

View to sensor
 connector

Output signal
(CW increasing)

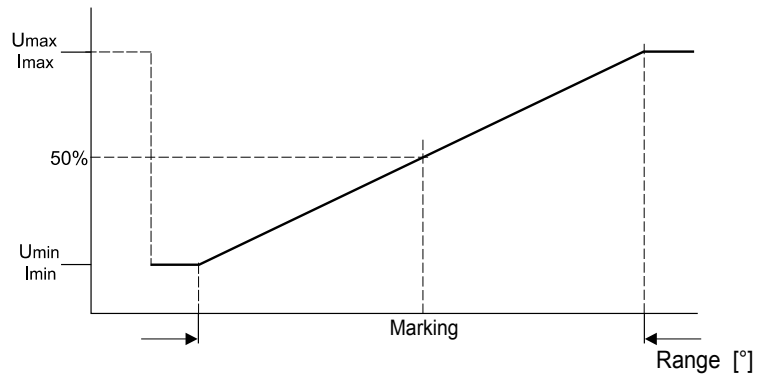

Output signal
(CCW increasing)

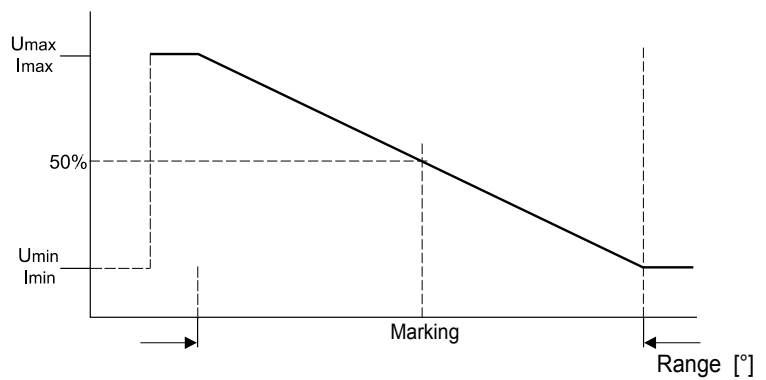

Example angular range 90°

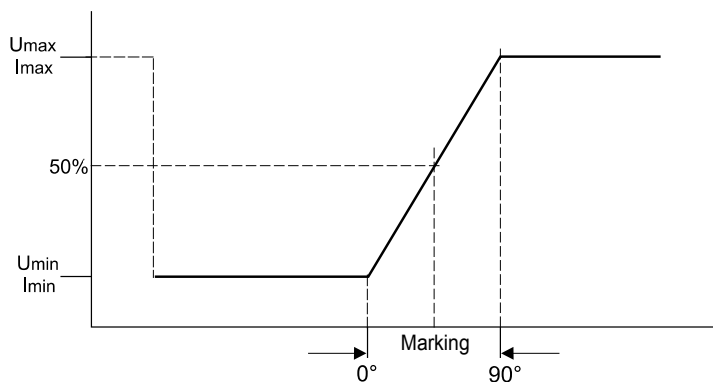

Example angular range 360°

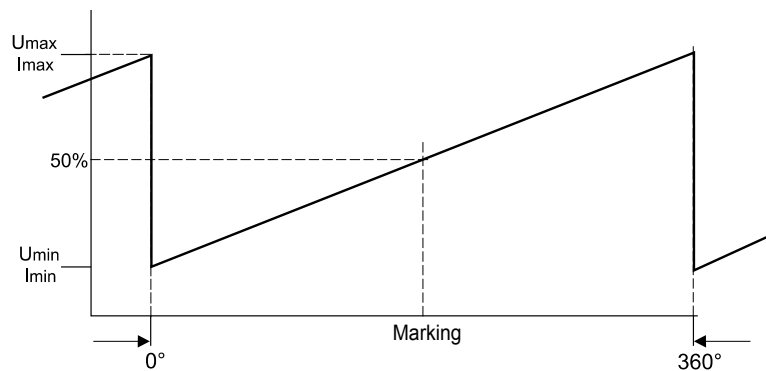

Sensor	Position magnet	Air gap [mm] (a)	Parallelism [°] (b)	Error by axial misalignment [°] (c)					
				0.2 mm	0.5 mm	1 mm	2 mm	3 mm	4 mm
PRAS26	PRMAG20	0 ... 7	0 ... 5	0.1	0.3	0.7	2.0	4.6	–
	PRMAG21	0 ... 2	0 ... 5	0.15	0.3	0.9	3.6	9.6	–
	PRMAG22	0 ... 10	0 ... 5	0.0	0.0	0.7	1.5	3.8	7.0

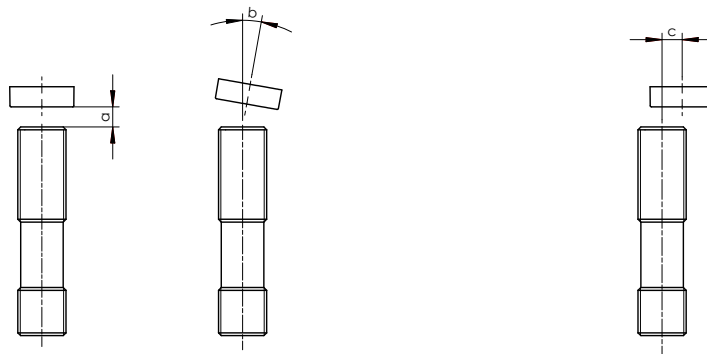

PRMAG20

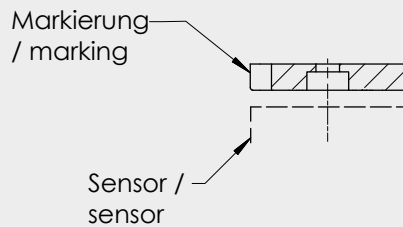
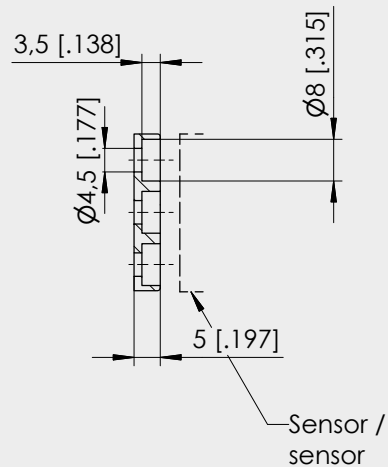
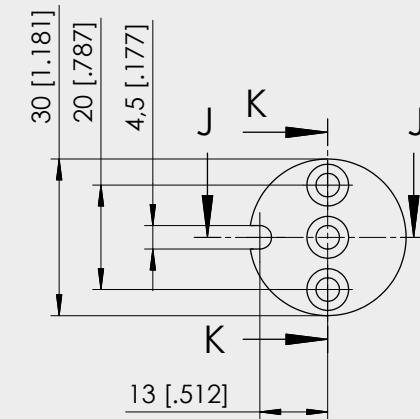

Weight 11 g approx.,
moment of inertia 1.2 kgmm²

A misalignment of the position magnet
has an effect on the linearity

Dimensions in mm [inch]

Dimensions informative only.
For guaranteed dimensions please consult factory.

PRMAG21

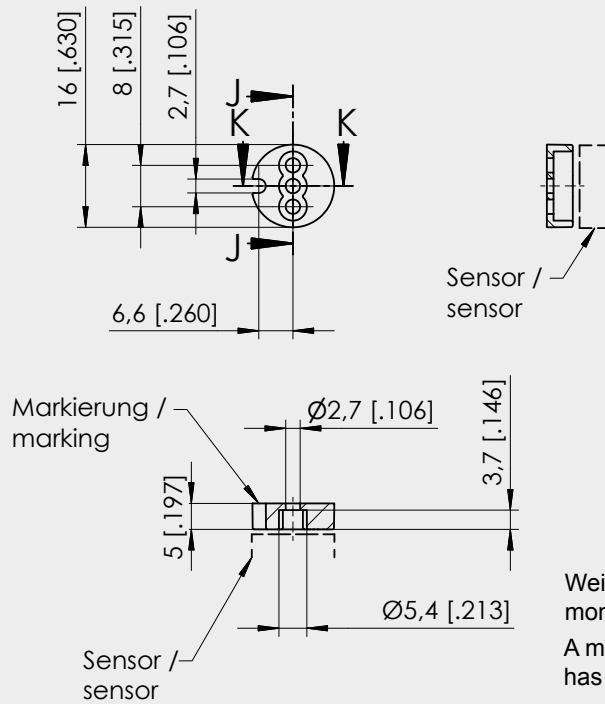

Weight 3 g approx.,
 moment of inertia 0.1 kgmm²
 A misalignment of the position magnet
 has an effect on the linearity

PRMAG22

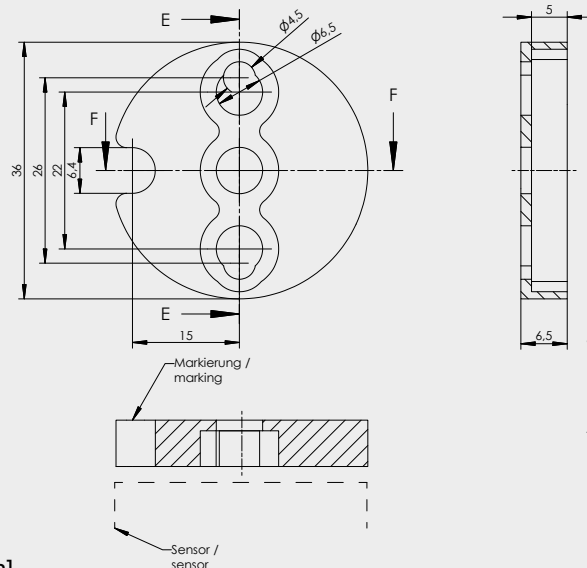

Weight 17 g approx.,
 moment of inertia 3 kgmm²
 A misalignment of the position magnet
 has an effect on the linearity

Dimensions in mm [inch]
 Dimensions informative only.
 For guaranteed dimensions please consult factory.

POSIROT®
PRAS26
Connector



Connector
 3-pin

This cable is supplied with a male 3-pin connector at one end and 3 wires at the other end. Cross section 0.32 mm². Wire length 0.5 m.

Order code:

CONN-TE-3F-G-LITZE-0,5M

Length in m

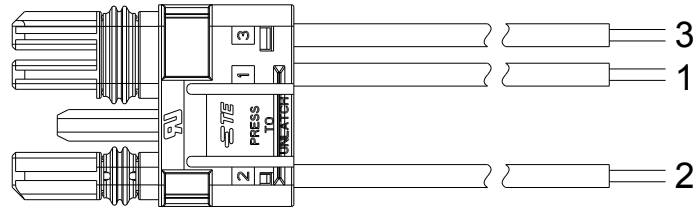

Signal wiring 3-pin connector	Plug connection / Wires		
	1	2	3
blue	brown	white	