

TOP VIEW - SHOW ORIENTATION OF LEGENDS  
IN RESPECT TO THE PCB PIN TERMINALS.

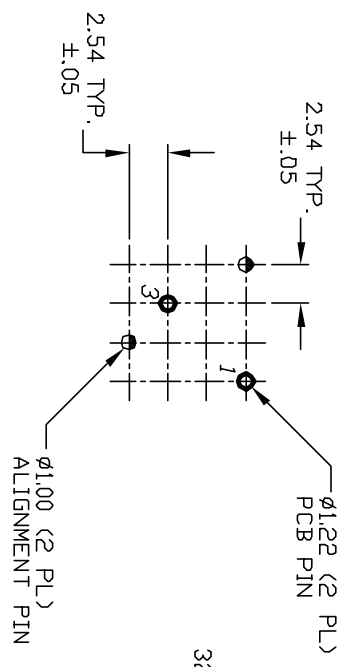

RECOMMENDED P.C.B. LAYOUT

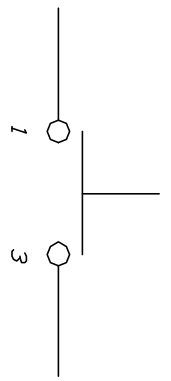
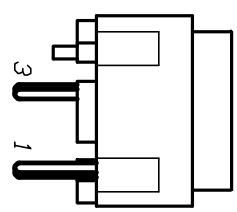
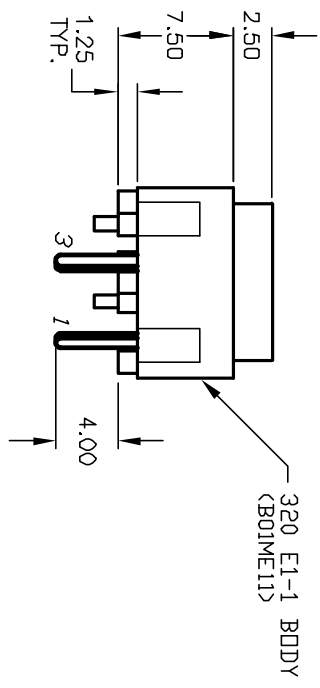
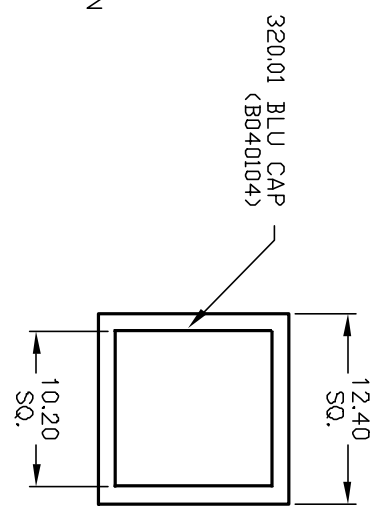

CIRCUIT: SPST  
CONTACT CONFIGURATION

NOTES:

1. ALL DIMENSIONS IN MM
2. GENERAL TOLERANCE: X.X=±0.4  
X.XX=±0.25
3. TERMINAL NO'S FOR REFERENCE ONLY.
4. RATING: 25mA, @50VDC
5. OPERATING FORCE: 120GF
6. TRAVEL TO MAKE: 0.7mm
7. USES CONTACT DOME:  
[B050001] 320E11 CONTACT DOME

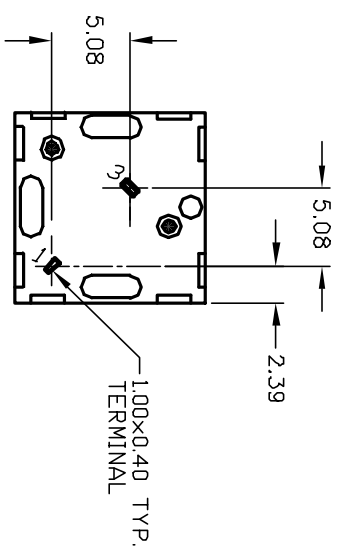

REV.	ECN No.	DESCRIPTION	DATE	CHKD
A	11880	RELEASED FOR PRODUCTION	2/26/03	CJB
THE INFORMATION CONTAINED IN THIS DOCUMENT IS PROPRIETARY TO E-SWITCH AND IS NOT TO BE COPIED OR TRANSMITTED				

TITLE		SCALE		DATE	DR	DWG	REV
320.01 E1-1 BLU		2:1		--	--	XB00484	A
<b>E-SWITCH®</b>							