

ATS177

Single Output Hall Effect Latch

■ Features

- 3.5V to 20V DC operation voltage
- Temperature compensation
- Wide operating voltage range
- Open-Collector pre-driver
- 25mA maximum sinking output current.
- Reverse polarity protection
- Package: SIP3, SOT23

■ Applications

- Brush-less DC Motor
- Brush-less DC Fan
- Revolution counting
- Speed measurement

■ General Descriptions

ATS177 is an integrated Hall effect latched sensor designed for electronic commutation of brush-less DC motor applications. The device includes an on-chip Hall voltage generator for magnetic sensing, a comparator that amplifies the Hall voltage, and a schmitt trigger to provide switching hysteresis for noise rejection, and open-collector output. An internal bandgap regulator is used to provide temperature compensated supply voltage for internal circuits and allows a wide operating supply range.

If a magnetic flux density larger than threshold B_{op} , DO is turned on (low). The output state is held until a magnetic flux density reversal falls below B_{rp} causing DO to be turned off (high).

■ Ordering Information

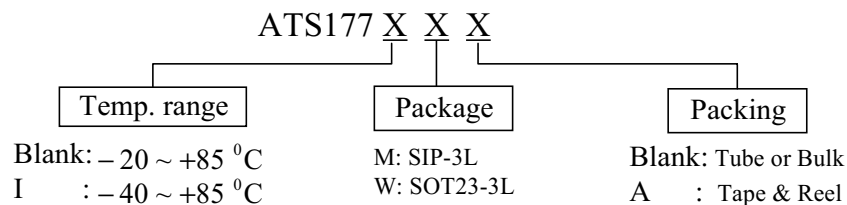

■ Typical Circuit

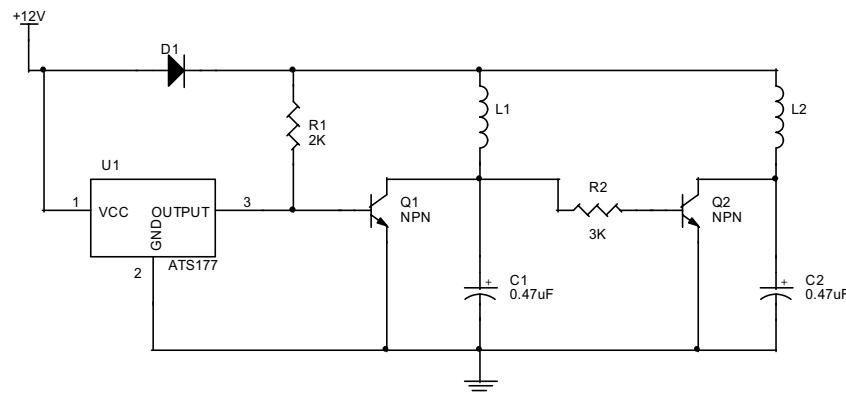

Brush-less DC Fan

This datasheet contains new product information. Analog Technology reserves the rights to modify the product specification without notice. No liability is assumed as a result of the use of this product. No rights under any patent accompany the sale of the product.

ATS177

Single Output Hall Effect Latch



■ Functional Block Diagrams

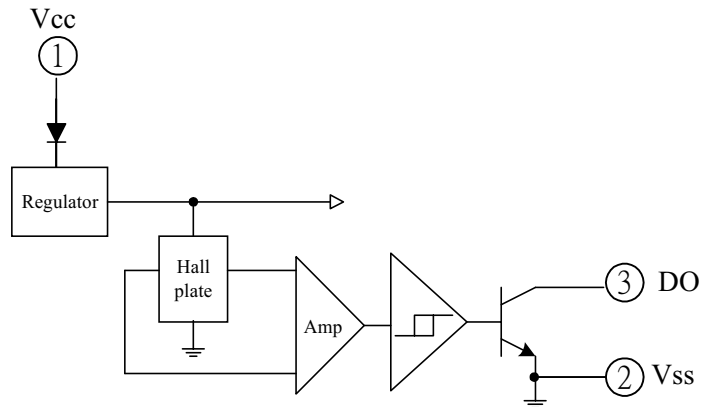

■ Pin Descriptions

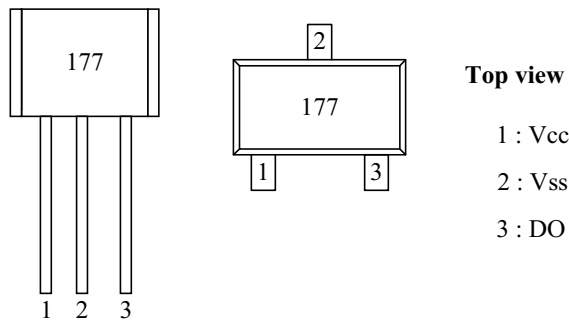

Name	P/I/O	Pin #	Description
Vcc	P	1	Positive power supply
Vss	P	2	Ground
DO	O	3	Digital output

ATS177



Single Output Hall Effect Latch

■ Absolute Maximum Ratings (at Ta= 25°C)

- Supply Voltage, Vcc	20V
- Reverse Vcc Polarity Voltage, V _{RCC}	-20V
- Magnetic flux density, B.....	Unlimited
- Output OFF Voltage, Vce.....	30V
- Output ON Current, Ic	
Continuous.....	25mA
- Operating Temperature Range	
Ta.....	-20°C ~ 85°C
- Storage Temperature Range	
Ts.....	-65°C ~ 150°C
- Package Power Dissipation,	
PD.....	400mW (SIP-3L)
PD.....	200mW(SOT23-3L)
- Maximum Junction Temp.(Tj).....	175°C

■ Electrical Characteristics (Ta=+ 25°C)

Characteristic	Symbol	Test Conditions	Min	Typ	Max	Units
Supply Voltage	Vcc	—	3.5	—	20	V
Output Saturation Voltage	Vce(sat)	Vcc=14V, Ic=20mA	—	300	700	mV
Output Leakage Current	Icex	Vce=14V, Vcc=14V	—	<0.1	10	uA
Supply Current	Icc	Vcc=20V, Output Open	—	5	10	mA
Output Rise Time	tr	Vcc=14V, RL=820Ω, CL=20Pf	—	0.3	1.5	us
Output Falling Time	tf	Vcc=14V, RL=820Ω, CL=20pF	—	0.3	1.5	us

■ Test Circuit

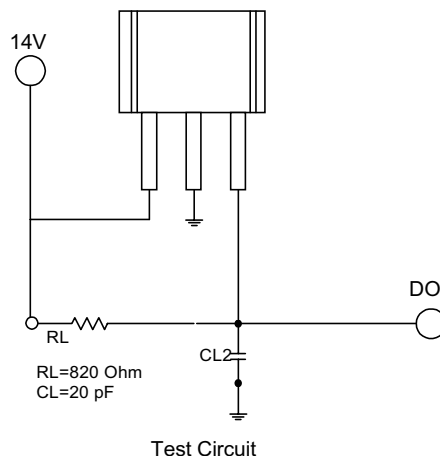

■ **Magnetic Characteristics** ($T_A = 25^\circ\text{C}$, $1\text{mT} = 10\text{ Gauss}$)

Parameter	Symbol	Min	Max	Unit
Operate Point	Bop	—	10	mT
Release Point	Brp	-10	—	mT
Hysteresis	Bhys	5	20	mT

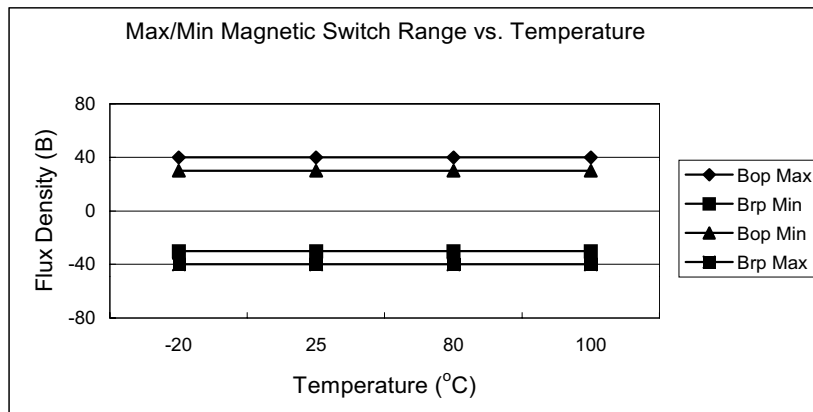
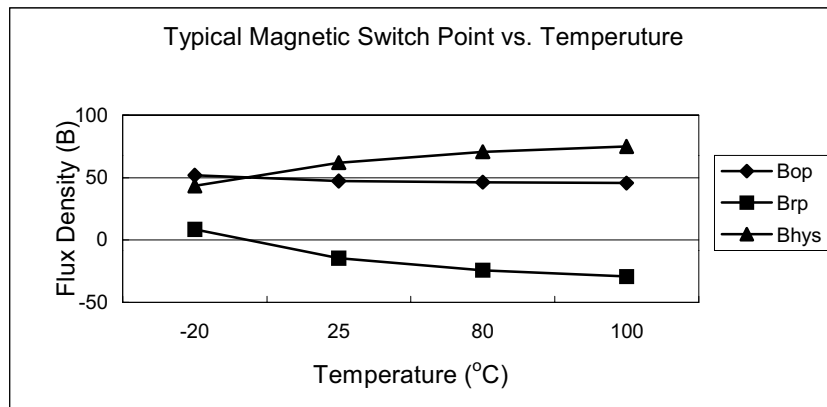
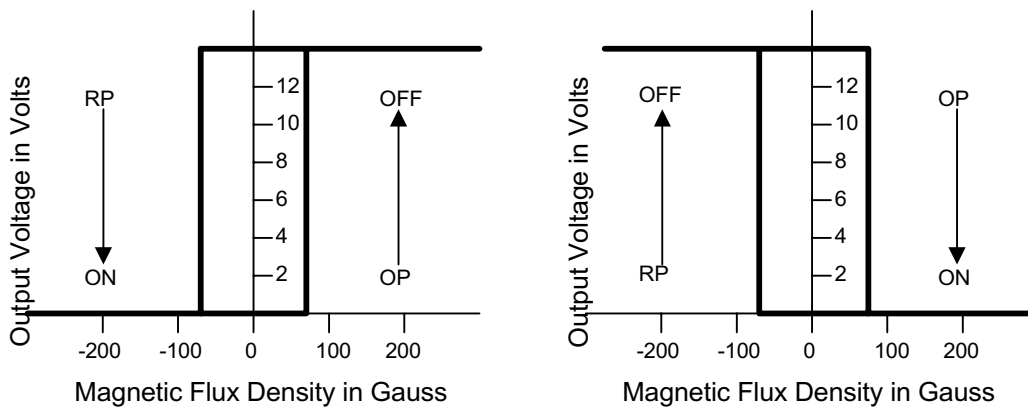

ATS177

Single Output Hall Effect Latch

ATC

■ Marking Information

(1) SOT23-3L

(Top View)

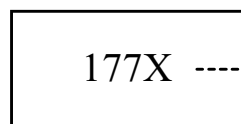

P/N Temp. type

X= Blank: $-20^{\circ}\text{C} \sim +85^{\circ}\text{C}$

X= I : $-40^{\circ}\text{C} \sim +85^{\circ}\text{C}$

(2) SIP-3L

P/N Temp. type

X= Blank: $-20^{\circ}\text{C} \sim +85^{\circ}\text{C}$

X= I : $-40^{\circ}\text{C} \sim +85^{\circ}\text{C}$

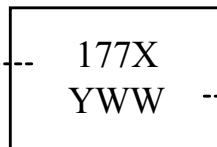

Date code

Y : Year

WW : Nth week

ATS177

Single Output Hall Effect Latch



■ Package Information

(1). SIP-3L

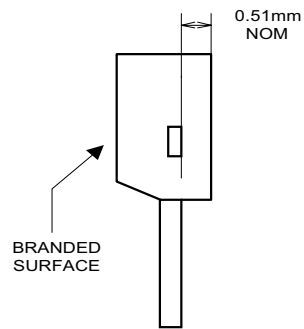

Active Area Depth

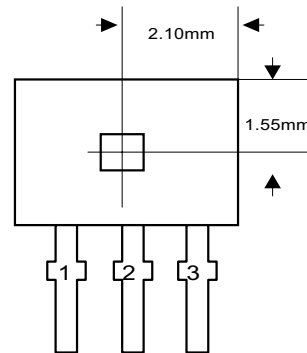

Sensor Location

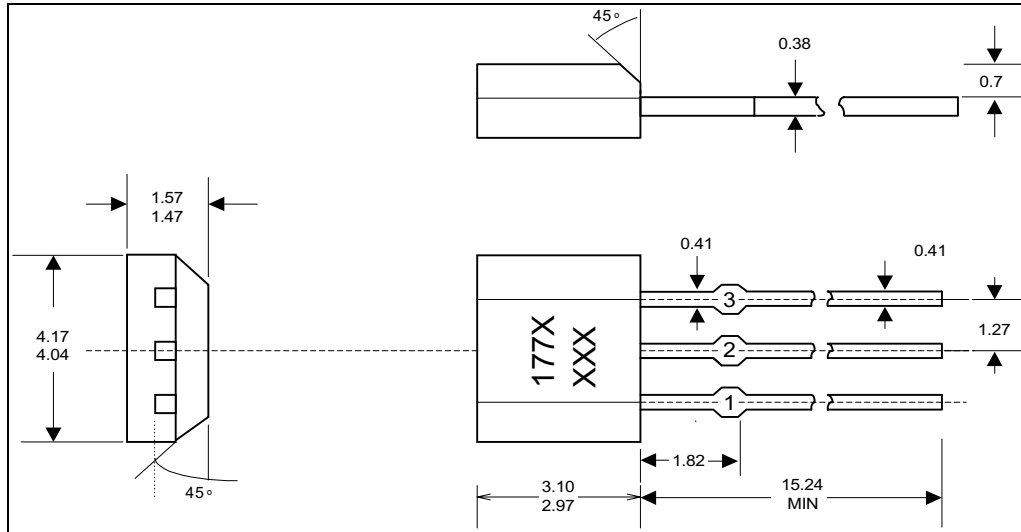

Package Dimension

ATS177

Single Output Hall Effect Latch



(2). SOT23-3L

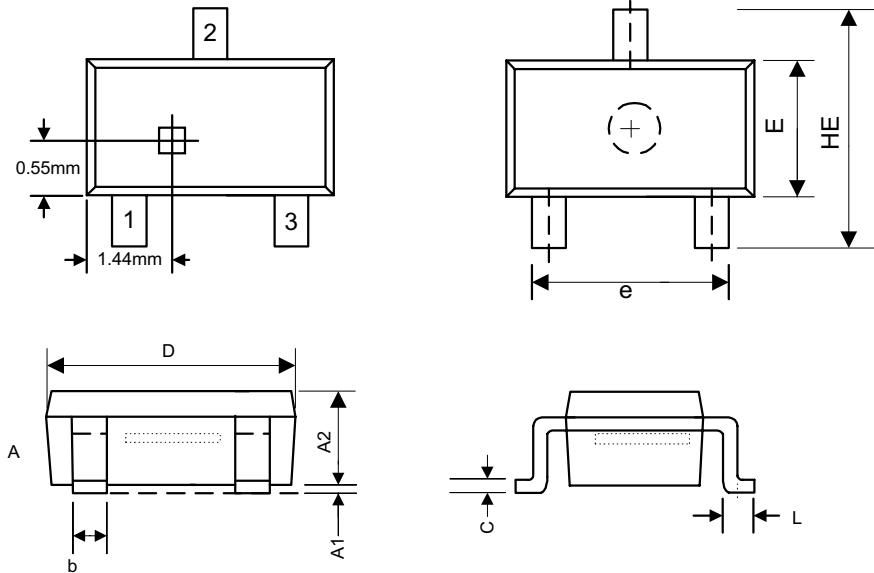

Symbols	Dimensions in millimeters			Dimensions in inches		
	Min	Nom	Max	Min	Nom	Max
A	0.70	0.80	0.90	0.028	0.031	0.035
A1	0.00	—	0.10	0.000	—	0.004
A2	1.00	1.15	1.30	0.039	0.045	0.051
b	0.35	—	0.50	0.014	—	0.020
C	0.10	0.175	0.25	0.004	0.007	0.010
D	2.70	2.90	3.10	0.106	0.114	0.122
E	1.40	1.60	1.80	0.055	0.063	0.071
e	1.70	1.90	2.10	0.067	0.075	0.083
HE	2.80	2.90	3.00	0.110	0.114	0.118
L	0.35	0.45	0.55	0.014	0.018	0.022

Package Dimension