



# High-Frequency Center Probe Test Socket with Adj. Pressure Pad for Devices up to 27mm Sq

## FEATURES

- Aries unique universal socketing system allows the socket to be easily configured for any package, on any pitch (or multiple pitch) from 0.2mm or greater, in any configuration, with little or no tooling charge or extra lead-time.
- For Test & Burn-In of CSP,  $\mu$ BGA, Bump-Array, QFN, QFP, MLF, DFN, SSOP, TSSOP, TSOP, SOP, SOIC, LGA, LCC, PLCC, TO and any SMT package style made. Also can be compatible with PGA packaged devices.
- Quick and easy **Probe Replacement System**: the complete set of probes can be removed and a new set (interposer) can be inserted quickly and easily. The old set can be returned to the factory for repair and sent back within one day.
- Pressure mounting, no soldering required.
- 4-point crown (other styles also available) insures scrub on solder oxides.
- Signal path during test only 0.077 [1.96].
- Accommodates any package up to 27mm square.
- Small overall socket size/profile allows max. number of sockets per BIB and BIB's per oven, while being operator-friendly
- Adjustable pressure pad, with a large tolerance, allows for varying device heights as well as for fine-tuning pressure pad force to meet specific device requirements.



## ORDERING INFORMATION

Consult Factory

**CLEANING, HANDLING, MOUNTING & PROBE REPLACEMENT INFO**

## GENERAL SPECIFICATIONS

- MOLDED SOCKET COMPONENTS: UL 94V-0 PEEK and/or Ultem
- PIN INDUCTANCE: 0.51nH (large probe)
- CONTACT RESISTANCE: <40 m $\Omega$
- 1dB BANDWIDTH: to 10.1GHz (0.80mm pitch) (large probe)
- ESTIMATED CONTACT LIFE: 500,000 cycles
- COMPRESSION SPRING PROBES: heat-treated BeCu with 30 $\mu$  [0.75 $\mu$ ] min. Au per MIL-G-45204 over 30 $\mu$  [0.75 $\mu$ ] min. Ni per SAE AMS-QQ-N-290
- CONTACT FORCE : 6g per contact on 0.20-0.29mm pitch  
: 15g per contact on 0.30-0.35mm pitch  
: 16g per contact on 0.40-0.45mm pitch  
: 25g per contact on 0.50-0.75mm pitch  
: 25g per contact on 0.80mm pitch or larger
- OPERATING TEMPERATURE: -55 $^{\circ}$ C [-67 $^{\circ}$ F] min. to 150 $^{\circ}$ C [302 $^{\circ}$ F] max.
- ALL HARDWARE: Stainless Steel

## MOUNTING CONSIDERATIONS

- SOCKET: mounted with four #4-40 screws (to be removed at time of socket mounted to PCB) or a tapped, insulated backing plate to be used on underside of PCB for high pin count applications
- NOTE: Sockets must be handled with care when mounting or removing sockets to/from PCB
- TEST PCB MINIMUM DIAMETER "G" : 0.025 [0.64] (large probe 0.80mm pitch and larger)  
: 0.015 [0.38] (small probe 0.50-0.75mm pitch)  
: 0.012 [0.31] (small probe 0.40-0.45mm pitch)  
: 0.009 [0.23] (small probe 0.30-0.35mm pitch)  
: 0.004 [0.10] (small probe 0.20-0.20mm pitch)
- TEST PCB DIAMETER SPRING PROBE PAD PLATING: 30 $\mu$  [0.75 $\mu$ ] min. Au per MIL-G-45204 over 30 $\mu$  [0.75 $\mu$ ] min. Ni per SEA AMS-QQ-N-290. Pad must be the same height as top surface of PCB. Please refer to the Custom Socket Drawing supplied by Aries after receipt of your order for your specific application.

A detailed device drawing must be sent to Aries to quote and design a socket.

See Data Sheet for...

### CSP Sockets

- [23016](#) Hybrid Socket
- [23021](#)  $\mu$ BGA up to 6.5mm
- [23017](#)  $\mu$ BGA up to 13mm
- [23018](#)  $\mu$ BGA up to 27mm
- [23018-APP](#) w/Adj Pressure Pad
- [23019](#)  $\mu$ BGA up to 40mm
- [23020](#)  $\mu$ BGA up to 55mm
- [23023](#) Optical Failure Analysis

### RF Sockets

- [24013](#) RF up to 6.5mm
- [24008](#) RF up to 13mm
- [24009](#) RF up to 27mm
- [24011](#) RF up to 40mm
- [24012](#) RF up to 55mm
- [24010](#) RF Machined Socket
- [23022](#) Kelvin Test Socket



Bristol, PA 19007-6810 USA  
TEL (215) 781-9956 • FAX (215) 781-9845  
[WWW.ARIESELEC.COM](http://WWW.ARIESELEC.COM) • [INFO@ARIESELEC.COM](mailto:INFO@ARIESELEC.COM)



**24009-APP**  
1 of 2  
Rev. 1.5



# High-Frequency Center Probe Test Socket with Adj. Pressure Pad for Devices up to 27mm Sq

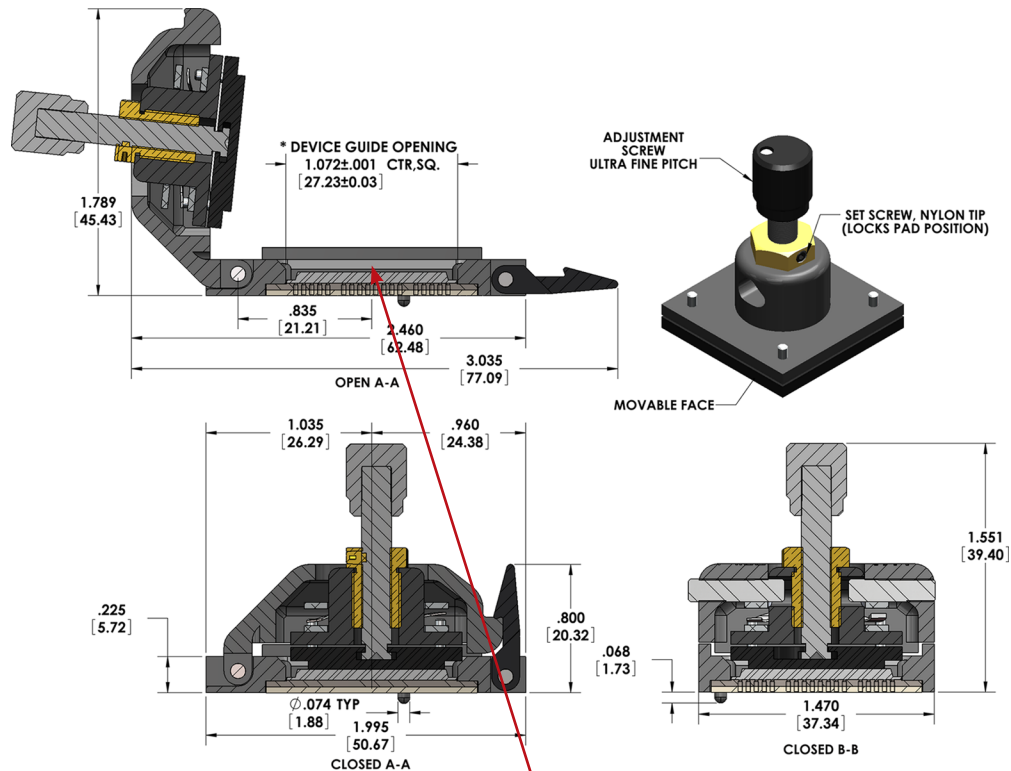

- \* MARKED DIMENSIONS & ITEMS ARE DEVICE DEPENDENT FOR EACH ORDER
- FOR BASE SOCKET INFO PLEASE REFER TO THE 23018 & 24009 DATA SHEETS
- ADJUSTABLE PRESSURE PAD CAN BE CUSTOMIZED FOR SPECIFIC DEVICE HEIGHT RANGE AND FORCE.
- SOCKET SHOWN IS ONLY AN EXAMPLE, EACH ORDER IS DESIGNED FOR THE CUSTOMER'S DEVICE.
- CURRENTLY, THE ADJUSTABLE PRESSURE PAD IS AVAILABLE ONLY FOR DEVICES UP TO 27.15MM SQ. IN SOCKET TYPE 23018 & 24009.
- OTHER SOCKET SIZES WITH THE ADJUSTABLE PRESSURE PAD ARE IN DEVELOPMENT, DESIGN IS PROPRIETARY TO ARIES ELECTRONICS.

**FULL-ARRAY SHOWN AS AN EXAMPLE; YOUR SPECIFIC DEVICE PATTERN/FOOTPRINT WILL BE SUPPLIED WHEN ORDERED.**

PATENT NO. 6844749

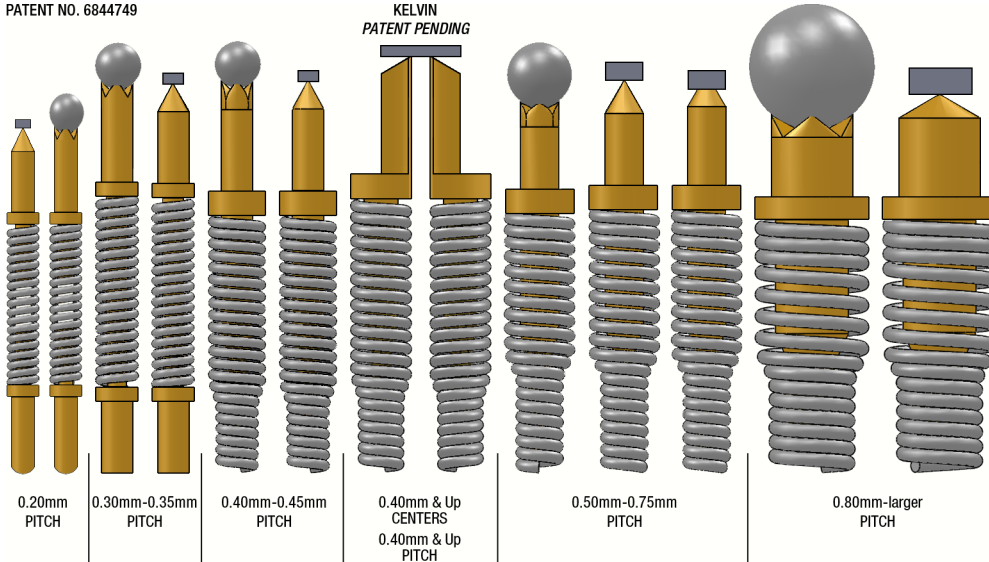

## SPRING PROBES

ALL DIMENSIONS: INCHES [MILLI-METERS]

ALL TOLERANCES: ±0.005 [0.13]  
UNLESS OTHERWISE SPECIFIED

**CUSTOMIZATION:** In addition to the standard products shown on this page, Aries specializes in custom design and production. Special materials, platings, sizes, and configurations can be furnished, depending on the quantity. NOTE: Aries reserves the right to change product general specifications without notice.



Bristol, PA 19007-6810 USA  
TEL (215) 781-9956 • FAX (215) 781-9845  
WWW.ARIESELEC.COM • INFO@ARIESELEC.COM



24009-APP  
2 of 2  
Rev. 1.5