



U74HC244

CMOS IC

OCTAL BUFFER AND LINE DRIVER WITH 3-STATE OUTPUT

DESCRIPTION

The **U74HC244** are octal buffer and line drivers with non-inverting 3-state outputs. When \overline{nOE} is High, the outputs nQ will be in the high impedance.

FEATURES

- * Operation voltage range: 2~6V
- * 3-state output
- * Output Drive Capability: 15 LSTTL Loads

ORDERING INFORMATION

Ordering Number		Package	Packing
Lead Free	Halogen Free		
U74HC244L-D20-T	U74HC244G-D20-T	DIP-20	Tube
U74HC244L-S20-R	U74HC244G-S20-R	SOP-20	Tape Reel
U74HC244L-S20-T	U74HC244G-S20-T	SOP-20	Tube
U74HC244L-P20-R	U74HC244G-P20-R	TSSOP-20	Tape Reel
U74HC244L-P20-T	U74HC244G-P20-T	TSSOP-20	Tube

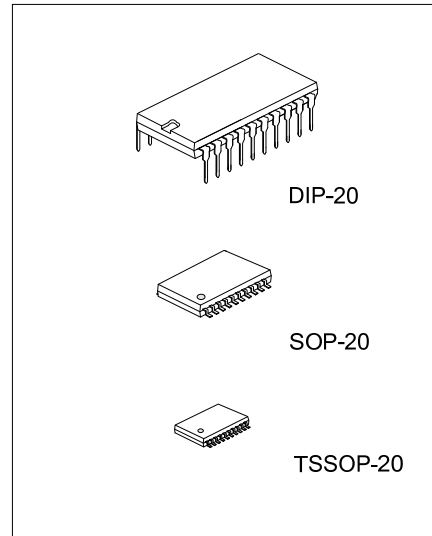

U74HC244L-P20-T	(1)Packing Type (2)Package Type (3)Lead Plating	(1) R: Tape Reel, T: Tube (2) P20: TSSOP-20, S20: SOP-20, D20: DIP-20 (3) G: Halogen Free, L: Lead Free
-----------------	---	---

PIN CONFIGURATION

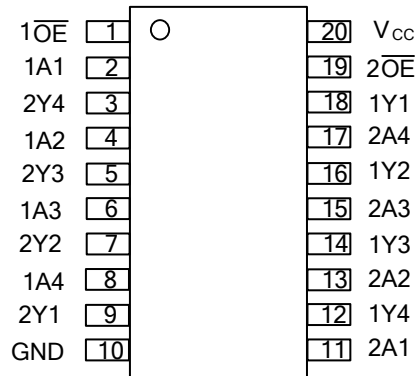

FUNCTION TABLE (each gate)

INPUT(nOE)	INPUT(nAn)	OUTPUT(nYn)
H	X	Z
L	H	H
L	L	L

LOGIC DIAGRAM (positive logic)

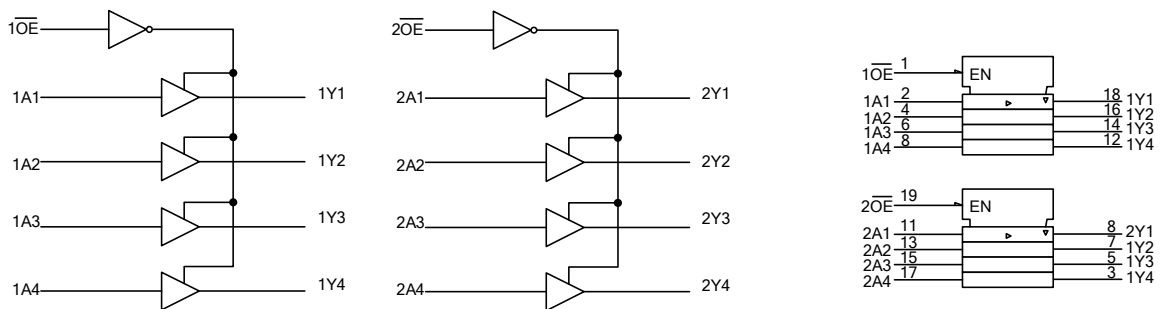

IEC logic symbol

■ ABSOLUTE MAXIMUM RATINGS (unless otherwise specified)

PARAMETER	SYMBOL	RATINGS	UNIT
Supply Voltage	V_{CC}	-0.5~7	V
Input Clamp Current	I_{IK}	± 20	mA
Output Clamp Current	I_{OK}	± 20	mA
Output Current	I_{OUT}	± 35	mA
V_{CC} or GND Current	I_{CC}	± 70	mA
Storage Temperature	T_{STG}	-65 ~ +150	$^{\circ}C$

Note: Absolute maximum ratings are those values beyond which the device could be permanently damaged.
 Absolute maximum ratings are stress ratings only and functional device operation is not implied.

■ RECOMMENDED OPERATING CONDITIONS

PARAMETER	SYMBOL	CONDITIONS	MIN	TYP	MAX	UNIT
Supply Voltage	V_{CC}		2		6	V
Input Voltage	V_{IN}		0		V_{CC}	V
Output Voltage	V_{OUT}		0		V_{CC}	V
Input Rise or Fall Times	t_R, t_F	$V_{CC}=2V$			1000	ns
		$V_{CC}=4.5V$			500	ns
		$V_{CC}=6V$			400	ns
Operating Temperature	T_A		-40		85	$^{\circ}C$

■ STATIC CHARACTERISTICS ($T_A=25^{\circ}C$, unless otherwise specified)

PARAMETER	SYMBOL	TEST CONDITIONS	MIN	TYP	MAX	UNIT
High-Level Input Voltage	V_{IH}	$V_{CC}=2V$	1.5			V
		$V_{CC}=4.5V$	3.15			V
		$V_{CC}=6V$	4.2			V
Low-Level Input Voltage	V_{IL}	$V_{CC}=2V$			0.5	V
		$V_{CC}=4.5V$			1.35	V
		$V_{CC}=6V$			1.8	V
High-Level Output Voltage	V_{OH}	$V_{CC}=2V, I_{OH}=-20\mu A$	1.9	1.998		V
		$V_{CC}=4.5V, I_{OH}=-20\mu A$	4.4	4.499		V
		$V_{CC}=6V, I_{OH}=-20\mu A$	5.9	5.999		V
		$V_{CC}=4.5V, I_{OH}=-6mA$	3.98	4.3		V
		$V_{CC}=6V, I_{OH}=-7.8mA$	5.48	5.8		V
Low-Level Output Voltage	V_{OL}	$V_{CC}=2V, I_{OL}=20\mu A$		0.002	0.1	V
		$V_{CC}=4.5V, I_{OL}=20\mu A$		0.001	0.1	V
		$V_{CC}=6V, I_{OL}=20\mu A$		0.001	0.1	V
		$V_{CC}=4.5V, I_{OL}=6mA$		0.17	0.26	V
		$V_{CC}=6V, I_{OL}=7.8mA$		0.15	0.26	V
Input Leakage Current	$I_{I(LEAK)}$	$V_{CC}=6V, V_{IN}=V_{CC}$ or 0			± 100	nA
Output OFF-State Current	I_{OZ}	$V_{CC}=6V, V_{OUT}=V_{CC}$ or 0, $V_{IN}=V_{IH}$ or V_{IL}			± 0.5	μA
Quiescent Supply Current	I_Q	$V_{CC}=6V, V_{IN}=V_{CC}$ or 0, $I_{OUT}=0$			8	μA
Input Capacitance	C_{IN}	$V_{CC}=2V\sim 6V$		3	10	pF

■ DYNAMIC CHARACTERISTICS (T_A=25°C, Input: t_R, t_F=6ns)

PARAMETER	SYMBOL	TEST CONDITIONS	MIN	TYP	MAX	UNIT
Propagation delay from input (A) to output(Y)	t _{PLH} /t _{PHL}	V _{CC} =2V, C _L =50pF		40	115	ns
		V _{CC} =2V, C _L =150pF		56	165	ns
		V _{CC} =4.5V, C _L =50pF		13	23	ns
		V _{CC} =4.5V, C _L =150pF		18	33	ns
		V _{CC} =6V, C _L =50pF		11	20	ns
		V _{CC} =6V, C _L =150pF		15	28	ns
3-state output enable time n \overline{OE} to nYn	t _{PZH} /t _{PZL}	V _{CC} =2V, C _L =50pF		75	150	ns
		V _{CC} =2V, C _L =150pF		100	200	ns
		V _{CC} =4.5V, C _L =50pF		15	30	ns
		V _{CC} =4.5V, C _L =150pF		20	40	ns
		V _{CC} =6V, C _L =50pF		13	26	ns
		V _{CC} =6V, C _L =150pF		17	34	ns
3-state output disable time n \overline{OE} to nYn	t _{PHZ} /t _{PLZ}	V _{CC} =2V, C _L =50pF		75	150	ns
		V _{CC} =4.5V, C _L =50pF		15	30	ns
		V _{CC} =6V, C _L =50pF		13	26	ns

■ OPERATING CHARACTERISTICS

PARAMETER	SYMBOL	TEST CONDITIONS	MIN	TYP	MAX	UNIT
Power Dissipation Capacitance	C _{pd}	No load		35		pF

■ TEST CIRCUIT AND WAVEFORMS

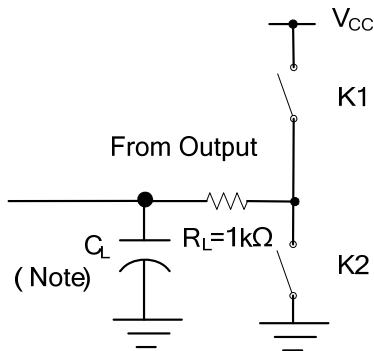

TEST	K1	K2
t_{PLH}/t_{PHL}	Open	Open
t_{PHZ}/t_{PZH}	Open	Close
t_{PLZ}/t_{PZL}	Close	Open

Note: C_L includes probe and jig capacitance.

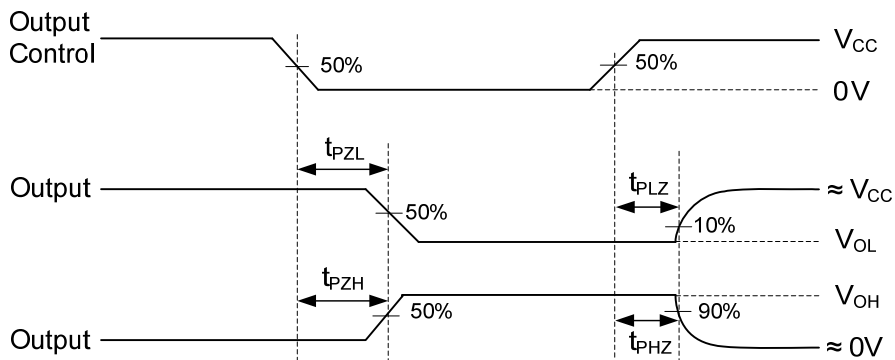
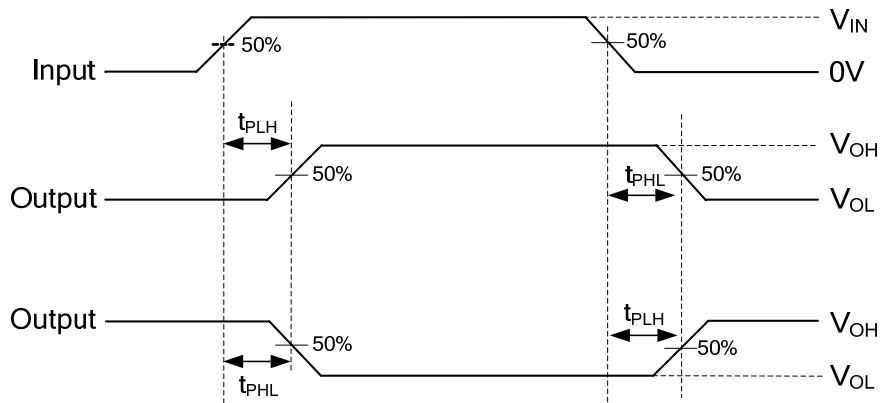

UTC assumes no responsibility for equipment failures that result from using products at values that exceed, even momentarily, rated values (such as maximum ratings, operating condition ranges, or other parameters) listed in products specifications of any and all UTC products described or contained herein. UTC products are not designed for use in life support appliances, devices or systems where malfunction of these products can be reasonably expected to result in personal injury. Reproduction in whole or in part is prohibited without the prior written consent of the copyright owner. The information presented in this document does not form part of any quotation or contract, is believed to be accurate and reliable and may be changed without notice.