

# BM77SPPx3MC2

## Bluetooth® 4.0 Dual Mode Module

### Features:

- Complete, Fully Certified, Embedded 2.4 GHz Bluetooth® Version 4.0 Module
- Bluetooth Classic (BR/EDR) and Low Energy (LE)
- Bluetooth SIG Certified
- Onboard embedded Bluetooth Stack
- Transparent UART mode for seamless serial data over UART interface
- Easy to configure with Windows GUI or direct by MCU
- Firmware can be field upgradable via UART
- Compact surface mount module: 22 x 12 x 2.4 mm
- Castellated surface mount pads for easy and reliable host PCB mounting
- Environmentally friendly, RoHS compliant
- Perfect for Portable Battery Operated Devices
- Internal Battery Regulator Circuitry
- Worldwide regulatory certifications

### Operational:

- Single operating voltage: 3.2V to 4.3V
- Temperature range: -20 to 70°C
- Simple, UART interface
- Integrated crystal, internal voltage regulator, and matching circuitry
- Multiple I/O pins for control and status

### RF/Analog:

- Frequency: 2.402 to 2.480 GHz
- Receive Sensitivity: -90 dBm (Classic); -92 dBm (LE)
- Power Output: 2 dBm (typ.)

### Data Throughput:

- 50 kilobyte (Classic on Android)
- 8 kilobyte (LE on iOS7)

### MAC/Baseband/Higher Layer:

- Secure AES128 encryption
- GAP, SDP, SPP, GATT profiles

### Antenna:

- Ceramic Chip Antenna (BM77SPPS3MC2)
- External Antenna Connection via RF Pad (BM77SPP03MC2)

### Compliance:

- Bluetooth SIG QDID: B021961
- Modular Certified for the United States (FCC) and Canada (IC)
- European R&TTE Directive Assessed Radio Module
- Australia, New Zealand, Korea, Taiwan, Japan

FIGURE 1:



### General Description:

The BM77 is a fully-certified Bluetooth® Version 4.0 (BR/EDR/LE) module for designers who want to easily add dual mode Bluetooth® wireless capability to their products. Delivering local connectivity for the Internet of Things (IoT), the BM77 bridges your product to Smart Phones and Tablets for convenient data transfer, control and access to cloud applications.

This Bluetooth SIG certified module provides a complete wireless solution with Bluetooth stack onboard, integrated antenna, and worldwide radio certifications in a compact surface mount package, 22 x 12 x 2.4 mm. It supports GAP, SDP, SPP, and GATT profiles. Data is transferred over the Bluetooth link by sending/receiving data via transparent UART mode, making it easy to integrate with any processor or Microcontroller with a UART interface. Configuration is made easy using a Windows® based GUI or directly via UART by a MCU.

### Applications:

- Mobile Point of Sales (mPOS)
- LED lighting
- Wearables
- Digital Sports
- Fitness Devices
- Health Care/ Medical
- Automotive Accessories
- Home Automation
- Remote Control Toys

## 1.0 DEVICE OVERVIEW

The BM77 is a complete, fully certified, embedded 2.4 GHz Bluetooth® version 4.0 (BR/EDR/LE) wireless module. It incorporates an on-board Bluetooth stack, cryptographic accelerator, power management subsystem, 2.4 GHz transceiver, and RF power amplifier (see Figure 1-1). With the BM77, designers can embed Bluetooth functionality rapidly into virtually any device.

The BM77 provides cost and time-to-market savings as a self-contained module solution. The module has been designed to provide integrators with a simple Bluetooth solution that features:

- Ease of integration and programming
- Vastly reduced development time
- Minimum system cost
- Interoperability with Bluetooth hosts
- Maximum value in a range of applications

The BM77 can independently maintain a low-power wireless connection. Low-power usage and flexible power management maximize the module's lifetime in battery-operated devices.

The BM77 module comes in two varieties. The BM77SPPS3MC2 is a complete, fully regulatory certified module with integral ceramic chip antenna and shield. The BM77SPP03MC2 is a lower cost alternative with external antenna and no shield. The integrator is responsible for the antenna, antenna matching, and regulatory certifications.

The BM77 is a small, compact, surface mount module with castellated pads for easy and reliable host PCB mounting. The module is compatible with standard pick-and-place equipment.

**TABLE 1-1: BM77 MODULE FAMILY TYPES**

Device	Antenna	Shield	Regulatory Certifications
BM77SPPS3MC2-0007AA	Integral ceramic chip	Yes	FCC, IC, CE, KCC, NCC, Japan
BM77SPP03MC2-0007AA	External	No	CE

**FIGURE 1-1: BM77 BLOCK DIAGRAM**

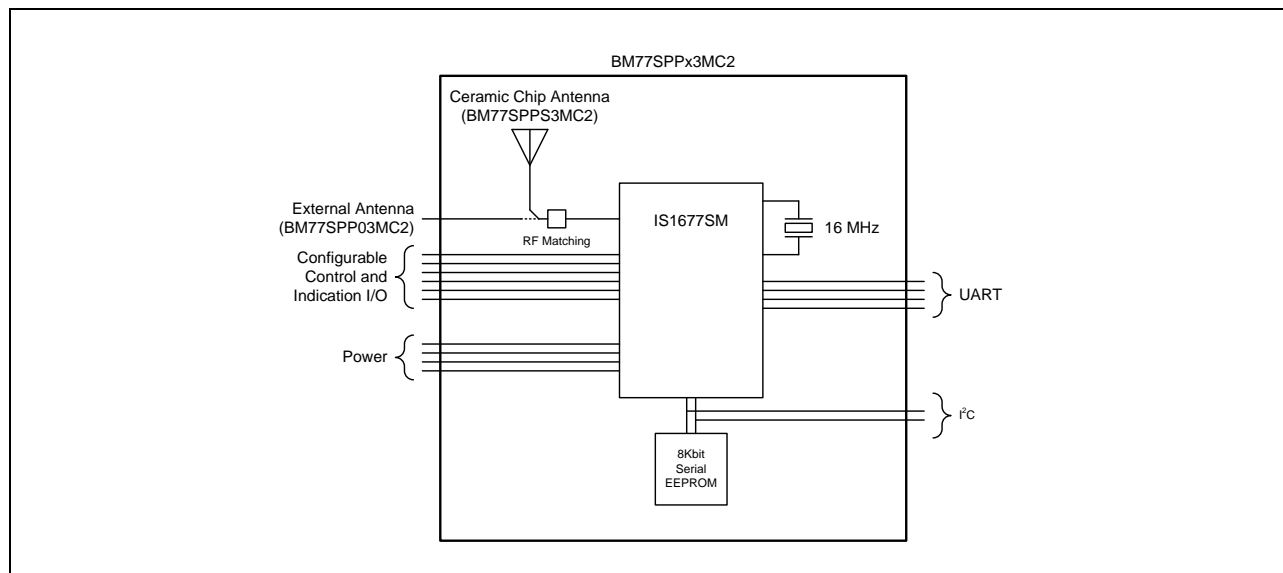

### 1.1 Interface Description

# BM77SPPx3MC2

The BM77SPPS3MC2 pin diagram is shown in Figure 1-2 and the BM77SPP03MC2 is shown in Figure 1-3. The pin descriptions are shown in Table 1-1

**FIGURE 1-2: BM77SPPS3MC2 PIN DIAGRAM**

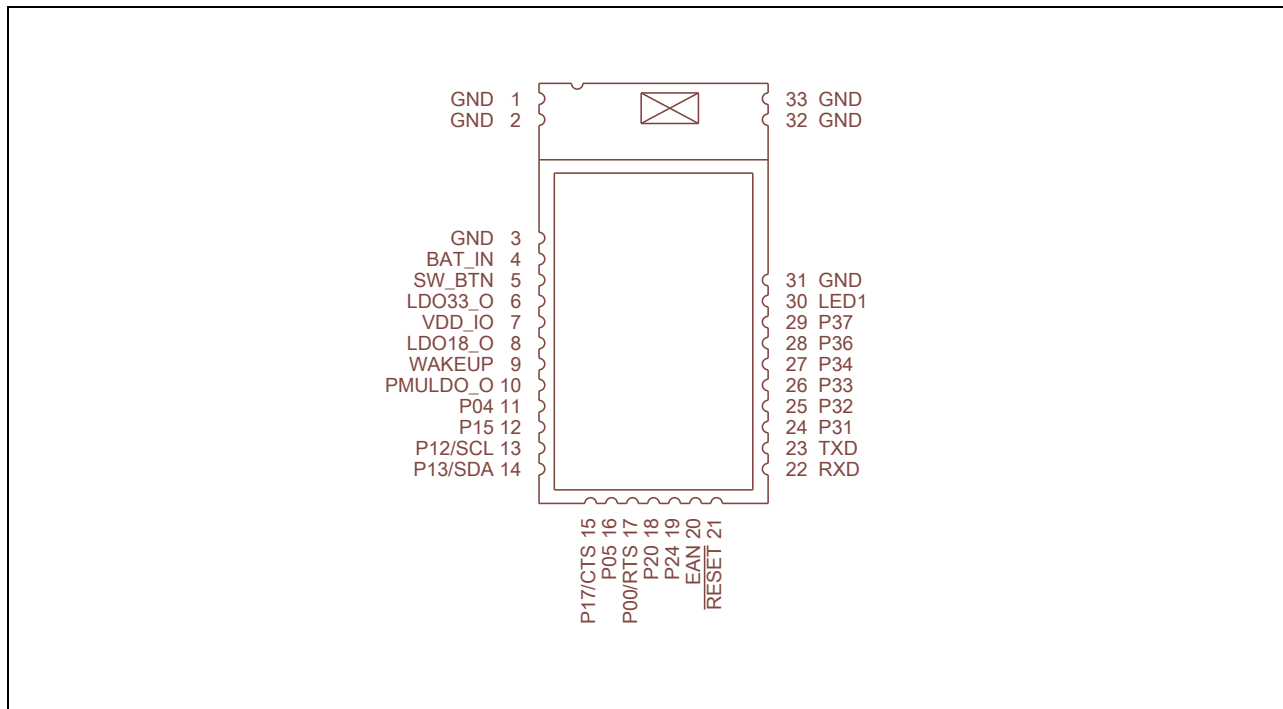

**FIGURE 1-3: BM77SPP03MC2 PIN DIAGRAM**

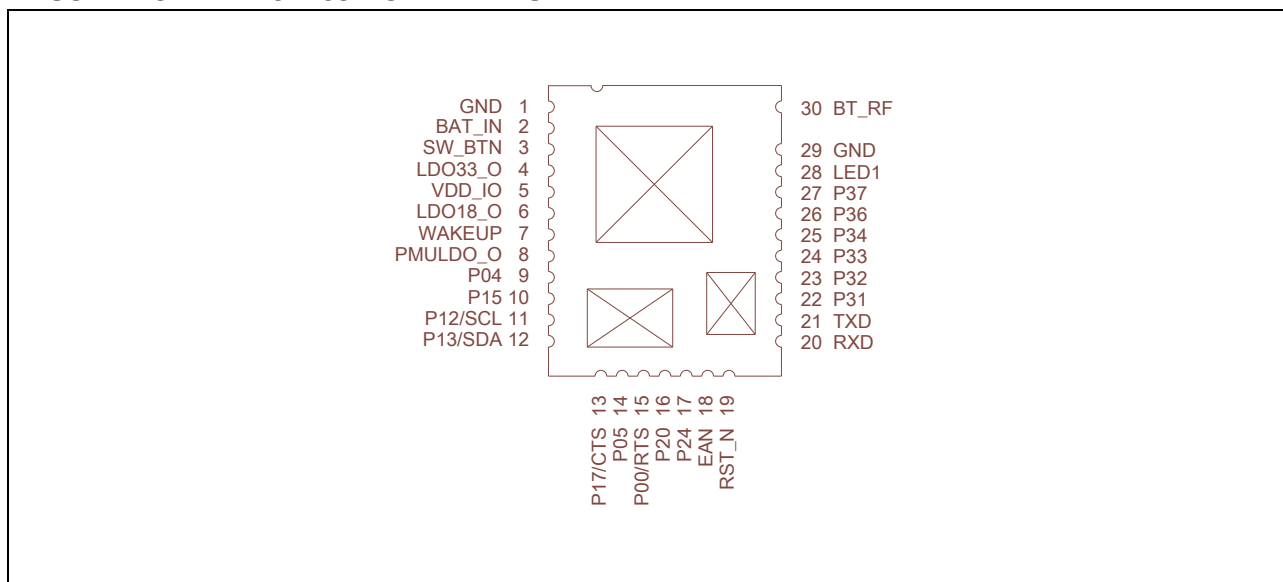

**TABLE 1-1: PIN DESCRIPTION**

BM77SPPS3MC2	BM77SPP03MC2	Symbol	Type	Description
--------------	--------------	--------	------	-------------

# BM77SPPx3MC2

Pin	Pin			
1	--	GND	Power	Ground reference
2	--	GND	Power	Ground reference
3	1	GND	Power	Ground reference
4	2	BAT_IN	Power	Battery Input. Main positive supply input. Connect to 10 uF low ESR ceramic capacitor.
5	3	SW_BTN	DI	Software Button H: Power On / L: Power Off (See Section 1.6)
6	4	LDO33_O	Power	Internal 3.3V LDO regulator output. Connect to 10 uF low ESR ceramic capacitor.
7	5	VDD_IO	Power	I/O positive supply input. Ensure VDD_IO and MCU I/O voltages are compatible.
8	6	LDO18_O	Power	Internal 1.8V LDO regulator output. Connect to 10 uF low ESR ceramic capacitor.
9	7	WAKEUP	DI	Wakeup from shutdown mode (active low) (internal pull-up)
10	8	PMULDO_O	Power	Power management unit output. Connect to 1 uF low ESR ceramic capacitor.
11	9	P04	DO	Status Indicator 2 (STATUS_IND_2). See Section 1.5
12	10	P15	DO	Status Indicator 1 (STATUS_IND_1). See Section 1.5
13	11	P12/SCL	DO	I <sup>2</sup> C SCL (Do Not Connect)
14	12	P13/SDA	DIO	I <sup>2</sup> C SDA (Do Not Connect)
15	13	P17/CTS	DIO	Configurable Control or Indication pin or UART CTS (input)
16	14	P05	DIO	Configurable Control or Indication pin
17	15	P00/RTS	DIO	Configurable Control or Indication pin or UART RTS (output)
18	16	P20	DI	System configuration (internal pull-up) (See Section 1.10)
19	17	P24	DI	System configuration (internal pull-up) (See Section 1.10)
20	18	EAN	DI	System configuration (internal pull-down) (See Section 1.10)
21	19	RST_N	DI	Module reset (active low) (internal pull-up) Apply a pulse of at least 63 ns.
22	20	RXD	DI	UART data input
23	21	TXD	DO	UART data output
24	22	P31	DIO	Configurable Control or Indication pin (when configured as input: internal pull-up)
25	23	P32	DIO	Configurable Control or Indication pin (when configured as input: internal pull-up)
26	24	P33	DIO	Configurable Control or Indication pin (when configured as input: internal pull-up)
27	25	P34	DIO	Configurable Control or Indication pin (when configured as input: internal pull-up)
28	26	P36	DIO	(Do Not Connect)
29	27	P37	DIO	Configurable Control or Indication pin (when configured as input: internal pull-up)
30	28	LED1	DO	Status LED (See Section 1.9)
31	29	GND	Power	Ground reference
--	30	BT_RF	AIO	External antenna connection (50 ohm)
32	--	GND	Power	Ground reference
33	--	GND	Power	Ground reference

**Note 1:** Pin type abbreviation: A = Analog, D = Digital, I = Input, O = Output.

## 1.2 Configuring the BM77

Configuring the BM77 features can be performed using either MCU commands documented in the *“ISSC Flash Protocol Programmer’s Guide,”* or with the *“Windows UI Configuration tool”* and *“Write EEPROM tool.”* MCU UART commands are documented in *“BM77SPP Command Set.”*

### 1.3 UART Interface

Figures 1-4 and 1-5 show Power and MCU interface examples.

The BM77 UART pins TXD and RXD connect to the UART pins of the host MCU. It is highly recommended to use hardware flow control pins RTS and CTS. The BM77 hardware flow control is disabled by default and must be configured to enable. The UART Baud is configurable. The available signal rates are listed in Table 4-5.

### 1.4 Control and Indication I/O Pins

I/O pins P00, P05, P17, P31, P32, P33, P34 and P37 are configurable control and indication I/O. Control signals are input to the BM77. Indication signals are output from the BM77. Table 1-2 shows configurable I/O pin assignment to control and indication signals. Note that RTS can only be assigned to P00 and CTS to P17.

**TABLE 1-2: CONFIGURATION AND INDICATION I/O ASSIGNMENTS**

	N/C	UART_RTS	UART_CTS	LOW_BATTERY_IND	LINK_QUALITY_IND	DISCONNECT_CONTROL	UART_RX_IND	DISCOVERY_CONTROL	INQUIRY CONTROL	PROFILE_IND
P00		Default								
P05	Default									
P17			Default							
P31									Default	
P32						Default				
P33	Default									
P34	Default									
P37				Default						

### 1.5 Status Indication I/O Pins

I/O pins P15 and P04 are Status Indicator 1 and 2 signals respectively. Together they provide status indication to the MCU as shown in Table 1-3.

**TABLE 1-3: STATUS INDICATION**

P04/STATUS_IND_2	P15/STATUS_IND_1	Indication
H	H	Power default / Shutdown state
H	L	Access state
L	H	Link state (no UART data being transmitted)
L	L	Link state (UART data being transmitted)

### 1.6 Software Button (SW\_BTN)

The Software Button (SW\_BTN) input pin powers the BM77 on (high) or off (low)

## 1.7 WAKE UP (WAKEUP)

The Wake Up (WAKEUP) input pin wakes the BM77 from shutdown mode (active low).

## 1.8 RESET (RST\_N)

The Reset (RST\_N) input pin resets the BM77 (active low pulse for at least 63 ns).

## 1.9 Status LED (LED1)

The status LED (LED1) indicates:

- Standby
- Inquiry
- Link
- Link Back
- Low Battery
- Page

Each indication is a configurable flashing sequence. LED brightness can also be configured.

## 1.10 System Configuration

I/O pins P20, P24, and EAN place the BM77 into operation modes as shown in Table 1-4. P20 and P24 each have internal pull-ups. EAN has internal pull-down.

**TABLE 1-4: SYSTEM CONFIGURATION SETTINGS**

P20	P24	EAN	Operational Mode
High	High	Low	Normal operation
Low	High	Low	Test (Write EEPROM)
Low	Low	High	Write Flash (Firmware programming)

## 1.11 Power

Figure 1-4 shows an example power scheme using a 3.3 volt low-dropout (LDO) regulator supplying 3.3 volts to both the BM77 (BAT\_IN and VDD\_IO) and MCU VDD. This power scheme ensures that BM77 and MCU I/O voltages are compatible.

Figure 1-5 shows an example power scheme using a 3.7 volt lithium-ion battery. The BM77 has an internal 3.3 volt LDO regulator. Battery power is applied to BAT\_IN pin. The regulated 3.3 volts output is on the LDO33\_O pin. From the LDO33\_O pin, voltage can be routed the VDD\_IO pin and external circuitry including the MCU. This power scheme ensures that BM77 and MCU I/O voltages are compatible.

**CAUTION:** The internal 3.3 volt LDO current source: 50 mA maximum

Recommended bypass capacitor location and values are shown in Figures 1-4 and 1-5. Capacitors can be low ESR ceramic. Place capacitors close to BM77 module.

### FIGURE 1-4: BM77 TO MCU INTERFACE EXAMPLE – LDO

**FIGURE 1-5: BM77 TO MCU INTERFACE EXAMPLE – BATTERY**

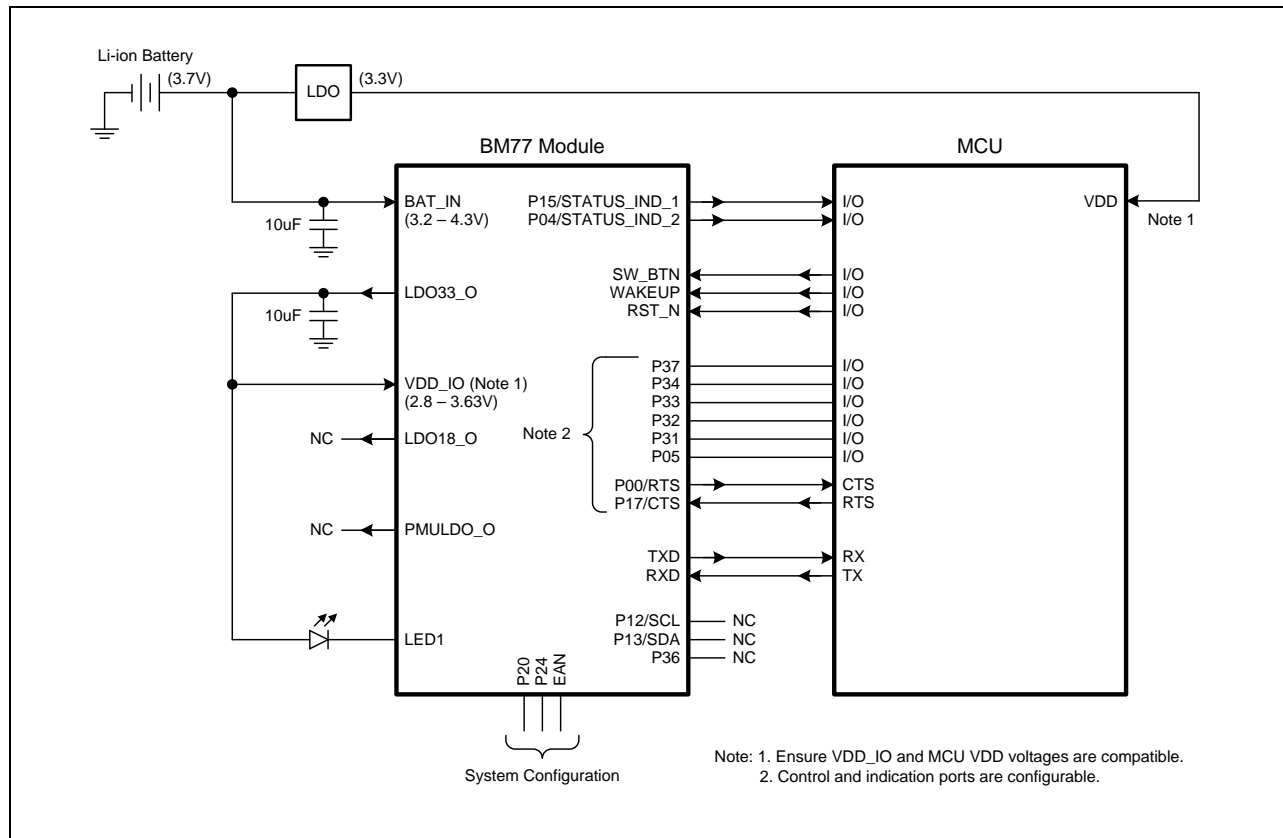

## 1.12 Mounting Details

The BM77SPP3MC2 physical dimensions are shown in Figure 1-6, recommended host PCB footprint in Figure 1-7, and mounting suggestion in Figure 1-8. There should not be top copper layer near the test pin area shown in Figure 1-7. When laying out the host PCB, the areas under the antenna should not contain any top, inner layer, or bottom copper as shown in Figure 1-8. A low-impedance ground plane will ensure best radio performance (best range, lowest noise). Figure 1-8 shows a minimum ground plane area to the left and right of the module for best antenna performance. The ground plane can be extended beyond the minimum recommended as need for host PCB EMC noise reduction. For best range performance, keep all external metal away from the ceramic chip antenna at least 31 mm.

The BM77SPP03MC2 physical dimensions are shown in Figure 1-9, recommended host PCB footprint in Figure 1-10, and mounting suggestion in Figure 1-11. It is highly recommended to layout the host PCB as suggested in Figure 1-11. A low-impedance ground plane will ensure best radio performance (best range, lowest noise). Pin 30 (BT\_RF) is a 50 ohm connection to an external antenna connector, PCB trace antenna, or component (ceramic chip) antenna through a host PCB 50 ohm micro-strip trace. This trace can be extended to include passive parts for antenna attenuation padding, impedance matching, or to provide test posts. It is recommended that the micro-strip trace be as short as possible for minimum loss and best impedance matching. If the micro-strip trace is longer, it should be a 50 ohm impedance. Figure 1-11 shows an example connection to U.FL connector.

## 1.13 Soldering Recommendations

The BM77 wireless module was assembled using standard lead-free reflow profile IPC/JEDEC J-STD-020. The module can be soldered to the host PCB using standard leaded and lead-free solder reflow profiles. To avoid damaging the module, the following recommendations are given:

- Microchip Technology Application Note AN233 Solder Reflow Recommendation (DS00233) provides solder reflow recommendations
- Do not exceed peak temperature ( $T_p$ ) of 250 deg C
- Refer to the solder paste data sheet for specific reflow profile recommendations
- Use no-clean flux solder paste
- Do not wash as moisture can be trapped under the shield
- Use only one flow. If the PCB requires multiple flows, apply the module on the final flow.



**FIGURE 1-6: BM77SPPS3MCS MODULE DIMENSIONS**

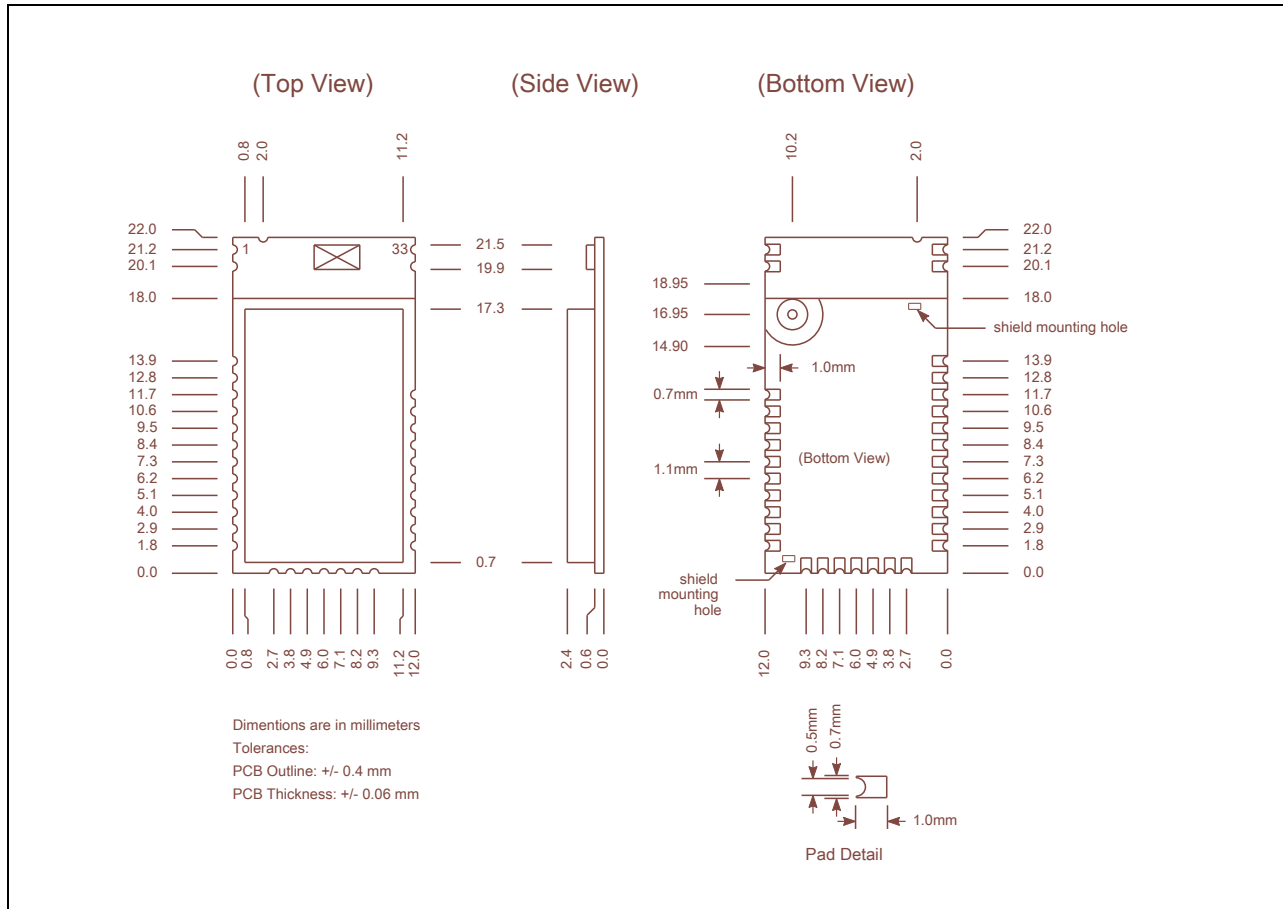

**FIGURE 1-7: BM77SPPS3MC2 RECOMMENDED PCB FOOTPRINT**

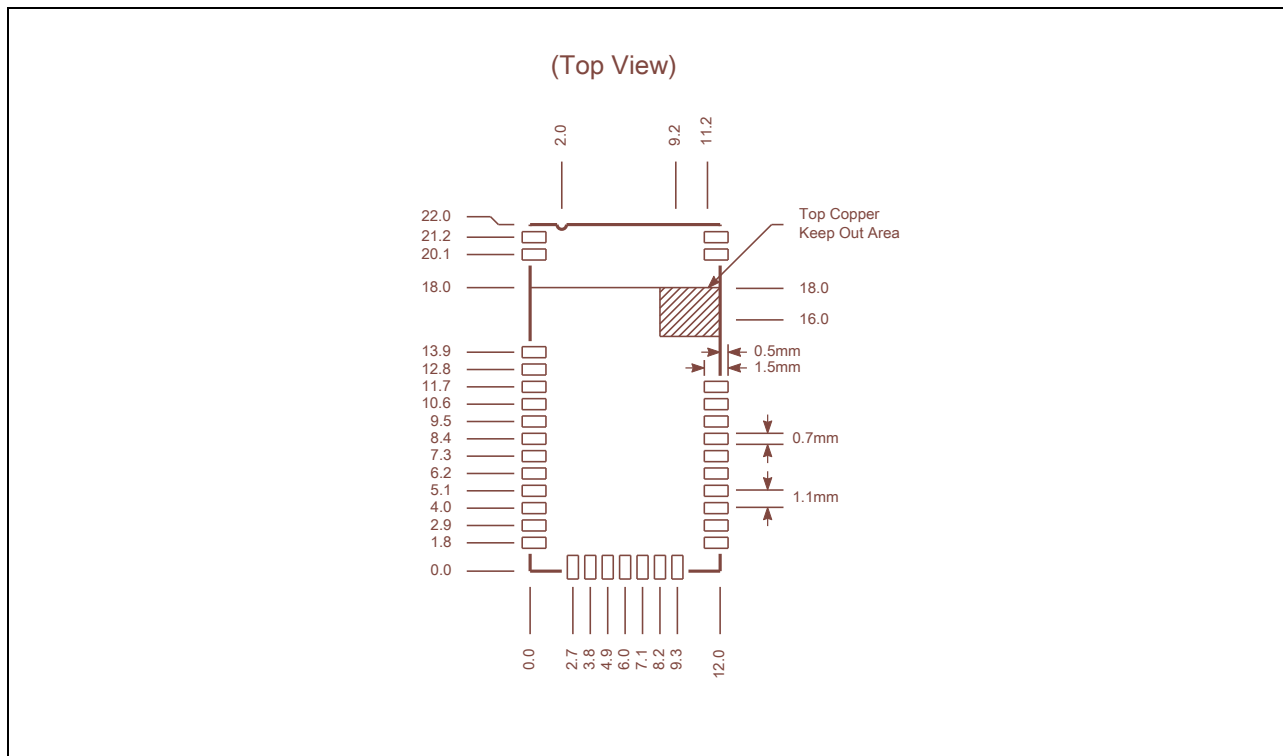
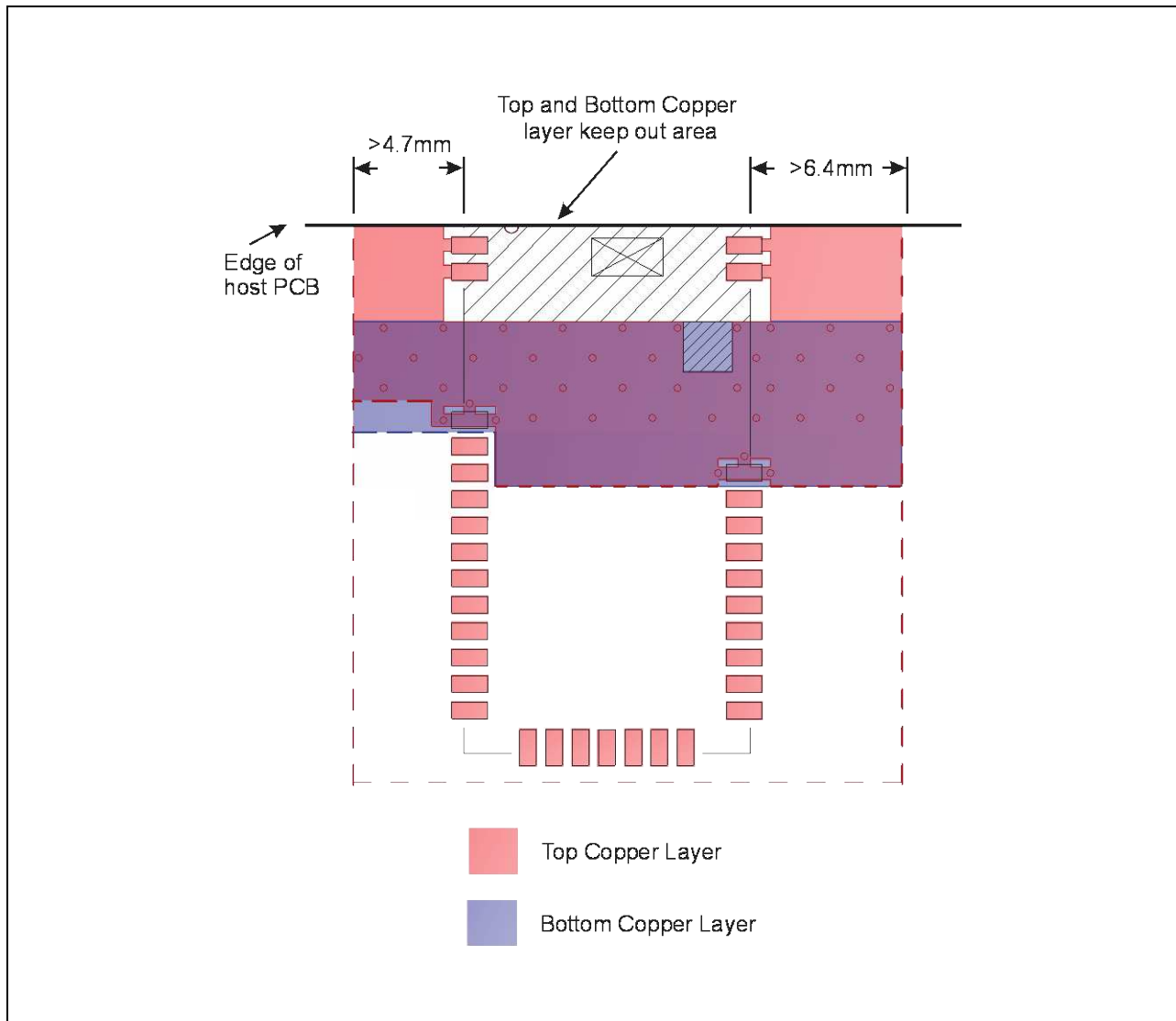
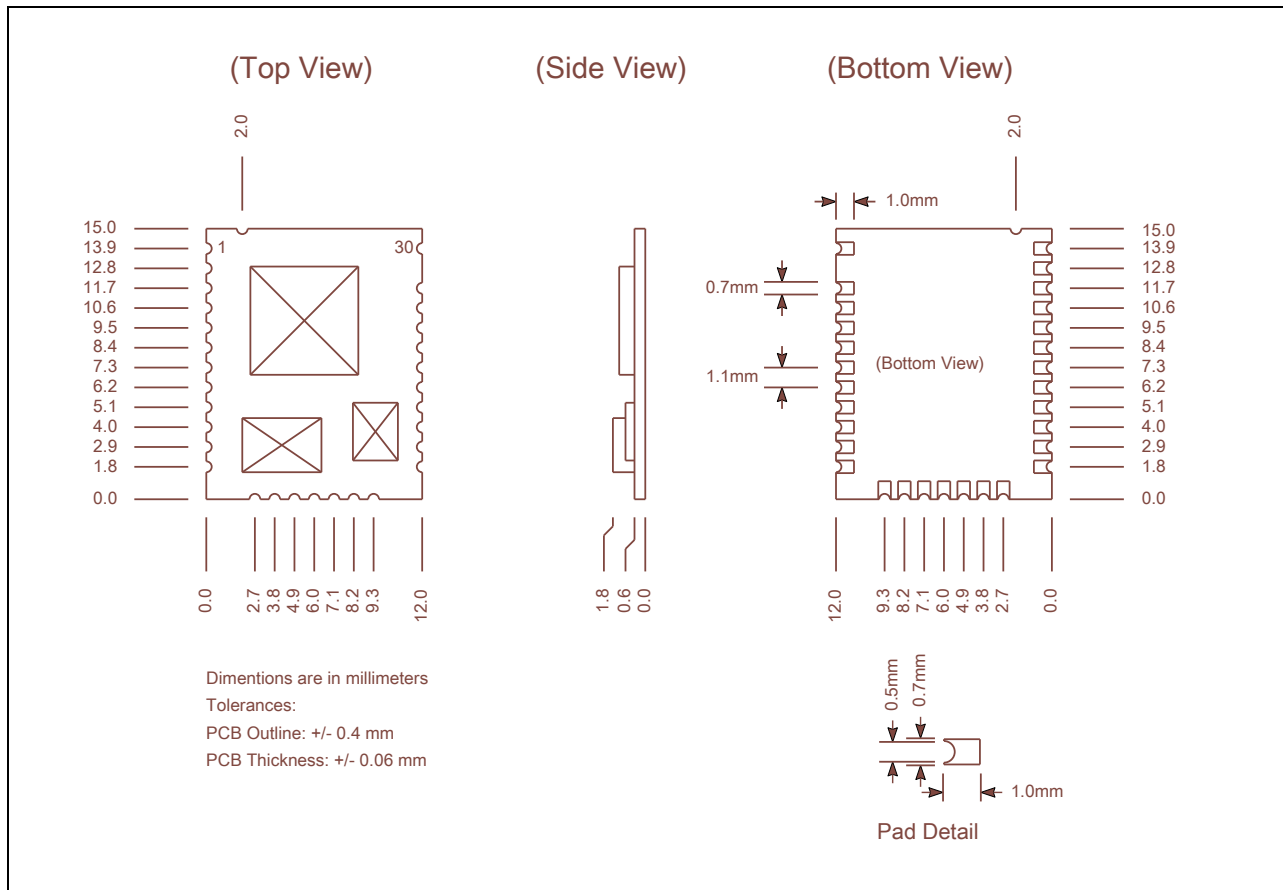

FIGURE 1-8: BM77SPPS3MCS HOST PCB MOUNTING SUGGESTION



**FIGURE 1-9: BM77SPP03MCS MODULE DIMENSIONS**



**FIGURE 1-10: BM77SPP03MC2 RECOMMENDED PCB FOOTPRINT**

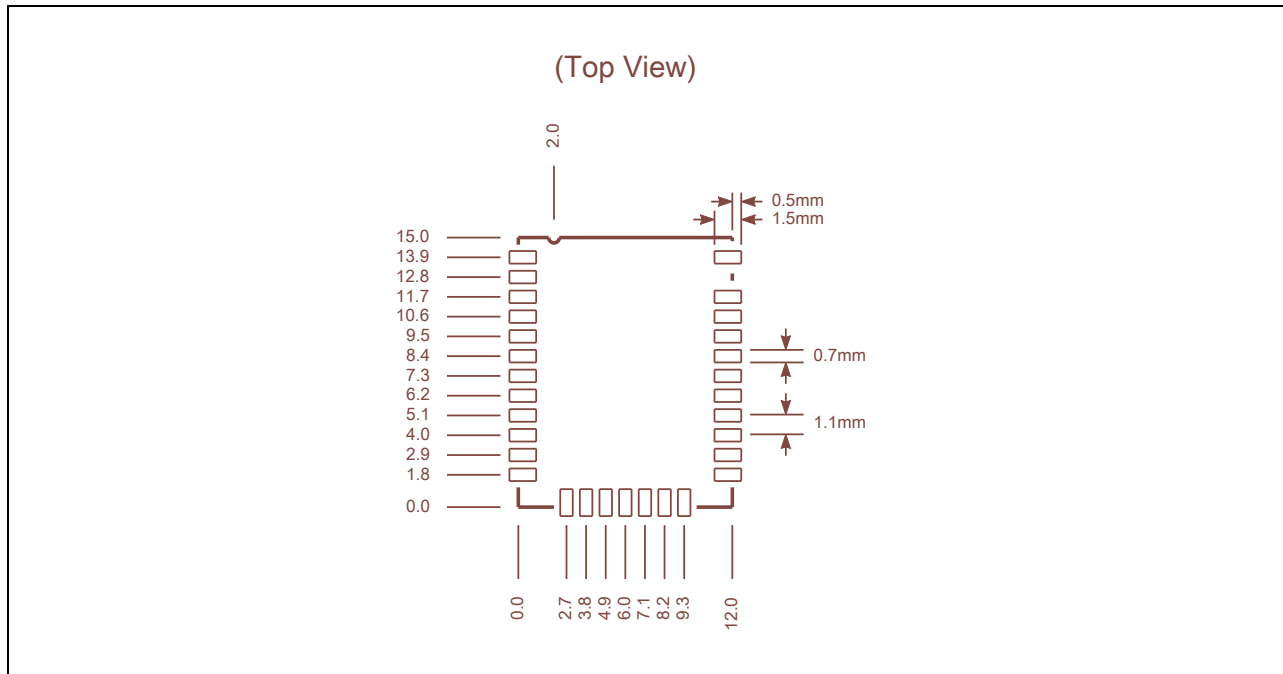
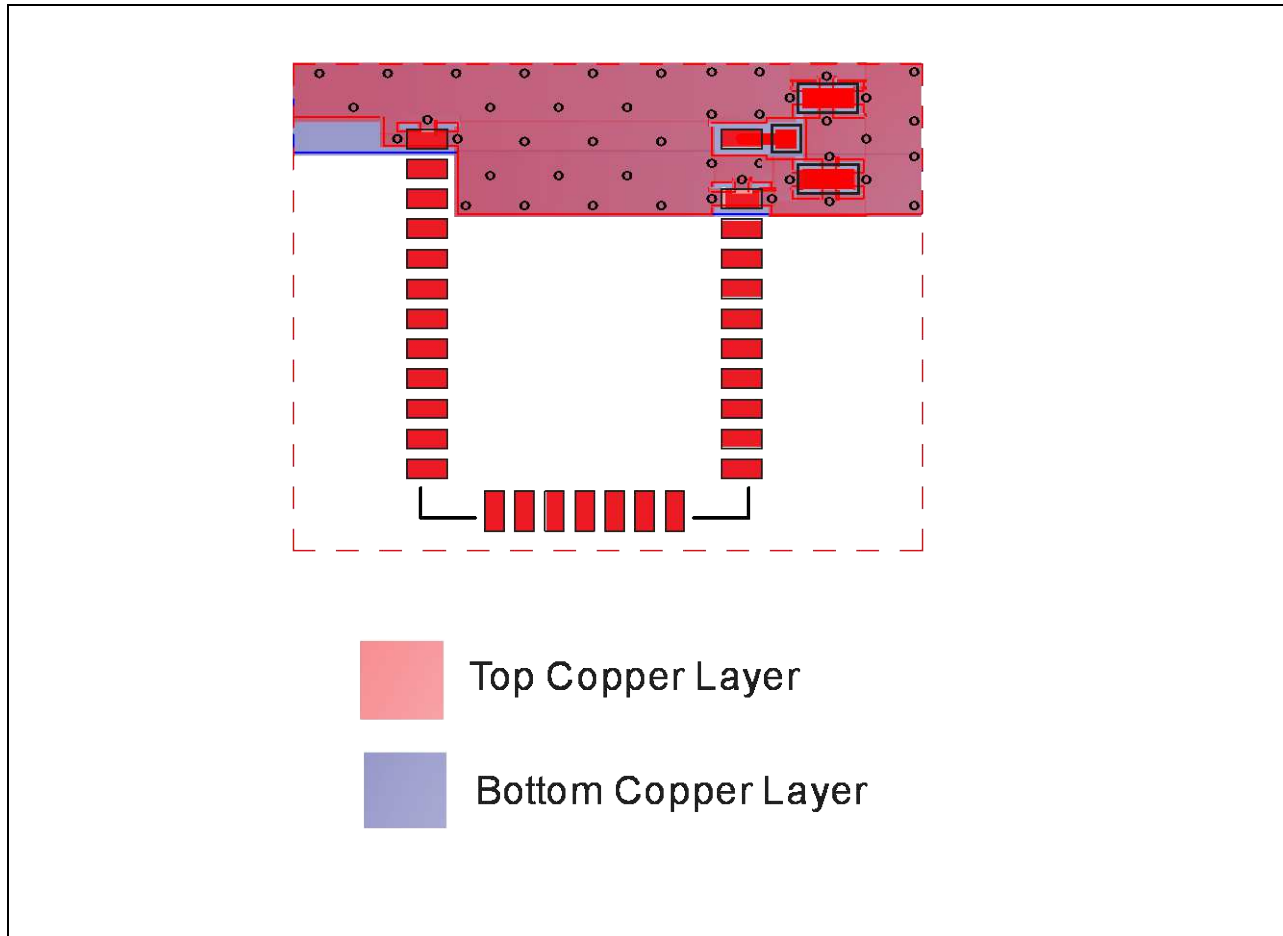

FIGURE 1-11: BM77SPP03MCS HOST PCB MOUNTING SUGGESTION



## 2.0 APPLICATION INFORMATION

### 2.2 BM77SPPS3MC2 Ceramic Chip Antenna

The BM77SPPS3MC2 module contains an integral ceramic chip antenna. The antenna performance on the module is shown in Figure 2-1.

**FIGURE 2-1: BM77SPPS3MC2 ANTENNA RADIATION PATTERN**

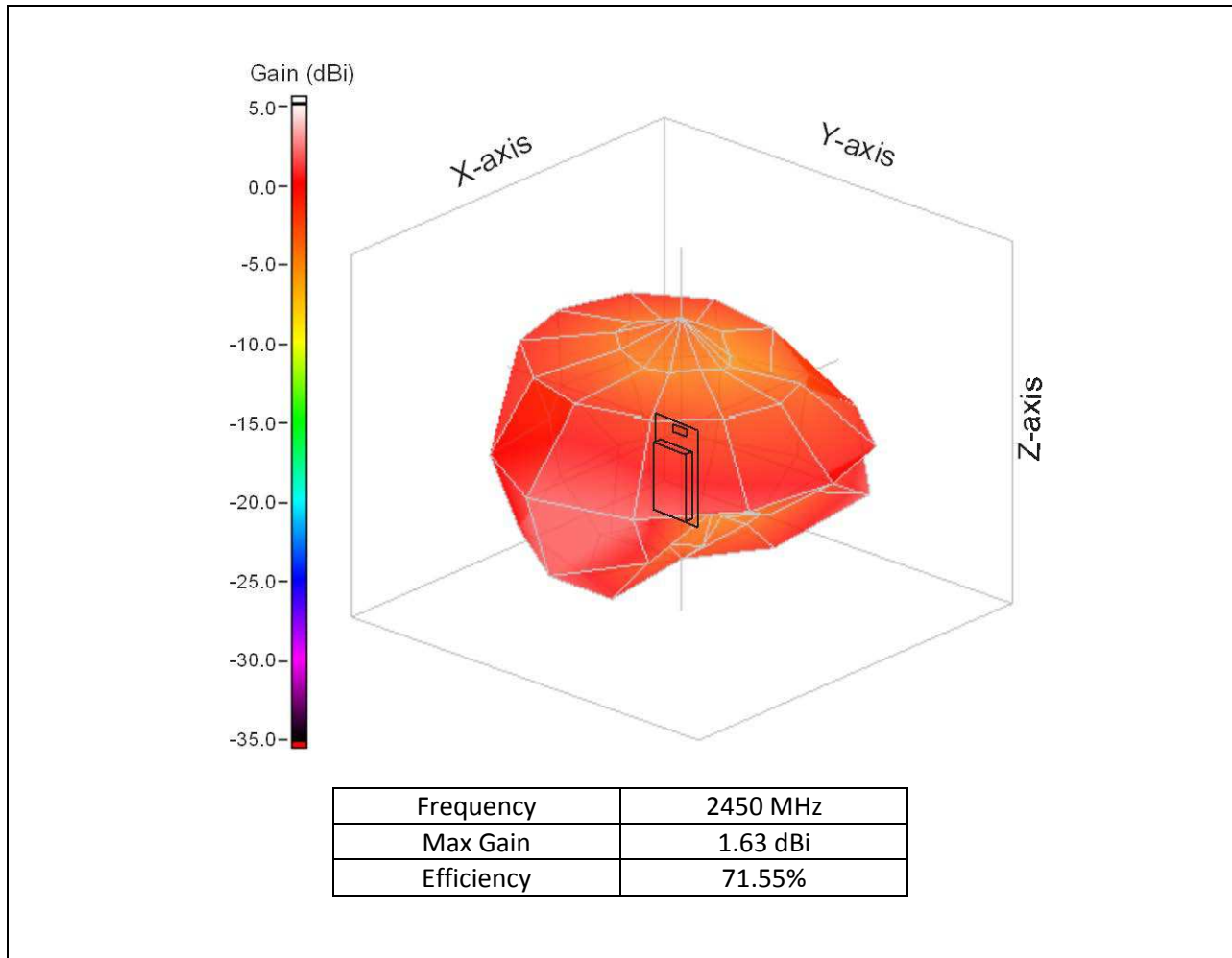

## 2.3 External Configuration and Programming

The BM77 module can be configured and firmware programmed using an external configuration and programming tool available from ISSC Technologies. Figure 2-2 shows the connections between the BM77 and header J1, a standard 8-pin 0.100" (2.54 mm) spaced header. It is recommended to include this header on the host PCB for development.

Configuration and firmware programming modes are entered according to the system configuration I/O pins (see Section 1.8).

**FIGURE 2-2: EXTERNAL PROGRAMMING HEADER CONNECTIONS**

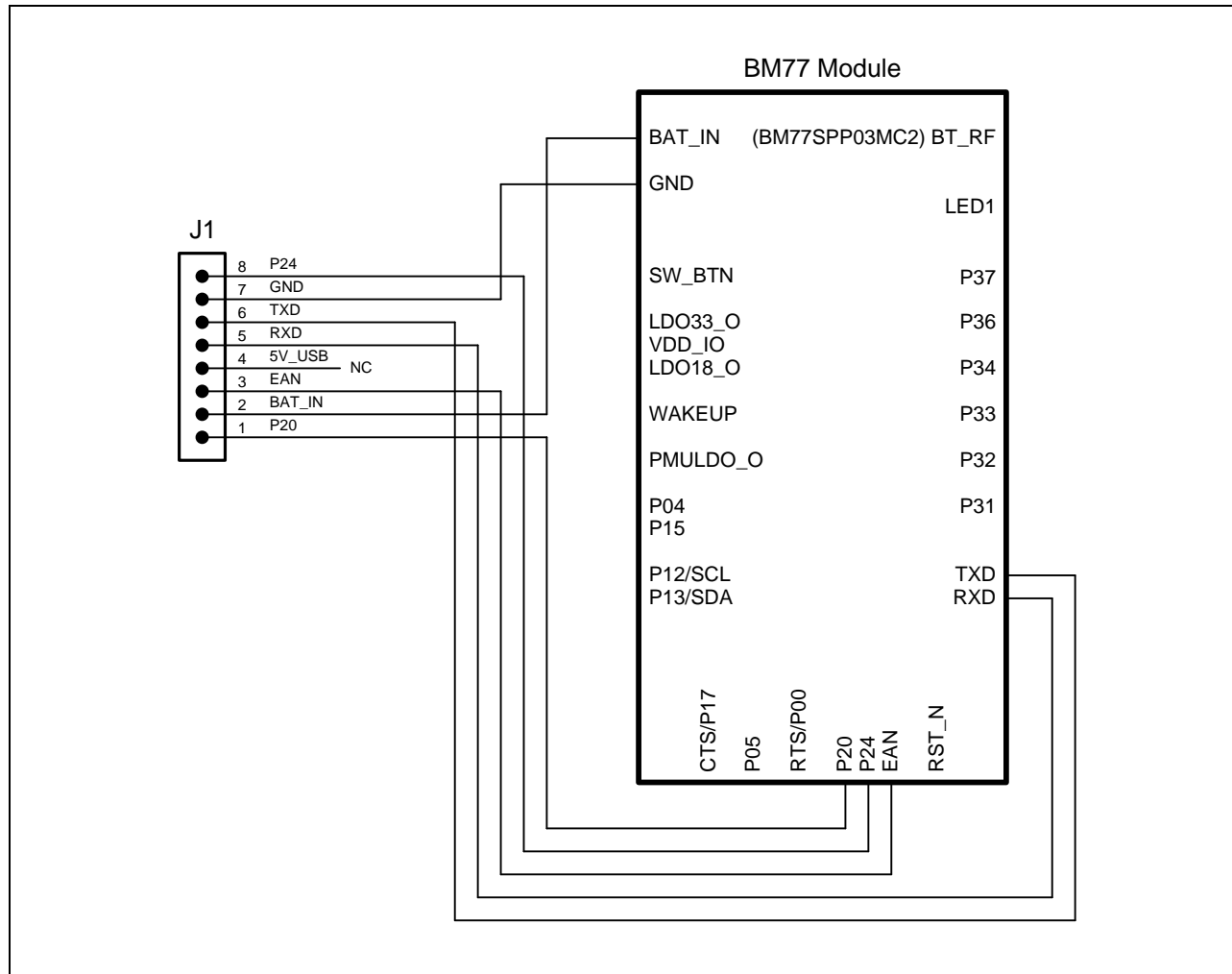

## 3.0 REGULATORY APPROVAL

This section outlines the regulatory information for the BM77SSPS3MC2 module for the following countries:

- United States
- Canada
- Europe
- Australia
- New Zealand
- Japan
- Korea
- Taiwan
- Other Regulatory Jurisdictions

### 3.2 United States

The BM77SSPS3MC2 module has received Federal Communications Commission (FCC) CFR47 Telecommunications, Part 15 Subpart C “Intentional Radiators” modular approval in accordance with Part 15.212 Modular Transmitter approval. Modular approval allows the end user to integrate the BM77 module into a finished product without obtaining subsequent and separate FCC approvals for intentional radiation, provided no changes or modifications are made to the module circuitry. Changes or modifications could void the user’s authority to operate the equipment. The end user must comply with all of the instructions provided by the Grantee, which indicate installation and/or operating conditions necessary for compliance.

The finished product is required to comply with all applicable FCC equipment authorizations regulations, requirements and equipment functions not associated with the transmitter module portion. For example, compliance must be demonstrated to regulations for other transmitter components within the host product; to requirements for unintentional radiators (Part 15 Subpart B “Unintentional Radiators”), such as digital devices, computer peripherals, radio receivers, etc.; and to additional authorization requirements for the non-transmitter functions on the transmitter module (i.e., Verification, or Declaration of Conformity) (e.g., transmitter modules may also contain digital logic functions) as appropriate.

#### 3.2.1 LABELING AND USER INFORMATION REQUIREMENTS

The BM77 module has been labeled with its own FCC ID number, and if the FCC ID is not visible when the module is installed inside another device, then the outside of the finished product into which the module is installed must also display a label referring to the enclosed module. This exterior label can use wording as follows:

Contains Transmitter Module FCC ID: A8TBM77SPPSYC2A  
or  
Contains FCC ID: A8TBM77SPPSYC2A

This device complies with Part 15 of the FCC Rules. Operation is subject to the following two conditions: (1) this device may not cause harmful interference, and (2) this device must accept any interference received, including interference that may cause undesired operation

A user's manual for the finished product should include the following statement:

This equipment has been tested and found to comply with the limits for a Class B digital device, pursuant to part 15 of the FCC Rules. These limits are designed to provide reasonable protection against harmful interference in a residential installation. This equipment generates, uses and can radiate radio frequency energy, and if not installed and used in accordance with the instructions, may cause harmful interference to radio communications. However, there is no guarantee that interference will not occur in a particular installation. If this equipment does cause harmful interference to radio or television reception, which can be determined by turning the equipment off and on, the user is encouraged to try to correct the interference by one or more of the following measures:

- Reorient or relocate the receiving antenna.
- Increase the separation between the equipment and receiver.
- Connect the equipment into an outlet on a circuit different from that to which the receiver is connected.
- Consult the dealer or an experienced radio/TV technician for help.

Additional information on labeling and user information requirements for Part 15 devices can be found in KDB Publication 784748 available at the FCC Office of Engineering and Technology (OET) Laboratory Division Knowledge Database (KDB) <http://apps.fcc.gov/oetcf/kdb/index.cfm>.

### 3.2.2 RF EXPOSURE

All transmitters regulated by FCC must comply with RF exposure requirements. KDB 447498 General RF Exposure Guidance provides guidance in determining whether proposed or existing transmitting facilities, operations or devices comply with limits for human exposure to Radio Frequency (RF) fields adopted by the Federal Communications Commission (FCC).

From the FCC Grant: Output power listed is conducted. This grant is valid only when the module is sold to OEM integrators and must be installed by the OEM or OEM integrators. This transmitter is restricted for use with the specific antenna(s) tested in this application for Certification and must not be co-located or operating in conjunction with any other antenna or transmitters within a host device, except in accordance with FCC multi-transmitter product procedures.

### 3.2.3 HELPFUL WEB SITES

Federal Communications Commission (FCC): <http://www.fcc.gov>  
FCC Office of Engineering and Technology (OET) Laboratory Division Knowledge Database (KDB): <http://apps.fcc.gov/oetcf/kdb/index.cfm>



## 3.3 Canada

The BM77SSPS3MC2 module has been certified for use in Canada under Industry Canada (IC) Radio Standards Specification (RSS) RSS-210 and RSS-Gen. Modular approval permits the installation of a module in a host device without the need to recertify the device.

### 3.3.1 LABELING AND USER INFORMATION REQUIREMENTS

Labeling Requirements for the Host Device (from Section 3.2.1, RSS-Gen, Issue 3, December 2010): The host device shall be properly labeled to identify the module within the host device.

The Industry Canada certification label of a module shall be clearly visible at all times when installed in the host device, otherwise the host device must be labeled to display the Industry Canada certification number of the module, preceded by the words “Contains transmitter module”, or the word “Contains”, or similar wording expressing the same meaning, as follows:

Contains transmitter module IC: 12246A-BM77SPSYC2

User Manual Notice for License-Exempt Radio Apparatus (from Section 7.1.3 RSS-Gen, Issue 3, December 2010): User manuals for license-exempt radio apparatus shall contain the following or equivalent notice in a conspicuous location in the user manual or alternatively on the device or both:

This device complies with Industry Canada license-exempt RSS standard(s). Operation is subject to the following two conditions: (1) this device may not cause interference, and (2) this device must accept any interference, including interference that may cause undesired operation of the device.

Le présent appareil est conforme aux CNR d'Industrie Canada applicables aux appareils radio exempts de licence. L'exploitation est autorisée aux deux conditions suivantes: (1) l'appareil ne doit pas produire de brouillage, et (2) l'utilisateur de l'appareil doit accepter tout brouillage radioélectrique subi, même si le brouillage est susceptible d'en compromettre le fonctionnement.

Transmitter Antenna (from Section 7.1.2 RSS-Gen, Issue 3, December 2010): User manuals for transmitters shall display the following notice in a conspicuous location:

Under Industry Canada regulations, this radio transmitter may only operate using an antenna of a type and maximum (or lesser) gain approved for the transmitter by Industry Canada. To reduce potential radio interference to other users, the antenna type and its gain should be so chosen that the equivalent isotropically radiated power (e.i.r.p.) is not more than that necessary for successful communication.

Conformément à la réglementation d'Industrie Canada, le présent émetteur radio peut fonctionner avec une antenne d'un type et d'un gain maximal (ou inférieur) approuvé pour l'émetteur par Industrie Canada. Dans le but de réduire les risques de brouillage radioélectrique à l'intention des autres utilisateurs, il faut choisir le type d'antenne et son gain de sorte que la puissance isotrope rayonnée équivalente (p.i.r.e.) ne dépasse pas l'intensité nécessaire à l'établissement d'une communication satisfaisante.

The above notice may be affixed to the device instead of displayed in the user manual. User manuals for transmitters equipped with detachable antennas shall also contain the following notice in a conspicuous location:

This radio transmitter (identify the device by certification number, or model number if Category II) has been approved by Industry Canada to operate with the antenna types listed below with the maximum permissible gain and required antenna impedance for each antenna type indicated. Antenna types not included in this list, having a gain greater than the maximum gain indicated for that type, are strictly prohibited for use with this device.

Conformément à la réglementation d'Industrie Canada, le présent émetteur radio peut fonctionner avec une antenne d'un type et d'un gain maximal (ou inférieur) approuvé pour l'émetteur par Industrie Canada. Dans le but de réduire les risques de brouillage radioélectrique à l'intention des autres utilisateurs, il faut choisir le type d'antenne et son gain de sorte que la puissance isotrope rayonnée équivalente (p.i.r.e.) ne dépasse pas l'intensité nécessaire à l'établissement d'une communication satisfaisante.

Immediately following the above notice, the manufacturer shall provide a list of all antenna types approved for use with the transmitter, indicating the maximum permissible antenna gain (in dBi) and required impedance for each.

### 3.3.2 RF EXPOSURE

All transmitters regulated by IC must comply with RF exposure requirements listed in RSS-102 - Radio Frequency (RF) Exposure Compliance of Radiocommunication Apparatus (All Frequency Bands).

*(Get direct quote from Certificate and place here)*

### 3.3.3 HELPFUL WEB SITES

Industry Canada: <http://www.ic.gc.ca/>

### 3.4 Europe

The BM77SPPx3MC2 module is an R&TTE Directive assessed radio module that is CE marked and has been manufactured and tested with the intention of being integrated into a final product.

The BM77 module has been tested to R&TTE Directive 1999/5/EC Essential Requirements for Health and Safety (Article (3.1(a)), Electromagnetic Compatibility (EMC) (Article 3.1(b)), and Radio (Article 3.2) and are summarized in **Table 3-1: European Compliance Testing**. A Notified Body Opinion has also been issued. All test reports are available on the BM77 product web page at <http://www.microchip.com/bm77>.

The R&TTE Compliance Association provides guidance on modular devices in document **Technical Guidance Note 01** available at [http://www.rttte.ca/html/download\\_area.htm](http://www.rttte.ca/html/download_area.htm).

**Note:** To maintain conformance to the testing listed in **Table 3-1: European Compliance Testing**, the module shall be installed in accordance with the installation instructions in this data sheet and shall not be modified.

When integrating a radio module into a completed product the integrator becomes the manufacturer of the final product and is therefore responsible for demonstrating compliance of the final product with the essential requirements of the R&TTE Directive.

#### 3.4.1 LABELING AND USER INFORMATION REQUIREMENTS

The label on the final product which contains the BM77 module must follow CE marking requirements. The R&TTE Compliance Association **Technical Guidance Note 01** provides guidance on final product CE marking.

#### 3.4.2 ANTENNA REQUIREMENTS

From R&TTE Compliance Association document **Technical Guidance Note 01**:

Provided the integrator installing an assessed radio module with an integral or specific antenna and installed in conformance with the radio module manufacturer's installation instructions requires no further evaluation under Article 3.2 of the R&TTE Directive and does not require further involvement of an R&TTE Directive Notified Body for the final product. [Section 2.2.4]

The European Compliance Testing listed in **Table 3-1** was performed using the integral ceramic chip antenna.

**TABLE 3-1: EUROPEAN COMPLIANCE TESTING**

Certification	Standards	Article	Laboratory	Report Number	Date
Safety	EN 60950-1:2006+A11:2009+A1:2010	(3.1(a))			
Health	EN 50371:2002-03				
EMC	EN 301 489-1 V1.8.1 (2008-04)	(3.1(b))			
	EN 301 489-17 V2.1.1 (2009-05)				
Radio	EN 300 328 V1.7.1 (2006-10)	(3.2)			
Notified Body Opinion					

### 3.4.3 HELPFUL WEB SITES

A document that can be used as a starting point in understanding the use of Short Range Devices (SRD) in Europe is the European Radio Communications Committee (ERC) Recommendation 70-03 E, which can be downloaded from the European Radio Communications Office (ERO) at: <http://www.ero.dk/>.

Additional helpful web sites are:

- Radio and Telecommunications Terminal Equipment (R&TTE):  
[http://ec.europa.eu/enterprise/rtte/index\\_en.htm](http://ec.europa.eu/enterprise/rtte/index_en.htm)
- European Conference of Postal and Telecommunications Administrations (CEPT):  
<http://www.cept.org>
- European Telecommunications Standards Institute (ETSI):  
<http://www.etsi.org>
- European Radio Communications Office (ERO):  
<http://www.ero.dk>
- The Radio and Telecommunications Terminal Equipment Compliance Association (R&TTE CA):  
<http://www.rtteca.com/>

### 3.5 Australia

The Australia radio regulations do not provide a modular approval policy similar to the United States (FCC) and Canada (IC). However, BM77 module RF transmitter test reports can be used in part to demonstrate compliance in accordance with ACMA Radio communications “Short Range Devices” Standard 2004 (The Short Range Devices standard calls up the AS/NZS 4268:2008 industry standard). The BM77 module test reports can be used as part of the product certification and compliance folder. For more information on the RF transmitter test report, contact Microchip Technology Australia sales office.

To meet overall Australian final product compliance, the developer must construct a compliance folder containing all relevant compliance test reports e.g. RF, EMC, electrical safety and DoC (Declaration of Conformity) etc. It is the responsibility of the integrator to know what is required in the compliance folder for ACMA compliance. All test reports are available on the BM77 product web page at <http://www.microchip.com>. For more information on Australia compliance, refer to the Australian Communications and Media Authority web site <http://www.acma.gov.au/>.

#### 3.5.1 HELPFUL WEB SITES

The Australian Communications and Media Authority: [www.acma.gov.au/](http://www.acma.gov.au/).

### 3.6 New Zealand

The New Zealand radio regulations do not provide a modular approval policy similar to the United States (FCC) and Canada (IC). However, BM77 module RF transmitter test reports can be used in part to demonstrate compliance against the New Zealand “General User Radio” series for “Short Range Devices”. New Zealand Radio communications (Radio Standards) Notice 2010 calls up the AS / NZS 4268:2008 industry standard. The BM77 module test reports can be used as part of the product

certification and compliance folder. All test reports are available on the BM77 product web page at <http://www.microchip.com/bm77>. For more information on the RF transmitter test reports, contact Microchip Technology sales office.

Information on the New Zealand short range devices license can be found in the following web links: <http://www.rsm.govt.nz/cms/licensees/types-oflicence/general-user-licences/short-range-devices>

and

<http://www.rsm.govt.nz/cms/policy-and-planning/spectrum-policy-overview/legislation/gazette-notices/product-compliance/> .

To meet overall New Zealand final product compliance, the developer must construct a compliance folder containing all relevant compliance test reports e.g. RF, EMC, electrical safety and DoC (Declaration of Conformity) etc. It is the responsibility of the developer to know what is required in the compliance folder for New Zealand Radio communications. For more information on New Zealand compliance, refer to the web site <http://www.rsm.govt.nz/>.

### 3.6.1 HELPFUL WEB SITES

Radio Spectrum Ministry of Economic Development: <http://www.rsm.govt.nz/>.

## 3.7 Japan

The BM77SSPS3MC2 module has received type certification and is labeled with its own technical conformity mark and certification number as required to conform to the technical standards regulated by the Ministry of Internal Affairs and Communications (MIC) of Japan pursuant to the Radio Act of Japan.

Integration of this module into a final product does not require additional radio certification provided installation instructions are followed and no modifications of the module are allowed. Additional testing may be required:

- If the host product is subject to electrical appliance safety (for example, powered from an AC mains), the host product may require Product Safety Electrical Appliance and Material (PSE) testing. The integrator should contact their conformance laboratory to determine if this testing is required.
- There is an voluntary Electromagnetic Compatibility (EMC) test for the host product administered by VCCI: [http://www.vcci.jp/vcci\\_e/index.html](http://www.vcci.jp/vcci_e/index.html)

### 3.7.1 LABELING AND USER INFORMATION REQUIREMENTS

The label on the final product which contains the BM77 module must follow Japan marking requirements. The integrator of the module should refer to the labeling requirements for Japan available at the Ministry of Internal Affairs and Communications (MIC) website.

The BM77 module is labeled with its own technical conformity mark and certification number. The final product in which this module is being used must have a label referring to the type certified module inside:

Contains transmitter module with certificate number:



202-SMC066

### 3.7.2 HELPFUL WEB SITES

Ministry of Internal Affairs and Communications (MIC): <http://www.tele.soumu.go.jp/e/index.htm>

Association of Radio Industries and Businesses (ARIB): <http://www.arib.or.jp/english/>

## 3.8 Korea

The BM77SSPS3MC2 module has received certification of conformity in accordance with the Radio Waves Act. Integration of this module into a final product does not require additional radio certification provided installation instructions are followed and no modifications of the module are allowed.

### 3.8.1 LABELING AND USER INFORMATION REQUIREMENTS

The label on the final product which contains the BM77 module must follow KC marking requirements. The integrator of the module should refer to the labeling requirements for Korea available on the Korea Communications Commission (KCC) website.

The BM77 module is labeled with its own KC mark. The final product requires the KC mark and certificate number of the module:



### 3.8.2 HELPFUL WEB SITES

Korea Communications Commission (KCC): <http://www.kcc.go.kr>

National Radio Research Agency (RRA): <http://rra.go.kr>

## 3.9 Taiwan

The BM77SSPS3MC2 module has received compliance approval in accordance with the Telecommunications Act. Customers seeking to use the compliance approval in their product should contact Microchip Technology sales or distribution partners to obtain a Letter of Authority.

Integration of this module into a final product does not require additional radio certification provided installation instructions are followed and no modifications of the module are allowed.

### 3.9.1 LABELING AND USER INFORMATION REQUIREMENTS

The BM77 module is labeled with its own NCC mark and certificate number as below:

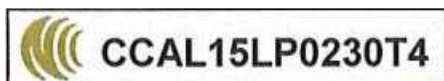

The user's manual should contain below warning (for RF device) in traditional Chinese:

注意！

依據 低功率電波輻射性電機管理辦法

第十二條 經型式認證合格之低功率射頻電機，非經許可，公司、商號或使用者均不得擅自變更頻率、加大功率或變更原設計之特性及功能。

第十四條 低功率射頻電機之使用不得影響飛航安全及干擾合法通信；經發現有干擾現象時，應立即停用，並改善至無干擾時方得繼續使用。前項合法通信，指依電信規定作業之無線電信。

低功率射頻電機須忍受合法通信或工業、科學及醫療用電波輻射性電機設備之干擾。

### 3.9.2 HELPFUL WEB SITES

National Communications Commission (NCC): <http://www.ncc.gov.tw>

### 3.10 Other Regulatory Jurisdictions

Should other regulatory jurisdiction certification be required by the customer, or the customer need to recertify the module for other reasons, a certification utility is available. For further regulatory Certification Utility and documentation, contact ISSC Technologies Corp.

## 4.0 ELECTRICAL CHARACTERISTICS

**TABLE 4-1: ENVIRONMENTAL CONDITIONS**

Parameter	Value
Temperature Range (Operating)	-20 to 70°C
Temperature Range (Storage)	-40 to 85°C
Relative Humidity (Operating)	10% to 90%
Relative Humidity (Storage)	10% to 90%
Moisture Sensitivity Level	2

**TABLE 4-2: ELECTRICAL CHARACTERISTICS**

Parameter	Min.	Typ.	Max.	Units
Supply Voltage (BAT_IN)	3.2		4.3	V
I/O Supply Voltage (VDD_IO)	2.8	3.3	3.63	V
<b>I/O Voltage Levels</b>				
V <sub>IL</sub> input logic levels low	-0.3		0.8	V
V <sub>IH</sub> input logic levels high	2.0		3.6	V
V <sub>OL</sub> output logic levels low			0.4	V
V <sub>OH</sub> output logic levels high	2.4			V
<b>RESET</b>				
V <sub>TH,res</sub> threshold voltage		1.6		V
<b>Input and Tri-State Current with</b>				
Pull-up Resistor		65		Kohm
Leakage current	-10		10	uA
<b>Supply Current</b>				
TX mode			70	mA
RX mode			70	mA

**TABLE 4-3: SUPPLY CONSUMPTION – CLASSIC <sup>(1)</sup>**

Parameter	Current (avg.)	Units	Notes
Standby mode	2.543	mA	
Deep power down mode	0.343	mA	
Connected + Sniff, Master (no data)	0.858	mA	No data was transmitted Sniff interval = 500ms
Connected + Sniff, Slave (no data)	0.864	mA	No data was transmitted Sniff interval = 500ms
Data, Master	23.03	mA	(Data transmitted at 115200 bps; block size=500)
Data, Slave	25.597	mA	(Data transmitted at 115200 bps; block size=500)

**Note 1:** Classic BR/EDR, RX\_IND Function Enabled



# BM77SPPx3MC2

**TABLE 4-4: SUPPLY CONSUMPTION –LOW ENERGY <sup>(1)</sup>**

Parameter	Current (avg.)	Units	Notes
Standby mode (Discoverable & Connectable mode)	1.237	mA	LE fast advertising interval = 160 ms, standby at 0 ~ 30 sec
Standby mode (Discoverable & Connectable mode)	0.765	mA	LE Reduced Power advertising interval = 961 ms, standby after 30 sec
Deep power down mode	0.348	mA	
Connected (No data), connection interval = 500ms	0.679	mA	No data was transmitted connection interval = 500 ms, latency=2.
Connected (transfer data), connection interval = 500ms	13.073	mA	Connection interval = 500 ms, latency=2.
Connected (No data), connection interval = 20ms	1.648	mA	No data was transmitted connection interval = 20 ms, latency=2.
Connected (transfer data), connection interval = 20ms	18.581	mA	Connection interval = 20 ms, latency=2.

**Note 1:** Low Energy, RX\_IND Function Enabled

**TABLE 4-5: UART BAUD**

Baud	Crystal Frequency (MHz)	Actual Baud	Error Rate (%)
921600	16	941176	2.12
460800	16	457143	-0.79
307200	16	307692	0.16
230400	16	231884	0.64
115200	16	117647	2.1
57600	16	57145	-0.97
38400	16	38462	0.16
28800	16	28623	-0.62
19200	16	19231	0.16
14400	16	14480	0.55
9600	16	9615	0.16
4800	16	4808	0.16
2400	16	2399	-0.03

## 4.0 ORDERING INFORMATION

**TABLE 4-1: ORDERING INFORMATION**

Part Number	Description
BM77SPPS3MC2-0007AA	Bluetooth® 4.0 Dual Mode, Class 2, Surface Mount module with integral antenna, with shield
BM77SPP03MC2-0007AA	Bluetooth® 4.0 Dual Mode, Class 2, Surface Mount module, external antenna, no shield
EV77SPPS3MC2A	Evaluation board for the BM77SPPS3MC2 Bluetooth Dual Mode module with USB cable

## APPENDIX A: REVISION HISTORY

### **Revision 2.0 (October 2014)**

Added content and editing.

### **Revision 2.1.1 (June 2015)**

Updated operating temperature range and Taiwan NCC certification information.

NOTES: