

**TOSHIBA**

**8 Bit Microcontroller  
TLCS-870/X Series**

**TMP88CS42NG**

Not Recommended  
for New Design

**TOSHIBA CORPORATION**

The information contained herein is subject to change without notice. 021023\_D

TOSHIBA is continually working to improve the quality and reliability of its products. Nevertheless, semiconductor devices in general can malfunction or fail due to their inherent electrical sensitivity and vulnerability to physical stress.

It is the responsibility of the buyer, when utilizing TOSHIBA products, to comply with the standards of safety in making a safe design for the entire system, and to avoid situations in which a malfunction or failure of such TOSHIBA products could cause loss of human life, bodily injury or damage to property.

In developing your designs, please ensure that TOSHIBA products are used within specified operating ranges as set forth in the most recent TOSHIBA products specifications.

Also, please keep in mind the precautions and conditions set forth in the "Handling Guide for Semiconductor Devices," or "TOSHIBA Semiconductor Reliability Handbook" etc. 021023\_A

The TOSHIBA products listed in this document are intended for usage in general electronics applications (computer, personal equipment, office equipment, measuring equipment, industrial robotics, domestic appliances, etc.).

These TOSHIBA products are neither intended nor warranted for usage in equipment that requires extraordinarily high quality and/or reliability or a malfunction or failure of which may cause loss of human life or bodily injury ("Unintended Usage"). Unintended Usage include atomic energy control instruments, airplane or spaceship instruments, transportation instruments, traffic signal instruments, combustion control instruments, medical instruments, all types of safety devices, etc. Unintended Usage of TOSHIBA products listed in this document shall be made at the customer's own risk. 021023\_B

The products described in this document shall not be used or embedded to any downstream products of which manufacture, use and/or sale are prohibited under any applicable laws and regulations. 060106\_Q

The information contained herein is presented only as a guide for the applications of our products. No responsibility is assumed by TOSHIBA for any infringements of patents or other rights of the third parties which may result from its use. No license is granted by implication or otherwise under any patents or other rights of TOSHIBA or the third parties. 070122\_C

The products described in this document are subject to foreign exchange and foreign trade control laws. 060925\_E

For a discussion of how the reliability of microcontrollers can be predicted, please refer to Section 1.3 of the chapter entitled Quality and Reliability Assurance/Handling Precautions. 030619\_S

## Revision History

Date	Revision	
2007/7/13	1	First Release
2008/2/25	2	Contents Revised
2008/9/30	3	Contents Revised

Not Recommended  
for New Design

## Caution in Setting the UART Noise Rejection Time

When UART is used, settings of RXDNC are limited depending on the transfer clock specified by BRG. The combination "O" is available but please do not select the combination "--".

The transfer clock generated by timer/counter interrupt is calculated by the following equation :

$$\text{Transfer clock [Hz]} = \text{Timer/counter source clock [Hz]} \div \text{TTREG set value}$$

BRG setting	Transfer clock [Hz]	RXDNC setting			
		00 (No noise rejection)	01 (Reject pulses shorter than $31/fc[s]$ as noise)	10 (Reject pulses shorter than $63/fc[s]$ as noise)	11 (Reject pulses shorter than $127/fc[s]$ as noise)
000	$fc/13$	O	O	O	-
110 (When the transfer clock generated by timer/counter interrupt is the same as the right side column)	$fc/8$	O	-	-	-
	$fc/16$	O	O	-	-
	$fc/32$	O	O	O	-
The setting except the above		O	O	O	O

Not Recommended for New Design

Not Recommended  
for New Design

# Table of Contents

---

---

## TMP88CS42NG

---

1.1	Features	1
1.2	Pin Assignment	3
1.3	Block Diagram	4
1.4	Pin Names and Functions	5

---

---

## 2. Functional Description

---

2.1	Functions of the CPU Core	9
2.1.1	Memory Address Map	9
2.1.2	Program Memory (ROM)	10
2.1.3	Data Memory (RAM)	10
2.1.4	System Clock Control Circuit	11
2.1.4.1	Clock Generator	
2.1.4.2	Timing Generator	
2.1.4.3	Standby Control Circuit	
2.1.4.4	Controlling Operation Modes	
2.1.5	Reset Circuit	23
2.1.5.1	External Reset Input	
2.1.5.2	Address Trap Reset	
2.1.5.3	Watchdog Timer Reset	
2.1.5.4	System Clock Reset	

---

---

## 3. Interrupt Control Circuit

---

3.1	Interrupt latches (IL38 to IL2)	26
3.2	Interrupt enable register (EIR)	27
3.2.1	Interrupt master enable flag (IMF)	27
3.2.2	Individual interrupt enable flags (EF38 to EF3)	27
3.3	Interrupt Sequence	30
3.3.1	Interrupt acceptance processing is packaged as follows	30
3.3.2	Saving/restoring general-purpose registers	31
3.3.2.1	Using Automatic register bank switching	
3.3.2.2	Using register bank switching	
3.3.2.3	Using PUSH and POP instructions	
3.3.2.4	Using data transfer instructions	
3.3.3	Interrupt return	33
3.4	Software Interrupt (INTSW)	34
3.4.1	Address error detection	34
3.4.2	Debugging	34
3.5	External Interrupts	35

---

---

## 4. Special Function Register

---

4.1	SFR	37
4.2	DBR	39

---

---

## 5. Input/Output Ports

---

5.1	Port P0 (P03 to P00)	45
5.2	Port P1 (P17 to P10)	46
5.3	Port P2 (P22 to P20)	47
5.4	Port P3 (P37 to P30)	48
5.5	Port P4 (P47 to P40)	49
5.6	Port P5 (P57 to P50)	50
5.7	Port P6 (P67 to P60)	51
5.8	Port P7 (P77 to P70)	53

---

## 6. Time Base Timer (TBT) and Divider Output (DVO)

---

6.1	Time Base Timer	55
6.2	Divider Output (DVO)	57

---

## 7. Watchdog Timer (WDT)

---

7.1	Watchdog Timer Configuration	59
7.2	Watchdog Timer Control	60
7.2.1	Malfunction Detection Methods Using the Watchdog Timer	60
7.2.2	Watchdog Timer Enable	61
7.2.3	Watchdog Timer Disable	62
7.2.4	Watchdog Timer Interrupt (INTWDT)	62
7.2.5	Watchdog Timer Reset	63

---

## 8. 16-Bit TimerCounter 1 (TC1)

---

8.1	Configuration	65
8.2	TimerCounter Control	66
8.3	Function	68
8.3.1	Timer mode	68
8.3.2	External Trigger Timer Mode	70
8.3.3	Event Counter Mode	72
8.3.4	Window Mode	73
8.3.5	Pulse Width Measurement Mode	74
8.3.6	Programmable Pulse Generate (PPG) Output Mode	77

---

## 9. 16-Bit Timer (CTC)

---

9.1	Configuration	81
9.2	Control	82
9.3	Function	85
9.3.1	Timer mode with software start	85
9.3.2	Timer mode with external trigger start	86
9.3.3	Event counter mode	87
9.3.4	Programmable Pulse Generate (PPG) output mode	88

---

---

---

## 10. 8-Bit TimerCounter 3 (TC3)

---

10.1	Configuration .....	95
10.2	TimerCounter Control .....	96
10.3	Function .....	97
10.3.1	Timer mode.....	97
Figure 10-3	.....	99
10.3.3	Capture Mode.....	100

---

---

## 11. 8-Bit TimerCounter 4 (TC4)

---

11.1	Configuration .....	101
11.2	TimerCounter Control .....	102
11.3	Function .....	103
11.3.1	Timer Mode.....	103
11.3.2	Event Counter Mode.....	103
11.3.3	Programmable Divider Output (PDO) Mode.....	103
11.3.4	Pulse Width Modulation (PWM) Output Mode.....	104

---

---

## 12. 8-Bit TimerCounter 5,6(TC5, 6)

---

12.1	Configuration .....	107
12.2	TimerCounter Control .....	108
12.3	Function .....	112
12.3.1	8-Bit Timer Mode (TC5 and 6).....	112
12.3.2	8-Bit Event Counter Mode (TC5, 6).....	113
12.3.3	8-Bit Programmable Divider Output (PDO) Mode (TC5, 6).....	113
12.3.4	8-Bit Pulse Width Modulation (PWM) Output Mode (TC5, 6).....	115
12.3.5	16-Bit Timer Mode (TC5 and 6).....	117
12.3.6	16-Bit Event Counter Mode (TC5 and 6).....	118
12.3.7	16-Bit Pulse Width Modulation (PWM) Output Mode (TC5 and 6).....	118
12.3.8	16-Bit Programmable Pulse Generate (PPG) Output Mode (TC5 and 6).....	121

---

---

## 13. Motor Control Circuit (PMD: Programmable motor driver)

---

13.1	Outline of Motor Control .....	124
13.2	Configuration of the Motor Control Circuit .....	126
13.3	Position Detection Unit .....	127
13.3.1	Configuration of the position detection unit.....	128
13.3.2	Position Detection Circuit Register Functions.....	129
13.3.3	Outline Processing in the Position Detection Unit .....	132
13.4	Timer Unit .....	133
13.4.1	Configuration of the Timer Unit.....	134
13.4.1.1	Timer Circuit Register Functions	
13.4.1.2	Outline Processing in the Timer Unit	
13.5	Three-phase PWM Output Unit .....	138
13.5.1	Configuration of the three-phase PWM output unit.....	138
13.5.1.1	Pulse width modulation circuit (PWM waveform generating unit)	
13.5.1.2	Commutation control circuit	
13.5.2	Register Functions of the Waveform Synthesis Circuit.....	142
13.5.3	Port output as set with UOC/VOC/WOC bits and UPWM/VPWM/WPWM bits.....	144
13.5.4	Protective Circuit.....	146
13.5.5	Functions of Protective Circuit Registers .....	148
13.6	Electrical Angle Timer and Waveform Arithmetic Circuit .....	150



13.6.1	Electrical Angle Timer and Waveform Arithmetic Circuit .....	151
13.6.1.1	Functions of the Electrical Angle Timer and Waveform Arithmetic Circuit Registers	
13.6.1.2	List of PMD Related Control Registers	

---

## 14. Asynchronous Serial interface (UART)

---

14.1	Configuration .....	163
14.2	Control .....	164
14.3	Transfer Data Format .....	166
14.4	Transfer Rate .....	167
14.5	Data Sampling Method .....	167
14.6	STOP Bit Length .....	168
14.7	Parity .....	168
14.8	Transmit/Receive Operation .....	168
14.8.1	Data Transmit Operation .....	168
14.8.2	Data Receive Operation .....	168
14.9	Status Flag .....	169
14.9.1	Parity Error .....	169
14.9.2	Framing Error .....	169
14.9.3	Overrun Error .....	169
14.9.4	Receive Data Buffer Full .....	170
14.9.5	Transmit Data Buffer Empty .....	170
14.9.6	Transmit End Flag .....	171

---

## 15. Synchronous Serial Interface (SIO)

---

15.1	Configuration .....	173
15.2	Control .....	174
15.3	Serial clock .....	175
15.3.1	Clock source .....	175
15.3.1.1	Internal clock	
15.3.1.2	External clock	
15.3.2	Shift edge .....	177
15.3.2.1	Leading edge	
15.3.2.2	Trailing edge	
15.4	Number of bits to transfer .....	177
15.5	Number of words to transfer .....	177
15.6	Transfer Mode .....	178
15.6.1	4-bit and 8-bit transfer modes .....	178
15.6.2	4-bit and 8-bit receive modes .....	180
15.6.3	8-bit transfer / receive mode .....	181

---

## 16. 10-bit AD Converter (ADC)

---

16.1	Configuration .....	183
16.2	Register configuration .....	184
16.3	Function .....	187
16.3.1	Software Start Mode .....	187
16.3.2	Repeat Mode .....	187
16.3.3	Register Setting .....	188
Example :	.....	189
16.4	STOP mode during AD Conversion .....	189
16.5	Analog Input Voltage and AD Conversion Result .....	190
16.6	Precautions about AD Converter .....	191

16.6.1	Analog input pin voltage range .....	191
16.6.2	Analog input shared pins .....	191
16.6.3	Noise Countermeasure .....	191

---



---

## 17. 8-Bit High-speed PWM (HPWM0 and HPWM1)

---

17.1	Configuration .....	193
17.2	Control .....	194
17.3	Functional Description .....	194
17.3.1	Operation modes .....	194
17.3.1.1	8-bit mode .....	
17.3.1.2	7-bit mode .....	
17.3.1.3	6-bit mode .....	
17.3.2	Setting output data .....	197

---



---

## 18. Input/Output Circuitry

---

18.1	Control pins .....	199
18.2	Input/output ports .....	200

---



---

## 19. Electrical Characteristics

---

19.1	Absolute Maximum Ratings .....	201
19.2	Operating Conditions .....	202
19.3	DC Characteristics .....	202
19.4	AD Conversion Characteristics .....	203
19.5	AC Characteristics .....	203
19.5	.....	203
19.5	.....	203
19.6	Recommended Oscillation Conditions .....	204
19.7	Handling Precaution .....	204

---



---

## 20. Package Dimensions

---

This is a technical document that describes the operating functions and electrical specifications of the 8-bit microcontroller series TLCS-870/X (LSI).

---

Not Recommended  
for New Design

## CMOS 8-Bit Microcontroller

# TMP88CS42NG

Product No.	ROM (MaskROM)	RAM	Package	OTP MCU
TMP88CS42NG	65536 bytes	2176 bytes	SDIP64-P-750-1.78	TMP88PS42NG

### 1.1 Features

- 8-bit single chip microcomputer TLCS-870/X series
  - Instruction execution time :
    - 0.20  $\mu$ s (at 20 MHz)
  - 181 types & 842 basic instructions
- 35 interrupt sources (External : 6 Internal : 29)
- Input / Output ports (55 pins)
  - Large current output: 24pins (Typ. 20mA), LED direct drive
- Prescaler
  - Time base timer
    - Divider output function (DVO)
- Watchdog Timer
  - Select of "internal reset request" or "interrupt request".
- 16-bit timer counter: 1 ch
  - Timer, External trigger, Window, Pulse width measurement, Event counter, Programmable pulse generate (PPG) modes
- 16-bit timer/counter(CTC): 1ch
  - CTC/Timer, event counter or PPG (Programmable Pulse) output
- 8-bit timer counter : 1 ch
  - Timer, Event counter, Capture modes
- 8-bit timer counter : 1 ch

- The information contained herein is subject to change without notice. 021023\_D
- TOSHIBA is continually working to improve the quality and reliability of its products. Nevertheless, semiconductor devices in general can malfunction or fail due to their inherent electrical sensitivity and vulnerability to physical stress. It is the responsibility of the buyer, when utilizing TOSHIBA products, to comply with the standards of safety in making a safe design for the entire system, and to avoid situations in which a malfunction or failure of such TOSHIBA products could cause loss of human life, bodily injury or damage to property. In developing your designs, please ensure that TOSHIBA products are used within specified operating ranges as set forth in the most recent TOSHIBA products specifications. Also, please keep in mind the precautions and conditions set forth in the "Handling Guide for Semiconductor Devices," or "TOSHIBA Semiconductor Reliability Handbook" etc. 021023\_A
- The TOSHIBA products listed in this document are intended for usage in general electronics applications (computer, personal equipment, office equipment, measuring equipment, industrial robotics, domestic appliances, etc.). These TOSHIBA products are neither intended nor warranted for usage in equipment that requires extraordinarily high quality and/or reliability or a malfunction or failure of which may cause loss of human life or bodily injury ("Unintended Usage"). Unintended Usage include atomic energy control instruments, airplane or spaceship instruments, transportation instruments, traffic signal instruments, combustion control instruments, medical instruments, all types of safety devices, etc. Unintended Usage of TOSHIBA products listed in this document shall be made at the customer's own risk. 021023\_B
- The products described in this document shall not be used or embedded to any downstream products of which manufacture, use and/or sale are prohibited under any applicable laws and regulations. 060106\_Q
- The information contained herein is presented only as a guide for the applications of our products. No responsibility is assumed by TOSHIBA for any infringements of patents or other rights of the third parties which may result from its use. No license is granted by implication or otherwise under any patents or other rights of TOSHIBA or the third parties. 070122\_C
- The products described in this document are subject to foreign exchange and foreign trade control laws. 060925\_E
- For a discussion of how the reliability of microcontrollers can be predicted, please refer to Section 1.3 of the chapter entitled Quality and Reliability Assurance/Handling Precautions. 030619\_S

- Timer, Event counter, Pulse width modulation (PWM) output,  
Programmable divider output (PDO) modes
10. 8-bit timer counter : 2 ch
- Timer, Event counter, Programmable divider output (PDO),  
Pulse width modulation (PWM) output,  
Programmable pulse generation (PPG) modes
11. Programmable motor driver (PMD) : 2 ch
- Sine wave drive circuit (built-in sine wave data-table RAM)  
Rotor position detect function  
Motor control timer and capture function  
Overload protective function  
Auto commutation and auto position detection start function
12. 8-bit UART : 1 ch
13. 8-bit SIO: 1 ch
14. 10-bit successive approximation type AD converter
- Analog input: 16 ch
15. 8-bit High-speed PWM (HPWM0 and HPWM1)
16. Clock oscillation circuit : 1 set
17. Low power consumption operation (2 modes)
- STOP mode: Oscillation stops. (Battery/Capacitor back-up.)
  - IDLE mode: CPU stops.  
Only peripherals operate using high frequency clock. Release by interrupts (CPU restarts).
18. Operation voltage:
- 4.5 V to 5.5 V at 20MHz

1.2 Pin Assignment

(U2) P52	1	64	P51 (EMG2)
(V2) P53	2	63	P50 (CL2)
(W2) P54	3	62	P17 (PDW2)
(X2) P55	4	61	P16 (PDV2)
(Y2) P56	5	60	P15 (PDU2)
(Z2) P57	6	59	P14 (PPG1/PWM5/PDQ5)
VSS	7	58	P13 (TC5/DV0)
XIN	8	57	P12 (INT2/TC1)
XOUT	9	56	P11 (INT1)
TEST	10	55	P10 (INT0)
VDD	11	54	P03 (HPWM4)
(TC3/INT3)P21	12	53	P02 (HPWM0)
(PWM4/PDQ4/TC4/INT4)P22	13	52	P01 (TXD2/PDQ6/RWM6/PPG6)
RESET	14	51	P00 (RXD2/TC6)
(STOP/INT5) P20	15	50	AVSS
(Z1) P30	16	49	AVDD
(Y1)P31	17	48	VAREF
(X1) P32	18	47	P77 (AIN15/DBOUT2)
(W1) P33	19	46	P76 (AIN14)
(V1) P34	20	45	P75 (AIN13)
(U1) P35	21	44	P74 (AIN12)
(EMG1) P36	22	43	P73 (AIN11)
(CL1) P37	23	42	P72 (AIN10)
(PDW1) P40	24	41	P71 (AIN9)
(PDV1) P41	25	40	P70 (AIN8)
(PDU1) P42	26	39	P67 (AIN7/DBOUT1)
(SCK) P43	27	38	P66 (AIN6)
(SI/RXD1) P44	28	37	P65 (AIN5)
(SO/TXD1) P45	29	36	P64 (AIN4)
(PPG2) P46	30	35	P63 (AIN3)
(CTC) P47	31	34	P62 (AIN2)
(AIN0) P60	32	33	P61 (AIN1)

Figure 1-1 Pin Assignment

### 1.3 Block Diagram

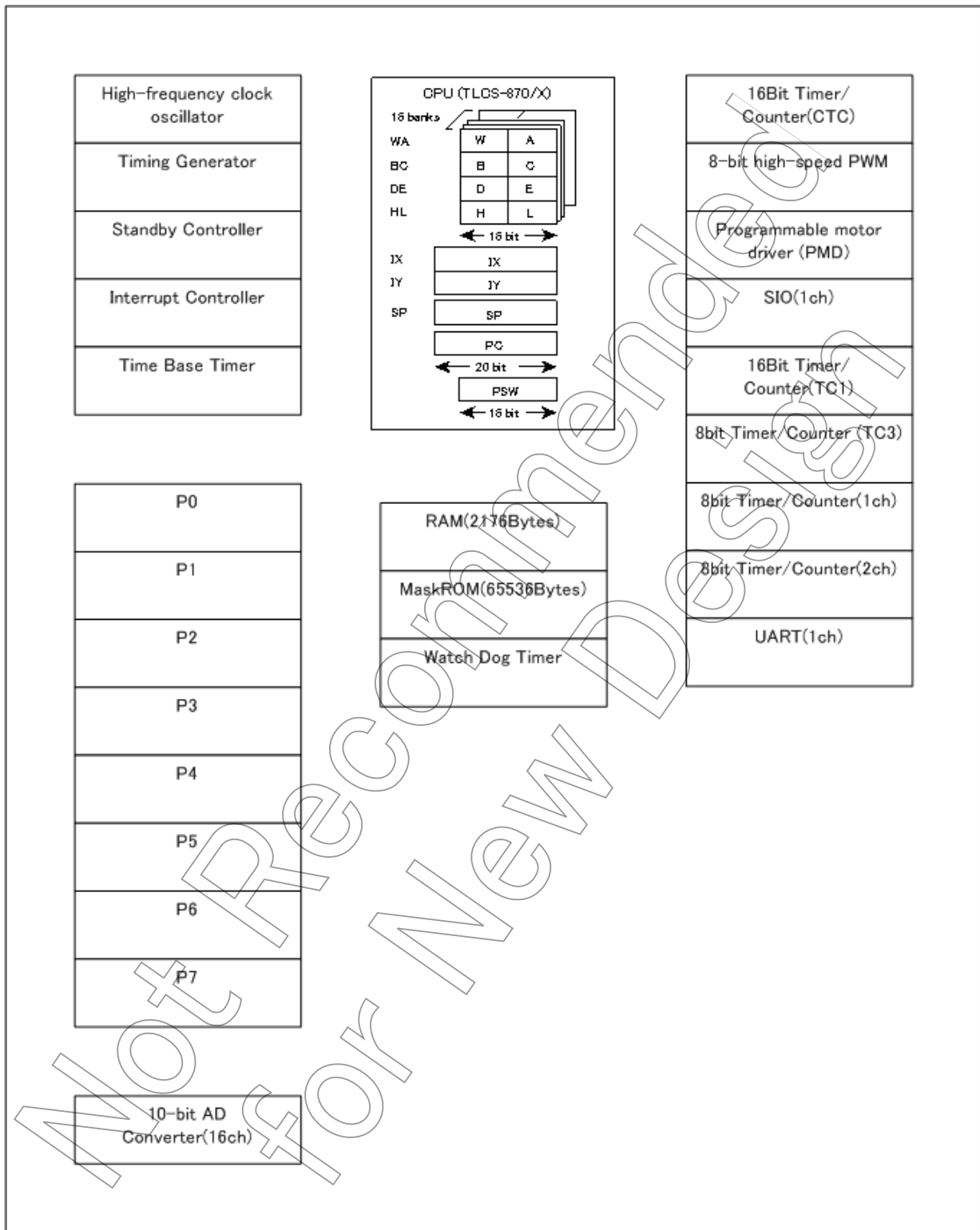

Figure 1-2 Block Diagram

## 1.4 Pin Names and Functions

Table 1-1 Pin Names and Functions(1/3)

Pin Name	Pin Number	Input/Output	Functions
P03 HPWM1	54	IO O	PORT03 High-speed PWM1 output
P02 HPWM0	53	IO O	PORT02 High-speed PWM0 output
P01 TXD2 PDO6/PWM6/PPG6	52	IO O O	PORT01 UART data output 2 PDO6/PWM6/PPG6 output
P00 RXD2 TC6	51	IO I I	PORT00 UART data input 2 TC6 input
P17 PDW2	62	IO I	PORT17 PMD control input W2
P16 PDV2	61	IO I	PORT16 PMD control input V2
P15 PDU2	60	IO I	PORT15 PMD control input U2
P14 PPG1 PWM5/PDO5	59	IO O O	PORT14 PPG1 output PWM5/PDO5 output
P13 TC5 DVO	58	IO I O	PORT13 TC5 input Divider Output
P12 INT2 TC1	57	IO I I	PORT12 External interrupt 2 input TC1 input
P11 INT1	56	IO I	PORT11 External interrupt 1 input
P10 INT0	55	IO I	PORT10 External interrupt 0 input
P22 INT4 TC4 PWM4/PDO4	13	IO I I O	PORT22 External interrupt 4 input TC4 input PWM4/PDO4 output
P21 INT3 TC3	12	IO I I	PORT21 External interrupt 3 input TC3 pin input
P20 INT5 STOP	15	IO I I	PORT20 External interrupt 5 input STOP mode release signal input
P37 CL1	23	IO I	PORT37 PMD over load protection input1
P36 EMG1	22	IO I	PORT36 PMD emergency stop input1
P35 U1	21	IO O	PORT35 PMD control output U1



Table 1-1 Pin Names and Functions(2/3)

Pin Name	Pin Number	Input/Output	Functions
P34 V1	20	IO O	PORT34 PMD control output V1
P33 W1	19	IO O	PORT33 PMD control output W1
P32 X1	18	IO O	PORT32 PMD control output X1
P31 Y1	17	IO O	PORT31 PMD control output Y1
P30 Z1	16	IO O	PORT30 PMD control output Z1
P47 CTC	31	IO I	PORT47 CTC input
P46 PPG2	30	IO O	PORT46 PPG2 output
P45 TXD1 SO	29	IO O O	PORT45 UART data output 1 Serial Data Output
P44 RXD1 SI	28	IO I I	PORT44 UART data input 1 Serial Data Input
P43 SCK	27	IO IO	PORT43 Serial Clock I/O
P42 PDU1	26	IO I	PORT42 PMD control input U1
P41 PDV1	25	IO I	PORT41 PMD control input V1
P40 PDW1	24	IO I	PORT40 PMD control input W1
P57 Z2	6	IO O	PORT57 PMD control output Z2
P56 Y2	5	IO O	PORT56 PMD control output Y2
P55 X2	4	IO O	PORT55 PMD control output X2
P54 W2	3	IO O	PORT54 PMD control output W2
P53 V2	2	IO O	PORT53 PMD control output V2
P52 U2	1	IO O	PORT52 PMD control output U2
P51 EMG2	64	IO I	PORT51 PMD emergency stop input2
P50 CL2	63	IO I	PORT50 PMD over load protection input2
P67 AIN7 DBOUT1	39	IO I O	PORT67 Analog Input7 PMD debug output1

Table 1-1 Pin Names and Functions(3/3)

Pin Name	Pin Number	Input/Output	Functions
P66 AIN6	38	IO I	PORT66 Analog Input6
P65 AIN5	37	IO I	PORT65 Analog Input5
P64 AIN4	36	IO I	PORT64 Analog Input4
P63 AIN3	35	IO I	PORT63 Analog Input3
P62 AIN2	34	IO I	PORT62 Analog Input2
P61 AIN1	33	IO I	PORT61 Analog Input1
P60 AIN0	32	IO I	PORT60 Analog Input0
P77 AIN15 DBOUT2	47	IO I O	PORT77 Analog Input15 PMD debug output2
P76 AIN14	46	IO I	PORT76 Analog Input14
P75 AIN13	45	IO I	PORT75 Analog Input13
P74 AIN12	44	IO I	PORT74 Analog Input12
P73 AIN11	43	IO I	PORT73 Analog Input11
P72 AIN10	42	IO I	PORT72 Analog Input10
P71 AIN9	41	IO I	PORT71 Analog Input9
P70 AIN8	40	IO I	PORT70 Analog Input8
XIN	8	I	Resonator connecting pins for high-frequency clock
XOUT	9	O	Resonator connecting pins for high-frequency clock
RESET	14	I	Reset signal
TEST	10	I	Test pin for out-going test and the Serial PROM mode control pin. Usually fix to low level. Fix to high level when the Serial PROM mode starts.
VAREF	48	I	Analog Base Voltage Input Pin for A/D Conversion
AVDD	49	I	Analog Power Supply
AVSS	50	I	Analog Power Supply
VDD	11	I	+5V
VSS	7	I	0(GND)

Not Recommended  
for New Design

## 2. Functional Description

### 2.1 Functions of the CPU Core

The CPU core consists mainly of the CPU, system clock control circuit, and interrupt control circuit.

This chapter describes the CPU core, program memory, data memory, and reset circuit of the TMP88CS42NG.

#### 2.1.1 Memory Address Map

The memory of the TMP88CS42NG consists of four blocks: ROM, RAM, SFR (Special Function Registers), and DBR (Data Buffer Registers), which are mapped into one 1-Mbyte address space. The general-purpose registers consist of 16 banks, which are mapped into the RAM-address space. Figure 2-1 shows a memory address map of the TMP88CS42NG.

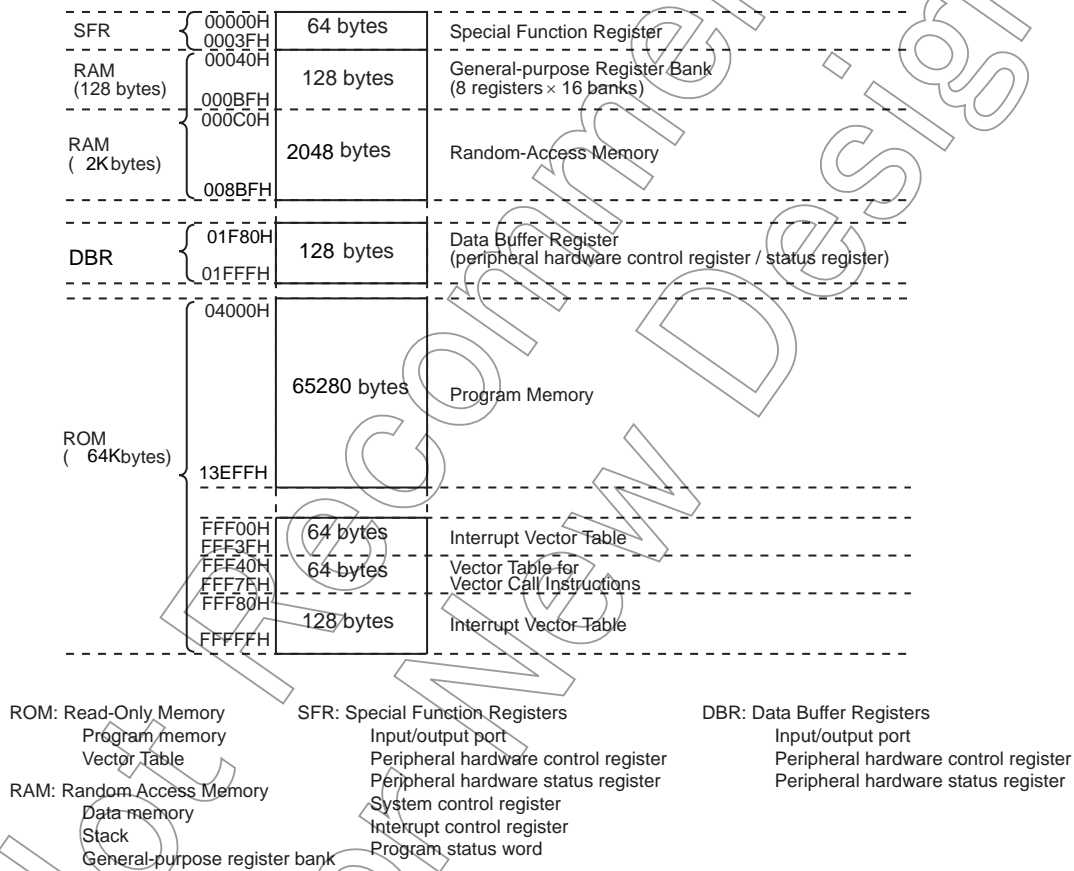

Figure 2-1 Memory address map

### 2.1.2 Program Memory (ROM)

The TMP88CS42NG contains 64Kbytes program memory (MaskROM) located at addresses 04000H to 13EFFH and addresses FFF00H to FFFFFH.

### 2.1.3 Data Memory (RAM)

The TMP88CS42NG contains 2Kbytes +128bytes RAM. The first 128bytes location (00040H to 000BFH) of the internal RAM is shared with a general-purpose register bank.

The content of the data memory is indeterminate at power-on, so be sure to initialize it in the initialize routine.

Example :Clearing the internal RAM of the TMP88CS42NG (clear all RAM addresses to 0, except bank 0)

```
LD      HL, 0048H      ; Set the start address
LD      A, 00H         ; Set the initialization data (00H)
LD      BC, 877H       ; Set byte counts (-1)
SRAMCLR: LD      (HL+), A
DEC     BC
JRS     F, SRAMCLR
```

Note: Because general-purpose registers exist in the RAM, never clear the current bank address of RAM. In the above example, the RAM is cleared except bank 0.

Not Recommended for New Design

### 2.1.4 System Clock Control Circuit

The System Clock Control Circuit consists of a clock generator, timing generator, and standby control circuit.

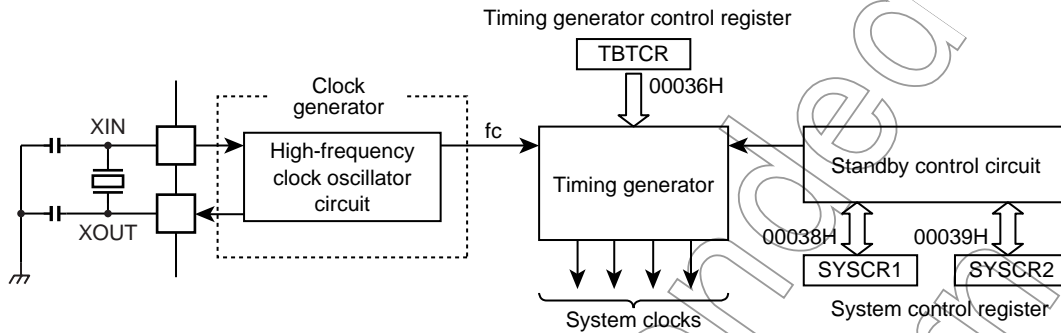

Figure 2-2 System Clock Control Circuit

#### 2.1.4.1 Clock Generator

The Clock Generator generates the fundamental clock which serves as the reference for the system clocks supplied to the CPU core and peripheral hardware units.

The high-frequency clock (frequency  $f_c$ ) can be obtained easily by connecting a resonator to the XIN and XOUT pins. Or a clock generated by an external oscillator can also be used. In this case, enter the external clock from the XIN pin and leave the XOUT pin open. The TMP88CS42NG does not support the CR network that produces a time constant.

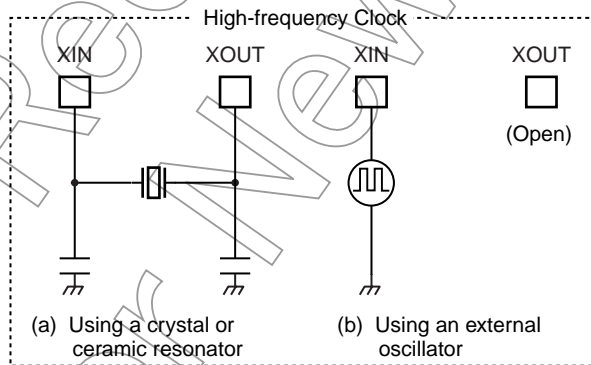

Figure 2-3 Example for Connecting a Resonator

#### Adjusting the oscillation frequency

Note: Although no hardware functions are provided that allow the fundamental clock to be monitored directly from the outside, the oscillation frequency can be adjusted by forwarding the pulse of a fixed frequency (e.g., clock output) to a port and monitoring it in a program while interrupts and the watchdog timer are disabled. For systems that require adjusting the oscillation frequency, an adjustment program must be created beforehand.

#### 2.1.4.2 Timing Generator

The Timing Generator generates various system clocks from the fundamental clock that are supplied to the CPU core and peripheral hardware units. The Timing Generator has the following functions:

1. Generate a divider output ( $\overline{DVO}$ ) pulse
2. Generate the source clock for the time base timer
3. Generate the source clock for the watchdog timer
4. Generate the internal source clock for the timer counter
5. Generate a warm-up clock when exiting STOP mode

(1) Configuration of the Timing Generator

The Timing Generator a 3-stage prescaler, 21-stage dividers, and a machine cycle counter.

When reset and when entering/exiting STOP mode, the prescaler and dividers are cleared to 0.

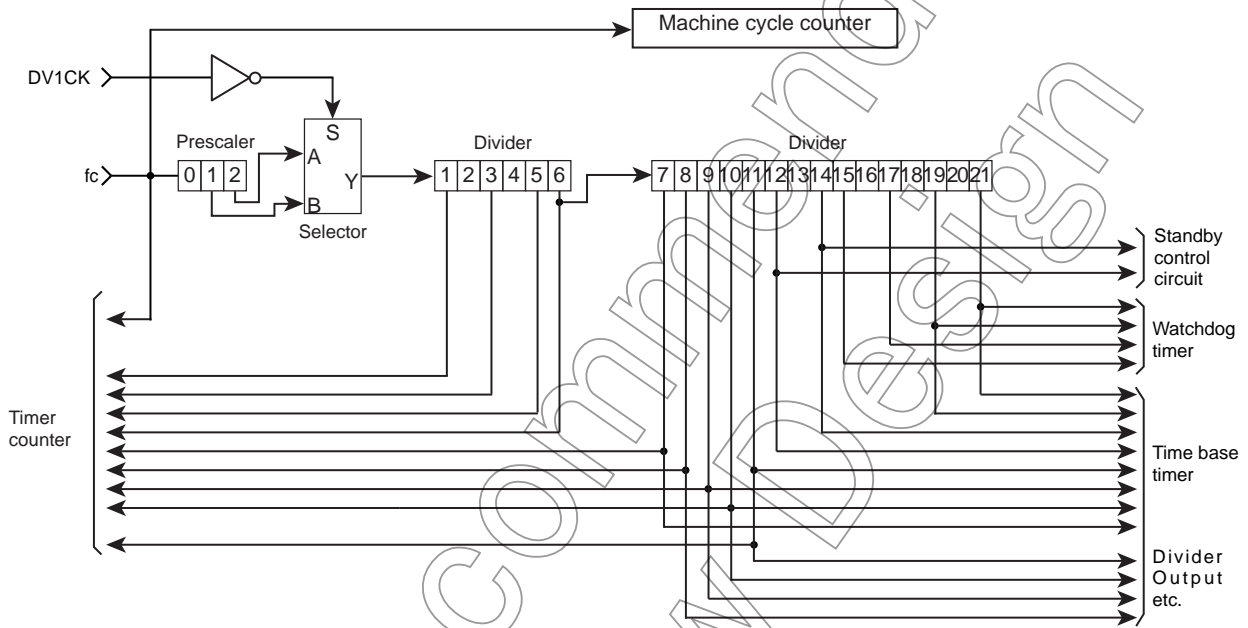

Figure 2-4 Configuration of the Timing Generator

Divider Control Register

CGCR (0030H)	7	6	5	4	3	2	1	0	(Initial value: 000* *000)
	0	0	DV1CK			0	0	0	

DV1CK	Selects input clock to the first divider stage	0: fc/4 1: fc/8	R/W
-------	--	--------------------	-----

Note 1: fc: the high-frequency clock [Hz], \*: Don't care

Note 2: The CGCR Register bits 4 and 3 show an indeterminate value when read.

Note 3: Be sure to write "0" to CGCR Register bits 7, 6, 2, 1 and 0.

Timing Generator Control Register

TBTCR (0036H)	7	6	5	4	3	2	1	0	(Initial value: 0000 0000)
	DVOEN	DVOCK	0	TBTEN			TBTCK		

Note 1: \*: Don't care

Note 2: Be sure to write "0" to TBTCR Register bit 4.

(2) Machine cycle

Instruction execution and the internal hardware operations are synchronized to the system clocks.

The minimum unit of instruction execution is referred to as the "machine cycle". The TLCS-870/X series has 15 types of instructions, from 1-cycle instructions which are executed in one machine cycle up to 15-cycle instructions that require a maximum of 15 machine cycles.

A machine cycle consists of four states (S0 to S3), with each state comprised of one main system clock cycle.

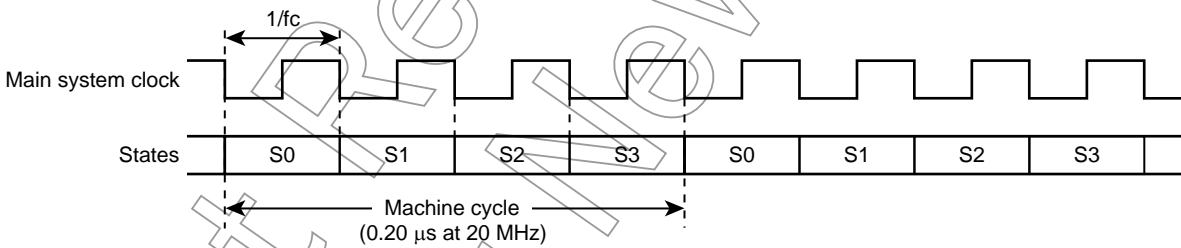

Figure 2-5 Machine Cycles



### 2.1.4.3 Standby Control Circuit

The Standby Control Circuit starts/stops the high-frequency clock oscillator circuit and selects the main system clock. The System Control Registers (SYSCR1, SYSCR2) are used to control operation modes of this circuit. Figure 2-6 shows an operation mode transition diagram, followed by description of the System Control Registers.

#### (1) Single clock mode

Only the high-frequency clock oscillator circuit is used. Because the main system clock is generated from the high-frequency clock, the machine cycle time in single clock mode is  $4/f_c$  [s].

##### 1. NORMAL mode

In this mode, the CPU core and peripheral hardware units are operated with the high-frequency clock. The TMP88CS42NG enters this NORMAL mode after reset.

##### 2. IDLE mode

In this mode, the CPU and watchdog timer are turned off while the peripheral hardware units are operated with the high-frequency clock. IDLE mode is entered into by using System Control Register 2. The device is placed out of this mode and back into NORMAL mode by an interrupt from the peripheral hardware or an external interrupt. When IMF (interrupt master enable flag) = 1 (interrupt enabled), the device returns to normal operation after the interrupt has been serviced. When IMF = 0 (interrupt disabled), the device restarts execution beginning with the instruction next to one that placed it in IDLE mode.

##### 3. STOP mode

The entire system operation including the oscillator circuit is halted, retaining the internal state immediately before being stopped, with a minimal amount of power consumed.

STOP mode is entered into by using System Control Register 1, and is exited by  $\overline{STOP}$  pin input (level or edge selectable). After an elapse of the warm-up time, the device restarts execution beginning with the instruction next to one that placed it in STOP mode.

Table 2-1 Single Clock Mode

Operation Mode		Oscillator Circuit		CPU Core	Peripheral Circuit	Machine Cycle Time
		High Frequency	Low Frequency			
Single Clock	RESET	Oscillate	-	Reset	Reset	4/fc [s]
	NORMAL			Operate	Operate	
	IDLE			Stop		
	STOP				Stop	

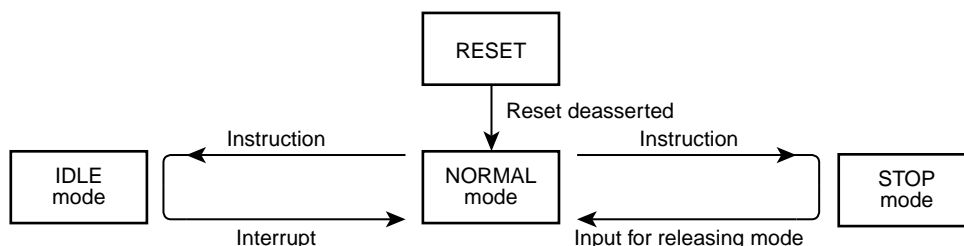

Figure 2-6 Operation Mode Transition Diagram

**System Control Register 1**

SYSCR1 (0038H)	7	6	5	4	3	2	1	0	(Initial value: 0000 00**)
	STOP	RELM	RETM	OUTEN	WUT				

STOP	Place the device in STOP mode	0: Keep the CPU core and peripheral hardware operating 1: Stop the CPU core and peripheral hardware (placed in STOP mode)		R/W
RELM	Select method by which the device is released from STOP mode	0: Released by a rising edge on STOP pin input 1: Released by a high level on STOP pin input		
RETM	Select operation mode after exiting STOP mode	0: Returns to NORMAL mode 1: Reserved		
OUTEN	Select port output state during STOP mode	0: High-impedance state 1: Hold output		
WUT	Unit of warm-up time when exiting STOP mode	When Returning to NORMAL Mode		
			DV1CK = 0	DV1CK = 1
		00	$3 \times 2^{16}/fc$	$3 \times 2^{17}/fc$
		01	$2^{16}/fc$	$2^{17}/fc$
		10	$2^{14}/fc$	$2^{15}/fc$
	11	Reserved	Reserved	

- Note 1: When entering from NORMAL mode into STOP mode, always be sure to set SYSCR1<RETM> to 0.
- Note 2: When the device is released from STOP mode by RESET pin input, it always returns to NORMAL mode regardless of how SYSCR1<RETM> is set.
- Note 3: fc: High-frequency clock [Hz], \*: Don't care
- Note 4: The values of the SYSCR1 Register bits 1 and 0 are indeterminate when read.
- Note 5: When placed the device in STOP mode, make sure to set "1" to SYSCR1<OUTEN>.
- Note 6: Releasing the device from the STOP mode causes the STOP bit to be automatically cleared to "0".
- Note 7: Select an appropriate value for the warm-up time according to the characteristic of the resonator used.

**System Control Register 2**

SYSCR2 (0039H)	7	6	5	4	3	2	1	0	(Initial value: 1000 ****)
	XEN	0	SYSCK	IDLE					

XEN	Control high-frequency oscillator	0: Stop oscillation 1: Continue or start oscillating	R/W
SYSCK	Select (write)/monitor (read) system clock	0: High-frequency clock (NORMAL/IDLE) 1: Reserved	R/W
IDLE	Place the device in IDLE mode	0: Keep the CPU and WDT operating 1: Stop the CPU and WDT (IDLE mode entered)	R/W

RETM	Operation Mode after Releasing STOP Mode	XEN	SYSCK
0	NORMAL mode	1	0
1	No operation	0	1

- Note 1: When exiting STOP mode, SYSCR2<XEN and SYSCK> are automatically rewritten according to SYSCR1<RETM>..
- Note 2: When SYSCR2<XEN>is cleared to 0, the device is reset.
- Note 3: WDT: Watchdog Timer, \*: Don't care
- Note 4: Be sure to write "0" to SYSCR2 Register bit6.
- Note 5: The values of the SYSCR2 Register bits 3 to 0 are indeterminate when read.
- Note 6: Change the operation mode after disabling external interrupts. If interrupts are enabled after changing operation mode, clear interrupt latches as appropriate in advance.

### 2.1.4.4 Controlling Operation Modes

#### (1) STOP mode

STOP mode is controlled by System Control Register 1 (SYSCR1) and the  $\overline{\text{STOP}}$  pin input. The  $\overline{\text{STOP}}$  pin is shared with P20 port and  $\overline{\text{INT5}}$  (external interrupt input 5). STOP mode is entered into by setting STOP (SYSCR1 Register bit 7) to 1. During STOP mode, the device retains the following state.

1. Stop oscillation, thereby stopping operation of all internal circuits.
2. The data memory, register, program status word, and port output latch hold the state in which they were immediately before entering STOP mode.
3. Clear the prescaler and divider for the timing generator to 0.
4. The program counter holds the instruction address two instructions ahead the one that placed the device in STOP mode (e.g., "SET (SYSCR1).7").

The device is released from STOP mode by the active level or edge on  $\overline{\text{STOP}}$  pin input as selected by SYSCR1<RELM>.

Note: Before entering STOP mode, be sure to disable interrupts. This is because if the signal on an external interrupt pin changes state during STOP (from entering STOP mode till completion of warm-up) the interrupt latch is set to 1, so that the device may accept the interrupt immediately after exiting STOP mode. Also, when reenabling interrupts after exiting STOP mode, be sure to clear the unnecessary interrupt latches beforehand.

##### a. Released by level (when RELM = 1)

The device is released from STOP mode by a high level on  $\overline{\text{STOP}}$  pin input.

Any instruction to place the device in STOP mode is ignored when executed while  $\overline{\text{STOP}}$  pin input level is high, and the device immediately goes to a release sequence (warm-up) without entering STOP mode. Therefore, before STOP mode can be entered while RELM = 1, the  $\overline{\text{STOP}}$  pin input must be verified to be low in a program. There are following methods to do this verification.

1. Testing the port status
2. INT5 interrupt (interrupt generated at a falling edge on  $\overline{\text{INT5}}$  pin input)

#### Example 1 :Entering STOP mode from NORMAL mode by testing P20 port

```

LD      (SYSCR1), 01010000B    ; Select to be released from STOP mode by level
SSTOPH : TEST    (P2DR) . 0      ; Wait until  $\overline{\text{STOP}}$  pin input goes low
        JRS     F, SSTOPH
        DI      ; IMF ← 0
        SET    (SYSCR1) . 7      ; Place the device in STOP mode
    
```

#### Example 2 :Entering STOP mode from NORMAL mode by INT5 interrupt

```

PINT5 : TEST    (P2DR) . 0      ; Do not enter STOP mode if P20 port input level is
                                ; high, to eliminate noise
        JRS     F, SINT5        ; Do not enter STOP mode if P20 port input level is
                                ; high, to eliminate noise
        LD      (SYSCR1), 01010000B ; Select to be released from STOP mode by level
        DI      ; IMF ← 0
        SET    (SYSCR1) . 7      ; Place the device in STOP mode
SINT5 : RETI
    
```

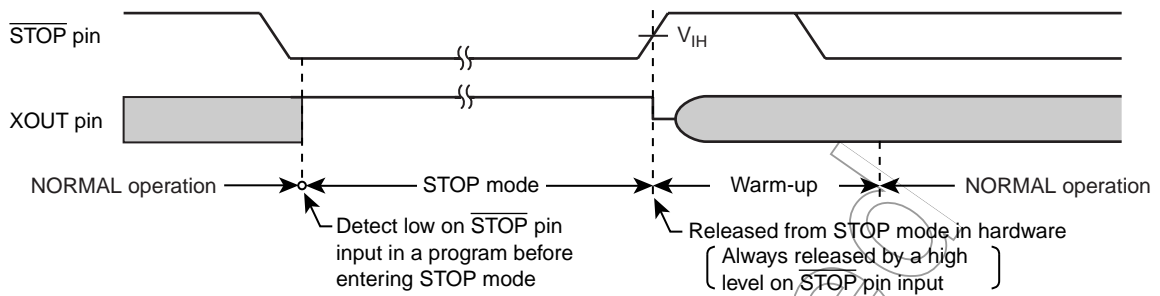

Figure 2-7 Released from STOP Mode by Level

Note 1: Once warm-up starts, the device does not return to STOP mode even when the  $\overline{\text{STOP}}$  pin input is pulled low again.

Note 2: If RELM is changed to 1 (level mode) after being set to 0 (edge mode), STOP mode remains unchanged unless a rising edge on  $\overline{\text{STOP}}$  pin input is detected.

a. Released by edge (when RELM = 0)

The device is released from STOP mode by a rising edge on  $\overline{\text{STOP}}$  pin input. This method is used in applications where a relatively short time of program processing is repeated at certain fixed intervals. Apply a fixed-period signal (e.g., clock from the low-power oscillating source) to the  $\overline{\text{STOP}}$  pin. When RELM = 0 (edge mode), the device is placed in STOP mode even when the  $\overline{\text{STOP}}$  pin input level is high.

Example :Entering STOP mode from NORMAL mode

```
DI          ; IMF ← 0
LD (SYSCR1), 10010000B ; Set to be released by edge when entering STOP mode
```

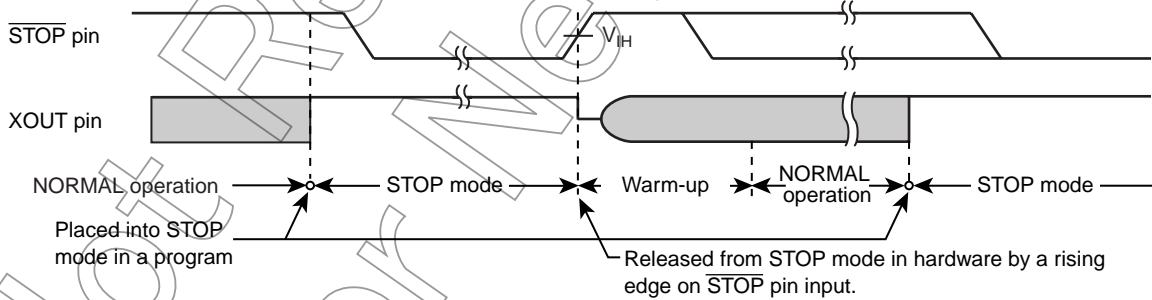

Figure 2-8 Released from STOP Mode by Edge

The device is released from STOP mode following the sequence described below.

1. Only the high-frequency oscillator is oscillating.
2. A warm-up time is inserted in order to allow for the clock oscillation to stabilize. During warm-up, the internal circuits remain idle. The warm-up time can be selected from three choices according to the oscillator characteristics by using SYSCR1<WUT>.
3. After an elapse of the warm-up time, the device restarts normal operation beginning with the instruction next to one that placed it in STOP mode. At this time, the prescaler and divider for the timing generator start from the zero-cleared state.

Table 2-2 Warm-up Time (Example:  $f_c = 20$  MHz)

WUT	Warm-up Time [ms]	
	When Returning to NORMAL Mode	
	DV1CK = 0	DV1CK = 1
00	9.831	19.662
01	3.277	6.554
10	0.819	1.638
11	Reserved	Reserved

Note: Because the warm-up time is obtained from the fundamental clock by dividing it, if the oscillation frequency fluctuates while exiting STOP mode, the warm-up time becomes to have some error. Therefore, the warm-up time must be handled as an approximate value.

The device can also be released from STOP mode by pulling the  $\overline{\text{RESET}}$  pin input low, in which case the device is immediately reset as is normally reset by  $\overline{\text{RESET}}$ . After reset, the device starts operating from NORMAL mode.

Note: When exiting STOP mode while the device is retained at low voltage, the following caution is required.

Before exiting STOP mode, the power supply voltage must be raised to the operating voltage. At this time, the  $\overline{\text{RESET}}$  pin level also is high and rises along with the power supply voltage. If the device has a time-constant circuit added external to the chip, the voltage on  $\overline{\text{RESET}}$  pin input does not rise as fast as the power supply voltage. Therefore, if the voltage level on  $\overline{\text{RESET}}$  pin input is below the  $\overline{\text{RESET}}$  pin's noninverted, high-level input voltage (hysteresis input), the device may be reset.

Not for New Design

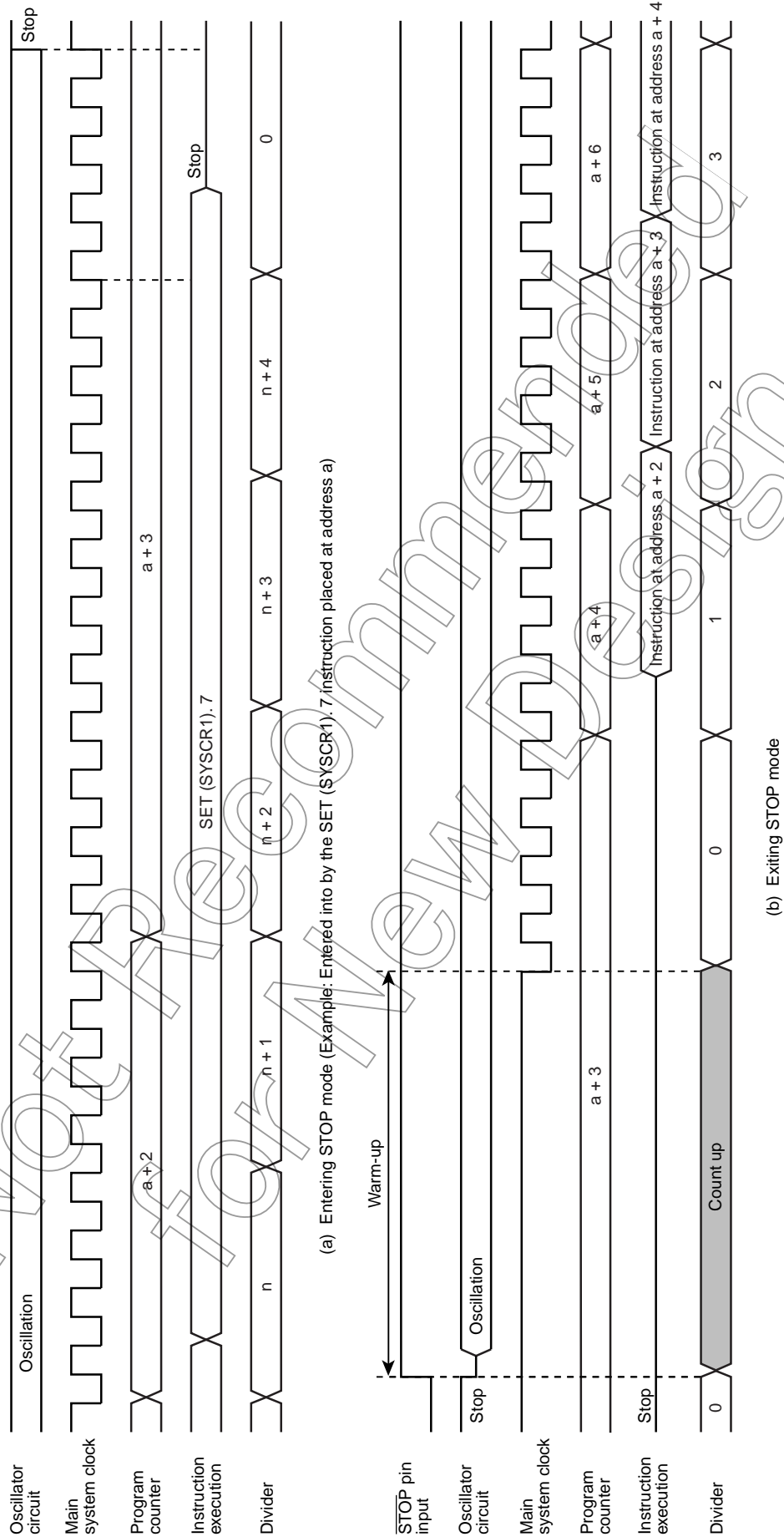

Figure 2-9 Entering and Exiting STOP Mode (when DV1CK = 0)

(2) IDLE mode

IDLE mode is controlled by System Control Register 2 (SYSCR2) and a maskable interrupt. During IDLE mode, the device retains the following state.

1. The CPU and watchdog timer stop operating.  
The peripheral hardware continues operating.
2. The data memory, register, program status word, and port output latch hold the state in which they were immediately before entering IDLE mode.
3. The program counter holds the instruction address two instructions ahead the one that placed the device in IDLE mode.

Example :Placing the device in IDLE mode

SET (SYSCR2) . 4

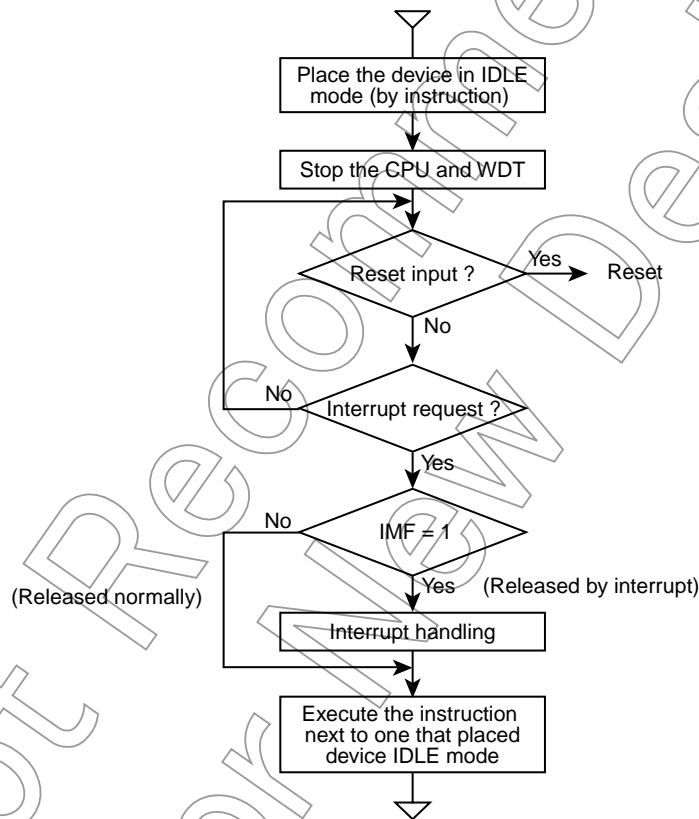

Figure 2-10 IDLE Mode

The device can be released from IDLE mode normally or by an interrupt as selected with the interrupt master enable flag (IMF).

a. Released normally (when IMF = 0)

The device can be released from IDLE mode by the interrupt source enabled by the interrupt individual enable flag (EF), and restarts execution beginning with the instruction next to one that placed it in IDLE mode. The interrupt latch (IL) for the interrupt source used to exit IDLE mode normally needs to be cleared to 0 using a load instruction.

b. Released by interrupt (when IMF = 1)

The device can be released from IDLE mode by the interrupt source enabled by the interrupt individual enable flag (EF), and enters interrupt handling. After interrupt handling, the device returns to the instruction next to one that placed it in IDLE mode.

The device can also be released from IDLE mode by pulling the  $\overline{\text{RESET}}$  pin input low, in which case the device is immediately reset as is normally reset by  $\overline{\text{RESET}}$ . After reset, the device starts operating from NORMAL mode.

Note: If a watchdog timer interrupt occurs immediately before entering IDLE mode, the device processes the watchdog timer interrupt without entering IDLE mode.

Not Recommended for New Design



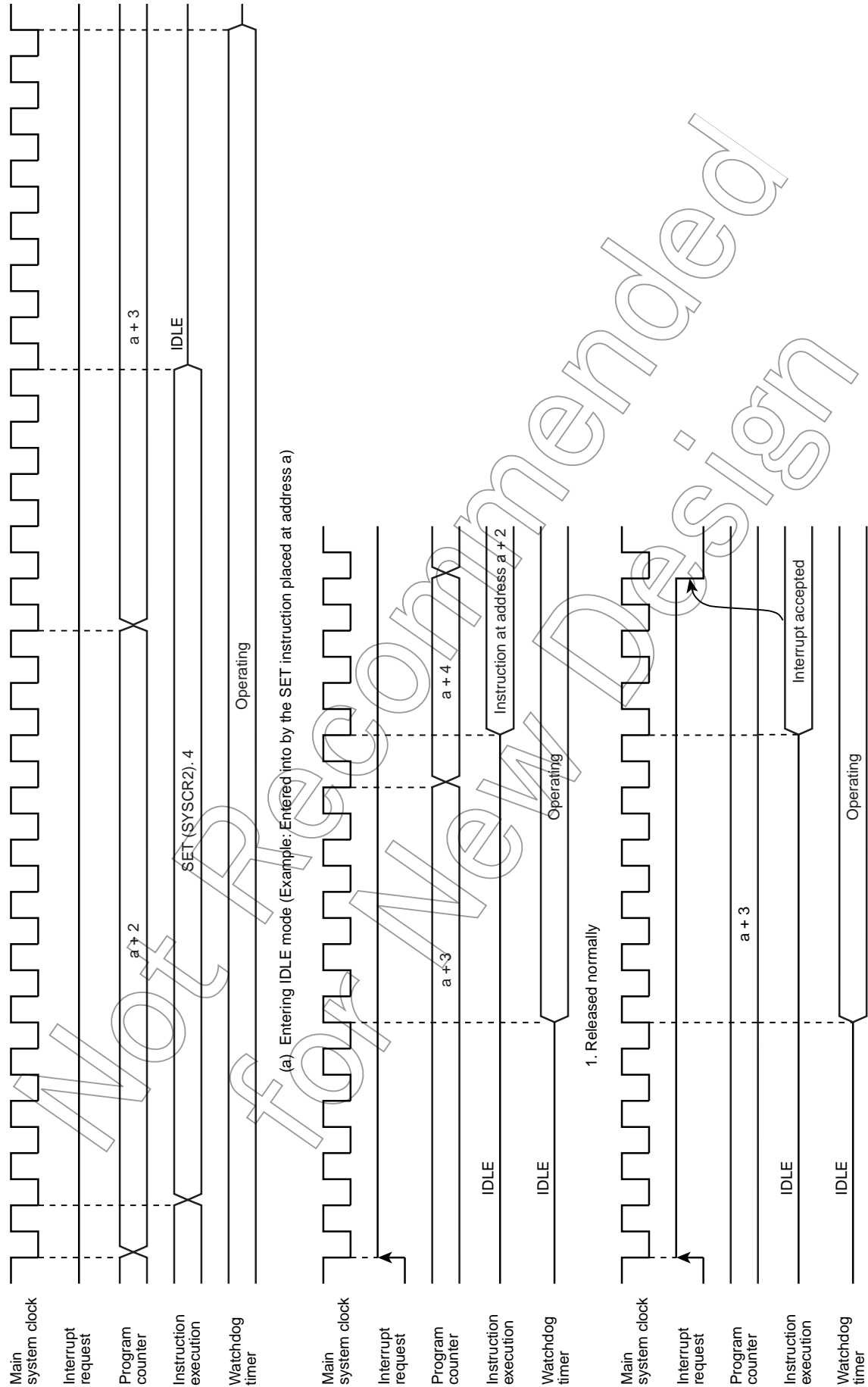

Figure 2-11 Entering and Exiting IDLE Mode

### 2.1.5 Reset Circuit

The TMP88CS42NG has four ways to generate a reset: external reset input, address trap reset, watchdog timer reset and system clock reset.

Table 2-3 shows how the internal hardware is initialized by reset operation.

At power-on time, the internal cause reset circuits (watchdog timer reset, address trap reset, and system clock reset) are not initialized.

Table 2-3 Internal Hardware Initialization by Reset Operation

Internal Hardware	Initial Value	Internal Hardware	Initial Value
Program Counter (PC)	(FFFFEH to FFFFCH)	Prescaler and divider for the timing generator	0
Stack Pointer (SP)	Not initialized		
General-purpose Registers (W, A, B, C, D, E, H, L)	Not initialized		
Register Bank Selector (RBS)	0	Watchdog timer	Enable
Jump Status Flag (JF)	1		
Zero Flag (ZF)	Not initialized	Output latch of input/output port	See description of each input/output port.
Carry Flag (CF)	Not initialized		
Half Carry Flag (HF)	Not initialized		
Sign Flag (SF)	Not initialized		
Overflow Flag (VF)	Not initialized		
Interrupt Master Enable Flag (IMF)	0		
Interrupt Individual Enable Flag (EF)	0	Control register	See description of each control register.
Interrupt Latch (IL)	0		
Interrupt Nesting Flag (INF)	0	RAM	Not initialized

#### 2.1.5.1 External Reset Input

The  $\overline{\text{RESET}}$  pin is a hysteresis input with a pull-up resistor included. By holding the  $\overline{\text{RESET}}$  pin low for at least three machine cycles ( $12/f_c$  [s]) or more while the power supply voltage is within the rated operating voltage range and the oscillator is oscillating stably, the device is reset and its internal state is initialized.

When the  $\overline{\text{RESET}}$  pin input is released back high, the device is freed from reset and starts executing the program beginning with the vector address stored at addresses FFFFCH to FFFFEH.

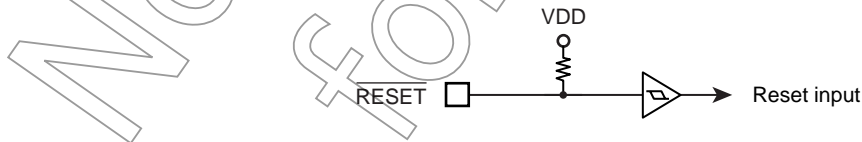

Figure 2-12 Reset Circuit

#### 2.1.5.2 Address Trap Reset

If the CPU should start looping for reasons of noise, etc. and attempts to fetch instructions from the internal RAM, SFR or DBR area, the device generates an internal reset.

The address trap permission/prohibition is set by the address trap reset control register (ATAS,ATKEY). The address trap is permitted initially and the internal reset is generated by fetching from internal RAM,SFR or DBR area. If the address trap is prohibited, instructions in the internal RAM area can be executed.

### Address Trap Control Register

ATAS (1F94H)	7	6	5	4	3	2	1	0	(initial value: **** **0)
	-	-	-	-	-	-	-	ATAS	

ATAS	Select the address trap permission / prohibition	0: Permit address trap 1: Prohibit address trap (It may be available after setting control code for ATKEY register)	Write only
------	--	---	------------

### Address Trap Control Code Register

ATKEY (1F95H)	7	6	5	4	3	2	1	0	(initial value: **** ***)

ATKEY	Write control code to prohibit address trap	D2H: Address trap prohibition code Others: Ineffective	Write only
-------	---	---	------------

Note: Read-modify-write instructions, such as a bit manipulation, cannot access ATAS or ATKEY register because these register are write only.

Note 1: In development tools, address trap cannot be prohibited in the internal RAM,SFR or DBR area with the address trap control registers. When using development tools, even if the address trap permission/prohibition setting is changed in the user's program, this change is ineffective. To execute instructions from the RAM area, development tools must be set accordingly.

Note 2: While the SWI instruction at an address immediately before the address trap area is executing, the program counter is incremented to point to the next address in the address trap area; an address trap is therefore taken immediately.

#### Development tool setting

- To prohibit the address trap:
  1. Modify the iram (mapping attribute) area to (00040H to 000BFH) in the memory map window.
  2. Set 000C0H to "address trap prohibition area" as a new eram (mapping attribute) area.
  3. Load the user program
  4. Execute the address trap prohibition code in the user's program

#### 2.1.5.3 Watchdog Timer Reset

Refer to the Section "Watchdog Timer."

#### 2.1.5.4 System Clock Reset

When SYSCR2<XEN> is cleared to 0 or when SYSCR2<XEN> is cleared to 0 while SYSCR2<SYSCK> = 0, the system clock is turned off, causing the CPU to become locked up. To prevent this problem, upon detecting SYSCR2<XEN> = 0, SYSCR2<XEN> = SYSCR2<SYSCK> = 0 or SYSCR2<SYSCK> = 1, the device automatically generates an internal reset signal to let the system clock continue oscillating.

### 3. Interrupt Control Circuit

The TMP88CS42NG has a total of 35 interrupt sources excluding reset. Interrupts can be nested with priorities. Two of the internal interrupt sources are pseudo nonmaskable while the rest are maskable.

Interrupt sources are provided with interrupt latches (IL), which hold interrupt requests, and independent vectors. The interrupt latch is set to “1” by the generation of its interrupt request which requests the CPU to accept its interrupts. Interrupts are enabled or disabled by software using the interrupt master enable flag (IMF) and interrupt enable flag (EF). If more than one interrupts are generated simultaneously, interrupts are accepted in order which is dominated by hardware. However, there are no prioritized interrupt factors among non-maskable interrupts.

Interrupt Factors		Enable Condition	Interrupt Latch	Vector Address	Priority
Internal/External	(Reset)	Nonmaskable	–	FFFFC	High 0
Internal	INTSWI (Software interrupt)	Pseudo nonmaskable	–	FFFF8	1
Internal	INTWDT (Watchdog timer interrupt)	Pseudo nonmaskable	IL2	FFFF4	2
External	INT0 (External interrupt 0)	IMF•EF3 = 1, INT0EN = 1	IL3	FFFF0	3
	Reserved	IMF•EF4 = 1	IL4	FFFE4	4
External	INT1 (External interrupt 1)	IMF•EF5 = 1	IL5	FFFE8	5
Internal	INTTBT (TBT interrupt)	IMF•EF6 = 1	IL6	FFFE4	6
	Reserved	IMF•EF7 = 1	IL7	FFFE0	7
Internal	INTEMG1 (ch1 Error detect interrupt)	IMF•EF8 = 1	IL8	FFFD4	8
Internal	INTEMG2 (ch2 Error detect interrupt)	IMF•EF9 = 1	IL9	FFFD8	9
Internal	INTCLM1 (ch1 Overload protection interrupt)	IMF•EF10 = 1	IL10	FFFD4	10
Internal	INTCLM2 (ch2 Overload protection interrupt)	IMF•EF11 = 1	IL11	FFFD0	11
Internal	INTTMR31 (ch1 Timer 3 interrupt)	IMF•EF12 = 1	IL12	FFFC4	12
Internal	INTTMR32 (ch2 Timer 3 interrupt)	IMF•EF13 = 1	IL13	FFFC8	13
	Reserved	IMF•EF14 = 1	IL14	FFFC4	14
External	INT5 (External interrupt 5)	IMF•EF15 = 1	IL15	FFFC0	15
Internal	INTPDC1 (ch1 Position detect interrupt)	IMF•EF16 = 1	IL16	FFFB4	16
Internal	INTPDC2 (ch2 Position detect interrupt)	IMF•EF17 = 1	IL17	FFFB8	17
Internal	INTPWM1 (ch1 Waveform generator interrupt)	IMF•EF18 = 1	IL18	FFFB4	18
Internal	INTPWM2 (ch2 Waveform generator interrupt)	IMF•EF19 = 1	IL19	FFFB0	19
Internal	INTEDT1 (ch1 Electric angle Timer interrupt)	IMF•EF20 = 1	IL20	FFFA4	20
Internal	INTEDT2 (ch2 Electric angle Timer interrupt)	IMF•EF21 = 1	IL21	FFFA8	21
Internal	INTTMR11 (ch1 Timer1 interrupt)	IMF•EF22 = 1	IL22	FFFA4	22
Internal	INTTMR12 (ch2 Timer1 interrupt)	IMF•EF23 = 1	IL23	FFFA0	23
Internal	INTTMR21 (ch1 Timer2 interrupt)	IMF•EF24 = 1	IL24	FFF94	24
Internal	INTTMR22 (ch2 Timer2 interrupt)	IMF•EF25 = 1	IL25	FFF98	25
Internal	INTTC1 (TC1 interrupt)	IMF•EF26 = 1	IL26	FFF94	26
Internal	INTCTC1 (CTC interrupt)	IMF•EF27 = 1	IL27	FFF90	27
Internal	INTTC6 (TC6 8bit/16bit interrupt)	IMF•EF28 = 1	IL28	FFF84	28
External	INT2 (External interrupt 2)	IMF•EF29 = 1	IL29	FFF88	29
External	INT3 (External interrupt 3)	IMF•EF30 = 1	IL30	FFF84	30
External	INT4 (External interrupt 4)	IMF•EF31 = 1	IL31	FFF80	31
Internal	INTRXD (UART receive interrupt)	IMF•EF32 = 1	IL32	FFF3C	32
Internal	INTTXD (UART transmit interrupt)	IMF•EF33 = 1	IL33	FFF38	33
Internal	INTSIO (SIO interrupt)	IMF•EF34 = 1	IL34	FFF34	34
Internal	INTTC3 (TC3 interrupt)	IMF•EF35 = 1	IL35	FFF30	35
Internal	INTTC4 (TC4 interrupt)	IMF•EF36 = 1	IL36	FFF24	36
Internal	INTTC5 (TC5 interrupt)	IMF•EF37 = 1	IL37	FFF28	37
Internal	INTADC (A/D converter interrupt)	IMF•EF38 = 1	IL38	FFF24	Low 38

Note 1: To use the watchdog timer interrupt (INTWDT), clear WDTTCR1<WDTOUT> to "0" (It is set for the "Reset request" after reset is released). It is described in the section "Watchdog Timer" for details.

### 3.1 Interrupt latches (IL38 to IL2)

An interrupt latch is provided for each interrupt source, except for a software interrupt and an executed the undefined instruction interrupt. When interrupt request is generated, the latch is set to "1", and the CPU is requested to accept the interrupt if its interrupt is enabled. The interrupt latch is cleared to "0" immediately after accepting interrupt. All interrupt latches are initialized to "0" during reset.

The interrupt latches are located on address 003CH, 003DH, 002EH, 002FH and 002BH in SFR area. Each latch can be cleared to "0" individually by instruction. However, IL2 and IL3 should not be cleared to "0" by software. For clearing the interrupt latch, load instruction should be used and then IL2 should be set to "1". If the read-modify-write instructions such as bit manipulation or operation instructions are used, interrupt request would be cleared inadequately if interrupt is requested while such instructions are executed.

Since interrupt latches can be read, the status for interrupt requests can be monitored by software. But interrupt latches are not set to "1" by an instruction.

Note: In main program, before manipulating the interrupt enable flag (EF) or the interrupt latch (IL), be sure to clear IMF to "0" (Disable interrupt by DI instruction). Then set IMF newly again as required after operating on the EF or IL (Enable interrupt by EI instruction)  
 In interrupt service routine, because the IMF becomes "0" automatically, clearing IMF need not execute normally on interrupt service routine. However, if using multiple interrupt on interrupt service routine, manipulating EF or IL should be executed before setting IMF="1".

Example 1 :Clears interrupt latches

```

DI                                ; IMF ← 0
LD    (ILL), 1110100000111111B    ; IL2 to IL7 ← 0
LD    (ILH), 1110100000111111B    ; IL8 to IL15 ← 0
LD    (ILE), 1110100000111111B    ; IL16 to IL23 ← 0
LD    (ILD), 1110100000111111B    ; IL24 to IL31 ← 0
LD    (ILC), 1110100000111111B    ; IL32 to IL38 ← 0
EI                                ; IMF ← 1
    
```

Example 2 :Reads interrupt latches

```

LD    WA, (ILL)                   ; W ← (ILH), A ← (ILL)
LD    BC, (ILE)                   ; B ← (ILD), C ← (ILE)
LD    D, (ILC)                    ; D ← (ILC)
    
```

Example 3 :Tests interrupt latches

```

TEST    (ILL), 7                  ; if IL7 = 1 then jump
JR      F, SSET
    
```

## 3.2 Interrupt enable register (EIR)

The interrupt enable register (EIR) enables and disables the acceptance of interrupts, except for the pseudo non-maskable interrupts (Software interrupt, undefined instruction interrupt, address trap interrupt and watchdog interrupt). Pseudo non-maskable interrupt is accepted regardless of the contents of the EIR.

The EIR consists of an interrupt master enable flag (IMF) and the individual interrupt enable flags (EF). These registers are located on address 003AH, 003BH, 002CH, 002DH and 002AH in SFR area, and they can be read and written by an instructions (Including read-modify-write instructions such as bit manipulation or operation instructions).

### 3.2.1 Interrupt master enable flag (IMF)

The interrupt enable register (IMF) enables and disables the acceptance of the whole maskable interrupt. While IMF = "0", all maskable interrupts are not accepted regardless of the status on each individual interrupt enable flag (EF). By setting IMF to "1", the interrupt becomes acceptable if the individuals are enabled.

When an interrupt is accepted, IMF is cleared to "0" after the latest status on IMF is stacked. Thus the maskable interrupts which follow are disabled temporarily. IMF flag is set to "1" by the maskable interrupt return instruction [RETI] after executing the interrupt service program routine, and MCU can accept the interrupt again. The latest interrupt request is generated already, it is available immediately after the [RETI] instruction is executed.

On the pseudo non-maskable interrupt, the non-maskable return instruction [RETN] is adopted. In this case, IMF flag is set to "1" only when it performs the pseudo non-maskable interrupt service routine on the interrupt acceptable status (IMF=1). However, IMF is set to "0" in the pseudo non-maskable interrupt service routine, it maintains its status (IMF="0").

The IMF is located on bit0 in EIRL (Address: 003AH in SFR), and can be read and written by an instruction. The IMF is normally set and cleared by [EI] and [DI] instruction respectively. During reset, the IMF is initialized to "0".

### 3.2.2 Individual interrupt enable flags (EF38 to EF3)

Each of these flags enables and disables the acceptance of its maskable interrupt. Setting the corresponding bit of an individual interrupt enable flag to "1" enables acceptance of its interrupt, and setting the bit to "0" disables acceptance. During reset, all the individual interrupt enable flags (EF38 to EF3) are initialized to "0" and all maskable interrupts are not accepted until they are set to "1".

Note: In main program, before manipulating the interrupt enable flag (EF) or the interrupt latch (IL), be sure to clear IMF to "0" (Disable interrupt by DI instruction). Then set IMF newly again as required after operating on the EF or IL (Enable interrupt by EI instruction)

In interrupt service routine, because the IMF becomes "0" automatically, clearing IMF need not execute normally on interrupt service routine. However, if using multiple interrupt on interrupt service routine, manipulating EF or IL should be executed before setting IMF="1".

Example 1: Enables interrupts individually and sets IMF

```

DI                                     ; IMF ← 0
SET      (EIRL), .5                    ; EF5 ← 1
CLR      (EIRL), .6                    ; EF6 ← 0
CLR      (EIRH), .4                    ; EF12 ← 0
CLR      (EIRD), .0                   ; EF24 ← 0
:
EI                                     ; IMF ← 1
    
```

Interrupt Latches

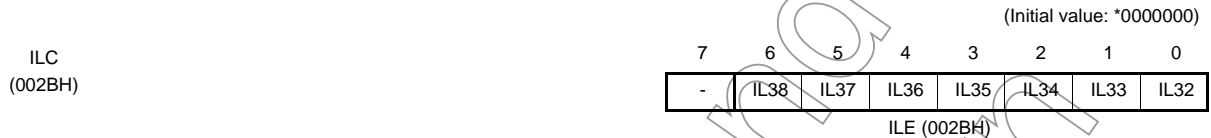
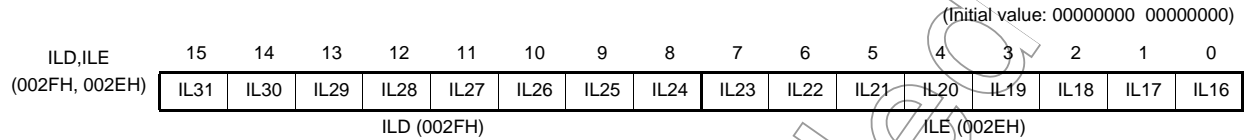
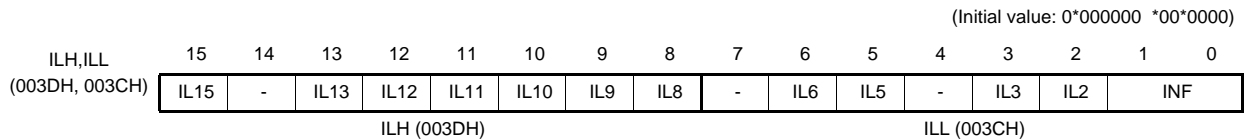

IL38 to IL2	Interrupt latches	Read	Write	R/W
		0: No interrupt request 1: Interrupt request	0: Clears the interrupt request (Note1) 1: (Unable to set interrupt latch)	
INF	Interrupt Nesting Flag	00: Out of interrupt service 01: On interrupt service of level 1 10: On interrupt service of more than level 2 11: On interrupt service of more than level 3	00: Reserved 01: Clear the nesting counter 10: Count-down 1 step for the nesting counter (Note2) 11: Reserved	

Note 1: IL2 cannot alone be cleared.

Note 2: Unable to detect the under-flow of counter.

Note 3: The nesting counter is set "0" initially, it performs count-up by the interrupt acceptance and count-down by executing the interrupt return instruction.

Note 4: In main program, before manipulating the interrupt enable flag (EF) or the interrupt latch (IL), be sure to clear IMF to "0" (Disable interrupt by DI instruction). Then set IMF newly again as required after operating on the EF or IL (Enable interrupt by EI instruction)

In interrupt service routine, because the IMF becomes "0" automatically, clearing IMF need not execute normally on interrupt service routine. However, if using multiple interrupt on interrupt service routine, manipulating EF or IL should be executed before setting IMF="1".

Note 5: Do not clear IL with read-modify-write instructions such as bit operations.

Interrupt Enable Registers

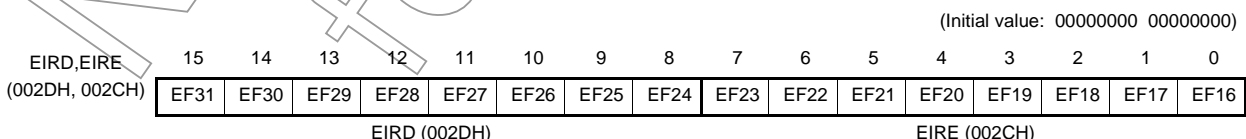
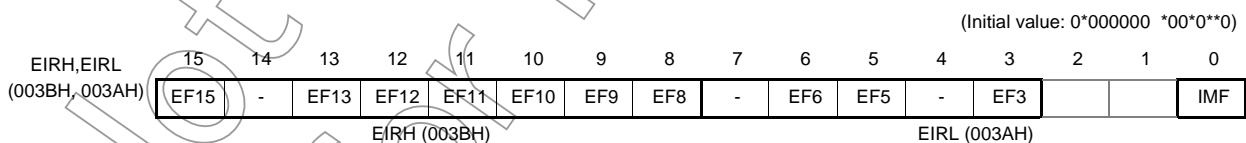

EF38 to EF3	Individual-interrupt enable flag (Specified for each bit)	0: Disables the acceptance of each maskable interrupt. 1: Enables the acceptance of each maskable interrupt.	R/W
IMF	Interrupt master enable flag	0: Disables the acceptance of all maskable interrupts 1: Enables the acceptance of all maskable interrupts	

Note 1: Do not set IMF and the interrupt enable flag (EF38 to EF3) to "1" at the same time.

Note 2: In main program, before manipulating the interrupt enable flag (EF) or the interrupt latch (IL), be sure to clear IMF to "0" (Disable interrupt by DI instruction). Then set IMF newly again as required after operating on the EF or IL (Enable interrupt by EI instruction)

In interrupt service routine, because the IMF becomes "0" automatically, clearing IMF need not execute normally on interrupt service routine. However, if using multiple interrupt on interrupt service routine, manipulating EF or IL should be executed before setting IMF="1".

Not Recommended  
for New Design



### 3.3 Interrupt Sequence

An interrupt request, which raised interrupt latch, is held, until interrupt is accepted or interrupt latch is cleared to “0” by resetting or an instruction. Interrupt acceptance sequence requires 12 machine cycles (2.4 μs @20 MHz) after the completion of the current instruction. The interrupt service task terminates upon execution of an interrupt return instruction [RETI] (for maskable interrupts) or [RETN] (for non-maskable interrupts). Figure 3-1 shows the timing chart of interrupt acceptance processing.

#### 3.3.1 Interrupt acceptance processing is packaged as follows.

- The interrupt master enable flag (IMF) is cleared to “0” in order to disable the acceptance of any following interrupt.
- The interrupt latch (IL) for the interrupt source accepted is cleared to “0”.
- The contents of the program counter (PC) and the program status word, including the interrupt master enable flag (IMF), are saved (Pushed) on the stack in sequence of PSWH, PSWL, PCE, PCH, PCL. Meanwhile, the stack pointer (SP) is decremented by 5.
- The entry address (Interrupt vector) of the corresponding interrupt service program, loaded on the vector table, is transferred to the program counter.
- Read the RBS control code from the vector table, add its MSB(4bit) to the register bank selector (RBS).
- Count up the interrupt nesting counter.
- The instruction stored at the entry address of the interrupt service program is executed.

Note: When the contents of PSW are saved on the stack, the contents of IMF are also saved.

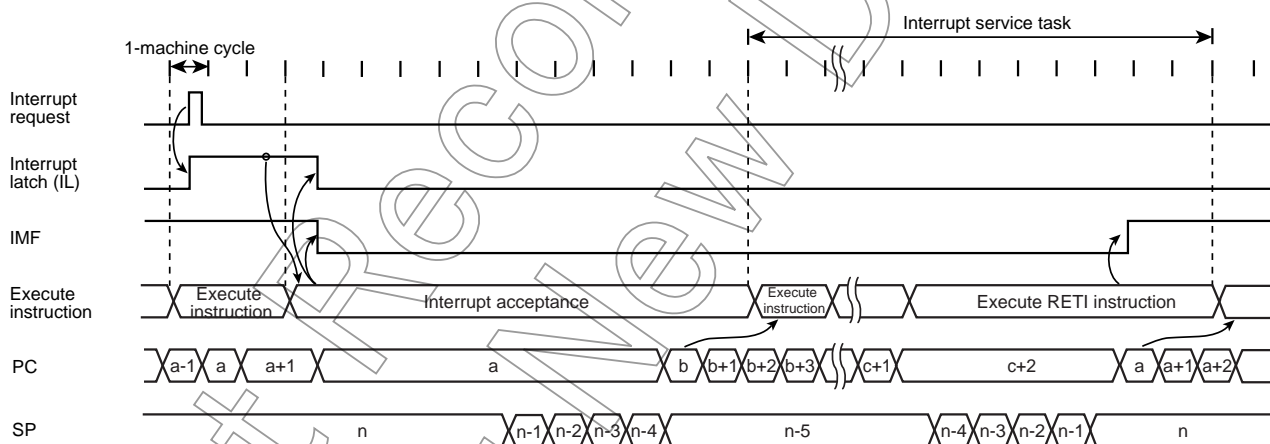

Note 1: a: Return address, b: Entry address, c: Address which RETI instruction is stored

Note 2: On condition that interrupt is enabled, it takes 62/fc [s] at maximum (If the interrupt latch is set at the first machine cycle on 15 cycle instruction) to start interrupt acceptance processing since its interrupt latch is set.

Figure 3-1 Timing Chart of Interrupt Acceptance/Return Interrupt Instruction

Example: Correspondence between vector table address for INTTBT and the entry address of the interrupt service program

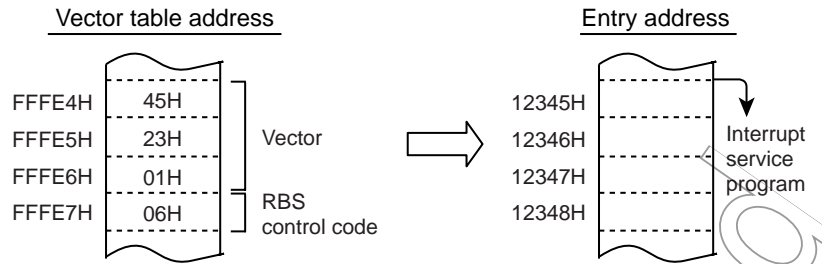

Figure 3-2 Vector table address,Entry address

A maskable interrupt is not accepted until the IMF is set to “1” even if the maskable interrupt higher than the level of current servicing interrupt is requested.

In order to utilize nested interrupt service, the IMF is set to “1” in the interrupt service program. In this case, acceptable interrupt sources are selectively enabled by the individual interrupt enable flags. But don’t use the read-modify-write instruction for EIRL(0003AH) on the pseudo non-maskable interrupt service task.

To avoid overloaded nesting, clear the individual interrupt enable flag whose interrupt is currently serviced, before setting IMF to “1”. As for non-maskable interrupt, keep interrupt service shorten compared with length between interrupt requests; otherwise the status cannot be recovered as non-maskable interrupt would simply nested.

### 3.3.2 Saving/restoring general-purpose registers

During interrupt acceptance processing, the program counter (PC) and the program status word (PSW, includes IMF) are automatically saved on the stack, but the accumulator and others are not. These registers are saved by software if necessary. When multiple interrupt services are nested, it is also necessary to avoid using the same data memory area for saving registers. The following four methods are used to save/restore the general-purpose registers.

#### 3.3.2.1 Using Automatic register bank switching

By switching to non-use register bank, it can restore the general-purpose register at hige speed.

Usually the bank register "0" is assigned for main task and the bank register "1 to 15" are for the each interrupt service task. To make up its data memory efficiency, the common bank is assigned for non-multiple intrrupt factor.

It can return back to main-flow by executing the interrupt return instructions ([RETI]/[RETN]) from the current interrupt register bank automatically. Thus, no need to restore the RBS by a program.

Example :Register bank switching

```

PINTxx:      (interrupt processing)          ; Begin of interrupt routine
             RETI                          ; End of interrupt
             :
VINTxx:      DP          PINTxx             ; PINTxx vector address setting
             DB          1                  ; RBS <- RBS + 1      RBS setting on PINTxx
    
```

#### 3.3.2.2 Using register bank switching

By switching to non-use register bank, it can restore the general-purpose register at hige speed. Usually the bank register "0" is assigned for main task and the bank register "1 to 15" are for the each interrupt service task.

Example :Register bank switching

```

PINTxx:    LD      RBS, n          ; RBS <- n      Begin of interrupt routine
           (interrupt processing)
           RETI                    ; End of interrupt , restore RBS and interrupt return
           :
VINTxx:    DP      PINTxx         ; PINTxx vector address setting
           DB      0              ; RBS <- RBS + 0   RBS setting on PINTxx
    
```

### 3.3.2.3 Using PUSH and POP instructions

If only a specific register is saved or interrupts of the same source are nested, general-purpose registers can be saved/restored using the PUSH/POP instructions.

Example :Save/store register using PUSH and POP instructions

```

PINTxx:    PUSH    WA              ; Save WA register
           (interrupt processing)
           POP     WA              ; Restore WA register
           RETI                    ; RETURN
    
```

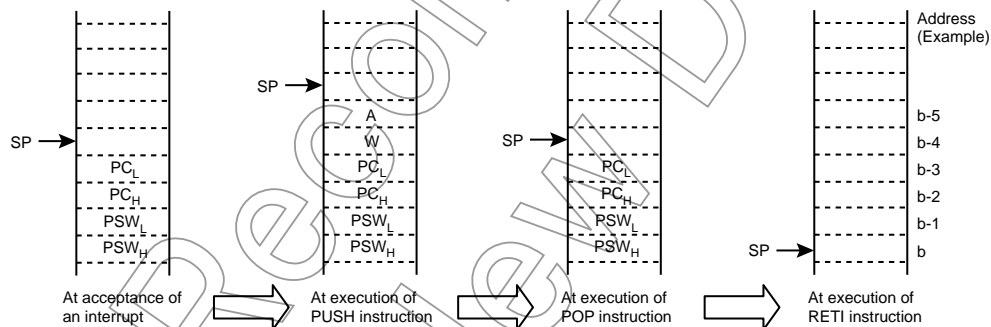

Figure 3-3 Save/store register using PUSH and POP instructions

### 3.3.2.4 Using data transfer instructions

To save only a specific register without nested interrupts, data transfer instructions are available.

Example :Save/store register using data transfer instructions

```

PINTxx:    LD      (GSAVA), A      ; Save A register
           (interrupt processing)
           LD      A, (GSAVA)     ; Restore A register
           RETI                    ; Return
    
```

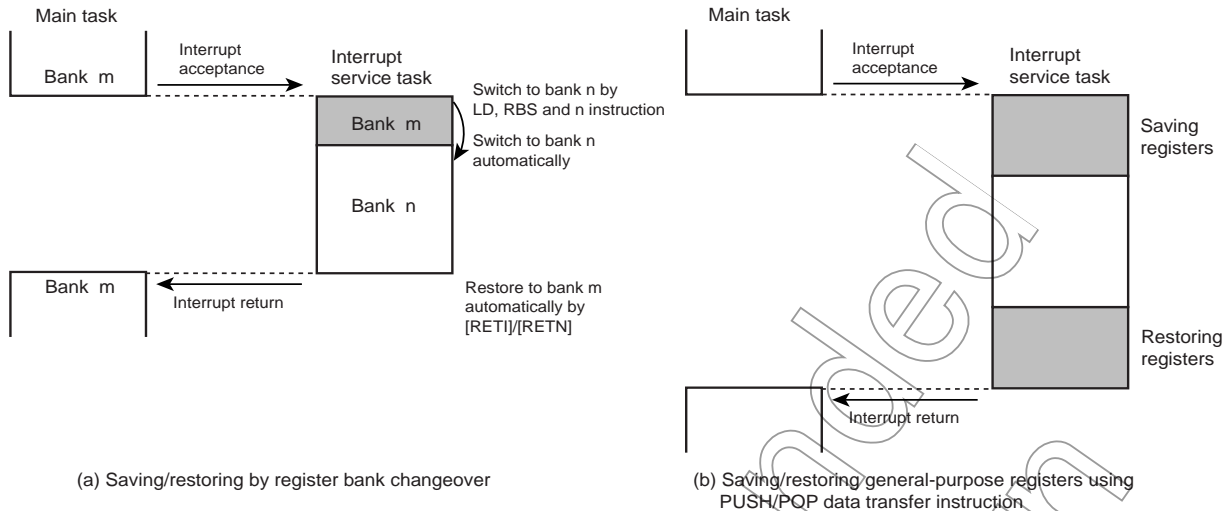

Figure 3-4 Saving/Restoring General-purpose Registers under Interrupt Processing

### 3.3.3 Interrupt return

Interrupt return instructions [RETI]/[RETN] perform as follows.

[RETI] Maskable Interrupt Return	[RETN] Non-maskable Interrupt Return
<ol style="list-style-type: none"> <li>1. The contents of the program counter and the program status word are restored from the stack.</li> <li>2. The stack pointer is incremented 5 times.</li> <li>3. The interrupt master enable flag is set to "1".</li> <li>4. The interrupt nesting counter is decremented, and the interrupt nesting flag is changed.</li> </ol>	<ol style="list-style-type: none"> <li>1. The contents of the program counter and the program status word are restored from the stack.</li> <li>2. The stack pointer is incremented 5 times.</li> <li>3. The interrupt master enable flag is set to "1" only when a non-maskable interrupt is accepted in interrupt enable status. However, the interrupt master enable flag remains at "0" when so clear by an interrupt service program.</li> <li>4. The interrupt nesting counter is decremented, and the interrupt nesting flag is changed.</li> </ol>

Interrupt requests are sampled during the final cycle of the instruction being executed. Thus, the next interrupt can be accepted immediately after the interrupt return instruction is executed.

Note: When the interrupt processing time is longer than the interrupt request generation time, the interrupt service task is performed but not the main task.

## 3.4 Software Interrupt (INTSW)

Executing the SWI instruction generates a software interrupt and immediately starts interrupt processing (INTSW is highest prioritized interrupt). However, if processing of a non-maskable interrupt is already underway, executing the SWI instruction will not generate a software interrupt but will result in the same operation as the NOP instruction.

Use the SWI instruction only for detection of the address error or for debugging.

### 3.4.1 Address error detection

FFH is read if for some cause such as noise the CPU attempts to fetch an instruction from a non-existent memory address during single chip mode. Code FFH is the SWI instruction, so a software interrupt is generated and an address error is detected. The address error detection range can be further expanded by writing FFH to unused areas of the program memory. Address trap reset is generated in case that an instruction is fetched from RAM, DBR or SFR areas.

### 3.4.2 Debugging

Debugging efficiency can be increased by placing the SWI instruction at the software break point setting address.

Not Recommended  
for New Design

### 3.5 External Interrupts

The TMP88CS42NG has 6 external interrupt inputs. These inputs are equipped with digital noise reject circuits (Pulse inputs of less than a certain time are eliminated as noise).

Edge selection is also possible with INT1 to INT4. The  $\overline{\text{INT0}}$ /P10 pin can be configured as either an external interrupt input pin or an input/output port, and is configured as an input port during reset.

Edge selection, and noise reject control and  $\overline{\text{INT0}}$ /P10 pin function selection are performed by the external interrupt control register (EINTCR).

Source	Pin	Sub-Pin	Enable Conditions	Release Edge (level)	Digital Noise Reject
INT0	$\overline{\text{INT0}}$	P10	IMF + EF3 + INT0EN=1	Falling edge	Pulses of less than 2/fc [s] are eliminated as noise. Pulses of 6/fc [s] or more are considered to be signals. (at CGCR<DV1CK>=0).
INT1	INT1	P11	IMF + EF5 = 1	Falling edge or Rising edge	Pulses of less than 15/fc or 63/fc [s] are eliminated as noise. Pulses of 48/fc or 192/fc [s] or more are considered to be signals. (at CGCR<DV1CK>=0).
INT2	INT2	P12/TC1	IMF + EF29 = 1		Pulses of less than 7/fc [s] are eliminated as noise. Pulses of 24/fc [s] or more are considered to be signals. (at CGCR<DV1CK>=0).
INT3	INT3	P21/TC3	IMF + EF30 = 1		
INT4	INT4	P22/TC4	IMF + EF31 = 1		
INT5	$\overline{\text{INT5}}$	P20/ $\overline{\text{STOP}}$	IMF + EF15 = 1	Falling edge	Pulses of less than 2/fc [s] are eliminated as noise. Pulses of 6/fc [s] or more are considered to be signals.

Note 1: In NORMAL or IDLE mode, if a signal with no noise is input on an external interrupt pin, it takes a maximum of "signal establishment time" from the input signal's edge to set the interrupt latch.

- (1) INT1 pin 49/fc [s] ( at EINTCR<INT1NC> = "1" ) , 193/fc [s] ( at EINTCR<INT1NC> = "0" )
- (2) INT2 to INT4 pins 25/fc [s]

Note 2: When EINTCR<INT0EN> = "0", IL3 is not set even if a falling edge is detected on the  $\overline{\text{INT0}}$  pin input.

Note 3: When a pin with more than one function is used as an output and a change occurs in data or input/output status, an interrupt request signal is generated in a pseudo manner. In this case, it is necessary to perform appropriate processing such as disabling the interrupt enable flag.

Not for New

External Interrupt Control Register

EINTCR      7            6            5            4            3            2            1            0  
(0037H)    INT1NC    INT0EN    INT4ES    INT3ES    INT2ES    INT1ES    (Initial value: 0000 000\*)

INT1NC	Noise reject time select	0: Pulses of less than $63/f_c$ [s] are eliminated as noise 1: Pulses of less than $15/f_c$ [s] are eliminated as noise	R/W
INT0EN	P10/ $\overline{\text{INT0}}$ pin configuration	0: P10 input/output port 1: $\overline{\text{INT0}}$ pin (Port P10 should be set to an input mode)	R/W
INT4 ES	INT4 edge select	00: Rising edge 01: Falling edge 10: Rising edge and Falling edge 11: H level	R/W
INT3 ES	INT3 edge select	0: Rising edge 1: Falling edge	R/W
INT2 ES	INT2 edge select		
INT1 ES	INT1 edge select		

Note 1:  $f_c$ : High-frequency clock [Hz], \*: Don't care

Note 2: When the external interrupt control register (EINTCR) is overwritten, the noise canceller may not operate normally. It is recommended that external interrupts are disabled using the interrupt enable register (EIR).

Note 3: The maximum time from modifying EINTCR<INT1NC> until a noise reject time is changed is  $2^6/f_c$ .

Note 4: In case  $\overline{\text{RESET}}$  pin is released while the state of INT4 pin keeps "H" level, the external interrupt 4 request is not generated even if the INT4 edge select(EINTCR<INT4ES>) is specified as "H" level. The rising edge is needed after  $\overline{\text{RESET}}$  pin is released.

Not Recommended for New Design

## 4. Special Function Register

The TMP88CS42NG adopts the memory mapped I/O system, and all peripheral control and transfers are performed through the special function register (SFR) or the data buffer register (DBR). The SFR is mapped on address 0000H to 003FH, DBR is mapped on address 01F80H to 01FFFH.

This chapter shows the arrangement of the special function register (SFR) and data buffer register (DBR) for TMP88CS42NG.

### 4.1 SFR

Address	Read	Write
0000H		P0DR
0001H		P1DR
0002H		P2DR
0003H		P3DR
0004H		P4DR
0005H		P5DR
0006H		P6DR
0007H		P7DR
0008H		Reserved
0009H		Reserved
000AH		P0CR
000BH		P1CR
000CH		HPWMCR
000DH		HPWMDR0
000EH		HPWMDR1
000FH		TC1CR
0010H		TC1DRAL
0011H		TC1DRAH
0012H		TC1DRBL
0013H		TC1DRBH
0014H		CTC1CR1
0015H		CTC1CR2
0016H	-	CTC1DRL
0017H	-	CTC1DRH
0018H		Reserved
0019H		Reserved
001AH		TC4CR
001BH		TC4DR
001CH		TC3DRA
001DH	TC3DRB	-
001EH		TC3CR
001FH		Reserved
0020H		TC5CR
0021H		TC6CR
0022H		TTREG5
0023H		TTREG6
0024H		PWREG5
0025H		PWREG6



Address	Read	Write
0026H		ADCCRA
0027H		ADCCRB
0028H	ADCRL	-
0029H	ADCRH	-
002AH		EIRC
002BH		ILC
002CH		EIRE
002DH		EIRD
002EH		ILE
002FH		ILD
0030H		CGCR
0031H		Reserved
0032H		Reserved
0033H		Reserved
0034H	-	WDTCR1
0035H	-	WDTCR2
0036H		TBTCR
0037H		EINTCR
0038H		SYSCR1
0039H		SYSCR2
003AH		EIRL
003BH		EIRH
003CH		ILL
003DH		ILH
003EH		PSWL
003FH		PSWH

Note 1: Do not access reserved areas by the program.

Note 2: - ; Cannot be accessed.

Note 3: Write-only registers and interrupt latches cannot use the read-modify-write instructions (Bit manipulation instructions such as SET, CLR, etc. and logical-operation instructions such as AND, OR, etc.).

Not For New Design

4.2 DBR

Address	PMD ch	Read	Write
1F80H			P0ODE
1F81H			-
1F82H			-
1F83H			P3ODE
1F84H			P4ODE
1F85H			P5ODE
1F86H			-
1F87H			-
1F88H			-
1F89H			P3CR
1F8AH			P4CR
1F8BH			P5CR
1F8CH			P6CR
1F8DH			P7CR
1F8EH			-
1F8FH			-
1F90H			UARTSEL
1F91H		UARTSR	UARTCRA
1F92H		-	UARTCRB
1F93H		RDBUF	TDBUF
1F94H		-	ATAS
1F95H		-	ATKEY
1F96H		-	SIOCR1
1F97H		SIOSR	SIOCR2
1F98H			SIOBR0
1F99H			SIOBR1
1F9AH			SIOBR2
1F9BH			SIOBR3
1F9CH			SIOBR4
1F9DH			SIOBR5
1F9EH			SIOBR6
1F9FH			SIOBR7
1FA0H	for PMD ch.1		PDCRA
1FA1H	for PMD ch.1		PDCRB
1FA2H	for PMD ch.1	PDCRC	-
1FA3H	for PMD ch.1		SDREG
1FA4H	for PMD ch.1		MTCRA
1FA5H	for PMD ch.1		MTCRB
1FA6H	for PMD ch.1	MCAPL	-
1FA7H	for PMD ch.1	MCAPH	-
1FA8H	for PMD ch.1		CMP1L
1FA9H	for PMD ch.1		CMP1H
1FAAH	for PMD ch.1		CMP2L
1FABH	for PMD ch.1		CMP2H
1FACH	for PMD ch.1		CMP3L
1FADH	for PMD ch.1		CMP3H
1FAEH	for PMD ch.1		MDCRA
1FAFH	for PMD ch.1		MDCRB

Address	PMD ch	Read	Write
1FB0H	for PMD ch.1		EMGCRA
1FB1H	for PMD ch.1		EMGCRB
1FB2H	for PMD ch.1		MDOUTL
1FB3H	for PMD ch.1		MDOUTH
1FB4H	for PMD ch.1	MDCNTL	-
1FB5H	for PMD ch.1	MDCNTH	-
1FB6H	for PMD ch.1		MDPRDL
1FB7H	for PMD ch.1		MDPRDH
1FB8H	for PMD ch.1		CMPUL
1FB9H	for PMD ch.1		CMPUH
1FBAH	for PMD ch.1		CMPVL
1FBBH	for PMD ch.1		CMPVH
1FBCH	for PMD ch.1		CMPWL
1FBDH	for PMD ch.1		CMPWH
1FBEH	for PMD ch.1		DTR
1FBFH	for PMD ch.1	-	EMGREL
1FC0H	for PMD ch.1		EDCRA
1FC1H	for PMD ch.1		EDCRB
1FC2H	for PMD ch.1		EDSETL
1FC3H	for PMD ch.1		EDSETH
1FC4H	for PMD ch.1		ELDEGL
1FC5H	for PMD ch.1		ELDEGH
1FC6H	for PMD ch.1		AMPL
1FC7H	for PMD ch.1		AMPH
1FC8H	for PMD ch.1	EDCAPL	-
1FC9H	for PMD ch.1	EDCAPH	-
1FCAH	for PMD ch.1	-	WFMDR
1FCBH			-
1FCCH			Reserved
1FCDH			Reserved
1FCEH			Reserved
1FCFH			Reserved
1FD0H	for PMD ch.2		PDCRA
1FD1H	for PMD ch.2		PDCRB
1FD2H	for PMD ch.2	PDCRC	-
1FD3H	for PMD ch.2		SDREG
1FD4H	for PMD ch.2		MTCRA
1FD5H	for PMD ch.2		MTCRB
1FD6H	for PMD ch.2	MCAPL	-
1FD7H	for PMD ch.2	MCAPH	-
1FD8H	for PMD ch.2		CMP1L
1FD9H	for PMD ch.2		CMP1H
1FDAH	for PMD ch.2		CMP2L
1FDBH	for PMD ch.2		CMP2H
1FDCH	for PMD ch.2		CMP3L
1FDDH	for PMD ch.2		CMP3H
1FDEH	for PMD ch.2		MDCRA
1FDFH	for PMD ch.2		MDCRB
1FE0H	for PMD ch.2		EMGCRA
1FE1H	for PMD ch.2		EMGCRB
1FE2H	for PMD ch.2		MDOUTL

Address	PMD ch	Read	Write
1FE3H	for PMD ch.2	MDOUTH	
1FE4H	for PMD ch.2	MDCNTL	-
1FE5H	for PMD ch.2	MDCNTH	-
1FE6H	for PMD ch.2	MDPRDL	
1FE7H	for PMD ch.2	MDPRDH	
1FE8H	for PMD ch.2	CMPUL	
1FE9H	for PMD ch.2	CMPUH	
1FEAH	for PMD ch.2	CMPVL	
1FEBH	for PMD ch.2	CMPVH	
1FECH	for PMD ch.2	CMPWL	
1FEDH	for PMD ch.2	CMPVH	
1FEEH	for PMD ch.2	DTR	
1FEFH	for PMD ch.2	-	EMGREL
1FF0H	for PMD ch.2	EDCRA	
1FF1H	for PMD ch.2	EDCRB	
1FF2H	for PMD ch.2	EDSETL	
1FF3H	for PMD ch.2	EDSETH	
1FF4H	for PMD ch.2	ELDEGL	
1FF5H	for PMD ch.2	ELDEGH	
1FF6H	for PMD ch.2	AMPL	
1FF7H	for PMD ch.2	AMPH	
1FF8H	for PMD ch.2	EDCAPL	-
1FF9H	for PMD ch.2	EDCAPH	-
1FFAH	for PMD ch.2	-	WFMDR
1FFBH			
1FFCH			Reserved
1FFDH			Reserved
1FFEH			Reserved
1FFFH			Reserved

Note 1: Do not access reserved areas by the program.

Note 2: - ; Cannot be accessed.

Note 3: Write-only registers and interrupt latches cannot use the read-modify-write instructions (Bit manipulation instructions such as SET, CLR, etc. and logical operation instructions such as AND, OR, etc.).

Not for New Design

Not Recommended  
for New Design

## 5. Input/Output Ports

The TMP88CS42NG contains 8 input/output ports comprised of 55 pins.

	Primary Function	Secondary Functions
Port P0	4-bit I/O port	Timer/counter input, serial interface input/output, and high-speed PWM output
Port P1	8-bit I/O port	External interrupt input, timer/counter input/output, divider output, and motor control circuit input
Port P2	3-bit I/O port	External interrupt input, timer/counter input/output, and STOP mode release signal input
Port P3	8-bit I/O port	Motor control input/output
Port P4	8-bit I/O port	Timer/counter output, serial interface input/output, motor control circuit input
Port P5	8-bit I/O port	Motor control circuit input/output
Port P6	8-bit I/O port	Analog input and motor control circuit output
Port P7	8-bit I/O port	Analog input and motor control circuit output

All output ports contain a latch, and the output data therefore are retained by the latch. But none of the input ports have a latch, so it is desirable that the input data be retained externally until it is read out, or read several times before being processed. Figure 5-1 shows input/output timing.

The timing at which external data is read in from input/output ports is S1 state in the read cycle of instruction execution. Because this timing cannot be recognized from the outside, transient input data such as chattering needs to be dealt with in a program. The timing at which data is forwarded to input/output ports is S2 state in the write cycle of instruction execution.

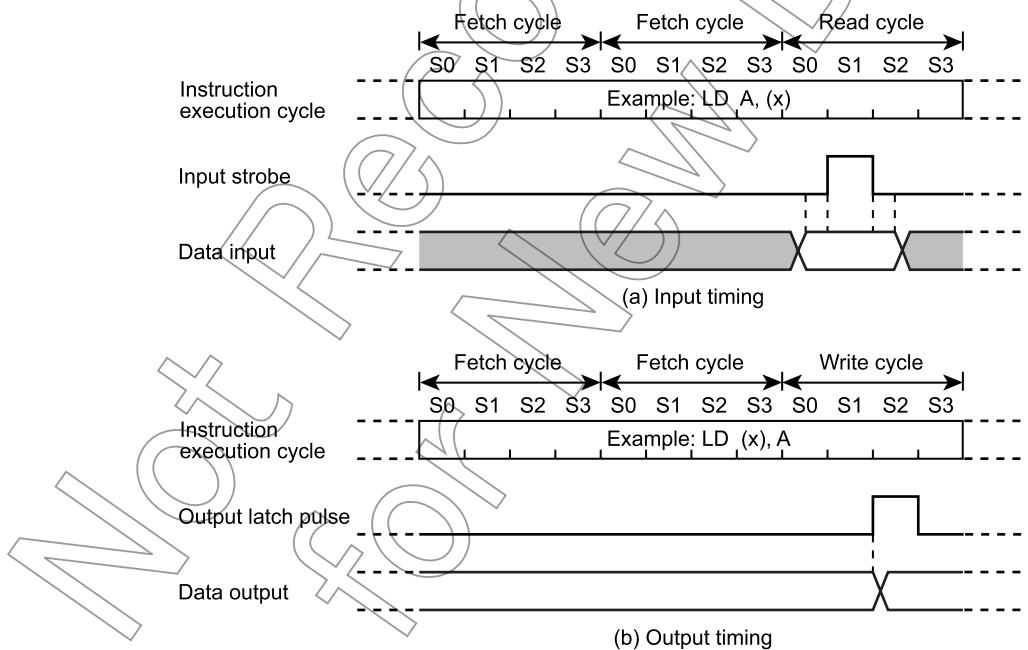

Note: The read/write cycle positions vary depending on instructions.

Figure 5-1 Example of Input/Output Timing

When an operation is performed for read from any input/output port except programmable input/output ports, whether the input value of the pin or the content of the output latch is read depends on the instruction executed, as shown below.

1. Instructions which read the content of the output latch

- XCH r, (src)
- SET/CLR/CPL (src).b
- SET/CLR/CPL (pp).g
- LD (src).b, CF
- LD (pp).b, CF
- XCH CF, (src). b
- ADD/ADDC/SUB/SUBB/AND/OR/XOR (src), n
- ADD/ADDC/SUB/SUBB/AND/OR/XOR (src), (HL) instructions, the (src) side thereof
- MXOR (src), m

2. Instructions which read the input value of the pin

Any instructions other than those listed above and ADD/ADDC/SUB/SUBB/AND/OR/XOR (src),(HL) instructions, the (HL) side thereof

Not Recommended  
for New Design

### 5.1 Port P0 (P03 to P00)

Port P0 is a 4-bit input/output port shared with serial interface input/output. This port is switched between input and output modes using the P0 port input/output control register (P0CR). When reset, the P0CR register is initialized to 0, with the P0 port set for input mode. Also, the output latch (P0DR) is initialized to 0 when reset.

The P0 port contains bitwise programmable open-drain control. The P0 port open-drain control register (P0ODE) is used to select open-drain or tri-state mode for the port. When reset, the P0ODE register is initialized to 0, with tri-state mode selected for the port.

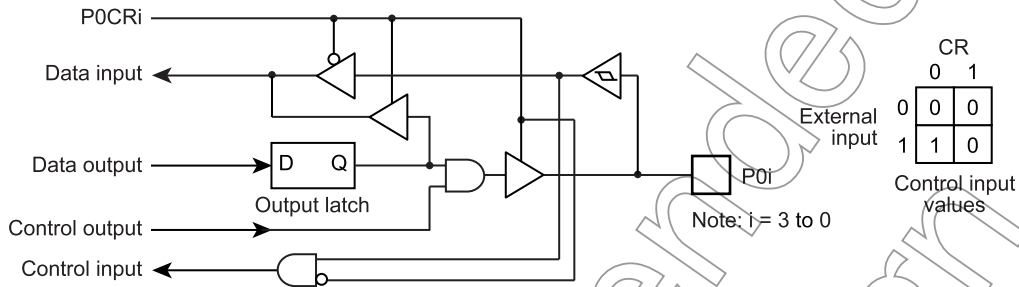

Figure 5-2 Port P0

#### P0 Port Input/Output Registers

	7	6	5	4	3	2	1	0	
P0DR (00000H)					P03 HPWM1	P02 HPWM0	P01 TC6O TXD2	P00 TC6I RXD2	Read/Write (Initial value: **** 0000) TC6O: PDO6, PWM6, PPG6
P0CR (0000AH)									(Initial value: **** 0000)

P0CR	P0 port input/output control (Specify bitwise)	0: Input mode 1: Output mode	R/W
------	--	---------------------------------	-----

	7	6	5	4	3	2	1	0	
P0ODE (01F80H)									(Initial value: **** 0000)

P0ODE	P0 port open-drain control (Specify bitwise)	0: Tri-state 1: Open drain	R/W
-------	--	-------------------------------	-----

Note 1: Even when open-drain mode is selected, the protective diode remains connected. Therefore, do not apply voltages exceeding  $V_{DD}$ .

Note 2: Read-Modify-Write (RMW) operation executes at open-drain mode is selected, read out the output latch states. When any other instruction is executed, external pin states is read out.

Note 3: \*: Don't care



## 5.2 Port P1 (P17 to P10)

Port P1 is an 8-bit input/output port shared with external interrupt input, timer/counter input/output, and divider output. This port is switched between input and output modes using the P1 port input/output control register (P1CR). When reset, the P1CR register is initialized to 0, with the P1 port set for input mode. Also, the output latch (P1DR) is initialized to 0 when reset.

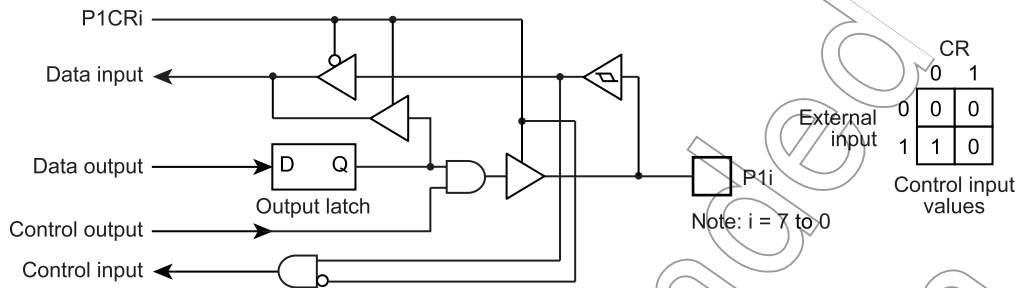

Figure 5-3 Port P1

### P1 Port Input/Output Registers

	7	6	5	4	3	2	1	0	
P1DR (00001H)	P17 PDW2	P16 PDV2	P15 PDU2	P14 PPG1 TC5O	P13 DVO TC5I	P12 INT2 TC1	P11 INT1	P10 INT0	Read/Write (Initial value: 0000 0000) TC5O: PDO5, PWM5

	7	6	5	4	3	2	1	0	
P1CR (0000BH)									(Initial value: 0000 0000)

P1CR	P1 port input/output control (Specify bitwise)	0: Input mode 1: Output mode	R/W
------	---	---------------------------------	-----

### 5.3 Port P2 (P22 to P20)

Port P2 is a 3-bit input/output port shared with external interrupt input and STOP mode release signal. When using this port as these functional pins or an input port, set the output latch to 1. When reset, the output latch is initialized to 1.

We recommend using the P20 pin as external interrupt input, STOP mode release signal input, or input port. When using this port as an output port, note that the interrupt latch is set by a falling edge of output pulse. And note that outputs on this port during STOP mode go to a high-impedance state even if SYSCR1<OUTEN> is set "1", because P20 port is also used as STOP port.

When a read instruction is executed on P2 port, indeterminate values are read in from bits 7 to 3.

When any read-modify-write instruction is executed on P2 port, the content of the output latch is read out. When any other instruction is executed, the external pin state is read out.

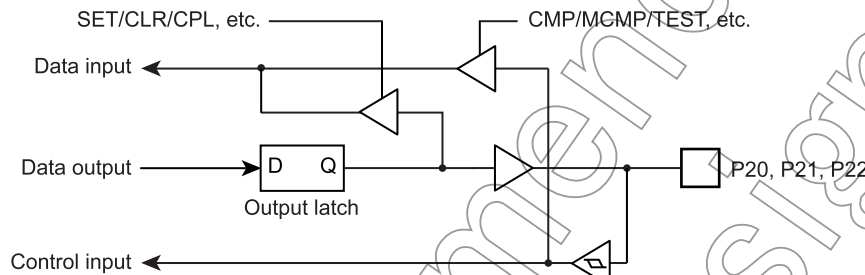

Figure 5-4 Port P2

#### P2 Port Input/Output Registers

	7	6	5	4	3	2	1	0	
P2DR (00002H)						P22 TC4 INT4 PWM4 PBO4	P21 TC3 INT3	P20 INT5 STOP	Read/Write (Initial value: **** *111)

Note 1: When a read instruction is executed on P2 port, indeterminate values are read in from bits 7 to 3.

Note 2: Port P20 is used as STOP pin. Therefore, when stop mode is started, SYSCR1<OUTEN> does not affect to P20, and P20 becomes High-Z mode.

Note 3: \*: Don't care

### 5.4 Port P3 (P37 to P30)

Port P3 is an 8-bit input/output port. This port is switched between input and output modes using the P3 port Input/output control register (P3CR). When reset, the P3CR register is initialized to 0, with the P3 port set for input mode. Also, the output latch (P3DR) is initialized to 0 when reset.

The P3 port contains bitwise programmable open-drain control. The P3 port open-drain control register (P3ODE) is used to select open-drain or tri-state mode for the port. When reset, the P3ODE register is initialized to 0, with tri-state mode selected for the port.

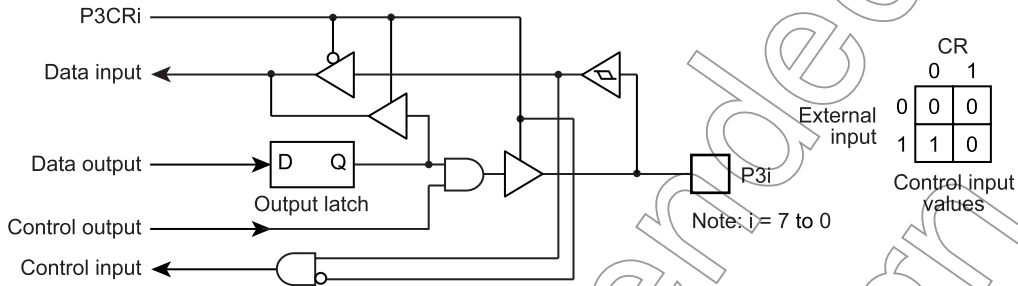

Figure 5-5 Port P3

#### P3 Port Input/Output Registers

P3DR (00003H)	7	6	5	4	3	2	1	0	Read/Write (Initial value: 0000 0000)
	P37 CL1	P36 EMG1	P35 U1	P34 V1	P33 W1	P32 X1	P31 Y1	P30 Z1	
P3CR (01F89H)	7	6	5	4	3	2	1	0	(Initial value: 0000 0000)
P3CR	P3 port input/output control (Specify bitwise)						0: Input mode 1: Output mode		R/W
P3ODE (01F83H)	7	6	5	4	3	2	1	0	(Initial value: 0000 0000)
P3ODE	P3 port open-drain control (Specify bitwise)						0: Tri-state 1: Open drain		R/W

Note 1: Even when open-drain mode is selected, the protective diode remains connected. Therefore, do not apply voltages exceeding  $V_{DD}$ .

Note 2: Read-modify-write (RMW) operation executes at open-drain mode is selected, read out the output latch states. When any other instruction is executed, external pin states is read out.

Note 3: For PMD circuit output, set the P3DR output latch to 1.

Note 4: When using P3 port as an input/output port, disable the EMG1 circuit.

### 5.5 Port P4 (P47 to P40)

Port P4 is an 8-bit input/output port shared with serial interface input/output. This port is switched between input and output modes using the P4 port input/output control register (P4CR). When reset, the P4CR register is initialized to 0, with the P4 port set for input mode. Also, the output latch (P4DR) is initialized to 0 when reset.

The P4 port contains bitwise programmable open-drain control. The P4 port open-drain control register (P4ODE) is used to select open-drain or tri-state mode for the port. When reset, the P4ODE register is initialized to 0, with tri-state mode selected for the port.

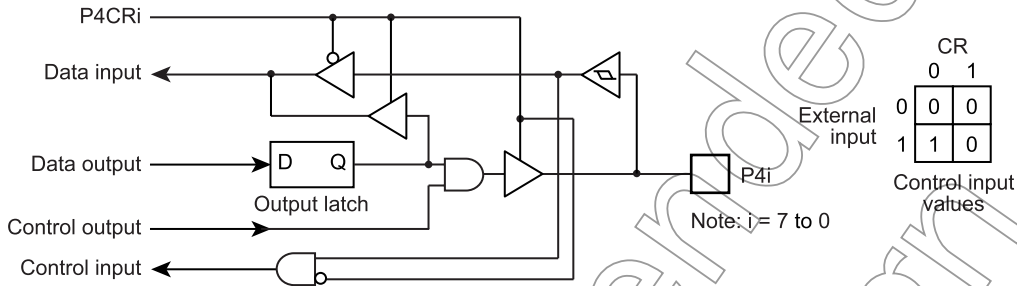

Figure 5-6 Port P4

#### P4 Port Input/Output Registers

	7	6	5	4	3	2	1	0	
P4DR (00004H)	P47 CTC	P46 PPG2	P45 SO TXD1	P44 SI RXD1	P43 SCK	P42 PDU1	P41 PDV1	P40 PDW1	(Initial value: 0000 0000)
P4CR (01F8AH)									(Initial value: 0000 0000)
P4CR	P4 port input/output control (Specify bitwise)						0: Input mode 1: Output mode		R/W
P4ODE (01F84H)									(Initial value: 0000 0000)
P4ODE	P4 port open-drain control (Specify bitwise)						0: Tri-state 1: Open drain		R/W

Note 1: Even when open-drain mode is selected, the protective diode remains connected. Therefore, do not apply voltages exceeding  $V_{DD}$ .

Note 2: Read-modify-write (RMW) operation executes at open-drain mode is selected, read out the output latch states. When any other instruction is executed, external pin states is read out.

Note 3: When using the 16-bit timer (CTC) as an ordinary timer, set P47 (CTC) for output mode.

## 5.6 Port P5 (P57 to P50)

Port P5 is an 8-bit input/output port. This port is switched between input and output modes using the P5 port input/output control register (P5CR). When reset, the P5CR register is initialized to 0, with the P5 port set for input mode. Also, the output latch (P5DR) is initialized to 0 when reset.

The P5 port contains bitwise programmable open-drain control. The P5 port open-drain control register (P5ODE) is used to select open-drain or tri-state mode for the port. When reset, the P5ODE register is initialized to 0, with tri-state mode selected for the port.

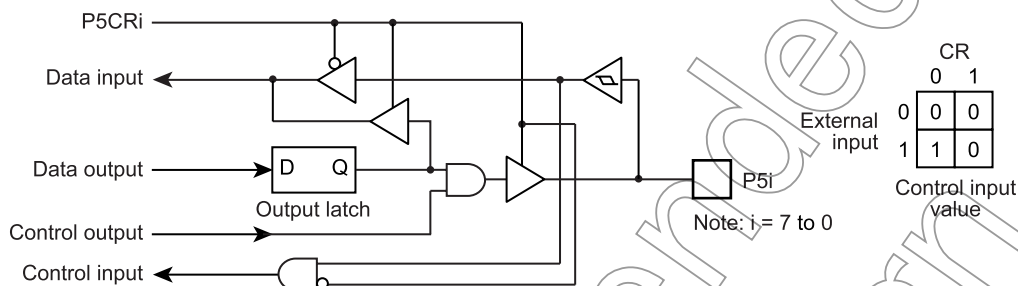

Figure 5-7 Port P5

### P5 Port Input/Output Registers

P5DR (00005H)	7	6	5	4	3	2	1	0	Read/Write (Initial value: 0000 0000)
	P57 Z2	P56 Y2	P55 X2	P54 W2	P53 V2	P52 U2	P51 EMG2	P50 CL2	

P5CR (01F8BH)	7	6	5	4	3	2	1	0	(Initial value: 0000 0000)

P5CR	P5 port input/output control (Specify bitwise)	0: Input mode 1: Output mode	R/W

P5ODE (01F85H)	7	6	5	4	3	2	1	0	(Initial value: 0000 0000)

P5ODE	P5 port open-drain control (Specify bitwise)	0: Tri-state 1: Open drain	R/W

Note 1: Even when open-drain mode is selected, the protective diode remains connected. Therefore, do not apply voltages exceeding  $V_{DD}$ .

Note 2: Read-modify-write (RMW) operation executes at open-drain mode is selected, read out the output latch states. When any other instruction is executed, external pin states is read out.

Note 3: For PMD circuit output, set the P5DR output latch to 1.

Note 4: When using P5 port as an input/output port, disable the EMG2 circuit.

### 5.7 Port P6 (P67 to P60)

Port P6 is an 8-bit input/output port shared with AD converter analog input. This port is switched between input and output modes using the P6 port input/output control register (P6CR), P6 port output latch (P6DR), and ADC-CRA<AINDS>. When reset, the P6CR Register and the P6DR output latch are initialized to 0 while ADC-CRA<AINDS> is set to 1, so that P67 to P60 have their inputs fixed low (= 0). When using the P6 port as an input port, set the corresponding bits for input mode (P6CR = 0, P6DR = 1). The reason why the output latch = 1 is because it is necessary to prevent current from flowing into the shared data input circuit. When using the port as an output port, set the P6CR Register's corresponding bits to 1. When using the port for analog input, set the corresponding bits for analog input (P6CR = 0, P6DR = 0). Then set ADCCRA<AINDS> = 0, and AD conversion will start.

The ports used for analog input must have their output latches set to 0 beforehand. The actual input channels for AD conversion are selected using ADCCRA<SAIN>.

Although the bits of P6 port not used for analog input can be used as input/output ports, do not execute output instructions on these ports during AD conversion. This is necessary to maintain the accuracy of AD conversion. Also, do not apply rapidly changing signals to ports adjacent to analog input during AD conversion.

If an input instruction is executed while the P6DR output latch is cleared to 0, data "0" is read in from said bits.

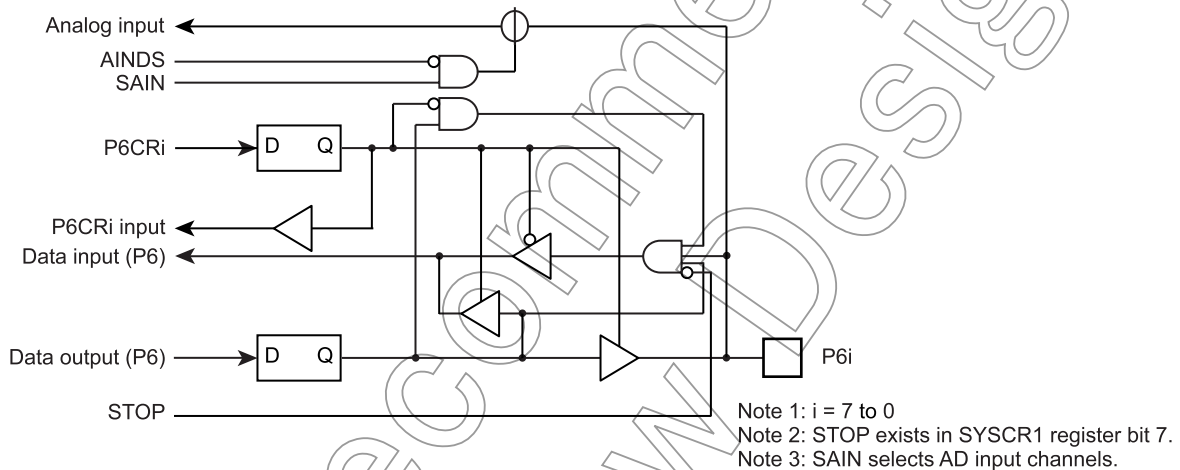

Figure 5-8 Port P6

## P6 Port Input/Output Registers

	7	6	5	4	3	2	1	0	
P6DR (00006H)	P67 AIN7 DBOUT1	P66 AIN6	P65 AIN5	P64 AIN4	P63 AIN3	P62 AIN2	P61 AIN1	P60 AIN0	Read/Write (Initial value: 0000 0000)
P6CR (01F8CH)	7	6	5	4	3	2	1	0	(Initial value: 0000 0000)

P6CR	P6 port input/output control (Specify bitwise)		AINDS = 1 (when not using AD)		AINDS = 0 (when using AD)		R/W
			P6DR = "0"	P6DR = "1"	P6DR = "0"	P6DR = "1"	
		0	Inputs fixed to 0	Input mode	Analog Input mode (Note2)	Input mode	
		1	Output mode				

Note 1: The pins used for analog input cannot be set for output mode (P6CR = 1) because they become shorted with external signals.

Note 2: When a read instruction is executed on bits of this port which are set for analog input mode, data "0" is read in.

Note 3: For DBOUT1 output, set the P6DR (P67) output latch to 1.

Note 4: When using this port in input mode (including analog input), do not use bit manipulating or other read-modify-write instructions. When a read instruction is executed on the bits of this port that are set for input, the contents of the pins are read in, so that if a read-modify-write instruction is executed, their output latches may be rewritten, making the pins unable to accept input. (A read-modify-write instruction first reads data from all of the eight bits and after modifying them (bit manipulation), writes data for all of the eight bits to the output latches.)

Not Recommended for New Design

### 5.8 Port P7 (P77 to P70)

Port P7 is an 8-bit input/output port shared with AD converter analog input. This port is switched between input and output modes using the P7 port input/output control register (P7CR), P7 port output latch (P7DR), and ADC-CRA<AINDS>. When reset, the P7CR register and the P7DR output latch are initialized to 0 while ADC-CRA<AINDS> is set to 1, so that P77 to P70 have their inputs fixed low (= 0). When using the P7 port as an input port, set the corresponding bits for input mode (P7CR = 0, P7DR = 1). The reason why the output latch = 1 is because it is necessary to prevent current from flowing into the shared data input circuit. When using the port as an output port, set the P7CR Register's corresponding bits to 1. When using the port for analog input, set the corresponding bits for analog input (P7CR = 0, P7DR = 0). Then set ADCCRA<AINDS> = 0, and AD conversion will start.

The ports used for analog input must have their output latches set to 0 beforehand. The actual input channels for AD conversion are selected using ADCCRA<SAIN>.

Although the bits of P7 port not used for analog input can be used as input/output ports, do not execute output instructions on these ports during AD conversion. This is necessary to maintain the accuracy of AD conversion. Also, do not apply rapidly changing signals to ports adjacent to analog input during AD conversion.

If an input instruction is executed while the P7DR output latch is cleared to 0, data "0" is read in from said bits.

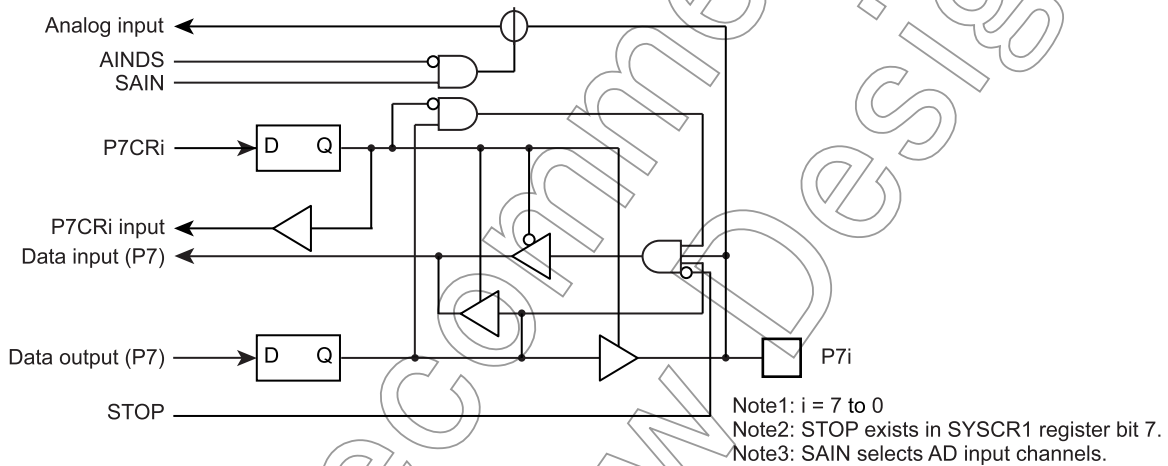

Figure 5-9 Port P7



## P7 Port Input/Output Registers

	7	6	5	4	3	2	1	0	
P7DR (00007H)	P77 AIN15 DBOUT2	P76 AIN14	P75 AIN13	P74 AIN12	P73 AIN11	P72 AIN10	P71 AIN9	P70 AIN8	Read/Write (Initial value: 0000 0000)
P7CR (01F8DH)	7	6	5	4	3	2	1	0	(Initial value: 0000 0000)

P7CR	P7 port input/output control (Specify bitwise)		AINDS = 1 (when not using AD)		AINDS = 0 (when using AD)		R/W
			P7DR = "0"	P7DR = "1"	P7DR = "0"	P7DR = "1"	
		0	Inputs fixed to 0	Input mode	Analog Input mode (Note2)	Input mode	
		1	Output mode				

Note 1: The pins used for analog input cannot be set for output mode (P7CR = 1) because they become shorted with external signals.

Note 2: When a read instruction is executed on bits of this port which are set for analog input mode, data "0" is read in.

Note 3: For DBOUT2 output, set the P7DR (P77) output latch to 1.

Note 4: When using this port in input mode (including analog input), do not use bit manipulating or other read-modify-write instructions. When a read instruction is executed on the bits of this port that are set for input, the contents of the pins are read in, so that if a read-modify-write instruction is executed, their output latches may be rewritten, making the pins unable to accept input. (A read-modify-write instruction first reads data from all of the eight bits and after modifying them (bit manipulation), writes data for all of the 8 bits to the output latches.)

Not Recommended for New Design

## 6. Time Base Timer (TBT) and Divider Output (DVO)

### 6.1 Time Base Timer

The time base timer generates time base for key scanning, dynamic displaying, etc. It also provides a time base timer interrupt (INTTBT).

An INTTBT ( Time Base Timer Interrupt ) is generated on the first falling edge of source clock ( The divider output of the timing generator which is selected by TBTCCK. ) after time base timer has been enabled.

The divider is not cleared by the program; therefore, only the first interrupt may be generated ahead of the set interrupt period ( Figure 6-2 ).

The interrupt frequency (TBTCCK) must be selected with the time base timer disabled (TBTEN="0"). (The interrupt frequency must not be changed with the disable from the enable state.) Both frequency selection and enabling can be performed simultaneously.

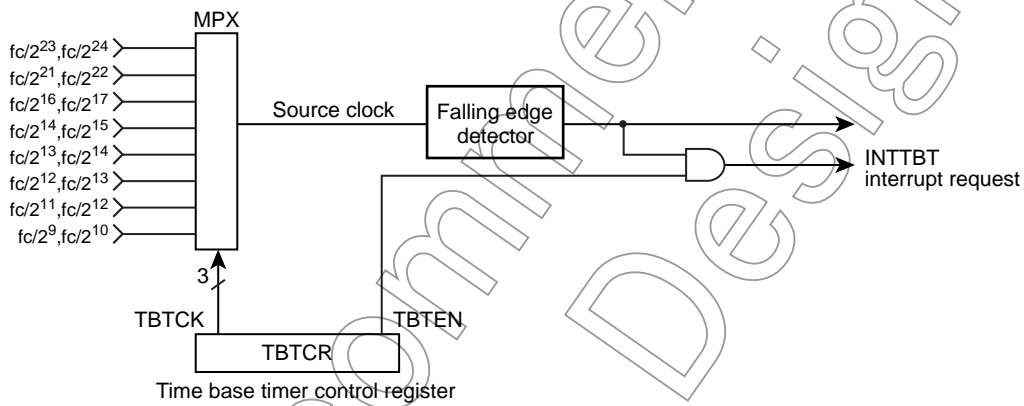

Figure 6-1 Time Base Timer configuration

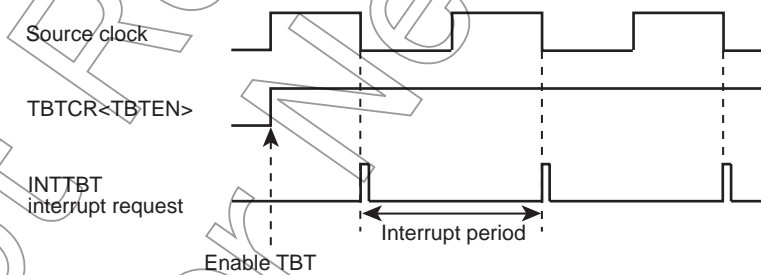

Figure 6-2 Time Base Timer Interrupt

Example :Set the time base timer frequency to  $fc/2^{16}$  [Hz] and enable an INTTBT interrupt.

```
LD      (TBTCR), 00000010B      ; TBTCCK ← 010 (Freq. set)
LD      (TBTCR), 00001010B      ; TBTEN ← 1 (TBT enable)
DI
SET     (EIRL), 6
EI
```

Time Base Timer is controlled by Time Base Timer control register (TBTCR).

Time Base Timer Control Register

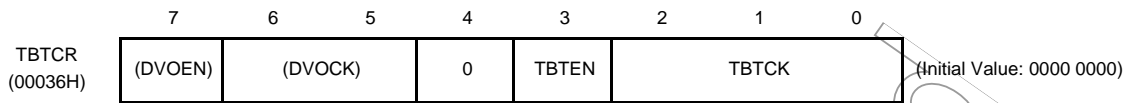

TBTEN	Time Base Timer Enable / Disable	0: Disable 1: Enable			
TBCK	Time Base Timer interrupt Frequency select : [Hz]	NORMAL, IDLE Mode		R/W	
		DV1CK=0			DV1CK=1
		000	$fc/2^{23}$		$fc/2^{24}$
		001	$fc/2^{21}$		$fc/2^{22}$
		010	$fc/2^{16}$		$fc/2^{17}$
		011	$fc/2^{14}$		$fc/2^{15}$
		100	$fc/2^{13}$		$fc/2^{14}$
		101	$fc/2^{12}$		$fc/2^{13}$
		110	$fc/2^{11}$		$fc/2^{12}$
111	$fc/2^9$	$fc/2^{10}$			

Note 1: fc; High-frequency clock [Hz], \*; Don't care

Note 2: Always set "0" in bit4 on TBTCR register.

Table 6-1 Time Base Timer Interrupt Frequency ( Example : fc = 20.0 MHz )

TBCK	Time Base Timer Interrupt Frequency [Hz]	
	NORMAL, IDLE Mode	
	DV1CK = 0	DV1CK = 1
000	2.38	1.20
001	9.53	4.78
010	305.18	153.50
011	1220.70	610.35
100	2441.40	1220.70
101	4882.83	2441.40
110	9765.63	4882.83
111	39063.00	19531.25

## 6.2 Divider Output ( $\overline{DVO}$ )

Approximately 50% duty pulse can be output using the divider output circuit, which is useful for piezoelectric buzzer drive. Divider output is from  $\overline{DVO}$  pin.

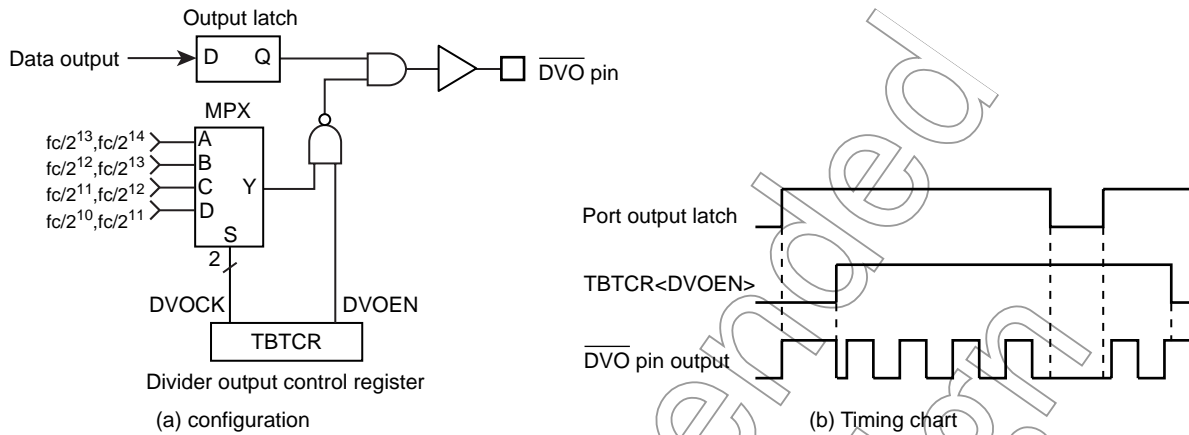

Figure 6-3 Divider Output

The Divider Output is controlled by the Time Base Timer Control Register (TBTCR).

### Time Base Timer Control Register

	7	6	5	4	3	2	1	0	
TBTCR (00036H)	DVOEN	DVOCK	"0"	(TBTEN)	(TBTCK)				(Initial value: 0000 0000)

DVOEN	Divider output enable / disable	0: Disable 1: Enable	NORMAL, IDLE Mode		R/W	
DVOCK	Divider Output ( $\overline{DVO}$ ) frequency selection: [Hz]		DV1CK=0	DV1CK=1	R/W	
			00	$fc/2^{13}$		$fc/2^{14}$
			01	$fc/2^{12}$		$fc/2^{13}$
			10	$fc/2^{11}$		$fc/2^{12}$
		11	$fc/2^{10}$	$fc/2^{11}$		

Note 1: Selection of divider output frequency (DVOCK) must be made while divider output is disabled (DVOEN="0"). Also, in other words, when changing the state of the divider output frequency from enabled (DVOEN="1") to disabled (DVOEN="0"), do not change the setting of the divider output frequency.

Note 2: In case of using  $\overline{DVO}$  output, set output mode by P1CR register after setting the related port output latch to "1" by P1DR register.

Note 3: fc; High-frequency clock [Hz], \*; Don't care

Note 4: Be sure to write "0" to TBTCR Register bit 4.

Example : 2.44 kHz pulse output ( $f_c = 20.0$  MHz)

Port setting

```
LD      (TBTCR) , 00000000B      ; DVOCK ← "00"
LD      (TBTCR) , 10000000B      ; DVOEN ← "1"
```

Table 6-2 Divider Output Frequency ( Example :  $f_c = 20.0$  MHz )

DVOCK	Divider Output Frequency [Hz]	
	NORMAL, IDLE Mode	
	DV1CK=0	DV1CK=1
00	2.4415 k	1.22075 k
01	4.8825 k	2.4415 k
10	9.765 k	4.8825 k
11	19.5325 k	9.765 k

Not Recommended for New Design

## 7. Watchdog Timer (WDT)

The watchdog timer is a fail-safe system to detect rapidly the CPU malfunctions such as endless loops due to spurious noises or the deadlock conditions, and return the CPU to a system recovery routine.

The watchdog timer signal for detecting malfunctions can be programmed only once as “reset request” or “pseudo nonmaskable interrupt request”. Upon the reset release, this signal is initialized to “reset request”.

When the watchdog timer is not used to detect malfunctions, it can be used as the timer to provide a periodic interrupt.

Note: Care must be taken in system design since the watchdog timer functions are not be operated completely due to effect of disturbing noise.

### 7.1 Watchdog Timer Configuration

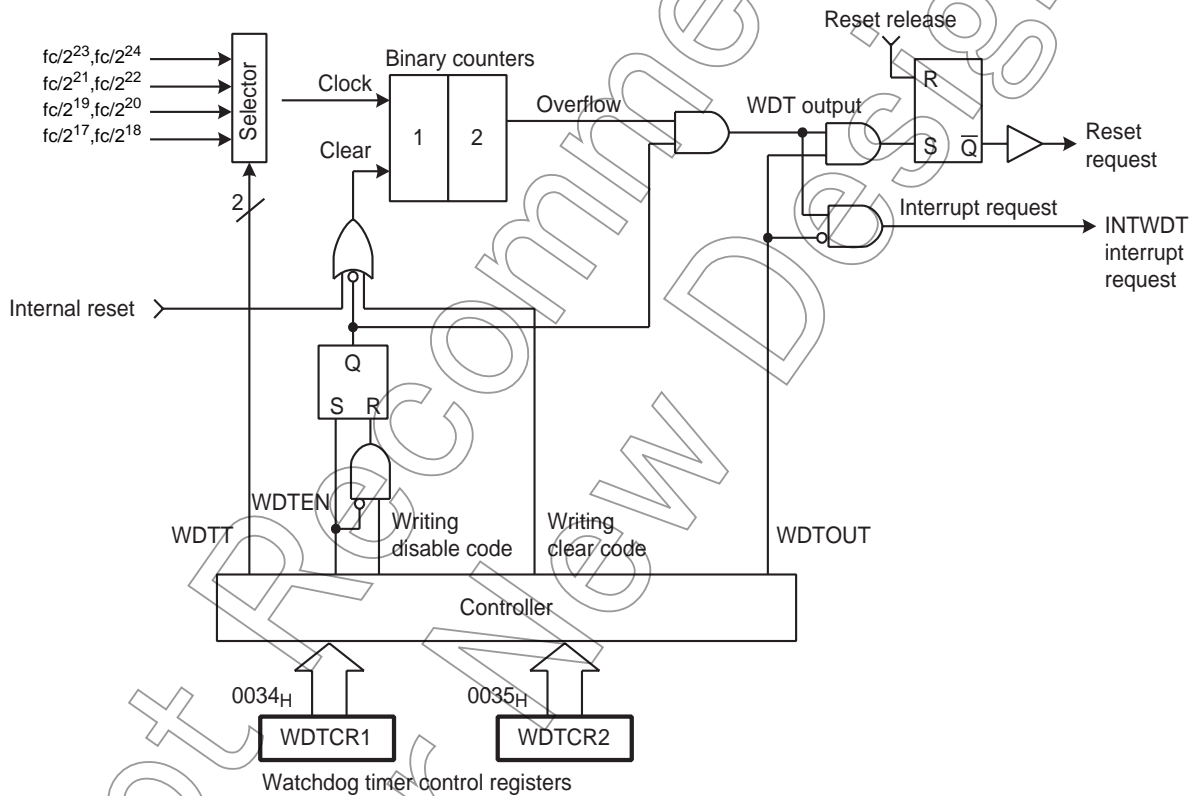

Figure 7-1 Watchdog Timer Configuration

## 7.2 Watchdog Timer Control

The watchdog timer is controlled by the watchdog timer control registers (WDTCR1 and WDTCR2). The watchdog timer is automatically enabled after the reset release.

### 7.2.1 Malfunction Detection Methods Using the Watchdog Timer

The CPU malfunction is detected, as shown below.

1. Set the detection time, select the output, and clear the binary counter.
2. Clear the binary counter repeatedly within the specified detection time.

If the CPU malfunctions such as endless loops or the deadlock conditions occur for some reason, the watchdog timer output is activated by the binary-counter overflow unless the binary counters are cleared. When WDTCR1<WDTOUT> is set to “1” at this time, the reset request is generated and then internal hardware is initialized. When WDTCR1<WDTOUT> is set to “0”, a watchdog timer interrupt (INTWDT) is generated.

The watchdog timer temporarily stops counting in the STOP mode including the warm-up or IDLE mode, and automatically restarts (continues counting) when the STOP/IDLE mode is inactivated.

Note: The watchdog timer consists of an internal divider and a two-stage binary counter. When the clear code 4EH is written, only the binary counter is cleared, but not the internal divider. The minimum binary-counter overflow time, that depends on the timing at which the clear code (4EH) is written to the WDTCR2 register, may be 3/4 of the time set in WDTCR1<WDTT>. Therefore, write the clear code using a cycle shorter than 3/4 of the time set to WDTCR1<WDTT>.

Example :Setting the watchdog timer detection time to  $2^{21}/fc$  [s], and resetting the CPU malfunction detection

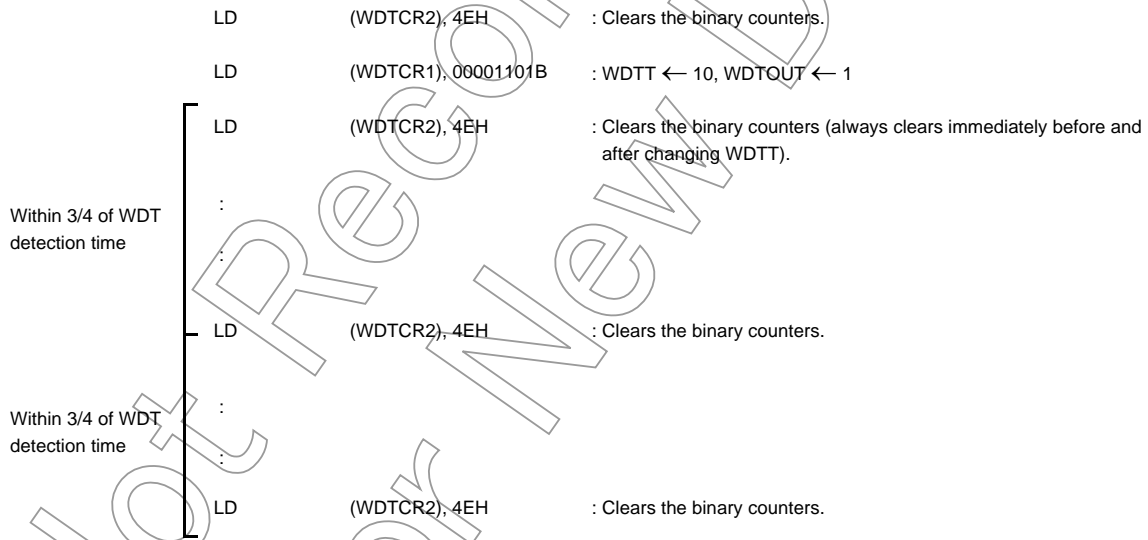

Watchdog Timer Control Register 1

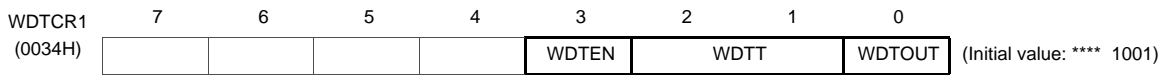

WDTEN	Watchdog timer enable/disable	0: Disable (Writing the disable code to WDTCR2 is required.) 1: Enable	Write only		
WDTT	Watchdog timer detection time [s]	NORMAL mode			
		00	$2^{25}/fc$	$2^{26}/fc$	Write only
		01	$2^{23}/fc$	$2^{24}/fc$	
		10	$2^{21}/fc$	$2^{22}/fc$	
		11	$2^{19}/fc$	$2^{20}/fc$	
WDTOUT	Watchdog timer output select	0: Interrupt request 1: Reset request	Write only		

- Note 1: After clearing WDTCR1<WDTOUT> to “0”, the program cannot set it to “1”.
- Note 2: fc: High-frequency clock [Hz], \*: Don't care
- Note 3: WDTCR1 is a write-only register and must not be used with any of read-modify-write instructions. If WDTCR1 is read, a unknown data is read.
- Note 4: To activate the STOP mode, disable the watchdog timer or clear the counter immediately before entering the STOP mode. After clearing the counter, clear the counter again immediately after the STOP mode is inactivated.
- Note 5: To clear WDTCR1<WDTEN>, set the register in accordance with the procedures shown in “7.2.3 Watchdog Timer Disable”.
- Note 6: If the watchdog timer is disabled during watchdog timer interrupt processing, the watchdog timer interrupt will never be cleared. Therefore, clear the watchdog timer ( set the clear code (4EH) to WDTCR2 ) before disabling it, or disable the watchdog timer a sufficient time before it overflows.
- Note 7: The watchdog timer consists of an internal divider, and a two-stage binary counter. When clear code (4EH) is written, only the binary counter is cleared, not the internal divider.  
Depending on the timing at which clear code (4EH) is written on the WDTCR2 register, the overflow time of the binary counter may be at minimum 3/4 of the time set in WDTCR1<WDTT>. Thus, write the clear code using a shorter cycle than 3/4 of the time set in WDTCR1<WDTT>.

Watchdog Timer Control Register 2

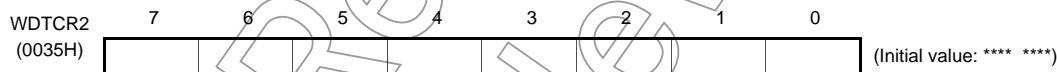

WDTCR2	Write Watchdog timer control code	4EH: Clear the watchdog timer binary counter (Clear code) B1H: Disable the watchdog timer (Disable code) Others: Invalid	Write only
--------	-----------------------------------	--	------------

- Note 1: The disable code is valid only when WDTCR1<WDTEN> = 0.
- Note 2: \*: Don't care
- Note 3: The binary counter of the watchdog timer must not be cleared by the interrupt task.
- Note 4: Write the clear code (4EH) using a cycle shorter than 3/4 of the time set in WDTCR1<WDTT>.
- Note 5: WDTCR2 is a write-only register and must not be used with any of read-modify-write instructions. If WDTCR2 is read, a unknown data is read.

7.2.2 Watchdog Timer Enable

Setting WDTCR1<WDTEN> to “1” enables the watchdog timer. Since WDTCR1<WDTEN> is initialized to “1” during reset, the watchdog timer is enabled automatically after the reset release.



### 7.2.3 Watchdog Timer Disable

To disable the watchdog timer, set the register in accordance with the following procedures. Setting the register in other procedures causes a malfunction of the microcontroller.

1. Set the interrupt master flag (IMF) to "0".
2. Set WDTCR2 to the clear code (4EH).
3. Set WDTCR1<WDTEN> to "0".
4. Set WDTCR2 to the disable code (B1H).

Note: While the watchdog timer is disabled, the binary counters of the watchdog timer are cleared.

Example :Disabling the watchdog timer

```

DI                                     : IMF ← 0
LD      (WDTCR2), 04EH                 : Clears the binary counter
LDW     (WDTCR1), 0B101H                : WDTEN ← 0, WDTCR2 ← Disable code
EI                                     : IMF ← 1
    
```

Table 7-1 Watchdog Timer Detection Time (Example:  $f_c = 20$  MHz)

WDTT	Watchdog Timer Detection Time[s]	
	NORMAL Mode	
	DV1CK = 0	DV1CK = 1
00	1.678	3.355
01	419.430 m	838.861 m
10	104.858 m	209.715 m
11	26.214 m	52.429 m

Note: If the watchdog timer is disabled during watchdog timer interrupt processing, the watchdog timer interrupt will never be cleared. Therefore, clear the watchdog timer ( set the clear code (4EH) to WDTCR2 ) before disabling it, or disable the watchdog timer a sufficient time before it overflows.

### 7.2.4 Watchdog Timer Interrupt (INTWDT)

When WDTCR1<WDTOUT> is cleared to "0", a watchdog timer interrupt request (INTWDT) is generated by the binary-counter overflow.

A watchdog timer interrupt is the non-maskable interrupt which can be accepted regardless of the interrupt master flag (IMF).

When a watchdog timer interrupt is generated while the other interrupt including a watchdog timer interrupt is already accepted, the new watchdog timer interrupt is processed immediately and the previous interrupt is held pending. Therefore, if watchdog timer interrupts are generated continuously without execution of the RETN instruction, too many levels of nesting may cause a malfunction of the microcontroller.

To generate a watchdog timer interrupt, set the stack pointer before setting WDTCR1<WDTOUT>.

Example :Setting watchdog timer interrupt

```
LD      SP, 08BFH      : Sets the stack pointer
LD      (WDTCR1), 00001000B : WDTOUT ← 0
```

### 7.2.5 Watchdog Timer Reset

When a binary-counter overflow occurs while WDTCR1<WDTOUT> is set to “1”, a watchdog timer reset request is generated. When a watchdog timer reset request is generated, the internal hardware is reset. The reset time is maximum  $24/f_c$  [s] ( max.  $1.2 \mu s$  @  $f_c = 20 \text{ MHz}$ ).

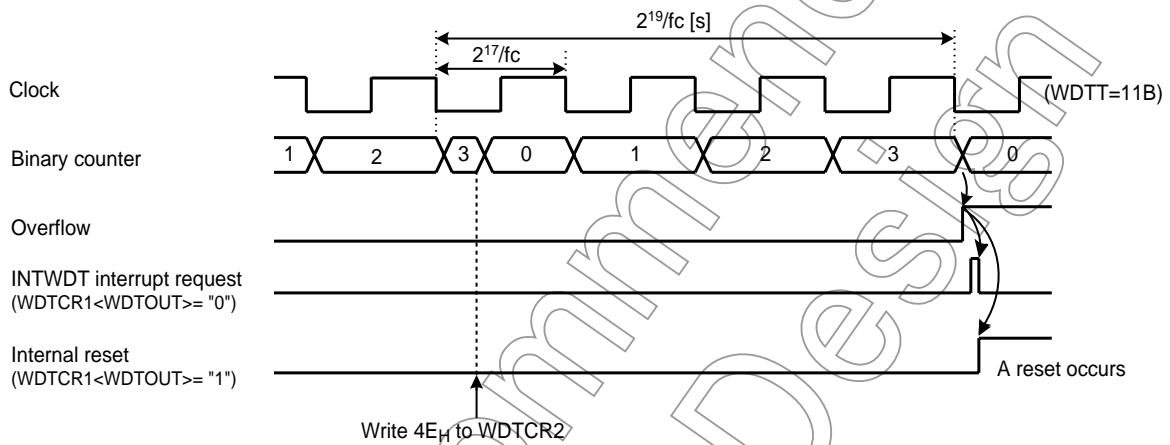

Figure 7-2 Watchdog timer Interrupt and Reset

Not Recommended for New Design

Not Recommended  
for New Design

# 8. 16-Bit TimerCounter 1 (TC1)

## 8.1 Configuration

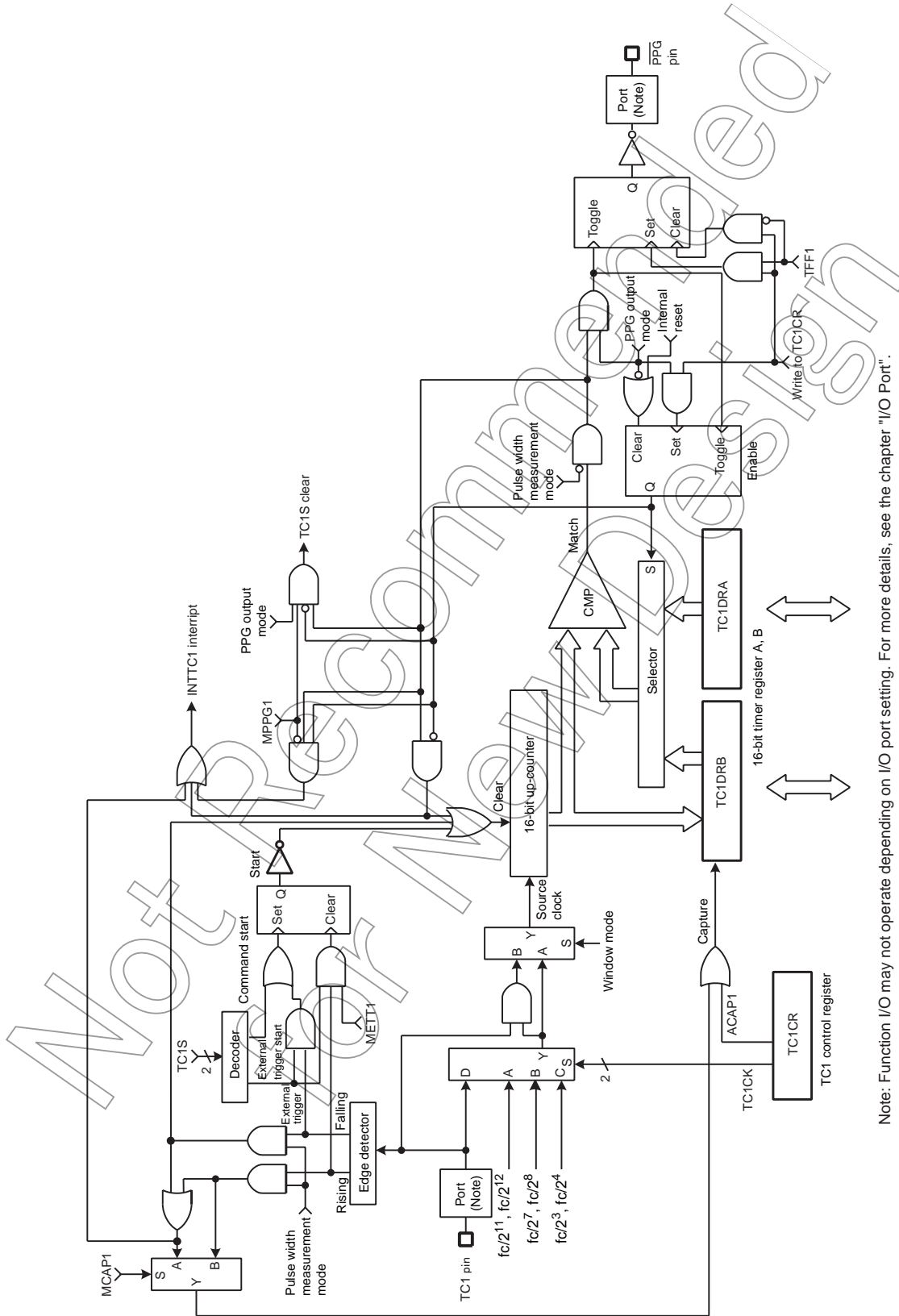

Note: Function I/O may not operate depending on I/O port setting. For more details, see the chapter "I/O Port".

Figure 8-1 TimerCounter 1 (TC1)



- Note 5: To set the timer registers, the following relationship must be satisfied.  
TC1DRA > TC1DRB > 1 (PPG output mode), TC1DRA > 1 (other modes)
- Note 6: Set TC1CR<TFF1> to "0" in the mode except PPG output mode.
- Note 7: Set TC1DRB after setting TC1CR<TC1M> to the PPG output mode.
- Note 8: When the STOP mode is entered, the start control (TC1CR<TC1S>) is cleared to "00" automatically, and the timer stops.  
After the STOP mode is exited, set the TC1CR<TC1S> to use the timer counter again.
- Note 9: Use the auto-capture function in the operative condition of TC1. A captured value may not be fixed if it's read after the execution of the timer stop or auto-capture disable. Read the capture value in a capture enabled condition.
- Note 10: Since the up-counter value is captured into TC1DRB by the source clock of up-counter after setting TC1CR<ACAP1> to "1". Therefore, to read the captured value, wait at least one cycle of the internal source clock before reading TC1DRB for the first time.

Not Recommended  
for New Design

## 8.3 Function

TimerCounter 1 has six types of operating modes: timer, external trigger timer, event counter, window, pulse width measurement, programmable pulse generator output modes.

### 8.3.1 Timer mode

In the timer mode, the up-counter counts up using the internal clock. When a match between the up-counter and the timer register 1A (TC1DRA) value is detected, an INTTC1 interrupt is generated and the up-counter is cleared. After being cleared, the up-counter restarts counting. Setting TC1CR<ACAP1> to “1” captures the up-counter value into the timer register 1B (TC1DRB) with the auto-capture function. Use the auto-capture function in the operative condition of TC1. A captured value may not be fixed if it's read after the execution of the timer stop or auto-capture disable. Read the capture value in a capture enabled condition. Since the up-counter value is captured into TC1DRB by the source clock of up-counter after setting TC1CR<ACAP1> to “1”. Therefore, to read the captured value, wait at least one cycle of the internal source clock before reading TC1DRB for the first time.

Table 8-1 Source Clock for TimerCounter 1 (Example:  $f_c = 20$  MHz)

TC1CK	NORMAL, IDLE Mode			
	DV1CK = 0		DV1CK = 1	
	Resolution [μs]	Maximum Time Setting [s]	Resolution [μs]	Maximum Time Setting [s]
00	102.4	6.7108	204.8	13.4216
01	6.4	0.4194	12.8	0.8388
10	0.5	26.214 m	0.8	52.428 m

Example 1 :Setting the timer mode with source clock  $f_c/2^{11}$  [Hz] and generating an interrupt 1 second later ( $f_c = 20$  MHz, CGCR<DV1CK> = “0”)

```
LDW    (TC1DRA), 2625H    ; Sets the timer register ( $1 \text{ s} \div 2^{11}/f_c = 2625\text{H}$ )
DI     ; IMF= "0"
SET    (EIRD), 2         ; Enables INTTC1
EI     ; IMF= "1"
LD     (TC1CR), 0000000B ; Selects the source clock and mode
```

```
LD     (TC1CR), 0001000B ; Starts TC1
```

Example 2 :Auto-capture

```
LD     (TC1CR), 0101000B ; ACAP1 ← 1
:     : ; Wait at least one cycle of the internal source clock
LD     WA, (TC1DRB)      ; Reads the capture value
```

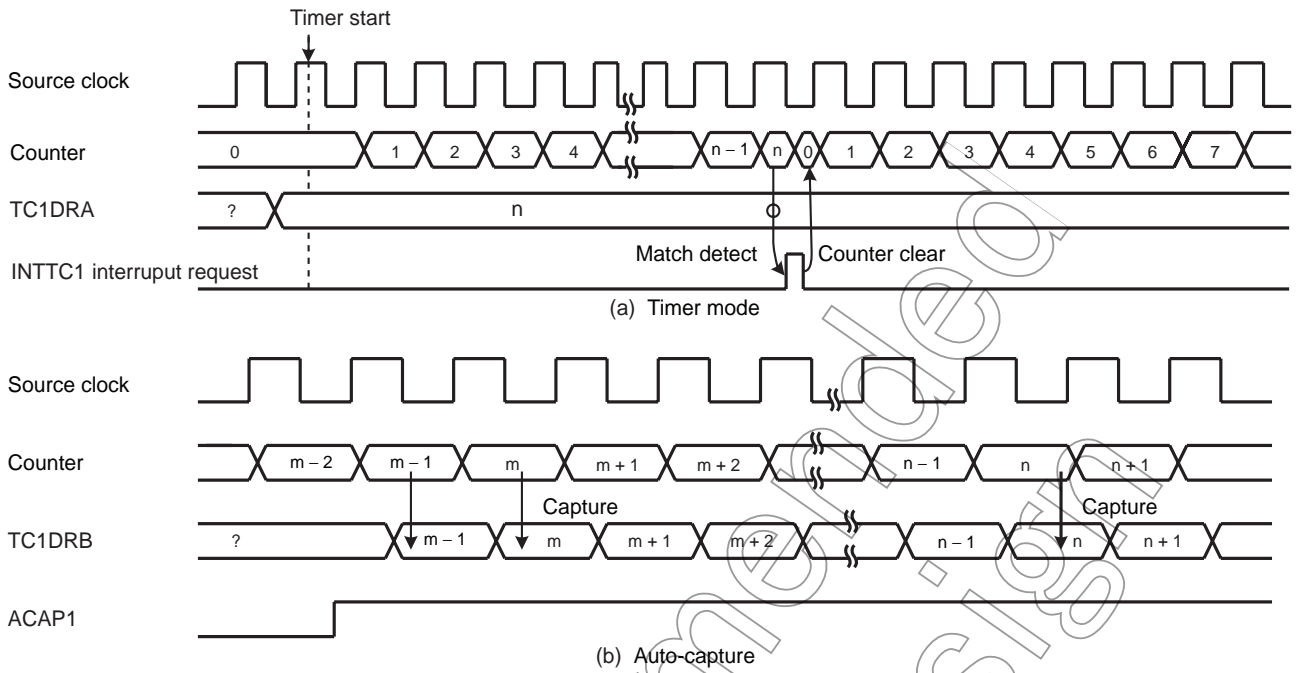

Figure 8-2 Timer Mode Timing Chart

Not Recommended for New Design



### 8.3.2 External Trigger Timer Mode

In the external trigger timer mode, the up-counter starts counting by the input pulse triggering of the TC1 pin, and counts up at the edge of the internal clock. For the trigger edge used to start counting, either the rising or falling edge is defined in TC1CR<TCIS>.

- When TC1CR<METT1> is set to “1” (trigger start and stop)

When a match between the up-counter and the TC1DRA value is detected after the timer starts, the up-counter is cleared and halted and an INTTC1 interrupt request is generated.

If the edge opposite to trigger edge is detected before detecting a match between the up-counter and the TC1DRA, the up-counter is cleared and halted without generating an interrupt request. Therefore, this mode can be used to detect exceeding the specified pulse by interrupt.

After being halted, the up-counter restarts counting when the trigger edge is detected.

- When TC1CR<METT1> is set to “0” (trigger start)

When a match between the up-counter and the TC1DRA value is detected after the timer starts, the up-counter is cleared and halted and an INTTC1 interrupt request is generated.

The edge opposite to the trigger edge has no effect in count up. The trigger edge for the next counting is ignored if detecting it before detecting a match between the up-counter and the TC1DRA.

Since the TC1 pin input has the noise rejection, pulses of  $4/f_c$  [s] or less are rejected as noise. A pulse width of  $12/f_c$  [s] or more is required to ensure edge detection.

Example 1 :Generating an interrupt 1 ms after the rising edge of the input pulse to the TC1 pin  
( $f_c = 20$  MHz, CGCR<DVICK> = “1”)

```
LDW      (TC1DRA), 007DH      ; 1ms ÷ 27/fc = 7DH
DI       ; IMF= “0”
SET      (EIRD), 2           ; Enables INTTC1 interrupt
EI       ; IMF= “1”
LD       (TC1CR), 00001000B   ; Selects the source clock and mode
LD       (TC1CR), 00111000B   ; Starts TC1 external trigger, METT1 = 0
```

Example 2 :Generating an interrupt when the low-level pulse with 4 ms or more width is input to the TC1 pin  
( $f_c = 20$  MHz, CGCR<DVICK> = “1”)

```
LDW      (TC1DRA), 0138H      ; 4 ms ÷ 28/fc = 0138H
DI       ; IMF= “0”
SET      (EIRD), 2           ; Enables INTTC1 interrupt
EI       ; IMF= “1”
LD       (TC1CR), 00000100B   ; Selects the source clock and mode
LD       (TC1CR), 01110100B   ; Starts TC1 external trigger, METT1 = 0
```

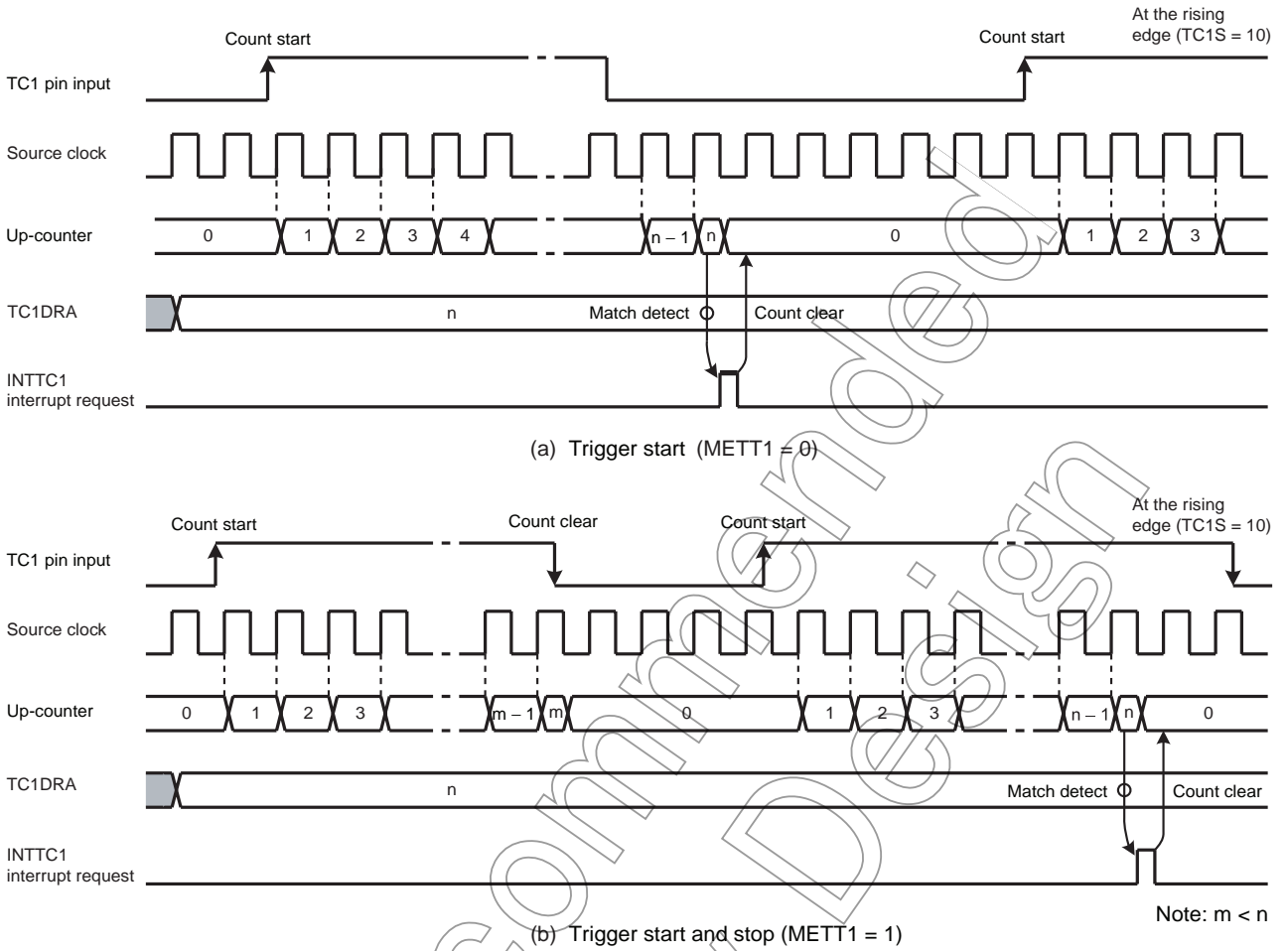

Figure 8-3 External Trigger Timer Mode Timing Chart

### 8.3.3 Event Counter Mode

In the event counter mode, the up-counter counts up at the edge of the input pulse to the TC1 pin. Either the rising or falling edge of the input pulse is selected as the count up edge in TC1CR<TC1S>.

When a match between the up-counter and the TC1DRA value is detected, an INTTC1 interrupt is generated and the up-counter is cleared. After being cleared, the up-counter restarts counting at each edge of the input pulse to the TC1 pin. Since a match between the up-counter and the value set to TC1DRA is detected at the edge opposite to the selected edge, an INTTC1 interrupt request is generated after a match of the value at the edge opposite to the selected edge.

Two or more machine cycles are required for the low-or high-level pulse input to the TC1 pin.

Setting TC1CR<ACAP1> to "1" captures the up-counter value into TC1DRB with the auto capture function. Use the auto-capture function in the operative condition of TC1. A captured value may not be fixed if it's read after the execution of the timer stop or auto-capture disable. Read the capture value in a capture enabled condition. Since the up-counter value is captured into TC1DRB by the source clock of up-counter after setting TC1CR<ACAP1> to "1". Therefore, to read the captured value, wait at least one cycle of the internal source clock before reading TC1DRB for the first time.

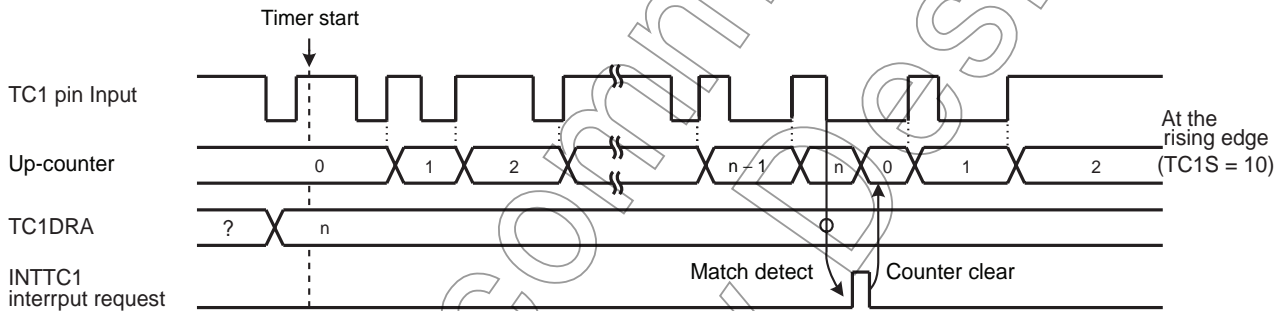

Figure 8-4 Event Counter Mode Timing Chart

Table 8-2 Input Pulth Width to TC1 Pin

	Minimum Pulse Width [s]
	NORMAL, IDLE Mode
High-going	$2^3/f_c$
Low-going	$2^3/f_c$

8.3.4 Window Mode

In the window mode, the up-counter counts up at the rising edge of the pulse that is logical ANDed product of the input pulse to the TC1 pin (window pulse) and the internal source clock. Either the positive logic (count up during high-going pulse) or negative logic (count up during low-going pulse) can be selected.

When a match between the up-counter and the TC1DRA value is detected, an INTTC1 interrupt is generated and the up-counter is cleared.

Define the window pulse to the frequency which is sufficiently lower than the internal source clock programmed with TC1CR<TC1CK>.

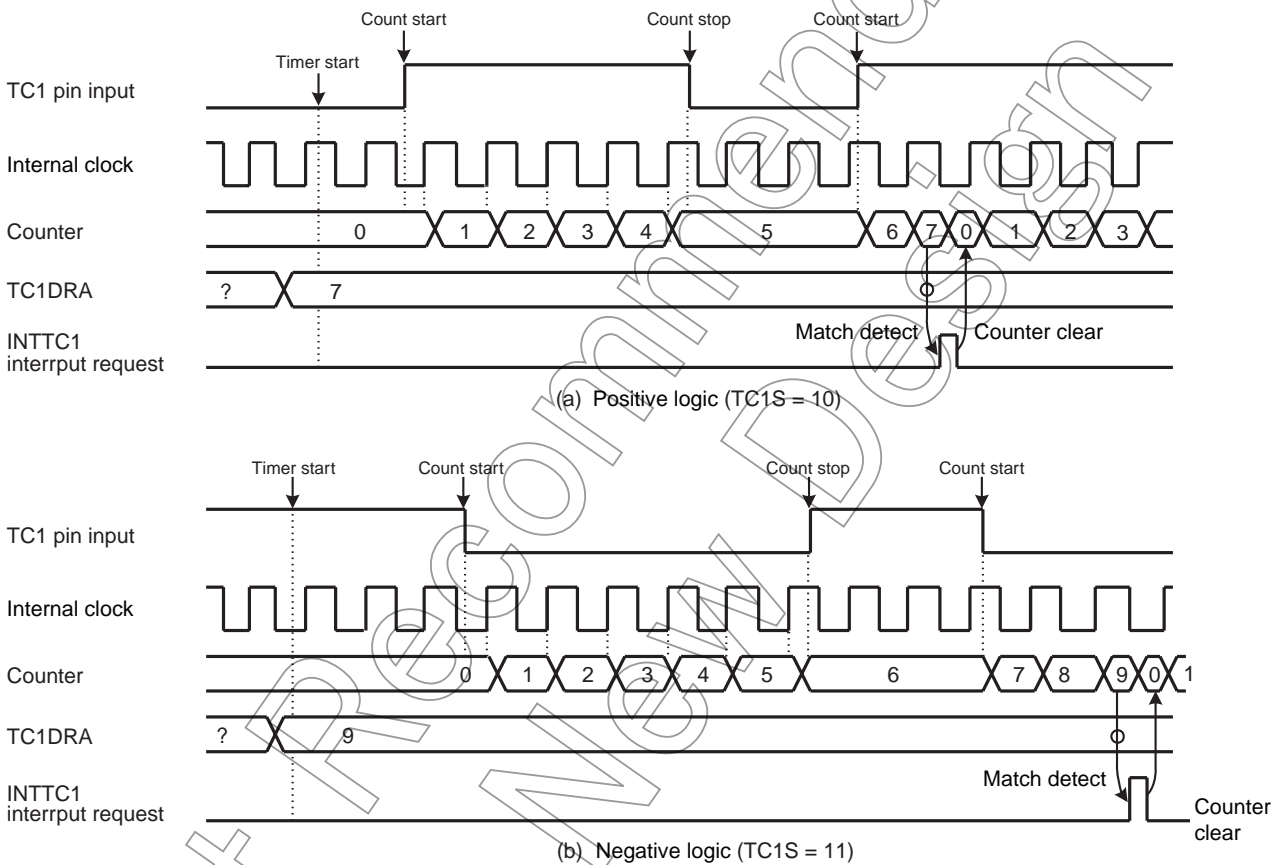

Figure 8-5 Window Mode Timing Chart

### 8.3.5 Pulse Width Measurement Mode

In the pulse width measurement mode, the up-counter starts counting by the input pulse triggering of the TC1 pin, and counts up at the edge of the internal clock. Either the rising or falling edge of the internal clock is selected as the trigger edge in TC1CR<TC1S>. Either the single- or double-edge capture is selected as the trigger edge in TC1CR<MCAP1>.

- When TC1CR<MCAP1> is set to “1” (single-edge capture)

Either high- or low-level input pulse width can be measured. To measure the high-level input pulse width, set the rising edge to TC1CR<TC1S>. To measure the low-level input pulse width, set the falling edge to TC1CR<TC1S>.

When detecting the edge opposite to the trigger edge used to start counting after the timer starts, the up-counter captures the up-counter value into TC1DRB and generates an INTTC1 interrupt request. The up-counter is cleared at this time, and then restarts counting when detecting the trigger edge used to start counting.

- When TC1CR<MCAP1> is set to “0” (double-edge capture)

The cycle starting with either the high- or low-going input pulse can be measured. To measure the cycle starting with the high-going pulse, set the rising edge to TC1CR<TC1S>. To measure the cycle starting with the low-going pulse, set the falling edge to TC1CR<TC1S>.

When detecting the edge opposite to the trigger edge used to start counting after the timer starts, the up-counter captures the up-counter value into TC1DRB and generates an INTTC1 interrupt request. The up-counter continues counting up, and captures the up-counter value into TC1DRB and generates an INTTC1 interrupt request when detecting the trigger edge used to start counting. The up-counter is cleared at this time, and then continues counting.

Note 1: The captured value must be read from TC1DRB until the next trigger edge is detected. If not read, the captured value becomes a don't care. It is recommended to use a 16-bit access instruction to read the captured value from TC1DRB.

Note 2: For the single-edge capture, the counter after capturing the value stops at “1” until detecting the next edge. Therefore, the second captured value is “1” larger than the captured value immediately after counting starts.

Note 3: The first captured value after the timer starts may be read incorrectly, therefore, ignore the first captured value.

Example :Duty measurement (resolution  $fc/2^7$  [Hz], CGCR<DV1CK> = "0")

```

CLR      (INTTC1SW). 0      ; INTTC1 service switch initial setting
                          ; Address set to convert INTTC1SW at each INTTC1

LD       (TC1CR), 00000110B ; Sets the TC1 mode and source clock
DI       ; IMF= "0"
SET      (EIRD). 2         ; Enables INTTC1
EI       ; IMF= "1"
LD       (TC1CR), 00100110B ; Starts TC1 with an external trigger at MCAP1 = 0
:
PINTTC1: CPL      (INTTC1SW). 0 ; INTTC1 interrupt, inverts and tests INTTC1 service switch
          JRS      F, SINTTC1
          LD       A, (TC1DRBL) ; Reads TC1DRB (High-level pulse width)
          LD       W,(TC1DRBH)
          LD       (HPULSE), WA ; Stores high-level pulse width in RAM
          RETI
SINTTC1: LD       A, (TC1DRBL) ; Reads TC1DRB (Cycle)
          LD       W,(TC1DRBH)
          LD       (WIDTH), WA ; Stores cycle in RAM
          :
          RETI ; Duty calculation
          :
VINTTC1: DW       PINTTC1 ; INTTC1 Interrupt vector
    
```

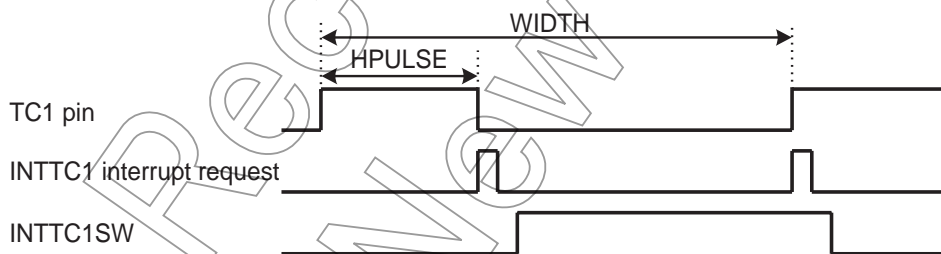

Not Recommended for New Design

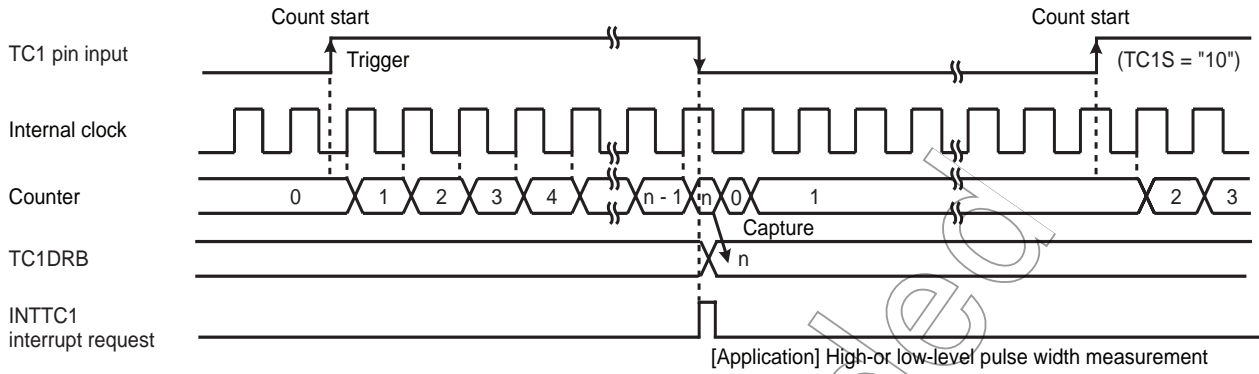

(a) Single-edge capture (MCAP1 = "1")

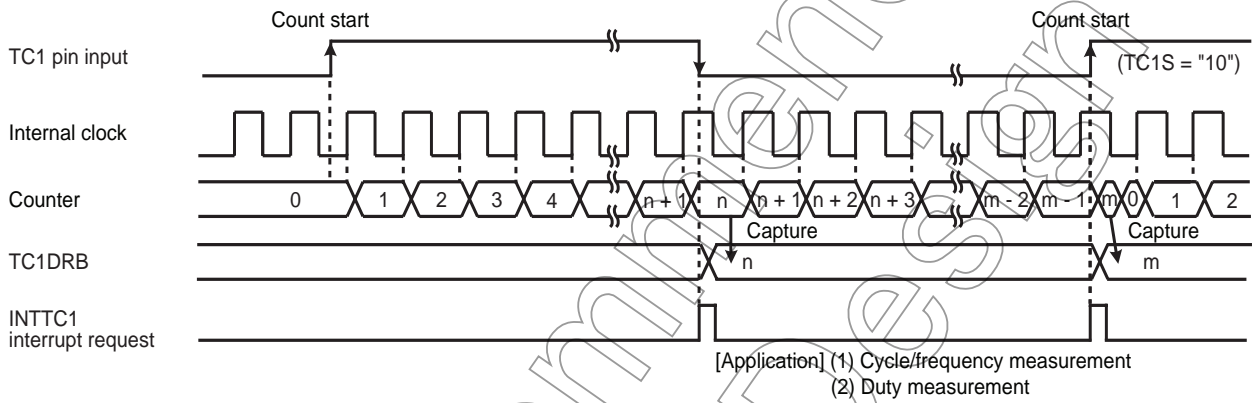

(b) Double-edge capture (MCAP1 = "0")

Figure 8-6 Pulse Width Measurement Mode

Not Recommended for New Designs

### 8.3.6 Programmable Pulse Generate (PPG) Output Mode

In the programmable pulse generation (PPG) mode, an arbitrary duty pulse is generated by counting performed in the internal clock. To start the timer, TC1CR<TC1S> specifies either the edge of the input pulse to the TC1 pin or the command start. TC1CR<MPPG1> specifies whether a duty pulse is produced continuously or not (one-shot pulse).

- When TC1CR<MPPG1> is set to “0” (Continuous pulse generation)

When a match between the up-counter and the TC1DRB value is detected after the timer starts, the level of the  $\overline{\text{PPG}}$  pin is inverted and an INTTC1 interrupt request is generated. The up-counter continues counting. When a match between the up-counter and the TC1DRA value is detected, the level of the  $\overline{\text{PPG}}$  pin is inverted and an INTTC1 interrupt request is generated. The up-counter is cleared at this time, and then continues counting and pulse generation.

When TC1CR<TC1S> is cleared to “00” during PPG output, the  $\overline{\text{PPG}}$  pin retains the level immediately before the counter stops.

- When TC1CR<MPPG1> is set to “1” (One-shot pulse generation)

When a match between the up-counter and the TC1DRB value is detected after the timer starts, the level of the  $\overline{\text{PPG}}$  pin is inverted and an INTTC1 interrupt request is generated. The up-counter continues counting. When a match between the up-counter and the TC1DRA value is detected, the level of the  $\overline{\text{PPG}}$  pin is inverted and an INTTC1 interrupt request is generated. TC1CR<TC1S> is cleared to “00” automatically at this time, and the timer stops. The pulse generated by PPG retains the same level as that when the timer stops.

Since the output level of the  $\overline{\text{PPG}}$  pin can be set with TC1CR<TFF1> when the timer starts, a positive or negative pulse can be generated. Since the inverted level of the timer F/F1 output level is output to the  $\overline{\text{PPG}}$  pin, specify TC1CR<TFF1> to “0” to set the high level to the  $\overline{\text{PPG}}$  pin, and “1” to set the low level to the  $\overline{\text{PPG}}$  pin. Upon reset, the timer F/F1 is initialized to “0”.

Note 1: To change TC1DRA or TC1DRB during a run of the timer, set a value sufficiently larger than the count value of the counter. Setting a value smaller than the count value of the counter during a run of the timer may generate a pulse different from that specified.

Note 2: Do not change TC1CR<TFF1> during a run of the timer. TC1CR<TFF1> can be set correctly only at initialization (after reset). When the timer stops during PPG, TC1CR<TFF1> can not be set correctly from this point onward if the PPG output has the level which is inverted of the level when the timer starts. (Setting TC1CR<TFF1> specifies the timer F/F1 to the level inverted of the programmed value.) Therefore, the timer F/F1 needs to be initialized to ensure an arbitrary level of the PPG output. To initialize the timer F/F1, change TC1CR<TC1M> to the timer mode (it is not required to start the timer mode), and then set the PPG mode. Set TC1CR<TFF1> at this time.

Note 3: In the PPG mode, the following relationship must be satisfied.

$$\text{TC1DRA} > \text{TC1DRB}$$

Note 4: Set TC1DRB after changing the mode of TC1M to the PPG mode.



Example :Generating a pulse which is high-going for 800  $\mu$ s and low-going for 200  $\mu$ s  
( $f_c = 20$  MHz,  $CGCR\langle DV1CK \rangle = "0"$ )

Setting port		
LD	(TC1CR), 10001011B	; Sets the PPG mode, selects the source clock
LDW	(TC1DRA), 04E2H	; Sets the cycle ( $1 \text{ ms} \div 2^4/f_c \mu\text{s} = 04E2\text{H}$ )
LDW	(TC1DRB), 00FAH	; Sets the low-level pulse width ( $200 \mu\text{s} \div 2^4/f_c = 00FA\text{H}$ )
LD	(TC1CR), 10010111B	; Starts the timer

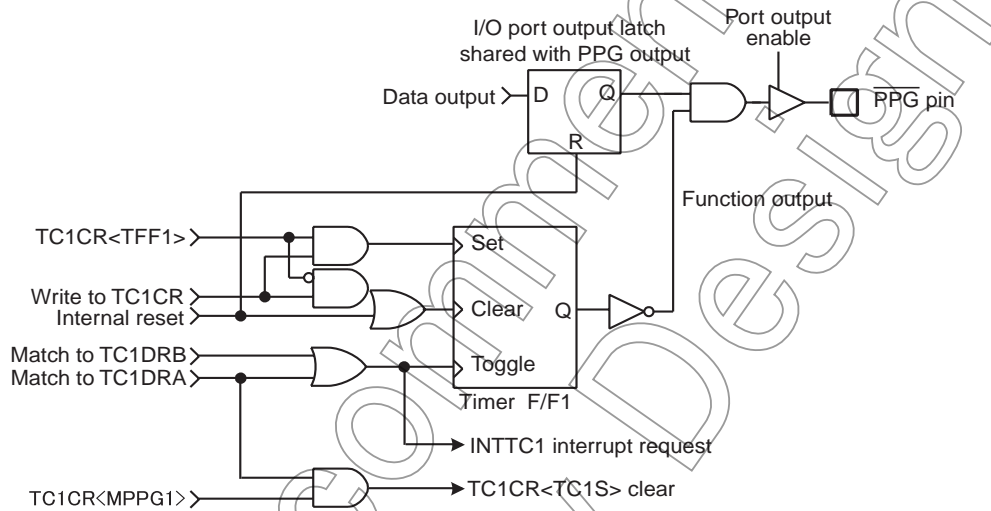
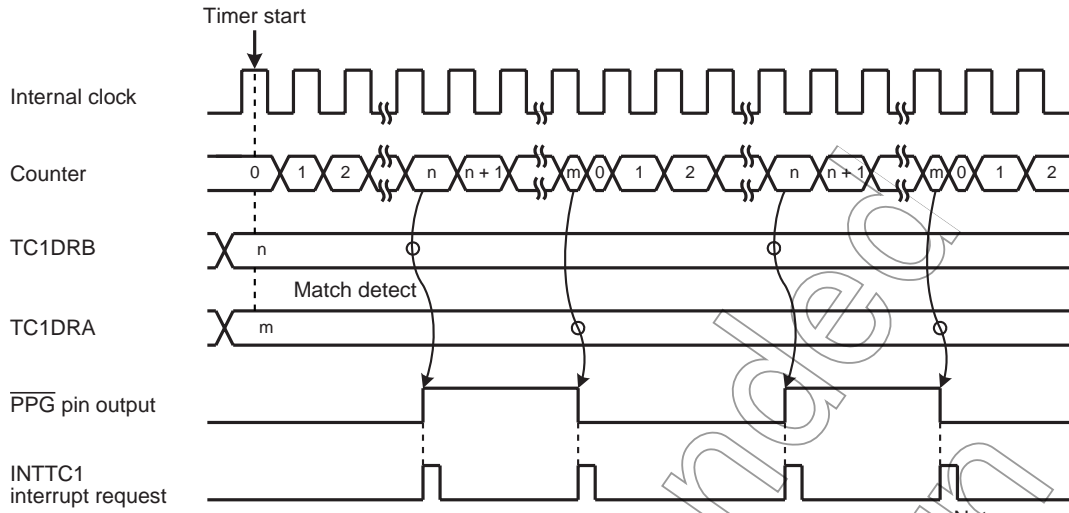
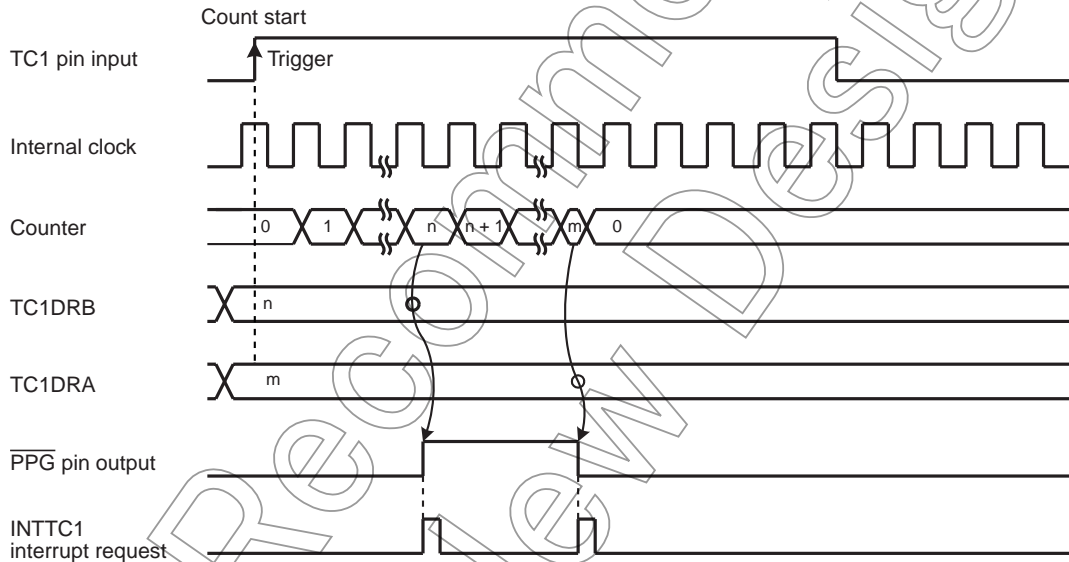

Figure 8-7 PPG Output



(a) Continuous pulse generation (TC1S = 01)



[Application] One-shot pulse output

(b) One-shot pulse generation (TC1S = 10)

Note:  $m > n$

Figure 8-8 PPG Mode Timing Chart

Not for

Not Recommended  
for New Design

# 9. 16-Bit Timer (CTC)

## 9.1 Configuration

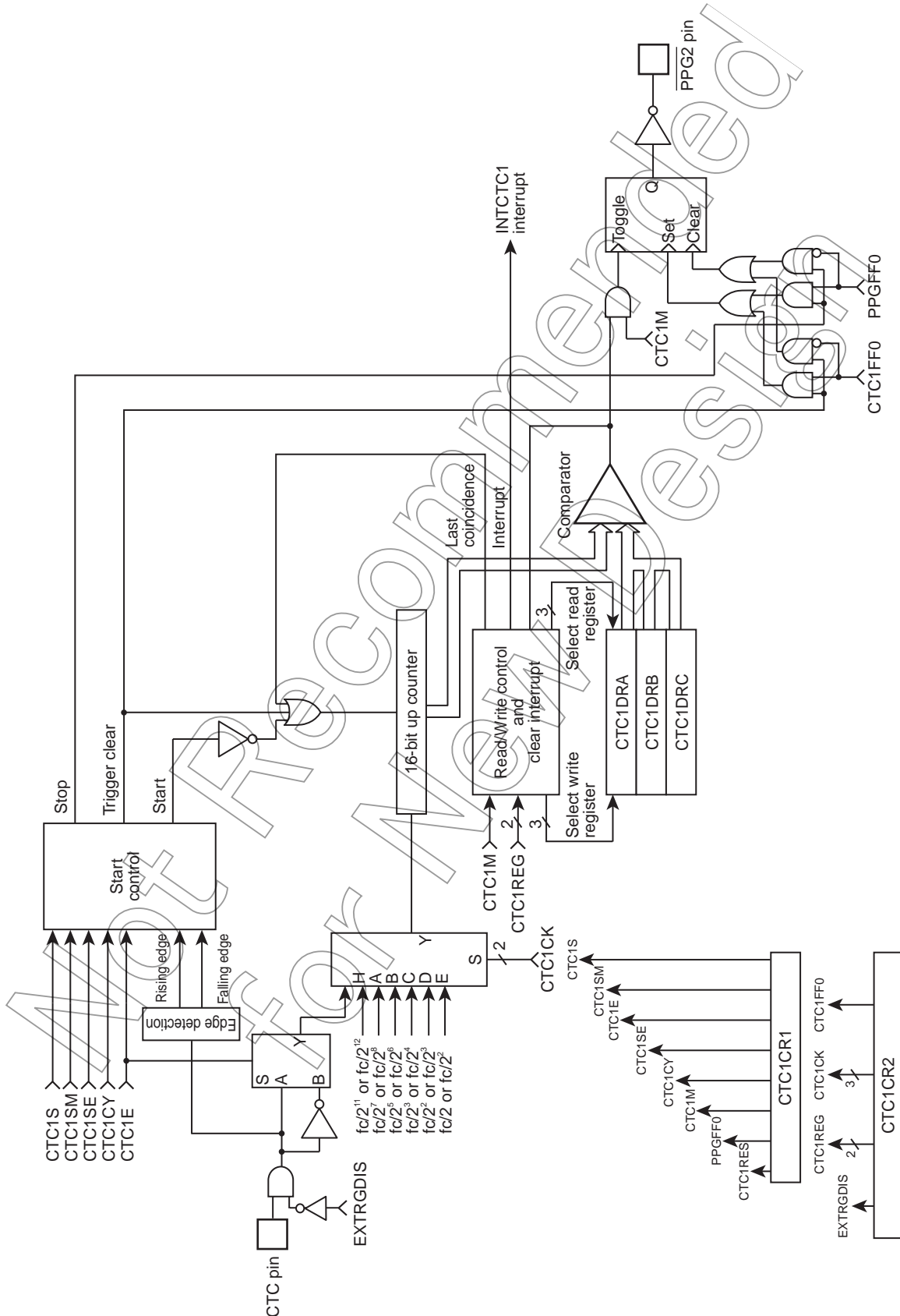

Figure 9-1 CTC Block Diagram

## 9.2 Control

Compare timer/counter 1 is controlled using Compare timer/counter 1 Control Registers (CTC1CR1 and CTC1CR2), as well as three 16-bit Timer Registers (CTC1DRA, CTC1DRB, and CTC1DRC).

### Compare Timer Registers (CTC1DRH: 00017h, CTC1DRL: 00016h)

CTC1DRA	15	14	13	12	11	10	9	8	7	6	5	4	3	2	1	0	Write only (Initial value: ***** *)
	CTC1DRAH								CTC1DRAL								
CTC1DRB	15	14	13	12	11	10	9	8	7	6	5	4	3	2	1	0	Write only (Initial value: ***** *)
	CTC1DRBH								CTC1DRBL								
CTC1DRC	15	14	13	12	11	10	9	8	7	6	5	4	3	2	1	0	Write only (Initial value: ***** *)
	CTC1DRCH								CTC1DRCL								

Note: CTC1DRA, CTC1DRB, and CTC1DRC are write-only registers and must not be used with any of the read-modify-write instructions such as SET, CLR, etc.

### Compare Timer/Counter 1 Control Registers (CTC1CR2: 00015h, CTC1CR1: 00014h)

CTC1CR1 lower address	7	6	5	4	3	2	1	0	R/W (Initial value: 00000000)
	CTC1RES	PPGFF0	CTC1M	CTC1CY	CTC1SE	CTC1E	CTC1SM	CTC1S	
CTC1CR2 upper address	7	6	5	4	3	2	1	0	R/W (Initial value: *0000000)
	*	EXTRG-DIS	CTC1REG		CTC1CK		CTC1FF0		

Note 1: \*: Don't care

Note 2: The CTC1CR1<CTC1RES> is 0 when read.

Note 3: Use the LDW instruction for write to the CTC1DR H/L Registers. Set a value equal to or greater than 2.

Note 4: Write to CTC1DR H/L A, B, and C Registers as many as set with the CTC1CR2 Register CTC1REG bit.

Note 5: Data are written to CTC1DR H/L Registers in order of CTC1DRA, CTC1DRB, and CTC1DRC.

Not Recommended for New Designs

### Setting-up the CTC1CR1 Register

Register	Field	Description	Timer	Event	PPG	
CTC1S	Control start	0: Stop and clear counter 1: Command start	o	o	o	R/W
			o	o	o	
CTC1SM	Select start	0: Software start 1: External trigger start	o	o	o	
			o	x	o	
CTC1E	Select external trigger edge	0: Enable one edge 1: Enable both edges	o	o	o	
			o	x	o	
CTC1SE	Select external trigger start edge	0: Rising edge 1: Falling edge	o	o	o	
			o	o	o	
CTC1CY	Select cycle	0: Successive 1: One shot	o	o	o	
			o	x	o	
CTC1M	Set operation mode	0: Timer/Event counter modes 1: PPG (programmable pulse generator) output mode				
PPGFF0	Select PPG output	0: Forward output immediately after start 1: Reverse output immediately after start				
CTC1RES	Reset all	0: Normal operation 1: CTC1 reset				

### Setting-up the CTC1CR2 Register

Register	Field	Description	NORMAL and IDLE Modes						
CTC1FF0	Control timer output F/F0	0: Clear 1: Set	DV1CK = 0	DV1CK = 1	Timer	Event	PPG	R/W	
			000	fc/2 <sup>11</sup>	fc/2 <sup>12</sup>	o	-		x
			001	fc/2 <sup>7</sup>	fc/2 <sup>8</sup>	o	-		x
			010	fc/2 <sup>5</sup>	fc/2 <sup>6</sup>	o	-		x
			011	fc/2 <sup>3</sup>	fc/2 <sup>4</sup>	o	-		x
			100	fc/2 <sup>2</sup>	fc/2 <sup>3</sup>	o	-		o <sup>Note3</sup>
			101	fc/2	fc/2 <sup>2</sup>	o	-		o
			110	-	-	x	x		x
			111	External clock input (CTC1 pin input)		-	o		x
CTC1REG	Set registers used by timer/counter	00: CTC1DRA 01: CTC1DRA + CTC1DRB 10: CTC1DRA + CTC1DRB + CTC1DRC 11: Reserved	1REG 2REG 3REG						
EXTRGDIS	External trigger input <sup>Note4</sup>	0: Enable external trigger input 1: Disable external trigger input							

Note 1: fc: Clock [Hz]

Note 2: Make sure the timer/counter is idle (CTC1CR1<CTC1SM, CTC1S> = 00) before setting operation mode, edge, start, source clock, external trigger timer mode control, and PPG output control.

Note 3: When DV1CK=1, CTC1CR2<CTC1CK>=100 cannot be used.

Note 4: When CTC1 input is not used in the CTC1 timer, external trigger input must be disabled (CTC1CR2<EXTRGDIS> = 1) regardless of the selected mode.

Note 5: The CTC1DRB and CTC1DRC Registers cannot be accessed for write unless they are set for PPG output mode and specified with CTC1CR2<CTC1REG>.

Note 6: CTC1CR1<CTC1E> is effective only when using an external clock as trigger (CTC1CR1<CTC1SM>).

Note 7: Data must be written to as many data registers as set with CTC1CR2<CTC1REG>.

Note 8: To write data to CTC1DRA/B/C, use the LDW instruction, or use the LD instruction writing in order of L, H.

Note 9: Data register values must be written to the respective registers before starting. To modify the values after starting, write the new data within an interval from an INTCTC1 interrupt to the next INTCTC1.

Note 10: Specifying CTC1CR1<CTC1RES> = 1 causes all conditions to be reset. Even when the CTC circuit is operating, they are reset, and the PPG output becomes "0". However, only the INTCTC1 signal is not reset if the signal is being generated.

Note 11: For event counter mode (when CTC pin input is selected in timer mode), the active edge of the external trigger to count can be selected with CTC1CR1<CTC1SE>.

Note 12: Disabling external trigger input with CTC1CR2<EXTRGDIS> creates the 0 input state.

Note 13: To stop the counter by software at trigger start, set CTC1CR2<CTC1SM, CTC1S> = 00.

Note 14: The number of registers set and the values set in the timer registers must meet the conditions shown below.

Number of Registers		Timer Register Value Conditions
CTC1REG	1 Register	$CTC1DRA \geq 2$
	2 Register	$CTC1DRB > CTC1DRA + 1$ , and $CTC1DRA \geq 2$
	3 Register	$CTC1DRC > CTC1DRB + 1$ , $CTC1DRB > CTC1DRA + 1$ , and $CTC1DRA \geq 2$

Not Recommended for New Design

### 9.3 Function

Compare timer/counter 1 has three modes: timer, event counter, and programmable pulse generator output modes.

#### 9.3.1 Timer mode with software start

In this mode, the timer/counter (16-bit counter) counts up synchronously with the internal clock. When the counter value and the set value of Compare Timer Register 1A (CTC1DRA) match, an INTCTC1 interrupt is generated and the counter is cleared. After the counter is cleared, it restarts and continues counting up.

Table 9-1 Internal Clock Source for Compare Timer/Counter 1 (Example: fc = 20 MHz)

CTC1CK	NORMAL and IDLE Modes			
	DV1CK = 0		DV1CK = 1	
	Resolution [ $\mu$ s]	Maximum Setting Time [s]	Resolution [ $\mu$ s]	Maximum Setting Time [s]
000	102.4	6.71	204.8	13.42
001	6.4	0.419	12.8	0.839
010	1.6	0.105	3.2	0.210
011	0.4	26.21 m	0.8	52.43 m
100	0.2	13.11 m	0.4	26.21 m
101	0.1	6.55 m	0.2	13.11 m
110	-	-	-	-

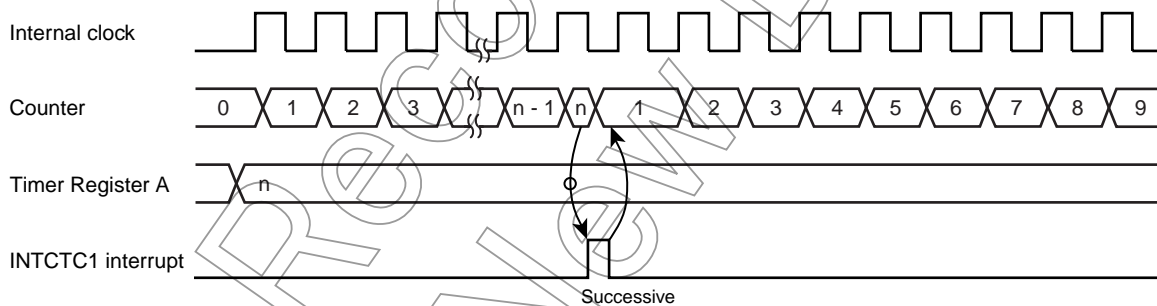

Figure 9-2 Timer Mode Timing Chart

Note: If the CTC input port (P47) is set for input mode, the timer/counter is reset by an input edge on port. When using the timer/counter as an ordinary timer, set CTC1CR2<EXTRGDIS> to 1 or set P47 for output mode.



### 9.3.2 Timer mode with external trigger start

In this timer mode, the timer/counter starts counting as triggered by input on CTC pin (rising or falling edge selected with CTC1CR1<CTC1SE>). The source clock is an internal clock. For successive cycles, when the counter value and the set value of the CTC1DRA Register match, an INTCTC1 interrupt is generated and the counter is cleared and then restarted. The counter is stopped by a trigger input on CTC pin and restarted by the next trigger input. For a one-shot cycle, when the counter value and the set value of the CTC1DRA Register match, an INTCTC1 interrupt is generated and the counter is cleared and stopped. The counter restarts counting up by input on CTC pin. When CTC1CR1<CTC1E> = 1, the counter is cleared and stops counting at an edge on CTC pin input opposite the active edge that triggers the counter to start counting. In this mode, an interrupt can be generated by entering a pulse which has a certain width. When CTC1CR1<CTC1E> = 0, opposite edges on CTC input are ignored.

(l) When rising edge start is selected, with counting enabled on one edge  
( CTC1SE = 0, CTC1E = 0 )

a) Successive

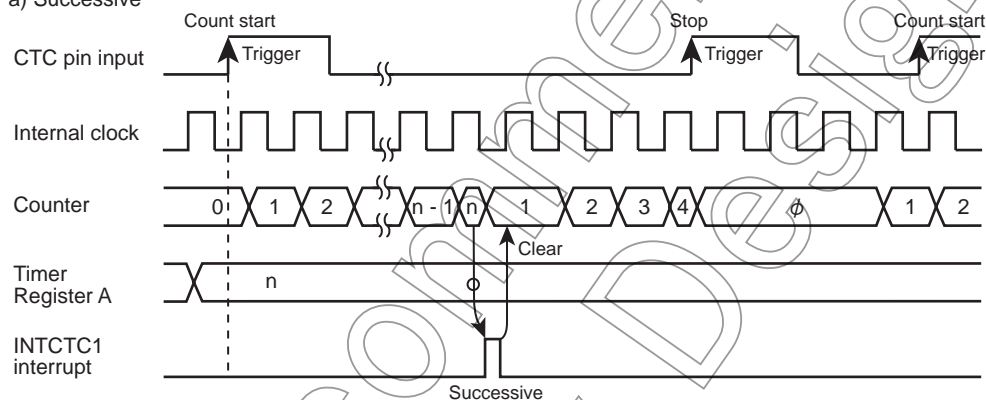

b) One Shot

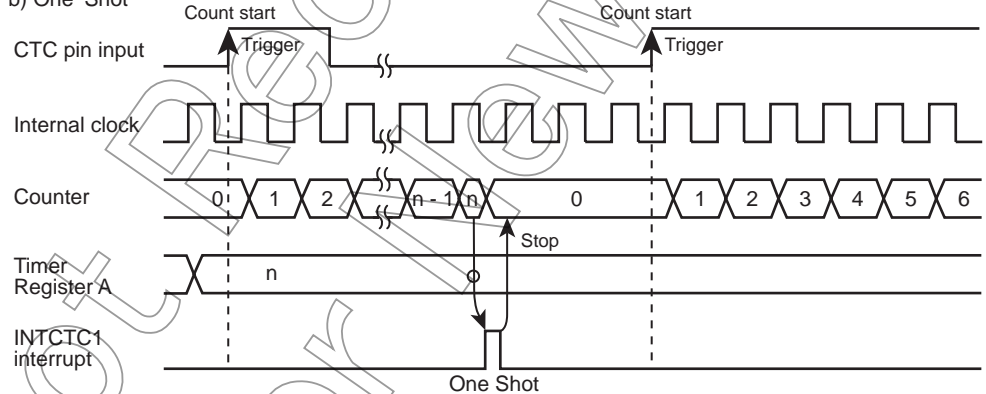

Figure 9-3 External Trigger Mode Timing Chart

(II) When rising start edge is selected, with counting enabled on both edges  
(CTC1SE = 0, CTC1E = 1)

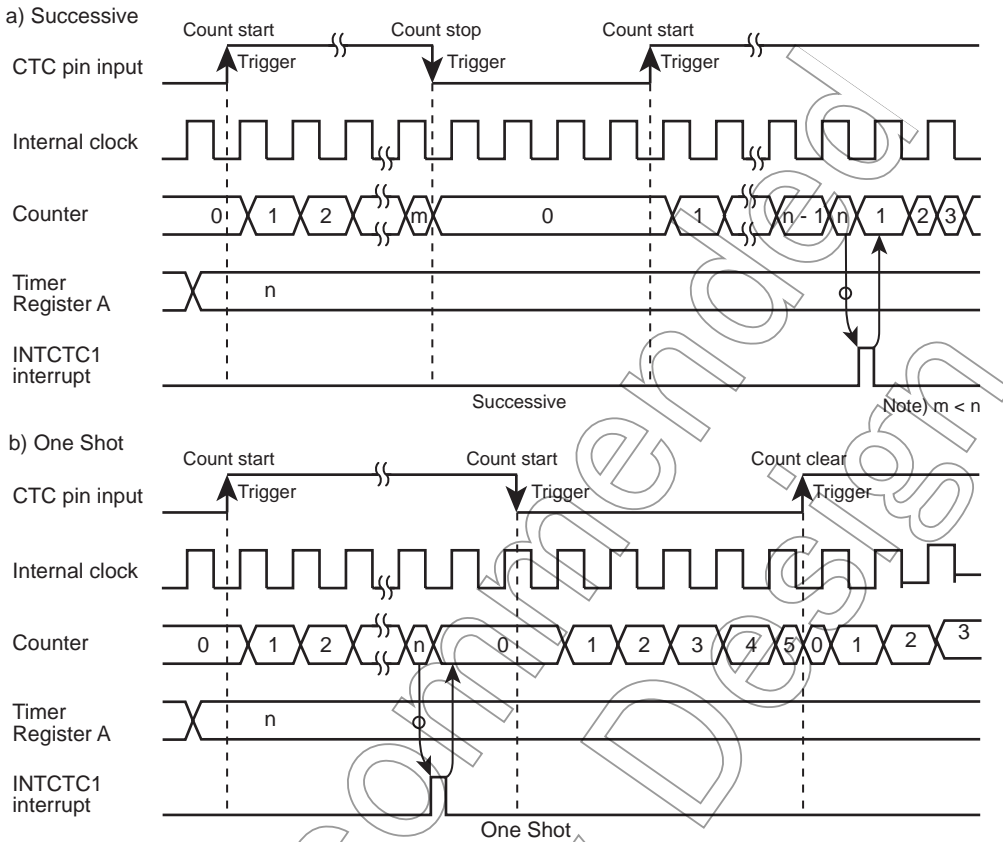

Figure 9-4 External Trigger Mode Timing Chart

### 9.3.3 Event counter mode

In this mode, the timer/counter counts up at the active edge on CTC pin input (rising or falling edge selected with the CTC1CR1<CTC1SE> which is provided for selecting external trigger edge). When the counter value and the set value of the CTC1DRA Register match, an INTCTC1 interrupt is generated and the counter is cleared. After the counter is cleared, it restarts and continues counting up at each edge on CTC pin input. The maximum applied frequency is shown in the table below. Because coincidence detection is made at an edge opposite the selected edge, the external clock signal on CTC pin must always be entered.

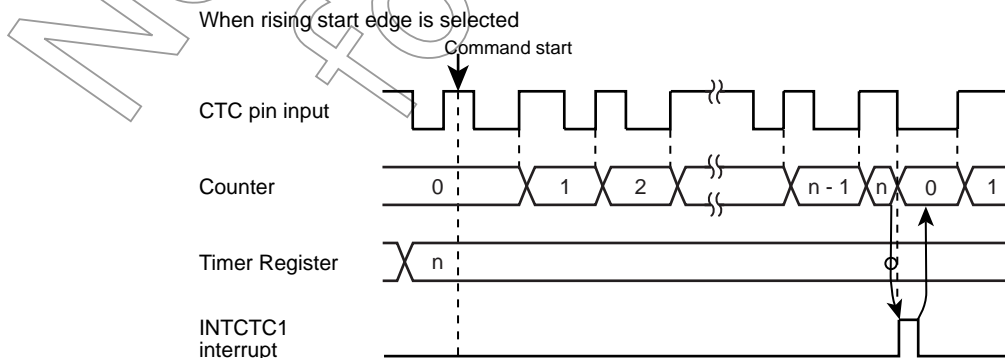

Figure 9-5 Event Counter Mode Timing Chart

Table 9-2 External Clock Source for Compare Timer/Counter 1

NORMAL and IDLE Modes	
Maximum applied frequency [Hz]	Up to $f_c/2^2$
Minimum pulse width	$2^2/f_c$ and over

### 9.3.4 Programmable Pulse Generate (PPG) output mode

The timer/counter starts counting as a command or edge on CTC pin input (rising/falling edge and one/both edges respectively selected with the CTC1CR1<CTC1SE> and CTC1CR1<CTC1E>). The source clock is an internal clock. When matched with the CTC1DR A/B/C Registers, the timer output F/F corresponding to each mode is inverted. When matched with the CTC1DR A/B/C Registers next time, the timer output F/F is inverted again. An INTCTC1 interrupt request is generated when the counter value matches the maximum register value set by CTC1CR2<CTCREG>. The timer output F/F is cleared to 0 when reset. Because CTC1CR2<CTC1FF0> can be used to set the initial value for the timer output F/F, an active-high or active-low pulse whichever is desired can be output. The CTC1DRB and CTC1DRC Registers cannot be accessed for write unless they are set for PPG output mode and the registers used are selected with CTC1CR2<CTC1REG>. The number of registers set can be altered during operation. In this case, however, be sure to set the number of registers used and write values to the data registers before the next CTC1INIT1 is output after the first CTC1INIT1 output. Even when only altering the data register values while leaving the number of registers unchanged, be sure to do this within the same period of time.

Table 9-3 Internal Clock Source for Compare Timer/Counter 1 (Example:  $f_c = 20$  MHz)

CTC1CK	NORMAL and IDLE Modes			
	DV1CK = 0		DV1CK = 1	
	Resolution [ $\mu$ s]	Maximum Setting Time [s]	Resolution [ $\mu$ s]	Maximum Setting Time [s]
000	-	-	-	-
001	-	-	-	-
010	-	-	-	-
011	-	-	-	-
100	0.2	13.11 m	-	-
101	0.1	6.55 m	0.2	13.11m
110	-	-	-	-

Note: When Port P47 is set as a CTC input port, an edge input resets the timer/counter. when PPG output mode is selected and external trigger start is not used, set CTC1CR2<EXTRGDIS> to "1" or set P47 as an output port.

(I) One register used (CTC1REG = 00)  
When set to command start.

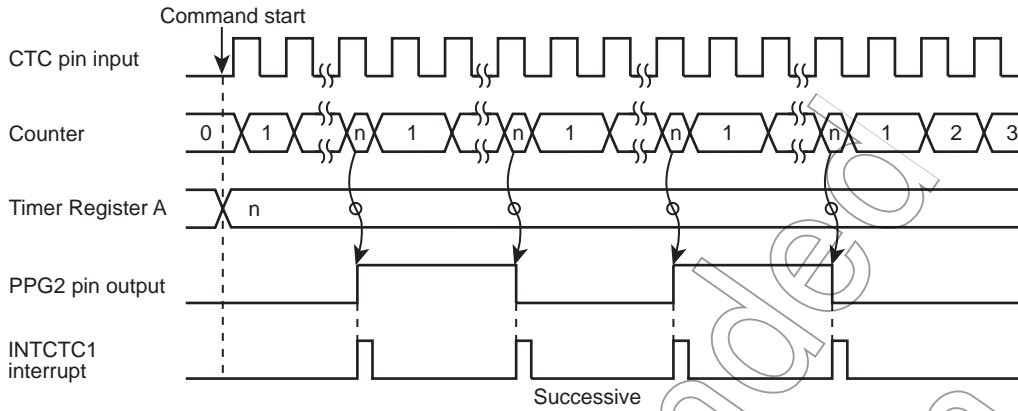

Figure 9-6 One Register Command Start Mode Timing Chart

Not Recommended for New Design

(II) Two registers used (CTC1REG = 01)

When set to the external trigger rising edge start and the one edge enable.

a) Successive

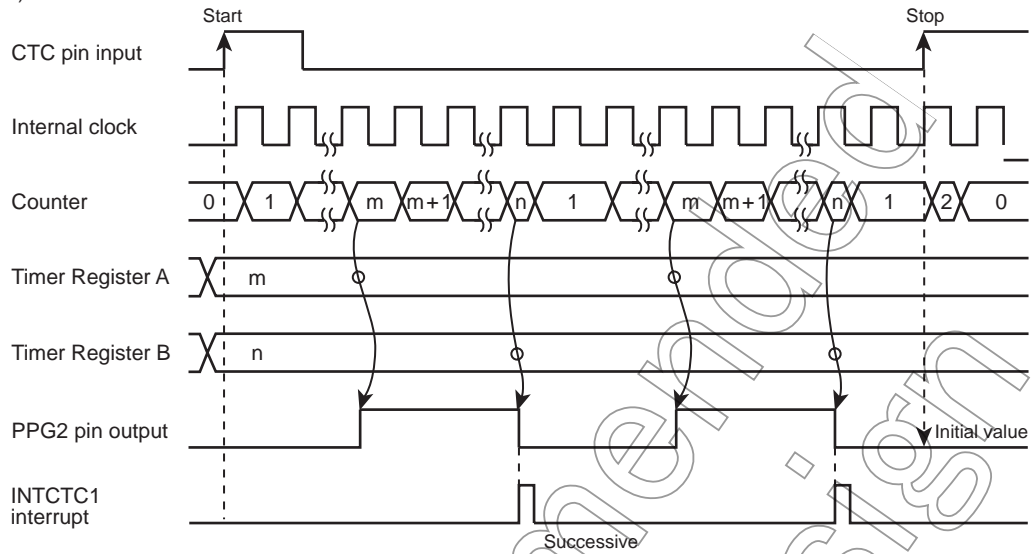

b) One shot

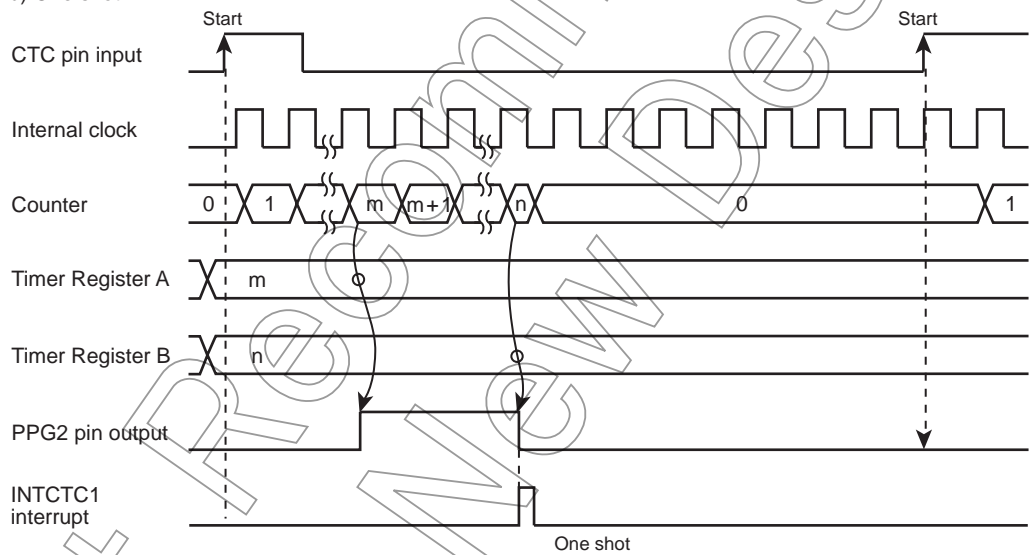
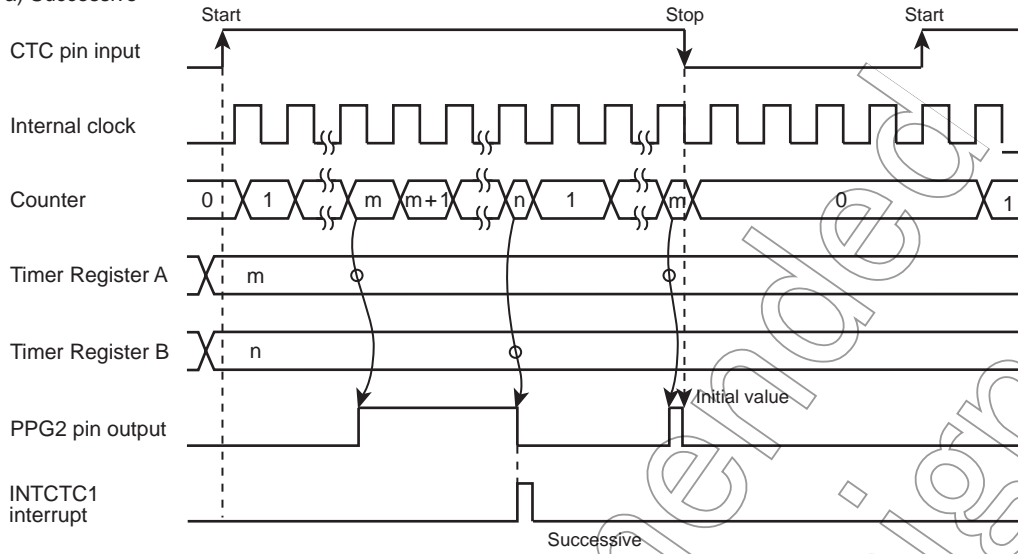

Figure 9-7 Two Register One Edge Trigger Start Mode Timing Chart

When set to the external trigger rising edge start and the both edges enable.

a) Successive



b) One shot

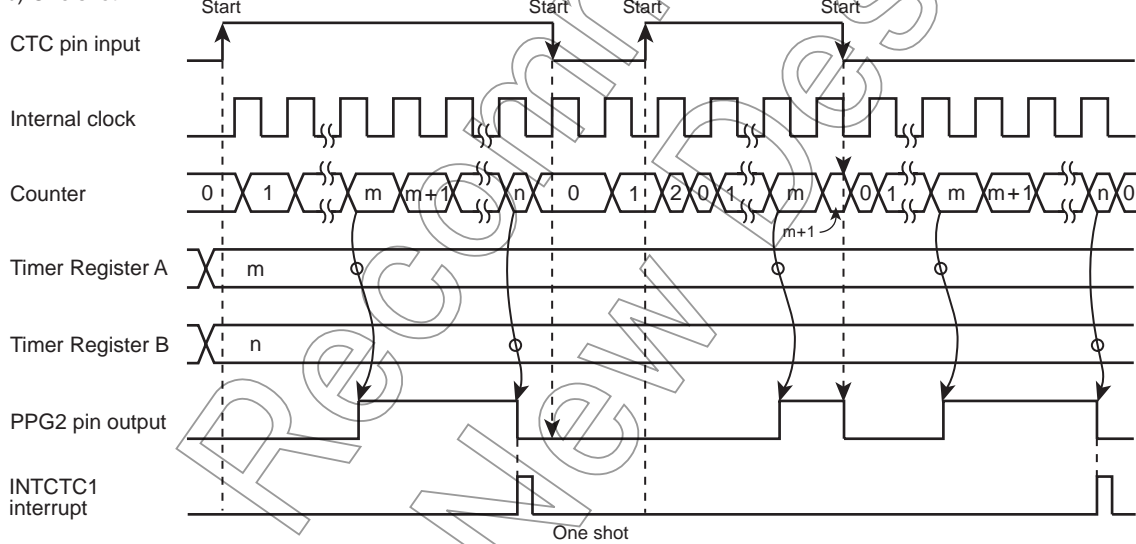
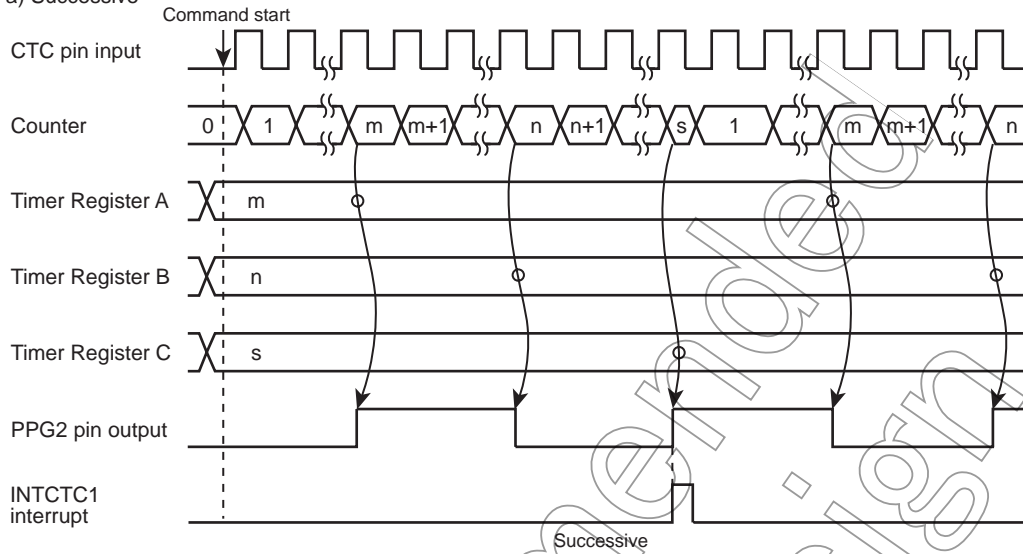

Figure 9-8 Two Register Both edges Trigger Start Mode Timing Chart

(III) Three registers used (CTC1REG = 10)  
When set to command start.

a) Successive



b) One shot

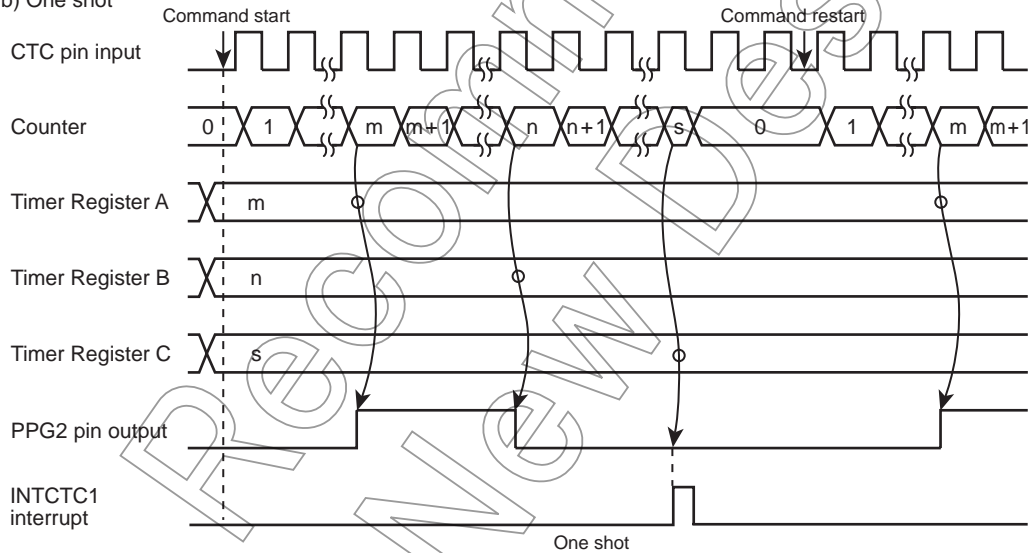

Note: In the single-shot mode, the PPG pin output is not toggled at the last register match; it stays at the value specified with CTC1CR2<CTC1FF0>.

Figure 9-9 Three Register Command Start Mode Timing Chart

Detail operation at start that varies depending on how CTC1CR2<CTC1FF0> and CTC1CR1<PPGFF0> are set during PPG output.

Table 9-4 Varying PPG Output Timing Depending on Settings

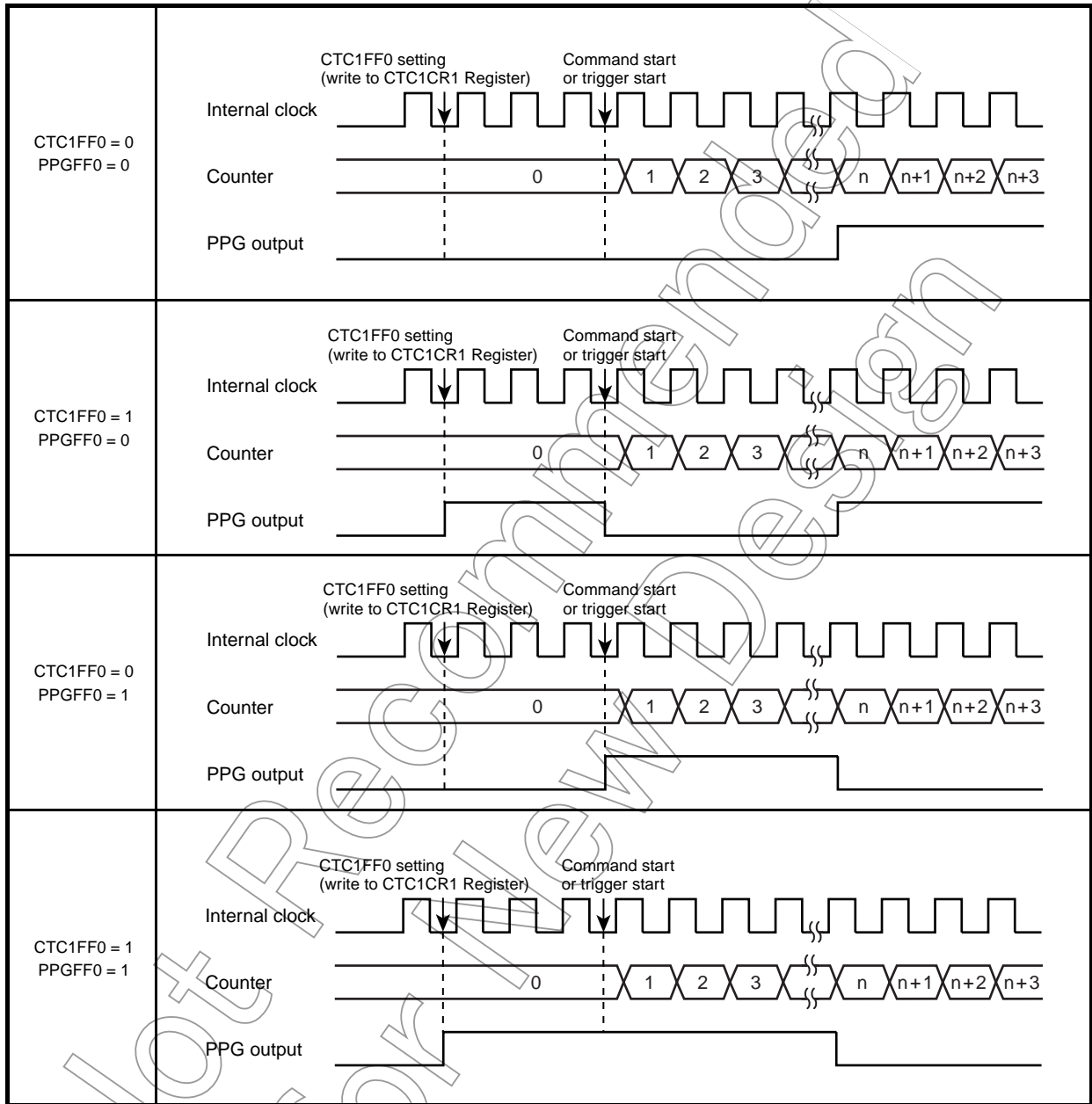

By changing the port-shared output for PPG output before the counter starts counting after setting CTC1CR2<CTC1FF0>, it is possible to determine the initial value of PPG output.



Not Recommended  
for New Design



## 10.2 TimerCounter Control

The TimerCounter 3 is controlled by the TimerCounter 3 control register (TC3CR) and two 8-bit timer registers (TC3DRA and TC3DRB).

### Timer Register and Control Register

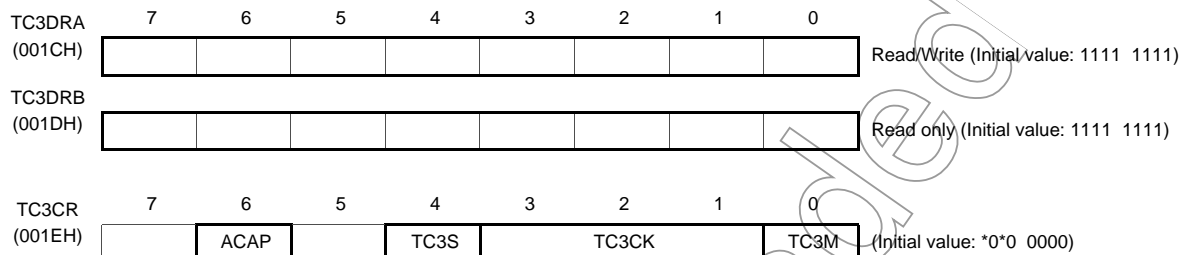

ACAP	Auto capture control	0: – 1: Auto capture	R/W	
TC3S	TC3 start control	0: Stop and counter clear 1: Start	R/W	
TC3CK	TC3 source clock select [Hz]	NORMAL, IDLE mode		
			DV1CK=0	DV1CK=1
		000	$fc/2^{13}$	$fc/2^{14}$
		001	$fc/2^{12}$	$fc/2^{13}$
		010	$fc/2^{11}$	$fc/2^{12}$
		011	$fc/2^{10}$	$fc/2^{11}$
		100	$fc/2^9$	$fc/2^{10}$
		101	$fc/2^8$	$fc/2^9$
	110	$fc/2^7$	$fc/2^8$	
	111	External clock (TC3pin input)		
TC3M	TC3 operating mode select	0: Timer/event counter mode 1: Capture mode	R/W	

Note 1: fc: High-frequency clock [Hz], \*: Don't care

Note 2: Set the operating mode and source clock when TimerCounter stops (TC3CR<TC3S> = 0).

Note 3: To set the timer registers, the following relationship must be satisfied.  
TC3DRA > 1 (Timer/event counter mode)

Note 4: Auto-capture (TC3CR<ACAP>) can be used only in the timer and event counter modes.

Note 5: When the read instruction is executed to TC3CR, the bit 5 and 7 are read as a don't care.

Note 6: Do not program TC3DRA when the timer is running (TC3CR<TC3S> = 1).

Note 7: When the STOP mode is entered, the start control (TC3CR<TC3S>) is cleared to 0 automatically, and the timer stops. After the STOP mode is exited, TC3CR<TC3S> must be set again to use the timer counter.

### 10.3 Function

TimerCounter 3 has three types of operating modes: timer, event counter and capture modes.

#### 10.3.1 Timer mode

In the timer mode, the up-counter counts up using the internal clock. When a match between the up-counter and the timer register 3A (TC3DRA) value is detected, an INTTC3 interrupt is generated and the up-counter is cleared. After being cleared, the up-counter restarts counting. Setting TC3CR<ACAP> to 1 captures the up-counter value into the timer register 3B (TC3DRB) with the auto-capture function. The count value during timer operation can be checked by executing the read instruction to TC3DRB.

Note: 00H which is stored in the up-counter immediately after detection of a match is not captured into TC3DRB. (Figure 10-2)

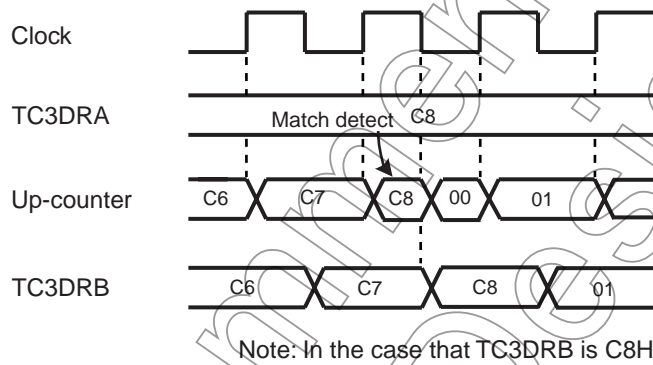

Figure 10-2 Auto-Capture Function

Table 10-1 Source Clock for TimerCounter 3 (Example: fc = 20 MHz)

TC3CK	NORMAL, IDLE mode			
	DV1CK = 0		DV1CK = 1	
	Resolution [μs]	Maximum Time Setting [ms]	Resolution [μs]	Maximum Time Setting [ms]
000	409.6	104.45	819.2	208.90
001	204.8	52.22	409.6	104.45
010	102.4	26.11	204.8	52.22
011	51.2	13.06	102.4	26.11
100	25.6	6.53	51.2	13.06
101	12.8	3.06	25.6	6.53
110	6.4	1.63	12.8	3.06

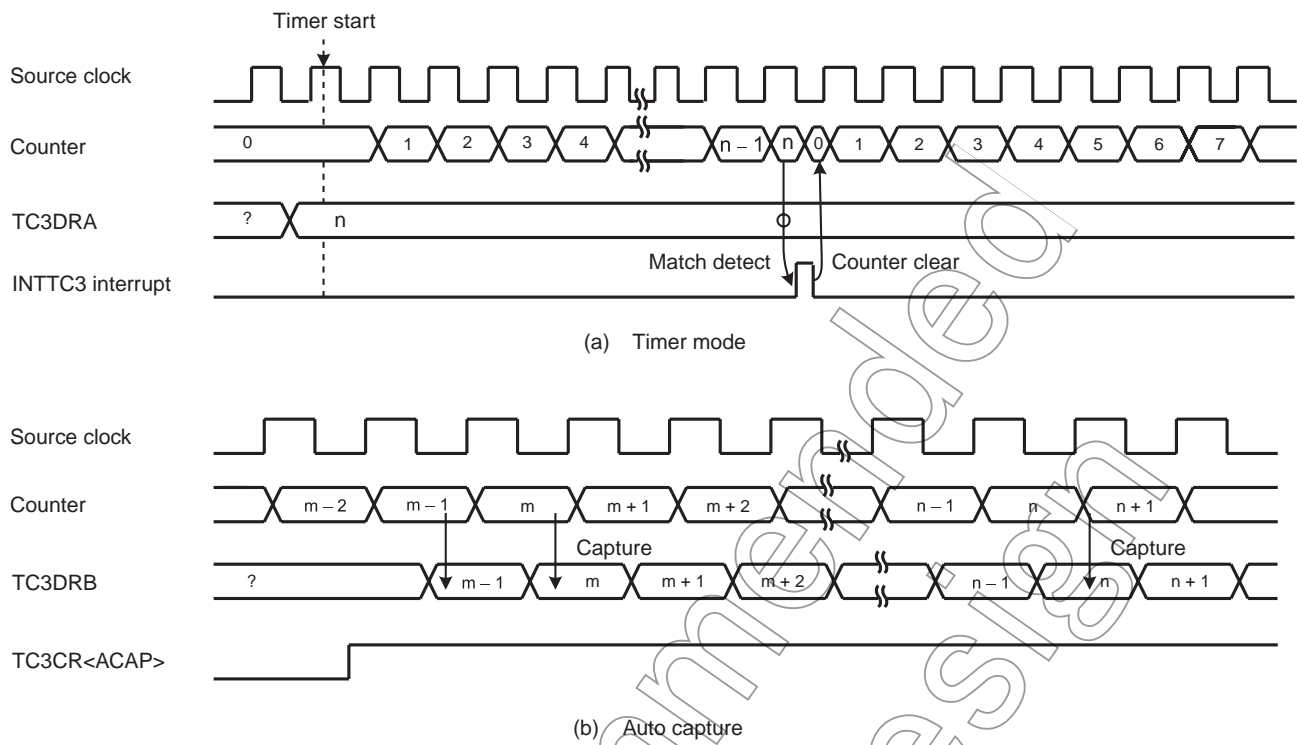

Figure 10-3 Timer Mode Timing Chart

Not Recommended for New Designs

10.3.2 Event Counter Mode

In the event counter mode, the up-counter counts up at the rising edge of the input pulse to the TC3 pin.

When a match between the up-counter and TC3DRA value is detected, an INTTC3 interrupt is generated and up-counter is cleared. After being cleared, the up-counter restarts counting at each rising edge of the input pulse to the TC3 pin. Since a match is detected at the falling edge of the input pulse to TC3 pin, an INTTC3 interrupt request is generated at the falling edge immediately after the up-counter reaches the value set in TC3DRA.

The maximum applied frequencies are shown in Table 10-2. The pulse width larger than one machine cycle is required for high-going and low-going pulses.

Setting TC3CR<ACAP> to 1 captures the up-counter value into TC3DRB with the auto-capture function. The count value during a timer operation can be checked by the read instruction to TC3DRB.

Note: 00H which is stored in the up-counter immediately after detection of a match is not captured into TC3DRB. (Figure 10-2)

Example : Inputting 50 Hz pulse to TC3, and generating interrupts every 0.5 s

- LD (TC3CR), 00001110B : Sets the clock mode
- LD (TC3DRA), 19H :  $0.5\text{ s} \div 1/50 = 25 = 19\text{H}$
- LD (TC3CR), 00011110B : Starts TC3.

Table 10-2 Maximum Frequencies Applied to TC3

	Minimum Pulse Width
	NORMAL, IDLE mode
High-going	$2^2/f_c$
Low-going	$2^2/f_c$

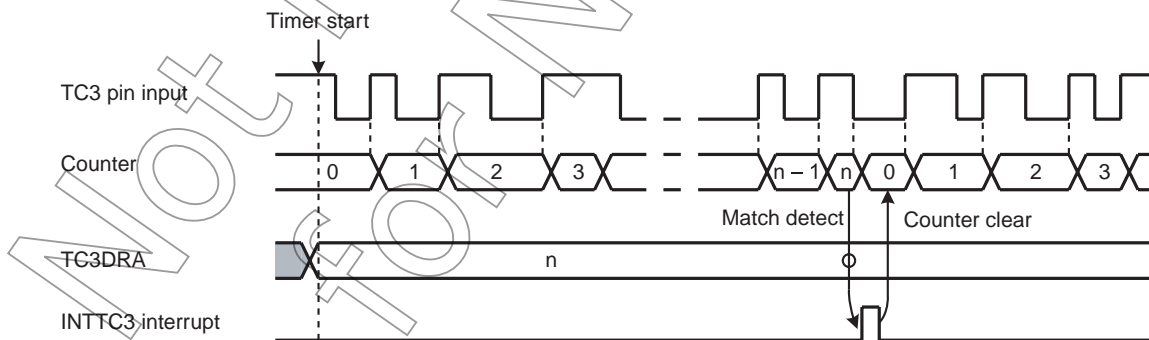

Figure 10-4 Event Counter Mode Timing Chart

### 10.3.3 Capture Mode

In the capture mode, the pulse width, frequency and duty cycle of the pulse input to the TC3 pin are measured with the internal clock. The capture mode is used to decode remote control signals, and identify AC50/60 Hz.

When the falling edge of the TC3 input is detected after the timer starts, the up-counter value is captured into TC3DRB. Hereafter, whenever the rising edge is detected, the up-counter value is captured into TC3DRA and the INTTC3 interrupt request is generated. The up-counter is cleared at this time. Generally, read TC3DRB and TC3DRA during INTTC3 interrupt processing. After the up-counter is cleared, counting is continued and the next up-counter value is captured into TC3DRB.

When the rising edge is detected immediately after the timer starts, the up-counter value is captured into TC3DRA only, but not into TC3DRB. The INTTC3 interrupt request is generated. When the read instruction is executed to TC3DRB at this time, the value at the completion of the last capture (FF immediately after a reset) is read.

The minimum input pulse width must be larger than one cycle width of the source clock programmed in TC3CR<TC3CK>.

The INTTC3 interrupt request is generated if the up-counter overflow (FFH) occurs during capture operation before the edge is detected. TC3DRA is set to FFH and the up-counter is cleared. Counting is continued by the up-counter, but capture operation and overflow detection are stopped until TC3DRA is read. Generally, read TC3DRB first because capture operation and overflow detection resume by reading TC3DRA.

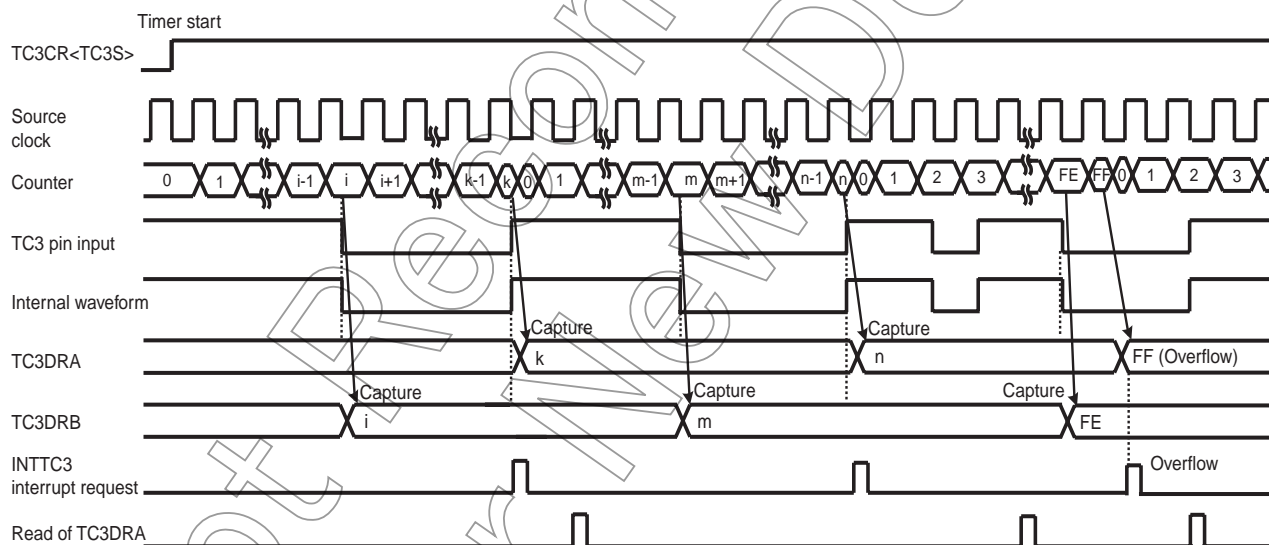
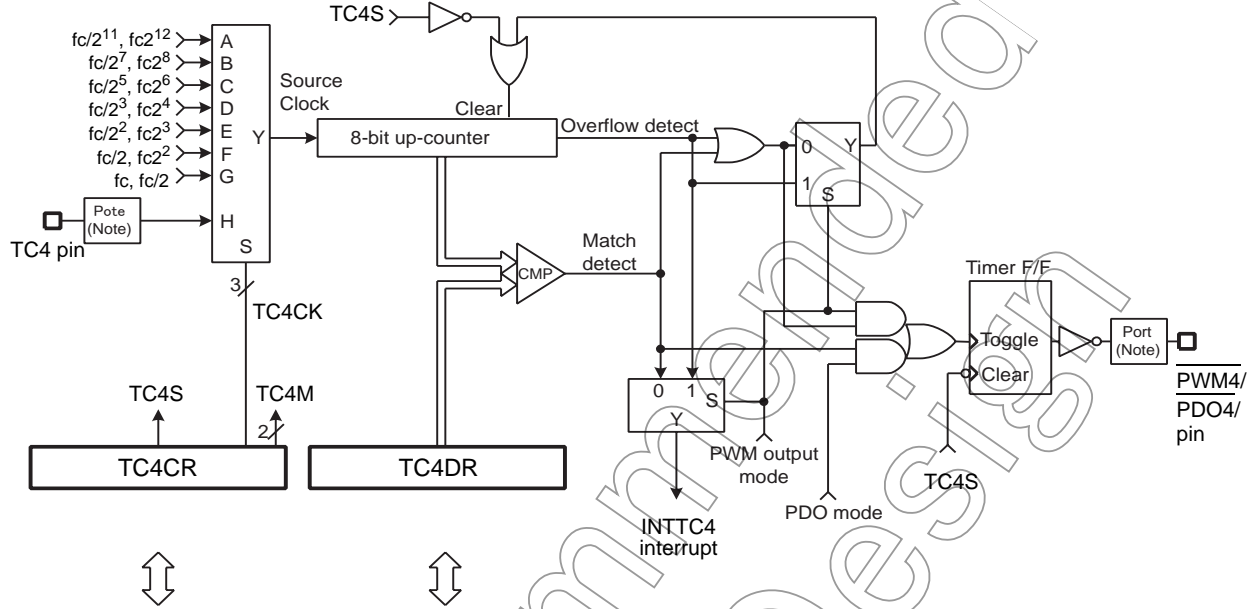

Figure 10-5 Capture Mode Timing Chart

# 11. 8-Bit TimerCounter 4 (TC4)

## 11.1 Configuration



Note: Function I/O may not operate depending on I/O port setting. For more details, see the chapter "I/O Port".

Figure 11-1 TimerCounter 4 (TC4)



## 11.2 TimerCounter Control

The TimerCounter 4 is controlled by the TimerCounter 4 control register (TC4CR) and timer registers 4 (TC4DR).

### Timer Register and Control Register

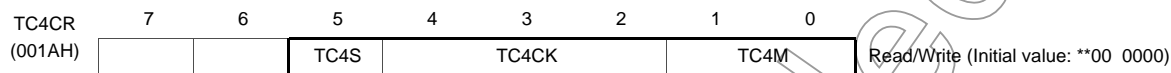
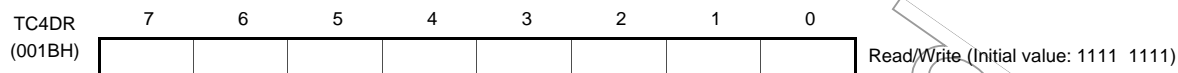

TC4S	TC4 start control	0: Stop and counter clear 1: Start	R/W			
TC4CK	TC4 source clock select [Hz]	NORMAL, IDLE mode				
		DV1CK = 0		DV1CK = 1		
		000	$fc/2^{11}$	$fc/2^{12}$	R/W	
		001	$fc/2^7$	$fc/2^8$		
		010	$fc/2^5$	$fc/2^6$		
		011	$fc/2^3$	$fc/2^4$		
		100	$fc/2^2$	$fc/2^3$		
		101	$fc/2$	$fc/2^2$		
		110	$(fc)^{Note8}$	$(fc/2)^{Note8}$		
		111	External clock (TC4 pin input)			
		TC4M	TC4 operating mode select	00: Timer/event counter mode		R/W
				01: Reserved		
10: Programmable divider output (PDO) mode						
11: Pulse width modulation (PWM) output mode						

Note 1: fc: High-frequency clock [Hz], \*: Don't care

Note 2: To set the timer registers, the following relationship must be satisfied.  
 $1 \leq TC4DR \leq 255$

Note 3: To start timer operation (TC4CR<TC4S> = 0 → 1) or disable timer operation (TC4CR<TC4S> = 1 → 0), do not change the TC4CR<TC4M, TC4CK> setting. During timer operation (TC4CR<TC4S> = 1 → 1), do not change it, either. If the setting is programmed during timer operation, counting is not performed correctly.

Note 4: The event counter and PWM output modes are used only in the NORMAL and IDLE modes.

Note 5: When the STOP mode is entered, the start control (TC4S) is cleared to "0" automatically.

Note 6: The bit 6 and 7 of TC4CR are read as a don't care when these bits are read.

Note 7: In the timer, event counter and PDO modes, do not change the TC4DR setting when the timer is running.

Note 8: When the high-frequency clock fc exceeds 10 MHz, do not select the source clock of TC4CR< TC4CK> = 110.

Note 9: For available source clocks depending on the operation mode, refer to the following table.

		Timer Mode	Event Counter Mode	PDO Mode	PWM Mode
TC4CK	000	O	-	O	-
	001	O	-	O	-
	010	O	-	O	-
	011	O	-	-	O
	100	-	-	-	O
	101	-	-	-	O
	110	-	-	-	O
	111	-	O	-	x

Note: O : Available source clock

## 11.3 Function

TimerCounter 4 has four types of operating modes: timer, event counter, programmable divider output (PDO), and pulse width modulation (PWM) output modes.

### 11.3.1 Timer Mode

In the timer mode, the up-counter counts up using the internal clock. When a match between the up-counter and the TC4DR value is detected, an INTTC4 interrupt is generated and the up-counter is cleared. After being cleared, the up-counter restarts counting.

Table 11-1 Internal Source Clock for TimerCounter 4 (Example: fc = 20 MHz)

TC4CK	NORMAL, IDLE Mode			
	DV1CK = 0		DV1CK = 1	
	Resolution [μs]	Maximum Time Setting [ms]	Resolution [μs]	Maximum Time Setting [ms]
000	102.4	26.11	204.8	52.22
001	6.4	1.63	12.8	3.28
010	1.6	0.41	3.2	0.82
011	0.4	0.10	0.8	0.20

### 11.3.2 Event Counter Mode

In the event counter mode, the up-counter counts up at the rising edge of the input pulse to the TC4 pin.

When a match between the up-counter and the TC4DR value is detected, an INTTC4 interrupt is generated and the up-counter is cleared. After being cleared, the up-counter restarts counting at rising edge of the TC4 pin. Since a match is detected at the falling edge of the input pulse to the TC4 pin, the INTTC4 interrupt request is generated at the falling edge immediately after the up-counter reaches the value set in TC4DR.

The minimum pulse width applied to the TC4 pin are shown in Table 11-2. The pulse width larger than two machine cycles is required for high- and low-going pulses.

Note: The event counter mode can be used in the NORMAL and IDLE modes only.

Table 11-2 External Source Clock for TimerCounter 4

	Minimum Pulse Width
	NORMAL, IDLE mode
High-going	$2^3/fc$
Low-going	$2^3/fc$

### 11.3.3 Programmable Divider Output (PDO) Mode

The programmable divider output (PDO) mode is used to generate a pulse with a 50% duty cycle by counting with the internal clock.

When a match between the up-counter and the TC4DR value is detected, the logic level output from the PDO4 pin is switched to the opposite state and INTTC4 interrupt request is generated. The up-counter is cleared at this time and then counting is continued. When a match between the up-counter and the TC4DR value is detected, the logic level output from the PDO4 pin is switched to the opposite state again and INTTC4 interrupt request is generated. The up-counter is cleared at this time, and then counting and PDO are continued.

When the timer is stopped, the PDO4 pin is high. Therefore, if the timer is stopped when the PDO4 pin is low, the duty pulse may be shorter than the programmed value.

Example :Generating 1024 Hz pulse (fc = 20.0 Mhz and CGCR<DV1CK> = 0)

LD	(TC4CR), 00000110B	: Sets the PDO mode. (TC4M = 10, TC4CK = 001)
SET	(P2DR), 2	: Sets the P22 output latch to 1.
LD	(TC4DR), 4CH	: $1/1024 \div 2^7 / fc \div 2$ (half cycle period) = 4CH
LD	(TC4CR), 00100110B	: Start TC4

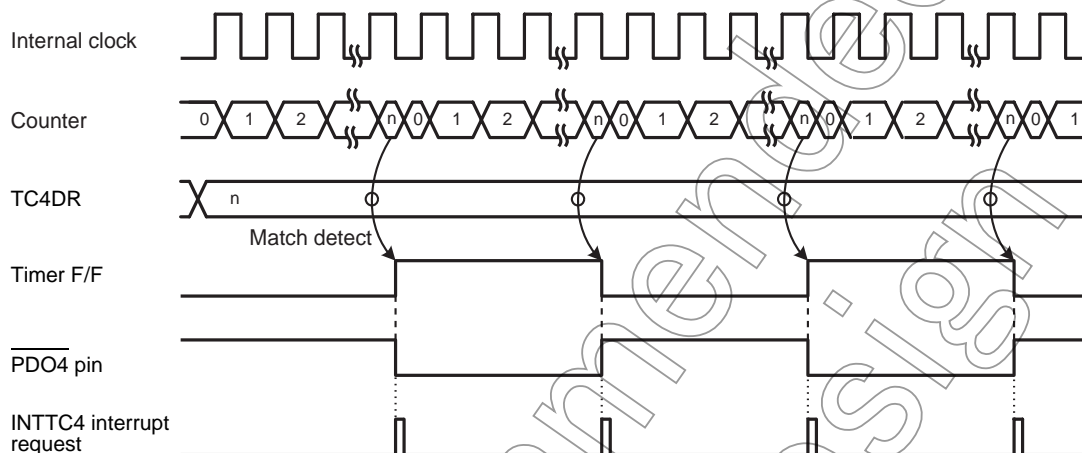

Figure 11-2. PDO Mode Timing Chart

### 11.3.4 Pulse Width Modulation (PWM) Output Mode

The pulse width modulation (PWM) output mode is used to generate the PWM pulse with up to 8 bits of resolution by an internal clock.

When a match between the up-counter and the TC4DR value is detected, the logic level output from the PWM4 pin becomes low. The up-counter continues counting. When the up-counter overflow occurs, the PWM4 pin becomes high. The INTTC4 interrupt request is generated at this time.

When the timer is stopped, the PWM4 pin is high. Therefore, if the timer is stopped when the PWM4 pin is low, one PWM cycle may be shorter than the programmed value.

TC4DR is serially connected to the shift register. If TC4DR is programmed during PWM output, the data set to TC4DR is not shifted until one PWM cycle is completed. Therefore, a pulse can be modulated periodically. For the first time, the data written to TC4DR is shifted when the timer is started by setting TC4CR<TC4S> to 1.

Note 1: The PWM output mode can be used only in the NORMAL and IDEL modes.

Note 2: In the PWM output mode, program TC4DR immediately after the INTTC4 interrupt request is generated (typically in the INTTC4 interrupt service routine.) When the programming of TC4DR and the INTTC4 interrupt occur at the same time, an unstable value is shifted, that may result in generation of pulse different from the programmed value until the next INTTC4 interrupt request is issued.

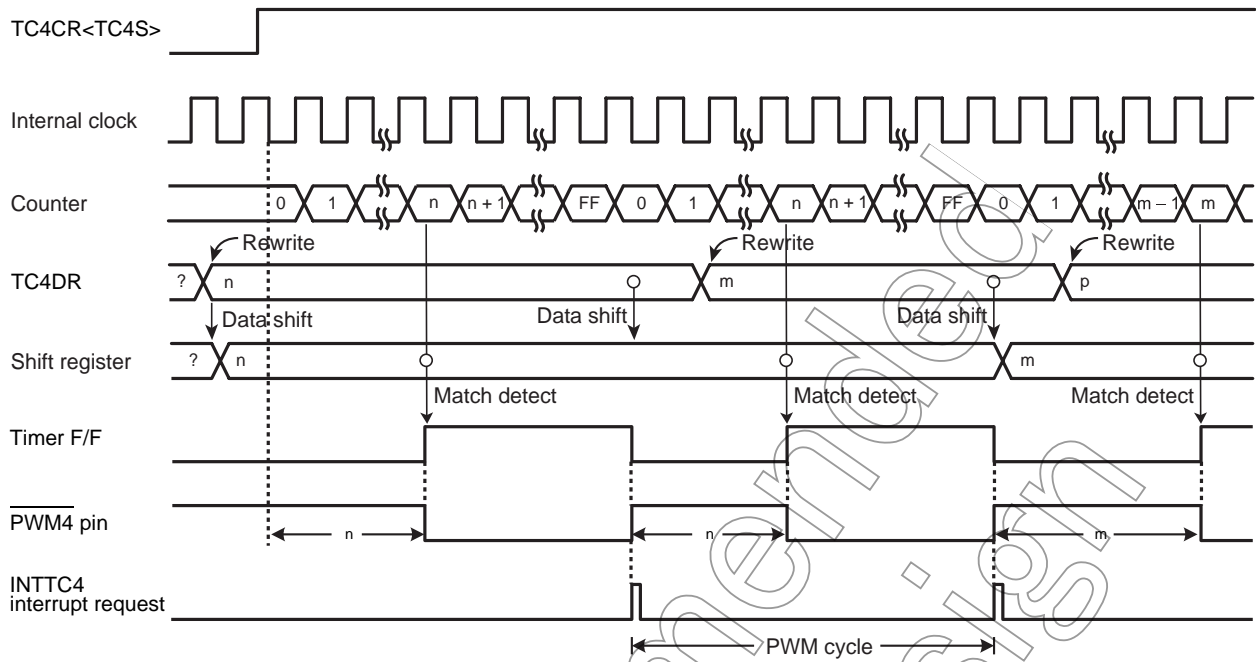

Figure 11-3 PWM output Mode Timing Chart (TC4)

Table 11-3 PWM Mode (Example:  $f_c = 20\text{ MHz}$ )

TC4CK	NORMAL, IDLE Mode			
	DV1CK = 0		DV1CK = 1	
	Resolution [ns]	Cycle [ $\mu\text{s}$ ]	Resolution [ns]	Cycle [ $\mu\text{s}$ ]
000	-	-	-	-
001	-	-	-	-
010	-	-	-	-
011	400	102.4	800	204.8
100	200	51.2	400	102.4
101	100	25.6	200	51.2
110	-	-	-	-

Not Recommended  
for New Design

# 12. 8-Bit TimerCounter 5,6(TC5, 6)

## 12.1 Configuration

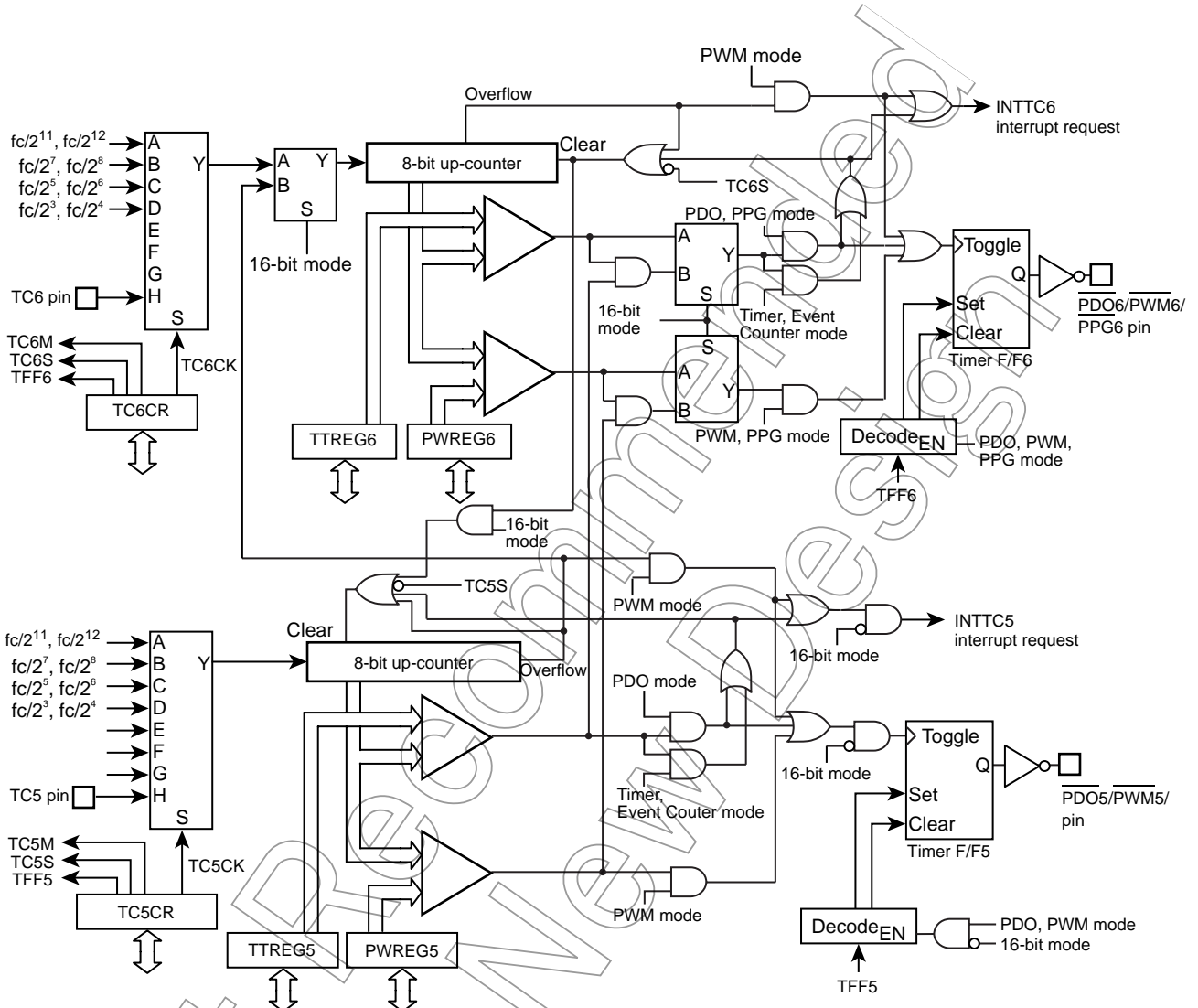
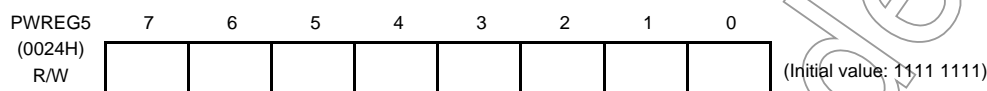
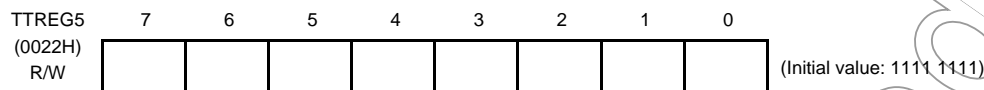

Figure 12-1 8-Bit TimerCounter 5, 6

## 12.2 TimerCounter Control

The TimerCounter 5 is controlled by the TimerCounter 5 control register (TC5CR) and two 8-bit timer registers (TTREG5, PWREG5).

### TimerCounter 5 Timer Register



Note 1: Do not change the timer register (TTREG5) setting while the timer is running.

Note 2: Do not change the timer register (PWREG5) setting in the operating mode except the 8-bit and 16-bit PWM modes while the timer is running.

### TimerCounter 5 Control Register

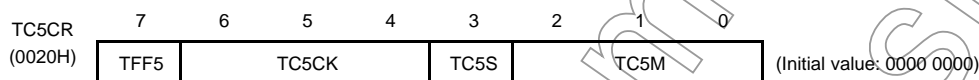

TFF5	Time F/F5 control	0: Clear 1: Set	R/W	
TC5CK	Operating clock selection [Hz]	NORMAL, IDLE mode		
		DV1CK = 0		
		DV1CK = 1		
		000	$fc/2^{11}$	$fc/2^{12}$
		001	$fc/2^7$	$fc/2^8$
		010	$fc/2^5$	$fc/2^6$
		011	$fc/2^3$	$fc/2^4$
		100	-	-
101	-	-		
110	-	-		
111	TC5I pin input			
TC5S	TC5 start control	0: Operation stop and counter clear 1: Operation start	R/W	
TC5M	TC5M operating mode select	000: 8-bit timer/event counter mode 001: 8-bit programmable divider output (PDO) mode 010: 8-bit pulse width modulation (PWM) output mode 011: 16-bit mode (Each mode is selectable with TC6M.) 1**: Reserved	R/W	

Note 1: fc: High-frequency clock [Hz]

Note 2: Do not change the TC5M, TC5CK and TFF5 settings while the timer is running.

Note 3: To stop the timer operation (TC5S= 1 → 0), do not change the TC5M, TC5CK and TFF5 settings. To start the timer operation (TC5S= 0 → 1), TC5M, TC5CK and TFF5 can be programmed.

Note 4: To use the TimerCounter in the 16-bit mode, set the operating mode by programming TC6CR<TC6M>, where TC5M must be fixed to 011.

Note 5: To use the TimerCounter in the 16-bit mode, select the source clock by programming TC5CK. Set the timer start control and timer F/F control by programming TC6CR<TC6S> and TC6CR<TFF6>, respectively.

Note 6: The operating clock settings are limited depending on the timer operating mode. For the detailed descriptions, see Table 12-1.

Note 7: The timer register settings are limited depending on the timer operating mode. For the detailed descriptions, see Table 12-2.

Not Recommended  
for New Design



The TimerCounter 6 is controlled by the TimerCounter 6 control register (TC6CR) and two 8-bit timer registers (TTREG6 and PWREG6).

### TimerCounter 6 Timer Register

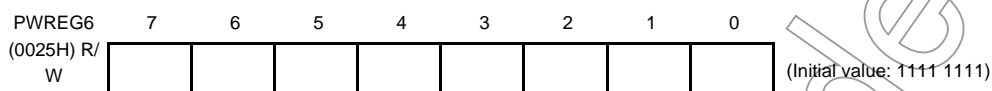
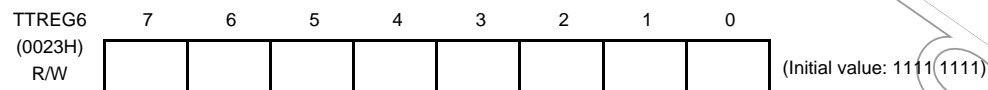

Note 1: Do not change the timer register (TTREG6) setting while the timer is running.

Note 2: Do not change the timer register (PWREG6) setting in the operating mode except the 8-bit and 16-bit PWM modes while the timer is running.

### TimerCounter 6 Control Register

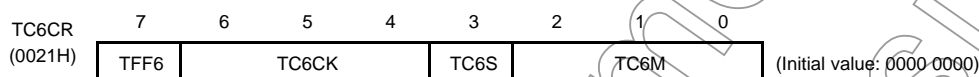

TFF6	Timer F/F6 control	0: Clear 1: Set	R/W	
TC6CK	Operating clock selection [Hz]	NORMAL, IDLE mode		
		DV1CK = 0		
		DV1CK = 1		
		000	$fc/2^{11}$	$fc/2^{12}$
		001	$fc/2^7$	$fc/2^8$
		010	$fc/2^5$	$fc/2^5$
		011	$fc/2^3$	$fc/2^3$
		100	-	-
101	-	-		
110	-	-		
111	TC6I pin input			
TC6S	TC6 start control	0: Operation stop and counter clear 1: Operation start	R/W	
TC6M	TC6M operating mode select	000: 8-bit timer/event counter mode 001: 8-bit programmable divider output (PDO) mode 010: 8-bit pulse width modulation (PWM) output mode 011: Reserved 100: 16-bit timer/event counter mode 101: Warm-up counter mode 110: 16-bit pulse width modulation (PWM) output mode 111: 16-bit PPG mode	R/W	

Note 1: fc: High-frequency clock [Hz]

Note 2: Do not change the TC6M, TC6CK and TFF6 settings while the timer is running.

Note 3: To stop the timer operation (TC6S = 1 → 0), do not change the TC6M, TC6CK and TFF6 settings.  
To start the timer operation (TC6S = 0 → 1), TC6M, TC6CK and TFF6 can be programmed.

Note 4: When TC6M = 1\*\* (upper byte in the 16-bit mode), the source clock becomes the TC6 overflow signal regardless of the TC5CK setting.

Note 5: To use the TimerCounter in the 16-bit mode, select the operating mode by programming TC6M, where TC5CR < TC5M > must be set to 011.

Note 6: To the TimerCounter in the 16-bit mode, select the source clock by programming TC5CR < TC5CK >. Set the timer start control and timer F/F control by programming TC6S and TFF6, respectively.

Note 7: The operating clock settings are limited depending on the timer operating mode. For the detailed descriptions, see Table 12-1.

Note 8: The timer register settings are limited depending on the timer operating mode. For the detailed descriptions, see Table 12-2.

Table 12-1 Operating Mode and Selectable Source Clock (NORMAL and IDLE Modes)

Operating mode	fc/2 <sup>11</sup>	fc/2 <sup>7</sup>	fc/2 <sup>5</sup>	fc/2 <sup>3</sup>	TC5 pin input	TC6 pin input
8-bit timer	0	0	0	0	-	-
8-bit event counter	-	-	-	-	0	0
8-bit PDO	0	0	0	0	-	-
8-bit PWM	0	0	0	0	-	-
16-bit timer	0	0	0	0	-	-
16-bit event counter	-	-	-	-	0	0
16-bit PWM	0	0	0	0	0	0
16-bit PPG	0	0	0	0	0	0

Note 1: For 16-bit operations (16-bit timer/event counter, warm-up counter, 16-bit PWM and 16-bit PPG), set its source clock on lower bit (TC5CK).

Note 2: 0 : Available source clock

Table 12-2 Constraints on Register Values Being Compared

Operating mode	Register Value
8-bit timer/event counter	$1 \leq (TTREGn) \leq 255$
8-bit PDO	$1 \leq (TTREGn) \leq 255$
8-bit PWM	$2 \leq (PWREGn) \leq 254$
16-bit timer/event counter	$1 \leq (TTREG6, 5) \leq 65535$
16-bit PWM	$2 \leq (PWREG6, 5) \leq 65534$
16-bit PPG	$1 \leq (PWREG6, 5) < (TTREG6, 5) \leq 65535$ and $(PWREG6, 5) + 1 < (TTREG6, 5)$

Note: n = 5 to 6

## 12.3 Function

The TimerCounter 5 and 6 have the 8-bit timer, 8-bit event counter, 8-bit programmable divider output (PDO), 8-bit pulse width modulation (PWM) output modes. The TimerCounter 5 and 6 (TC5, 6) are cascadable to form a 16-bit timer. The 16-bit timer has the operating modes such as the 16-bit timer, 16-bit event counter, 16-bit pulse width modulation (PWM) output and 16-bit programmable pulse generation (PPG) modes.

### 12.3.1 8-Bit Timer Mode (TC5 and 6)

In the timer mode, the up-counter counts up using the internal clock. When a match between the up-counter and the timer register  $j$  (TTREG $j$ ) value is detected, an INTTC $j$  interrupt is generated and the up-counter is cleared. After being cleared, the up-counter restarts counting.

Note 1: In the timer mode, fix TCjCR<TFFj> to 0. If not fixed, the PDO $j$ , PWM $j$  and PPG $j$  pins may output pulses.

Note 2: In the timer mode, do not change the TTREG $j$  setting while the timer is running. Since TTREG $j$  is not in the shift register configuration in the timer mode, the new value programmed in TTREG $j$  is in effect immediately after the programming. Therefore, if TTREG $i$  is changed while the timer is running, an expected operation may not be obtained.

Note 3:  $j = 5, 6$

Table 12-3 Source Clock for TimerCounter 5, 6 (Internal Clock)

Source Clock		Resolution	Repeated Cycle
NORMAL, IDLE mode		DV1CK = 0	DV1CK = 0
DV1CK = 0	DV1CK = 1	$f_c = 20 \text{ MHz}$	$f_c = 20 \text{ MHz}$
$f_c/2^{11}$ [Hz]	$f_c/2^{12}$ [Hz]	128 $\mu\text{s}$	32.6 ms
$f_c/2^7$	$f_c/2^8$	8 $\mu\text{s}$	2.0 ms
$f_c/2^5$	$f_c/2^6$	2 $\mu\text{s}$	510 $\mu\text{s}$
$f_c/2^3$	$f_c/2^4$	500 ns	127.5 $\mu\text{s}$

Example :Setting the timer mode with source clock  $f_c/2^7$  Hz and generating an interrupt 64  $\mu\text{s}$  later (TimerCounter6,  $f_c = 20.0 \text{ MHz}$ )

```
LD   (TTREG6), 0AH           : Sets the timer register ( $80 \mu\text{s} \div 2^7 / f_c = 0AH$ ).
DI
SET  (EIRC), EF37           : Enables INTTC6 interrupt.
EI
LD   (TC6CR), 00010000B     : Sets the operating clock to  $f_c/2^7$ , and 8-bit timer mode.
LD   (TC6CR), 00011000B     : Starts TC6.
```

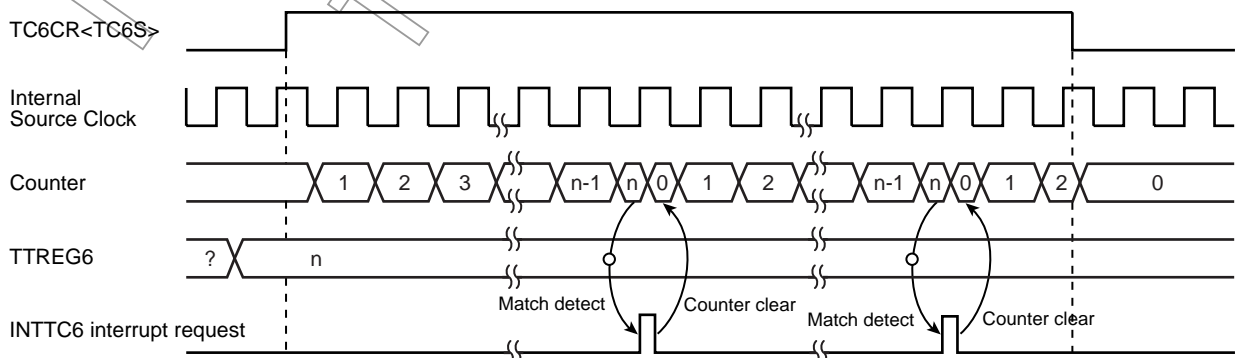

Figure 12-2 8-Bit Timer Mode Timing Chart (TC6)

### 12.3.2 8-Bit Event Counter Mode (TC5, 6)

In the 8-bit event counter mode, the up-counter counts up at the falling edge of the input pulse to the TCj pin. When a match between the up-counter and the TTREGj value is detected, an INTTCj interrupt is generated and the up-counter is cleared. After being cleared, the up-counter restarts counting at the falling edge of the input pulse to the TCj pin. Two machine cycles are required for the low- or high-level pulse input to the TCj pin. Therefore, a maximum frequency to be supplied is  $f_c/2^4$  Hz in the NORMAL or IDLE mode.

Note 1: In the event counter mode, fix TCjCR<TFFj> to 0. If not fixed, the  $\overline{PDOj}$ , PWMj and PPGj pins may output pulses.

Note 2: In the event counter mode, do not change the TTREGj setting while the timer is running. Since TTREGj is not in the shift register configuration in the event counter mode, the new value programmed in TTREGj is in effect immediately after the programming. Therefore, if TTREGj is changed while the timer is running, an expected operation may not be obtained.

Note 3: j = 5, 6

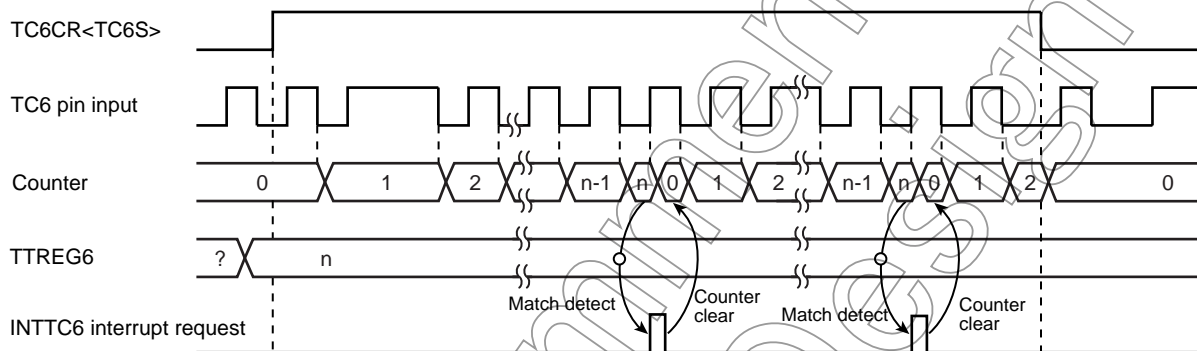

Figure 12-3 8-Bit Event Counter Mode Timing Chart (TC6)

### 12.3.3 8-Bit Programmable Divider Output (PDO) Mode (TC5, 6)

This mode is used to generate a pulse with a 50% duty cycle from the  $\overline{PDOj}$  pin.

In the PDO mode, the up-counter counts up using the internal clock. When a match between the up-counter and the TTREGj value is detected, the logic level output from the  $\overline{PDOj}$  pin is switched to the opposite state and the up-counter is cleared. The INTTCj interrupt request is generated at the time. The logic state opposite to the timer F/Fj logic level is output from the  $\overline{PDOj}$  pin. An arbitrary value can be set to the timer F/Fj by TCjCR<TFFj>. Upon reset, the timer F/Fj value is initialized to 0.

To use the programmable divider output, set the output latch of the I/O port to 1.

Example :Generating 1024 Hz pulse using TC6 ( $f_c = 20.0$  MHz)

Setting port		
LD	(TTREG6), 3DH	: $1/1024 \div 2^7 / f_c \div 2 = 3DH$
LD	(TC6CR), 00010001B	: Sets the operating clock to $f_c/2^7$ , and 8-bit PDO mode.
LD	(TC6CR), 00011001B	: Starts TC6.

Note 1: In the programmable divider output mode, do not change the TTREGj setting while the timer is running. Since TTREGj is not in the shift register configuration in the programmable divider output mode, the new value programmed in TTREGj is in effect immediately after programming. Therefore, if TTREGj is changed while the timer is running, an expected operation may not be obtained.

Note 2: When the timer is stopped during PDO output, the  $\overline{PDOj}$  pin holds the output status when the timer is stopped. To change the output status, program TCjCR<TFFj> after the timer is stopped. Do not change the TCjCR<TFFj> setting upon stopping of the timer.

Example: Fixing the  $\overline{PDOj}$  pin to the high level when the TimerCounter is stopped

CLR (TCjCR).3: Stops the timer.

CLR (TCjCR).7: Sets the  $\overline{PDOj}$  pin to the high level.

Note 3: j = 5, 6

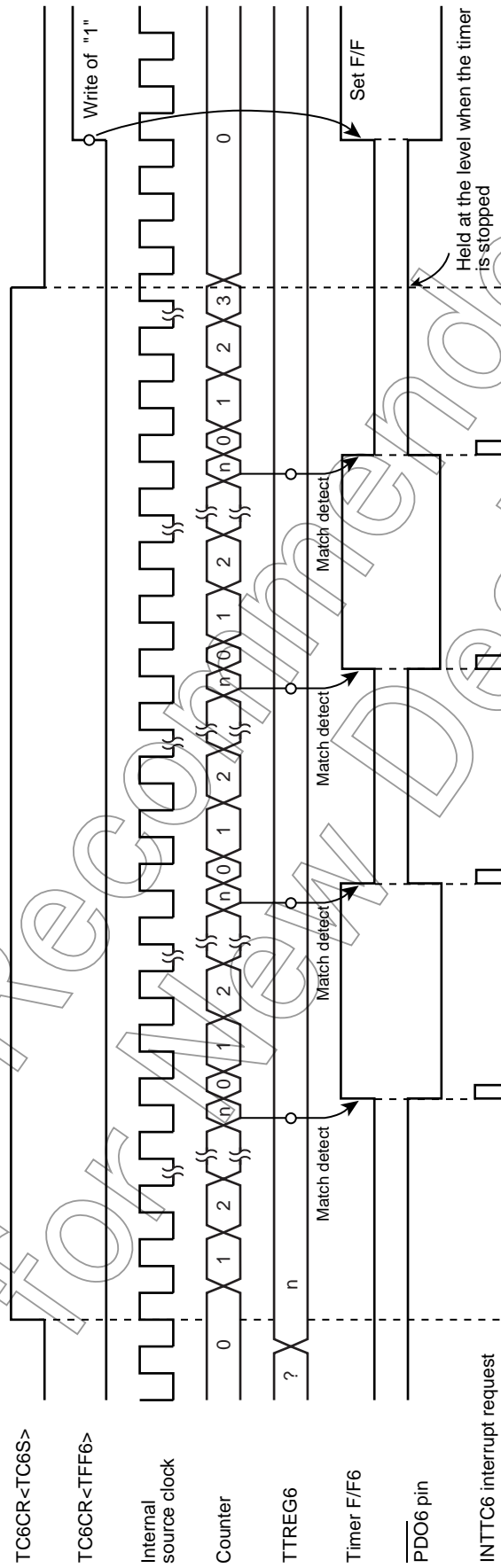

Figure 12-4 8-Bit PDO Mode Timing Chart (TC6)

### 12.3.4 8-Bit Pulse Width Modulation (PWM) Output Mode (TC5, 6)

This mode is used to generate a pulse-width modulated (PWM) signals with up to 8 bits of resolution. The up-counter counts up using the internal clock.

When a match between the up-counter and the PWREGj value is detected, the logic level output from the timer F/Fj is switched to the opposite state. The counter continues counting. The logic level output from the timer F/Fj is switched to the opposite state again by the up-counter overflow, and the counter is cleared. The INTTCj interrupt request is generated at this time.

Since the initial value can be set to the timer F/Fj by TCjCR<TFFj>, positive and negative pulses can be generated. Upon reset, the timer F/Fj is cleared to 0.

(The logic level output from the  $\overline{\text{PWMj}}$  pin is the opposite to the timer F/Fj logic level.)

Since PWREGj in the PWM mode is serially connected to the shift register, the value set to PWREGj can be changed while the timer is running. The value set to PWREGj during a run of the timer is shifted by the INTTCj interrupt request and loaded into PWREGj. While the timer is stopped, the value is shifted immediately after the programming of PWREGj. If executing the read instruction to PWREGj during PWM output, the value in the shift register is read, but not the value set in PWREGj. Therefore, after writing to PWREGj, the reading data of PWREGj is previous value until INTTCj is generated.

For the pin used for PWM output, the output latch of the I/O port must be set to 1.

Note 1: In the PWM mode, program the timer register PWREGj immediately after the INTTCj interrupt request is generated (normally in the INTTCj interrupt service routine.) If the programming of PWREGj and the interrupt request occur at the same time, an unstable value is shifted, that may result in generation of the pulse different from the programmed value until the next INTTCj interrupt request is generated.

Note 2: When the timer is stopped during PWM output, the  $\overline{\text{PWMj}}$  pin holds the output status when the timer is stopped. To change the output status, program TCjCR<TFFj> after the timer is stopped. Do not change the TCjCR<TFFj> upon stopping of the timer.

Example: Fixing the  $\overline{\text{PWMj}}$  pin to the high level when the TimerCounter is stopped

CLR (TCjCR).3: Stops the timer.

CLR (TCjCR).7: Sets the  $\overline{\text{PWMj}}$  pin to the high level.

Note 3: To enter the STOP mode during PWM output, stop the timer and then enter the STOP mode. If the STOP mode is entered without stopping the timer when fc or fc/2 is selected as the source clock, a pulse is output from the  $\overline{\text{PWMj}}$  pin during the warm-up period time after exiting the STOP mode.

Note 4: j = 5, 6

Table 12-4 PWM Output Mode

Source Clock		Resolution		Repeated Cycle	
NORMAL, IDLE mode		DV1CK = 0	DV1CK = 1	DV1CK = 0	DV1CK = 1
DV1CK = 0	DV1CK = 1	fc = 20 MHz	fc = 20 MHz	fc = 20 MHz	fc = 20 MHz
fc/2 <sup>11</sup> [Hz]	fc/2 <sup>12</sup> [Hz]	102.4 $\mu$ s	204.8 $\mu$ s	26.21 ms	52.43 ms
fc/2 <sup>7</sup>	fc/2 <sup>8</sup>	6.4 $\mu$ s	12.8 $\mu$ s	1.64 ms	3.28 ms
fc/2 <sup>5</sup>	fc/2 <sup>6</sup>	1.6 $\mu$ s	3.2 $\mu$ s	410 $\mu$ s	819 $\mu$ s
fc/2 <sup>3</sup>	fc/2 <sup>4</sup>	0.4 $\mu$ s	0.8 $\mu$ s	102 $\mu$ s	205 $\mu$ s

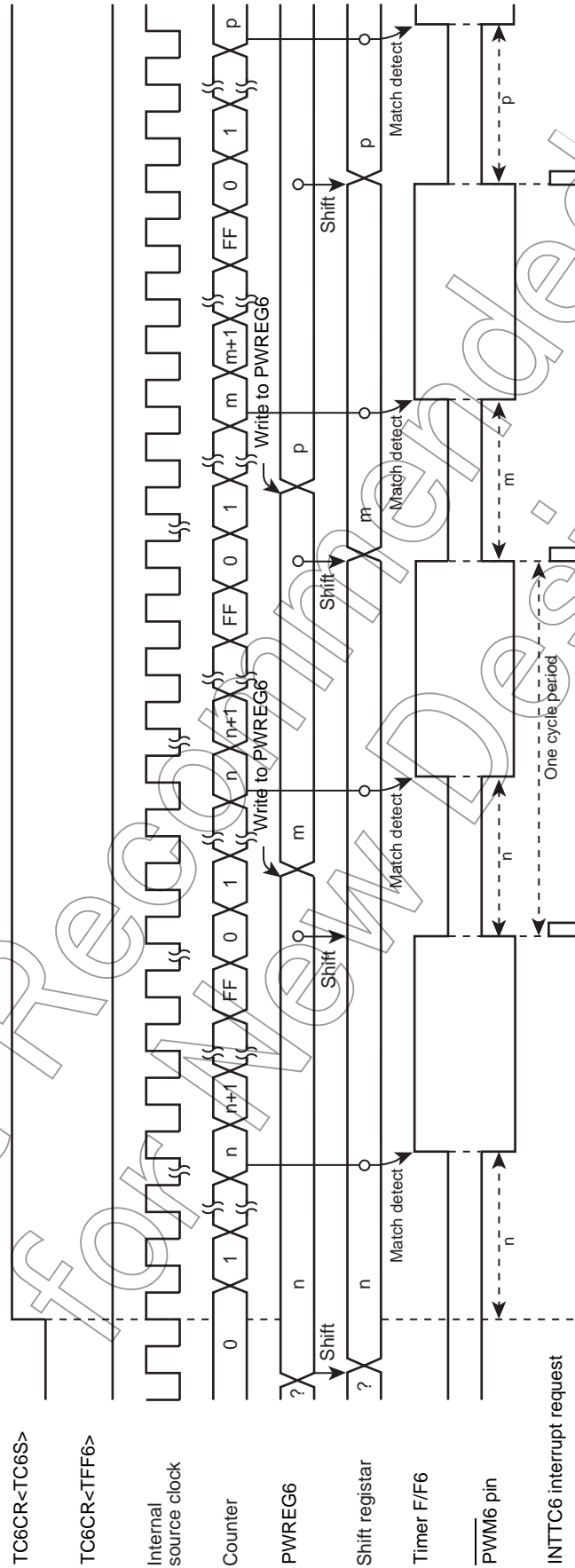

Figure 12-5 8-Bit PWM Mode Timing Chart (TC6)

### 12.3.5 16-Bit Timer Mode (TC5 and 6)

In the timer mode, the up-counter counts up using the internal clock. The TimerCounter 5 and 6 are cascadable to form a 16-bit timer.

When a match between the up-counter and the timer register (TTREG5, TTREG6) value is detected after the timer is started by setting TC6CR<TC6S> to 1, an INTTC6 interrupt is generated and the up-counter is cleared. After being cleared, the up-counter continues counting. Program the lower byte and upper byte in this order in the timer register. (Programming only the upper or lower byte should not be attempted.)

Note 1: In the timer mode, fix TCjCR<TFFj> to 0. If not fixed, the  $\overline{PDOj}$ ,  $\overline{PWMj}$ , and  $\overline{PPGj}$  pins may output a pulse.

Note 2: In the timer mode, do not change the TTREGj setting while the timer is running. Since TTREGj is not in the shift register configuration in the timer mode, the new value programmed in TTREGj is in effect immediately after programming of TTREGj. Therefore, if TTREGj is changed while the timer is running, an expected operation may not be obtained.

Note 3: j = 5, 6

Table 12-5 Source Clock for 16-Bit Timer Mode

Source Clock		Resolution		Maximum Time Setting	
NORMAL, IDLE mode		DV1CK = 0	DV1CK = 1	DV1CK = 0	DV1CK = 1
DV1CK = 0	DV1CK = 1	fc = 20 MHz	fc = 20 MHz	fc = 20 MHz	fc = 20 MHz
fc/2 <sup>11</sup>	fc/2 <sup>12</sup>	102.4 μs	204.8 μs	6.7 s	13.4 s
fc/2 <sup>7</sup>	fc/2 <sup>8</sup>	6.4 μs	12.8 μs	419.4 ms	838.8 ms
fc/2 <sup>5</sup>	fc/2 <sup>6</sup>	1.6 μs	3.2 μs	104.9 μs	209.7 ms
fc/2 <sup>3</sup>	fc/2 <sup>4</sup>	0.4 μs	0.8 μs	26.2 μs	52.4 ms

Example :Setting the timer mode with source clock  $fc/2^7$  [Hz], and generating an interrupt 240 ms later (fc = 20.0 MHz)

- LDW (TTREG5), 927CH : Sets the timer register (300 ms = 2<sup>7</sup>/fc = 927CH).
- DI
- SET (EIRD), EF28 : Enables INTTC6 interrupt.
- EI
- LD (TC5CR), 13H : Sets the operating clock to  $fc/2^7$ , and 16-bit timer mode (lower byte).
- LD (TC6CR), 04H : Sets the 16-bit timer mode (upper byte).
- LD (TC6CR), 0CH : Starts the timer.

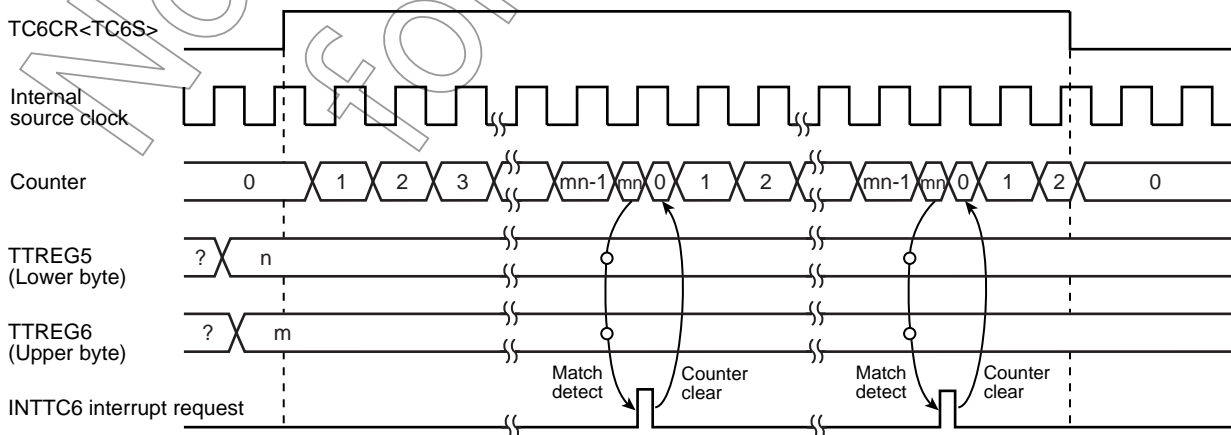

Figure 12-6 16-Bit Timer Mode Timing Chart (TC5 and TC6)



### 12.3.6 16-Bit Event Counter Mode (TC5 and 6)

In the event counter mode, the up-counter counts up at the falling edge to the TC5 pin. The TimerCounter 5 and 6 are cascadable to form a 16-bit event counter.

When a match between the up-counter and the timer register (TTREG5, TTREG6) value is detected after the timer is started by setting TC6CR<TC6S> to 1, an INTTC6 interrupt is generated and the up-counter is cleared.

After being cleared, the up-counter restarts counting at the falling edge of the input pulse to the TC5 pin. Two machine cycles are required for the low- or high-level pulse input to the TC5 pin.

Therefore, a maximum frequency to be supplied is  $f_c/2^4$  Hz in the NORMAL or IDLE mode. Program the lower byte (TTREG5), and upper byte (TTREG6) in this order in the timer register. (Programming only the upper or lower byte should not be attempted.)

Note 1: In the event counter mode, fix TCjCR<TFFj> to 0. If not fixed, the  $\overline{PDO}_j$ ,  $\overline{PWM}_j$  and  $\overline{PPG}_j$  pins may output pulses.

Note 2: In the event counter mode, do not change the TTREGj setting while the timer is running. Since TTREGj is not in the shift register configuration in the event counter mode, the new value programmed in TTREGj is in effect immediately after the programming. Therefore, if TTREGj is changed while the timer is running, an expected operation may not be obtained.

Note 3: j = 5, 6

### 12.3.7 16-Bit Pulse Width Modulation (PWM) Output Mode (TC5 and 6)

This mode is used to generate a pulse-width modulated (PWM) signals with up to 16 bits of resolution. The TimerCounter 5 and 6 are cascadable to form the 16-bit PWM signal generator.

The counter counts up using the internal clock or external clock.

When a match between the up-counter and the timer register (PWREG5, PWREG6) value is detected, the logic level output from the timer F/F6 is switched to the opposite state. The counter continues counting. The logic level output from the timer F/F6 is switched to the opposite state again by the counter overflow, and the counter is cleared. The INTTC6 interrupt is generated at this time.

Two machine cycles are required for the high- or low-level pulse input to the TC5 pin. Therefore, a maximum frequency to be supplied is  $f_c/2^4$  Hz in the NORMAL1 or IDLE1 mode.

Since the initial value can be set to the timer F/F6 by TC6CR<TFF6>, positive and negative pulses can be generated. Upon reset, the timer F/F6 is cleared to 0.

(The logic level output from the  $\overline{PWM}_6$  pin is the opposite to the timer F/F6 logic level.)

Since PWREG6 and 5 in the PWM mode are serially connected to the shift register, the values set to PWREG6 and 5 can be changed while the timer is running. The values set to PWREG6 and 5 during a run of the timer are shifted by the INTTCj interrupt request and loaded into PWREG6 and 5. While the timer is stopped, the values are shifted immediately after the programming of PWREG6 and 5. Set the lower byte (PWREG5) and upper byte (PWREG5) in this order to program PWREG6 and 5. (Programming only the lower or upper byte of the register should not be attempted.)

If executing the read instruction to PWREG6 and 5 during PWM output, the values set in the shift register is read, but not the values set in PWREG6 and 5. Therefore, after writing to the PWREG6 and 5, reading data of PWREG6 and 5 is previous value until INTTC6 is generated.

For the pin used for PWM output, the output latch of the I/O port must be set to 1.

Note 1: In the PWM mode, program the timer register PWREG6 and 5 immediately after the INTTC6 interrupt request is generated (normally in the INTTC6 interrupt service routine.) If the programming of PWREGj and the interrupt request occur at the same time, an unstable value is shifted, that may result in generation of pulse different from the programmed value until the next INTTC6 interrupt request is generated.

Note 2: When the timer is stopped during PWM output, the  $\overline{PWM}_6$  pin holds the output status when the timer is stopped. To change the output status, program TC6CR<TFF6> after the timer is stopped. Do not program TC6CR<TFF6> upon stopping of the timer.

Example: Fixing the  $\overline{PWM}_6$  pin to the high level when the TimerCounter is stopped

CLR (TC6CR).3: Stops the timer.

CLR (TC6CR).7 : Sets the  $\overline{PWM}_6$  pin to the high level.

Note 3: To enter the STOP mode, stop the timer and then enter the STOP mode. If the STOP mode is entered without stopping of the timer when  $f_c$  or  $f_c/2$  is selected as the source clock, a pulse is output from the PWM6 pin during the warm-up period time after exiting the STOP mode.

Table 12-6 16-Bit PWM Output Mode

Source Clock		Resolution		Repeated Cycle	
NORMAL, IDLE mode		DV1CK = 0	DV1CK = 1	DV1CK = 0	DV1CK = 1
DV1CK = 0	DV1CK = 1	$f_c = 20\text{MHz}$	$f_c = 20\text{MHz}$	$f_c = 20\text{MHz}$	$f_c = 20\text{MHz}$
$f_c/2^{11}$ [Hz]	$f_c/2^{12}$ [Hz]	102.4 $\mu\text{s}$	204.8 $\mu\text{s}$	6.7 s	13.4 s
$f_c/2^7$	$f_c/2^8$	6.4 $\mu\text{s}$	12.8 $\mu\text{s}$	419.4 ms	838.8 ms
$f_c/2^5$	$f_c/2^6$	1.6 $\mu\text{s}$	3.2 $\mu\text{s}$	104.9 ms	209.7 ms
$f_c/2^3$	$f_c/2^4$	0.4 $\mu\text{s}$	0.8 $\mu\text{s}$	26.2 ms	52.4 ms

Example :Generating a pulse with 1-ms high-level width and a period of 32.768 ms ( $f_c = 20.0\text{MHz}$ )

Setting ports

LDW (PWREG5), 07D0H : Sets the pulse width.

LD (TC5CR), 33H : Sets the operating clock to  $f_c/2^3$ , and 16-bit PWM output mode (lower byte).

LD (TC6CR), 056H : Sets TFF6 to the initial value 0, and 16-bit PWM signal generation mode (upper byte).

LD (TC6CR), 05EH : Starts the timer.

Not Recommended for New Design

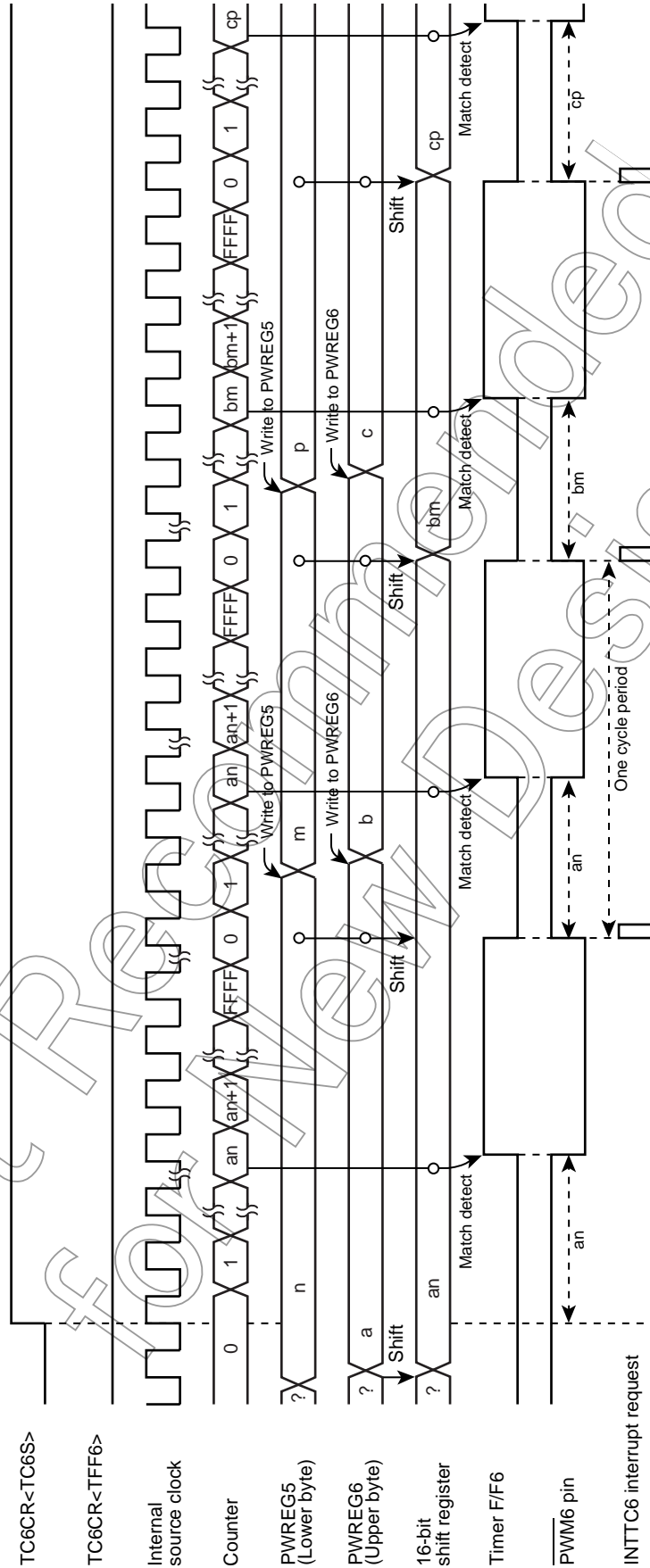

Figure 12-7 16-Bit PWM Mode Timing Chart (TC5 and TC6)

### 12.3.8 16-Bit Programmable Pulse Generate (PPG) Output Mode (TC5 and 6)

This mode is used to generate pulses with up to 16-bits of resolution. The timer counter 5 and 6 are cascaded to enter the 16-bit PPG mode.

The counter counts up using the internal clock or external clock. When a match between the up-counter and the timer register (PWREG5, PWREG6) value is detected, the logic level output from the timer F/F6 is switched to the opposite state. The counter continues counting. The logic level output from the timer F/F6 is switched to the opposite state again when a match between the up-counter and the timer register (TTREG5, TTREG6) value is detected, and the counter is cleared. The INTTC6 interrupt is generated at this time.

Since the initial value can be set to the timer F/F6 by TC6CR<TFF6>, positive and negative pulses can be generated. Upon reset, the timer F/F6 is cleared to 0.

(The logic level output from the  $\overline{\text{PPG6}}$  pin is the opposite to the timer F/F6.)

Set the lower byte and upper byte in this order to program the timer register. (TTREG5 → TTREG6, PWREG5 → PWREG6) (Programming only the upper or lower byte should not be attempted.)

For PPG output, set the output latch of the I/O port to 1.

Example :Generating a pulse with 1-ms high-level width and a period of 16.385 ms ( $f_c = 20.0 \text{ MHz}$ )

Setting ports		
LDW	(PWREG5), 07D0H	: Sets the pulse width.
LDW	(TTREG5), 8002H	: Sets the cycle period.
LD	(TC5CR), 33H	: Sets the operating clock to $f_c/2^3$ , and 16-bit PPG mode (lower byte).
LD	(TC6CR), 057H	: Sets TFF6 to the initial value 0, and 16-bit PPG mode (upper byte).
LD	(TC6CR), 05FH	: Starts the timer.

Note 1: In the PPG mode, do not change the PWREGi and TTREGi settings while the timer is running. Since PWREGi and TTREGi are not in the shift register configuration in the PPG mode, the new values programmed in PWREGi and TTREGi are in effect immediately after programming PWREGi and TTREGi. Therefore, if PWREGi and TTREGi are changed while the timer is running, an expected operation may not be obtained.

Note 2: When the timer is stopped during PPG output, the  $\overline{\text{PPG6}}$  pin holds the output status when the timer is stopped. To change the output status, program TC6CR<TFF6> after the timer is stopped. Do not change TC6CR<TFF6> upon stopping of the timer.

Example: Fixing the  $\overline{\text{PPG6}}$  pin to the high level when the TimerCounter is stopped

CLR (TC6CR).3: Stops the timer

CLR (TC6CR).7: Sets the  $\overline{\text{PPG6}}$  pin to the high level

Note 3:  $i = 5, 6$

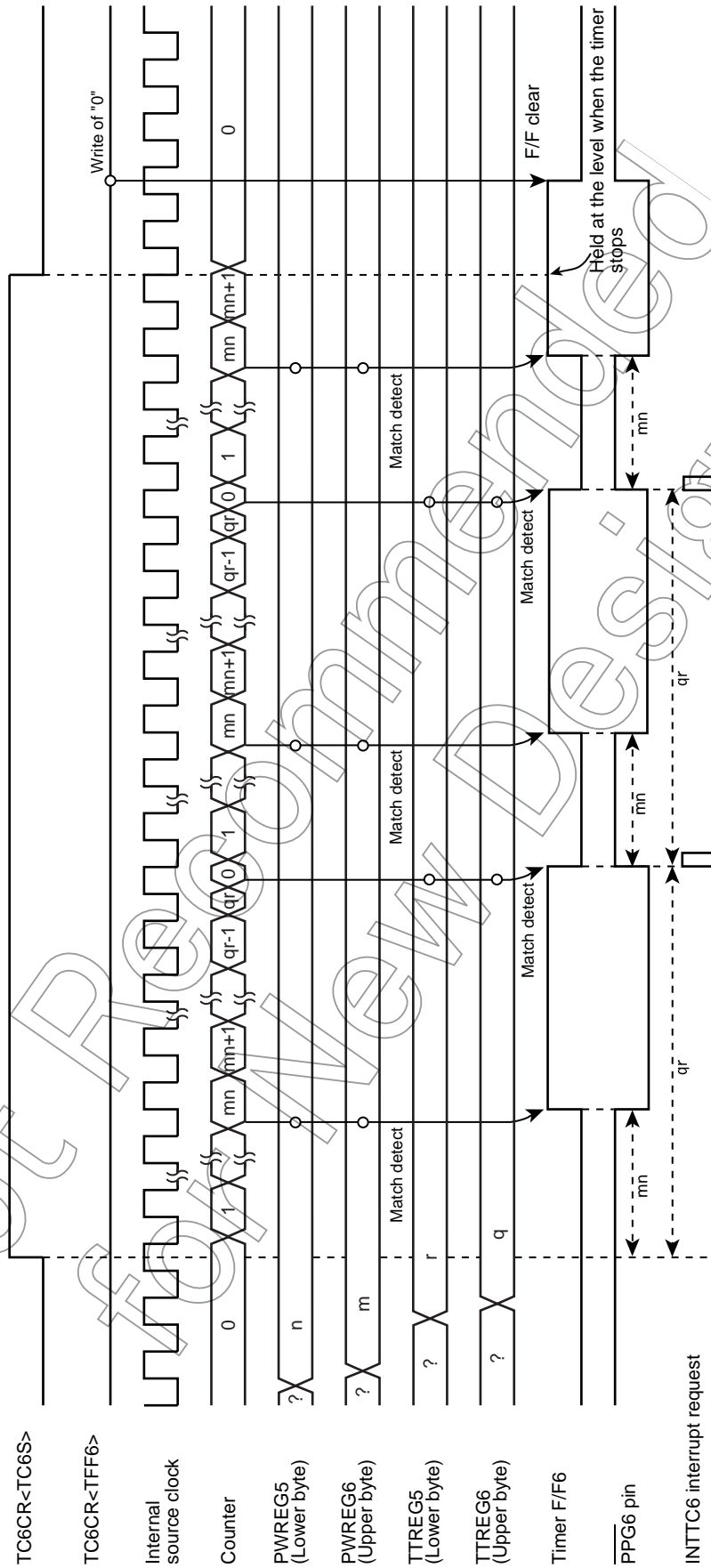

Figure 12-8 16-Bit PPG Mode Timing Chart (TC5 and TC60)

## 13. Motor Control Circuit (PMD: Programmable motor driver)

The TMP88CS42NG contains two channels of motor control circuits used for sinusoidal waveform output. This motor control circuit can control brushless DC motors or AC motors with or without sensors. With its primary functions like those listed below incorporated in hardware, it helps to accomplish sine wave motor control easily, with the software load significantly reduced.

1. Rotor position detect function
  - Can detect the rotor position, with or without sensors
  - Can be set to determine the rotor position when detection matched a number of times, to prevent erroneous detection
  - Can set a position detection inhibit period immediately after PWM-on
2. Independent timer and timer capture functions for motor control
  - Contains one-channel magnitude comparison timer and two-channel coincidence comparison timers that operate synchronously for position detection
3. PWM waveform generating function
  - Generates 12-bit PWM with 100 ns resolution
  - Can set a frequency of PWM interrupt occurrence
  - Can set the dead time at PWM-on
4. Protective function
  - Provides overload protective function based on protection signal input
5. Emergency stop function in case of failure
  - Can be made to stop in an emergency by EMG input or timer overflow interrupt
  - Not easily cleared by software runaway
6. Auto commutation/Auto position detection start function
  - Comprised of dual-buffers, can activate auto commutation synchronously with position detection or timer
  - Can set a position detection period using the timer function and start auto position detection at the set time
7. Electrical angle timer function
  - Can count 360 degrees of electrical angle with a set period in the range of 0 to 383
  - Can output the counted electrical angle to the waveform arithmetic circuit
8. Waveform arithmetic circuit
  - Calculate the output duty cycle from the sine wave data and voltage data which are read from the RAM based on the electrical angle timer
  - Output the calculation result to the waveform synthesis circuit

## 13.1 Outline of Motor Control

The following explains the method for controlling a brushless DC motor with sine wave drive. In a brushless DC motor, the rotor windings to which to apply electric current are determined from the rotor's magnetic pole position, and the current-applied windings are changed as the rotor turns. The rotor's magnetic pole position is determined using a sensor such as a hall IC or by detecting polarity change (zero-cross) points of the induced voltage that develops in the motor windings (sensorless control). For the sensorless case, the induced voltage is detected by applying electric current to two phases and not applying electric current to the remaining other phase. In this two-phase current on case, there are six current application patterns as shown in Table 13-1, which are changed synchronously with the phases of the rotor. In this two-phase current on case, the current on time in each phase is 120 degrees relative to 180 degrees of the induced voltage.

Table 13-1 Current Application Patterns

Current Application Pattern	Upper Transistor			Lower Transistor			Current on Winding
	u	v	w	x	y	z	
Mode 0	ON	OFF	OFF	OFF	ON	OFF	U→V
Mode 1	ON	OFF	OFF	OFF	OFF	ON	U→W
Mode 2	OFF	ON	OFF	OFF	OFF	ON	V→W
Mode 3	OFF	ON	OFF	ON	OFF	OFF	V→U
Mode 4	OFF	OFF	ON	ON	OFF	OFF	W→U
Mode 5	OFF	OFF	ON	OFF	ON	OFF	W→V

Note: One of the upper or lower transistors is PWM controlled.

For brushless DC motors, the number of revolutions is controlled by an applied voltage, and the voltage application is controlled by PWM. At this time, the current on windings need to be changed in synchronism with the phases of the voltage induced by revolutions. Control timing in cases where the current on windings are changed by means of sensorless control is illustrated in Figure 13-4. For three-phase motors, zero-crossing occurs six times during one cycle of the induced voltage (electrical angle 360 degrees), so that the electrical angle from one zero-cross point to the next is 60 degrees. Assuming that this period comprises one mode, the rotor position can be divided into six modes by zero-cross points. The six current application patterns shown above correspond one for one to these six modes. The timing at which the current application patterns are changed (commutation) is out of phase by 30 degrees of electrical angle, with respect to the position detection by an induced voltage.

Mode time is obtained by detecting a zero-cross point at some timing and finding an elapsed time from the preceding zero-cross point. Because mode time corresponds to 60 degrees of electrical angle, the following applies for the case illustrated in Figure 13-4.

1. Current on windings changeover (commutation) timing  
30 degrees of electrical angle = mode time/2
2. Position detection start timing 45 degrees of electrical angle = mode time × 3/4
3. Failure determination timing 120 degrees of electrical angle = mode time × 2

Timings are calculated in this way. The position detection start timing in 2 is needed to prevent erroneous detection of the induced voltage for reasons that even after current application is turned off, the current continues flowing due to the motor reactance.

Control is exercised by calculating the above timings successively for each of the zero-cross points detected six times during 360 degrees of electrical angle and activating commutation, position detection start, and other operations according to that timing.

In this way, operations can be synchronized to the phases of the induced voltage of the motor.

The timing needed for motor control as in this example can be set freely as desired by using the internal timers of the microcontroller's PMD unit.

Also, sine wave control requires controlling the PWM duty cycle for each pulse. Control of PWM duty cycles is accomplished by counting degrees of electrical angle and calculating the sine wave data and voltage data at the counted degree of electrical angle.

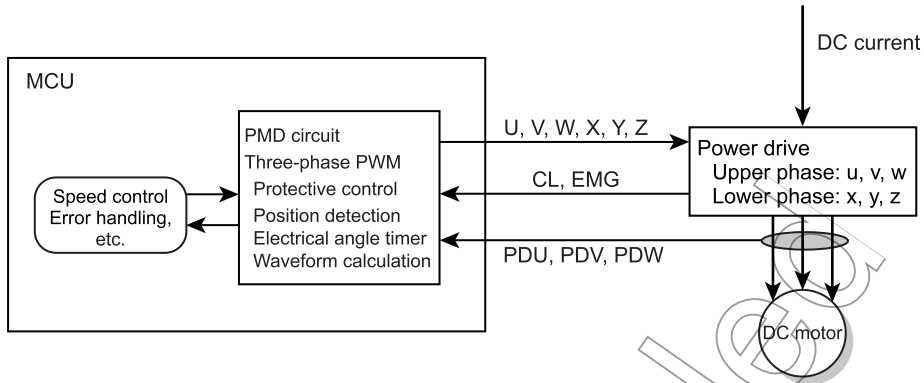

Figure 13-1 Conceptual Diagram of DC Motor Control

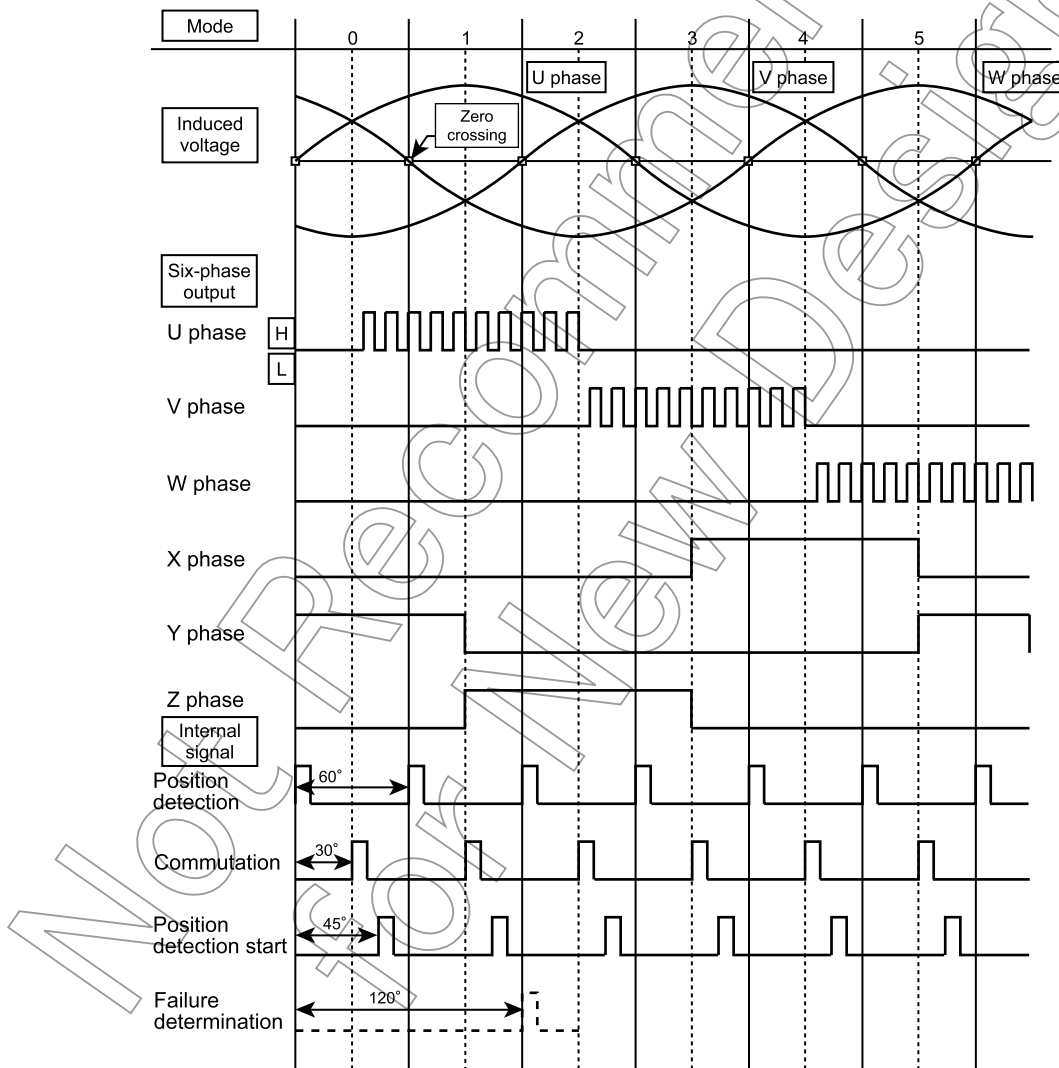

Figure 13-2 Example of Sensorless DC Motor Control Timing Chart



## 13.2 Configuration of the Motor Control Circuit

The motor control circuit consists of various units. These include a position detection unit to detect the zero-cross points of the induced voltage or position sensor signal, a timer unit to generate events at three instances of electrical angle timing, and a three-phase PWM output unit to produce three-phase output PWM waveforms. Also included are an electrical angle timer unit to count degrees of electrical angle and a waveform arithmetic unit to calculate sinusoidal waveform output duty cycles. The input/output units are configured as shown in the diagram below. When using ports for the PMD function, set the Port input/output control register (P3CRi and P5CRi) to 0 for the input ports, and for the output ports, set the data output latch (P3i and P5i) to 1 and then the port input/output control register to 1. Other input/output ports can be set in the same way for use of the PMD function.

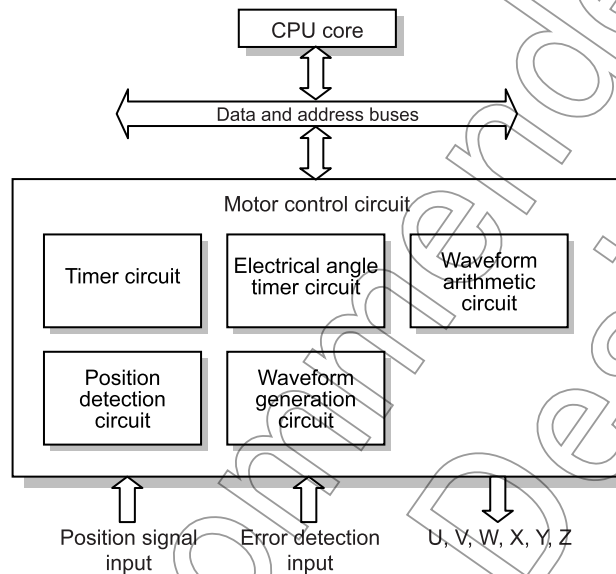

Figure 13-3 Block Diagram of the Motor Control Circuit

Note 1: Always use the LDW instruction to set data in the 9, 12 and 16-bit data registers.

Note 2: The EMG circuit initially is enabled. For PMD output, fix the EMG input port (P36 and P51) "H" high level or disable the EMG circuit before using for PMD output.

Note 3: The EMG circuit initially is enabled. When using Port P3 and P5 as input/output IO ports, disable EMG.

Note 4: When going to STOP mode, be sure to turn all of the PMD functions off before entering STOP mode.

### 13.3 Position Detection Unit

The Position Detection Unit identifies the motor's rotor position from input patterns on the position signal input port. Applied to this position signal input port is the voltage status of the motor windings for the case of sensorless DC motors or a Hall element signal for the case of DC motors with sensors included. The expected patterns corresponding to specific rotor positions are set in the PMD Output Register (MDOUT) beforehand, and when the input position signal and the expected value match as the rotation, a position detection interrupt (INTPDC) is generated. Also, unmatched detection mode is used to detect the direction of motor rotation, where when the status of the position detection input port changes from the status in which it was at start of sampling, a position detection interrupt is generated.

For three-phase brushless DC motors, there are six patterns of position signals, one for each mode, as summarized in Table 13-2 from the timing chart in Figure 13-2. Once a predicted position signal pattern is set in the MDOUT register, a position detection interrupt is generated the moment the position signal input port goes to mode indicated by this expected value. The position signals at each phase in the diagram are internal signals which cannot be observed from the outside.

Table 13-2 Position Signal Input Patterns

Position Detection Mode	U Phase (PDU)	V Phase (PDV)	W Phase (PDW)
Mode 0	H	L	H
Mode 1	H	L	L
Mode 2	H	H	L
Mode 3	L	H	L
Mode 4	L	H	H
Mode 5	L	L	H

Not Recommended for New Design

## 13.3.1 Configuration of the position detection unit

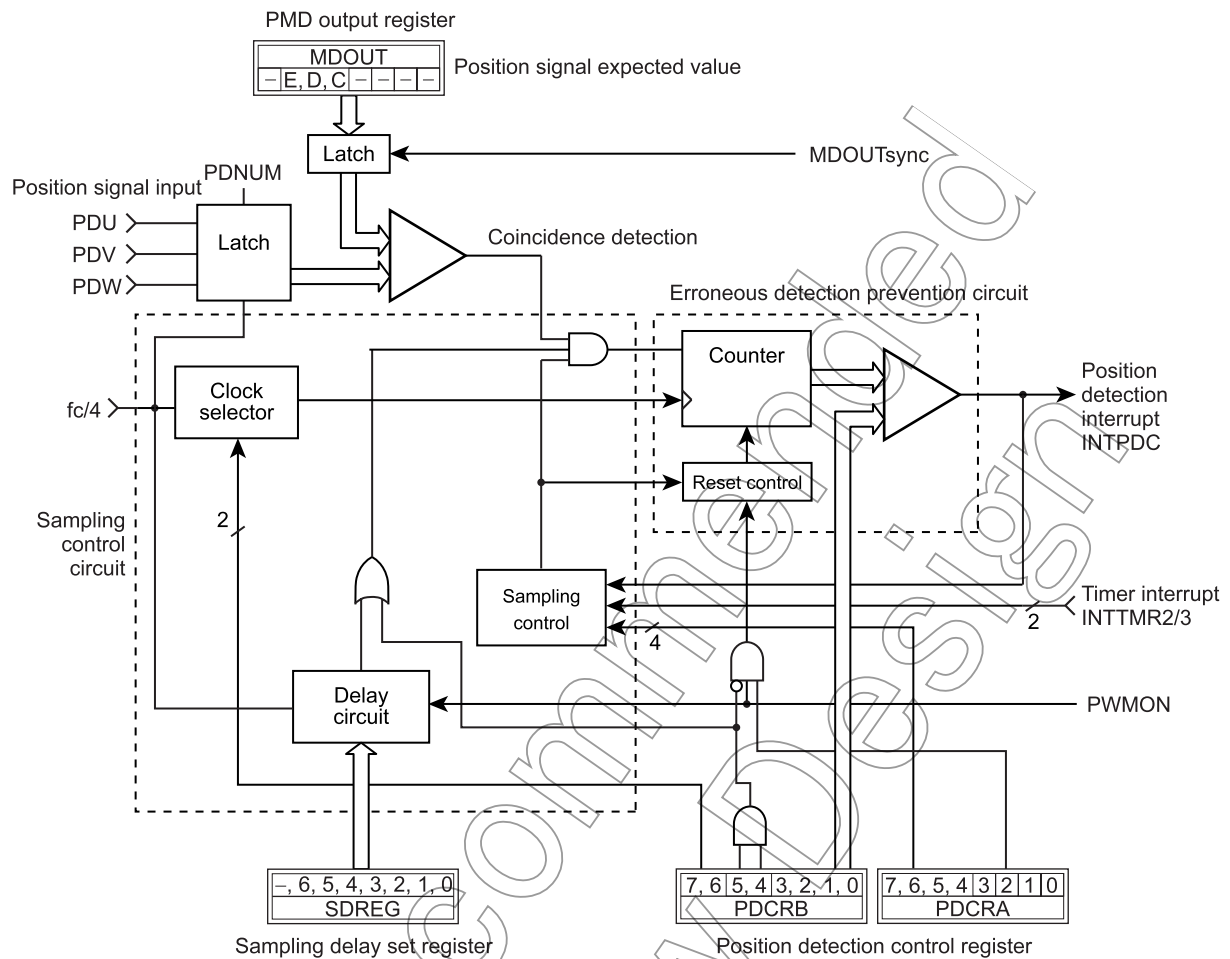

Figure 13-4 Configuration of the Position Detection Circuit

- The position detection unit is controlled by the Position Detection Control Register (PDCRA, PDCRB). After the position detection function is enabled, the unit starts sampling the position detection port with Timer 2 or in software. For the case of ordinary mode, when the status of the position detection input port matches the expected value of the PMD Output Register, the unit generates a position detection interrupt and finishes sampling, waiting for start of the next sampling.
- When unmatch detection mode is selected for position detection, the unit stores the sampled status of the position detection port in memory at the time it started sampling. When the port input status changes from the status in which it was at start of sampling, an interrupt is generated.
- In unmatch detection mode, the port status at start of sampling can be read (PDCRC<PDTCT>).
- When starting and stopping position detection synchronously with the timer, position detection is started by Timer 2 and position detection is stopped by Timer 3.
- Sampling mode can be selected from three modes available: mode where sampling is performed only while PWM is on, mode where sensors such as Hall elements are sampled regularly, and mode where sampling is performed while the lower side is conducting current (when performing sampling only while PWM is on, DUTY must be set for all three phases in common).
- When sampling mode is selected for detecting position while the lower phases are conducting current, sampling is performed for a period from when the set sampling delay time has elapsed after the lower side started conducting current till when the current application is turned off. Sampling is performed independently at each phase, and the sampling result is retained while sampling is idle. If while sampling at some phase is idle, the input and the expected value at other phase being sampled match, position is detected and an interrupt is generated.

- A sampling delay is provided for use in modes where sampling is made while PWM is on or the lower phases are conducting current. It helps to prevent erroneous detection due to noise that occurs immediately after the transistor turns on, by starting sampling a set time after the PWM signal turned on.
- When detecting position while PWM is on or the lower phases are conducting current, a method can be selected whether to recount occurrences of matched position detection after being compared for each PWM signal on (logical sum of three-phase PWM signals) (e.g., starting from 0 in each PWM cycle) or counting occurrences of matching continuously (PDCRB<SPLMD> is used to enable/disable recounting occurrences of matching while PWM is on).

### 13.3.2 Position Detection Circuit Register Functions

PDCRC

5, 4	EMEM	Hold result of position detection at PWM edge (Detect position detected position)	These bits hold the comparison result of position detection at falling or rising edge of PWM pulse. Bits 5 and 4 are set to 1 when position is detected at the falling or the rising edge, respectively. They show whether position is detected in the current PWM pulse, during PWM off, or in the immediately preceding PWM pulse.
3	SMON	Monitor sampling status	When read, this bit shows the sampling status.
2 to 0	PDTCT	Hold position signal input status	This bit holds the status of the position signal input at the time position detection started in unmatch mode.

PDCRB

7, 6	SPLCK	Sampling period	Select $fc/2^2$ , $fc/2^3$ , $fc/2^4$ , or $fc/2^5$ for the position detection sampling period.
5, 4	SPLMD	Sampling mode	Select one of three modes: sampling only when PWM signal is active (when PWM is on), sampling regularly, or sampling when the lower side (X, Y, Z) phases are conducting current.
3 to 0	PDCMP	Sampling count	In ordinary mode, when the port status and the set expected value match and continuously match as many times as the sampling counts set, a position detection signal is output and an interrupt is generated. In unmatch detection mode, when the said status and value do not match and continuously unmatch as many times as the sampling counts set, a position detection signal is output and an interrupt is generated.

PDCRA

7	SWSTP	Stop sampling in software	Sampling can be stopped in software by setting this bit to 1 (e.g., by writing to this register). Sampling is performed before stopping and when position detection results match, a position detection interrupt is generated, with sampling thereby stopped.
6	SWSTT	Start sampling in software	Sampling can be started by setting this bit to 1 (e.g., by writing to this register).
5	SPTM3	Stop sampling using Timer 3	Sampling can be stopped by a trigger from Timer 3 by setting this bit to 1. Sampling is performed before stopping and when position detection results match, a position detection interrupt is generated, with sampling thereby stopped.
4	STTM2	Start sampling using Timer 2	Sampling can be started by a trigger from Timer 3 by setting this bit to 1.
3	PDNUM	Number of position signal input pins	Select whether to use three pins (PDU/PDV/PDW) or one pin (PDU only) for position signal input. When one pin is selected, the expected values of PDV and PDW are ignored. When performing position detection with two pins or a pin other than PDU, position signal input can be masked as 0 by setting unused pin(s) for output.
2	RCEN	Recount occurrences of matching when PWM is on	When performing sampling while PWM is on, occurrences of matching are recounted each time PWM signal turns on by setting this bit to 1 (when recounting occurrences of matching, the count is reset each time PWM turns off). When this bit is set to 0, occurrences of matching are counted continuously regardless PWM interval.
1	DTMD	Position detection mode	Setting this bit to 0 selects ordinary mode where position is detected when the expected value set in the register and the port input unmatch and then match. Setting this bit to 1 selects unmatch detection mode where position is detected at the time the port status changes to another one from the status in which it was when sampling started.
0	PDCEN	Position detection function	The position detection function is activated by setting this bit to 1.

SDREG

6 to 0	SDREG	Sampling delay	Set a time for which to stop sampling in order to prevent erroneous detection due to noise that occurs immediately after PWM output turns on (immediately after the transistor turns on). (Figure 13-5)
--------	-------	----------------	---

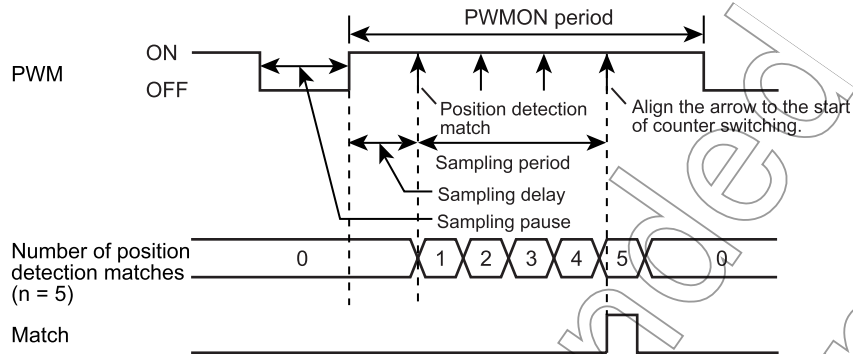

Figure 13-5 Position Detection Sampling Timing with the PWMON Period Selected

EMEM: Detects when a position detection match has occurred (the value is held after position detection). (Check on whether sampling has started on the previous pulse)

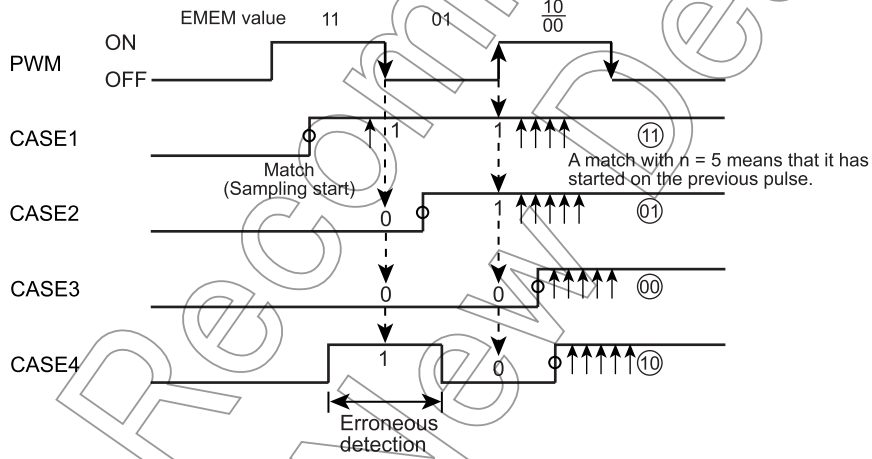

Figure 13-6 Detection Timing of the Position Detection Position

Position Detection Circuit Registers [Addresses (PMD1 and PMD2)]

PDCRC (01FA2H) (01FD2H)	7	6	5	4	3	2	1	0	(Initial value: **00 0000)
	-	-	EMEM	SMON	PDTCT				

5, 4	EMEM	Hold result of position detection at PWM edge (Detect position detected position)	00: Detected in the current pulse 01: Detected while PWM off 10: Detected in the current pulse 11: Detected in the preceding pulse	R
3	SMON	Monitor sampling status	0: Sampling idle 1: Sampling in progress	
2 to 0	PDTCT	Hold position signal input status	Holds the status of the position signal input during unmatched detection mode. Bits 2 to 0 correspond to W, V, and U phases.	

PDCRB (01FA1H) (01FD1H)	7	6	5	4	3	2	1	0	(Initial value: 0000 0000)
	SPLCK		SPLMD		PDCMP				

7, 6	SPLCK	Select sampling input clock	00: $fc/2^2$ [Hz] (200 ns at 20 MHz) 01: $fc/2^3$ (400 ns at 20 MHz) 10: $fc/2^4$ (800 ns at 20 MHz) 11: $fc/2^5$ (1.6 $\mu$ s at 20 MHz)	R/W
5, 4	SPLMD	Sampling mode	00: Sample when PWM is on 01: Sample regularly 10: Sample when lower phases conducting current 11: Reserved	
3 to 0	PDCMP	Position detection matched counts	1 to 15 times (Counts 0 and 1 are assumed to be one time.)	

Note: When changing setting, keep the PDCEN bit reset to "0" (disable position detection function).

PDCRA (01FA0H) (01FD0H)	7	6	5	4	3	2	1	0	(Initial value: 0000 0000)
	SWSTP	SWSTT	SPTM3	STTM2	PDNUM	RCEN	DTMD	PDCEN	

7	SWSTP	Stop sampling in software	0: No operation 1: Stop sampling	W
6	SWSTT	Start sampling in software	0: No operation 1: Start sampling	
5	SPTM3	Stop sampling using Timer 3	0: Disable 1: Enable	R/W
4	STTM2	Start sampling using Timer 2	0: Disable 1: Enable	
3	PDNUM	Number of position signal input pins	0: Compare three pins (PDU/PDV/PDW) 1: Compare one pin (PDU) only	
2	RCEN	Recount occurrences of matching when PWM is on	0: Continue counting from previously PWM on 1: Recount each time PWM turns on	
1	DTMD	Position detection mode	0: Ordinary mode 1: Unmatch detection mode	
0	PDCEN	Enable/Disable position detection function	0: Disable 1: Enable (Sampling starts)	

Note: Read-modify-write instructions, such as a bit manipulation instruction, cannot access the PDCRA because it contains a write only bit.

SDREG (01FA3H) (01FD3H)	7	6	5	4	3	2	1	0	(Initial value: *000 0000)
	-	D6	D5	D4	D3	D2	D1	D0	

6 to 0	SDREG	Sampling delay	$2^3/f_c \times n$ bits (n = 0 to 6, maximum 50.8 $\mu$ s, resolution of 400 ns at 20 MHz)	R/W
--------	-------	----------------	--	-----

Note: When changing setting, keep the PDCEN bit reset to "0" (disable position detection function).

### 13.3.3 Outline Processing in the Position Detection Unit

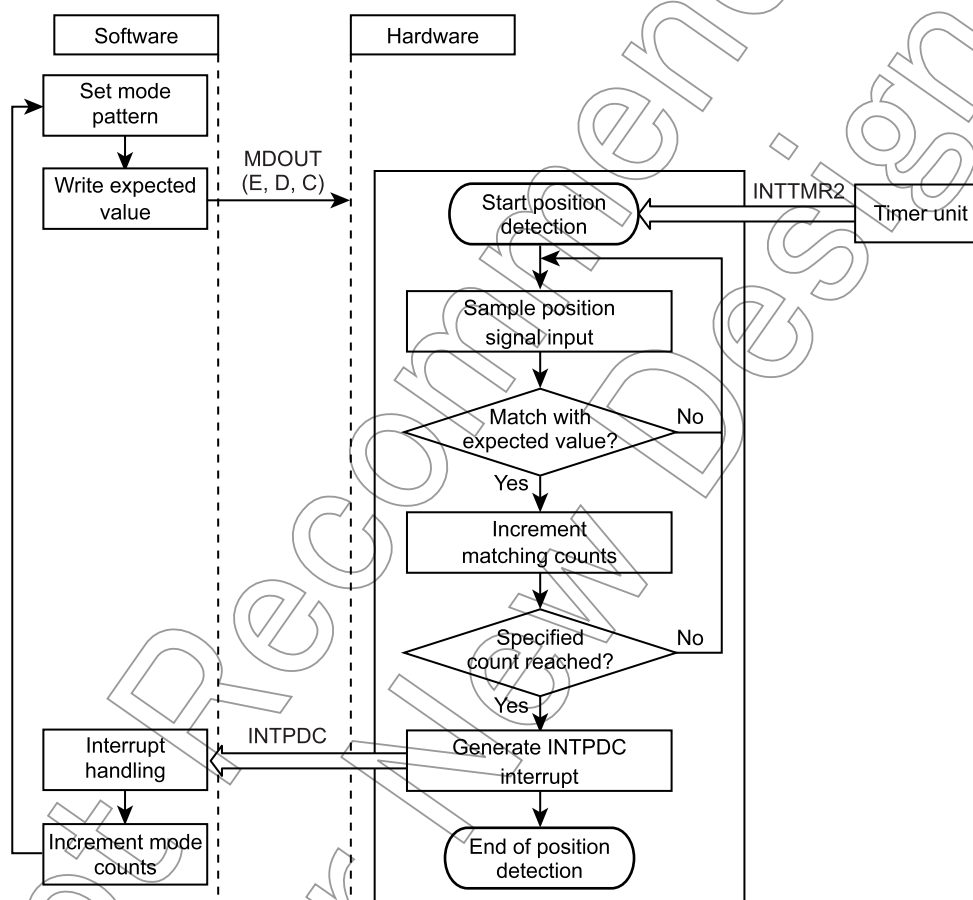

13.4 Timer Unit

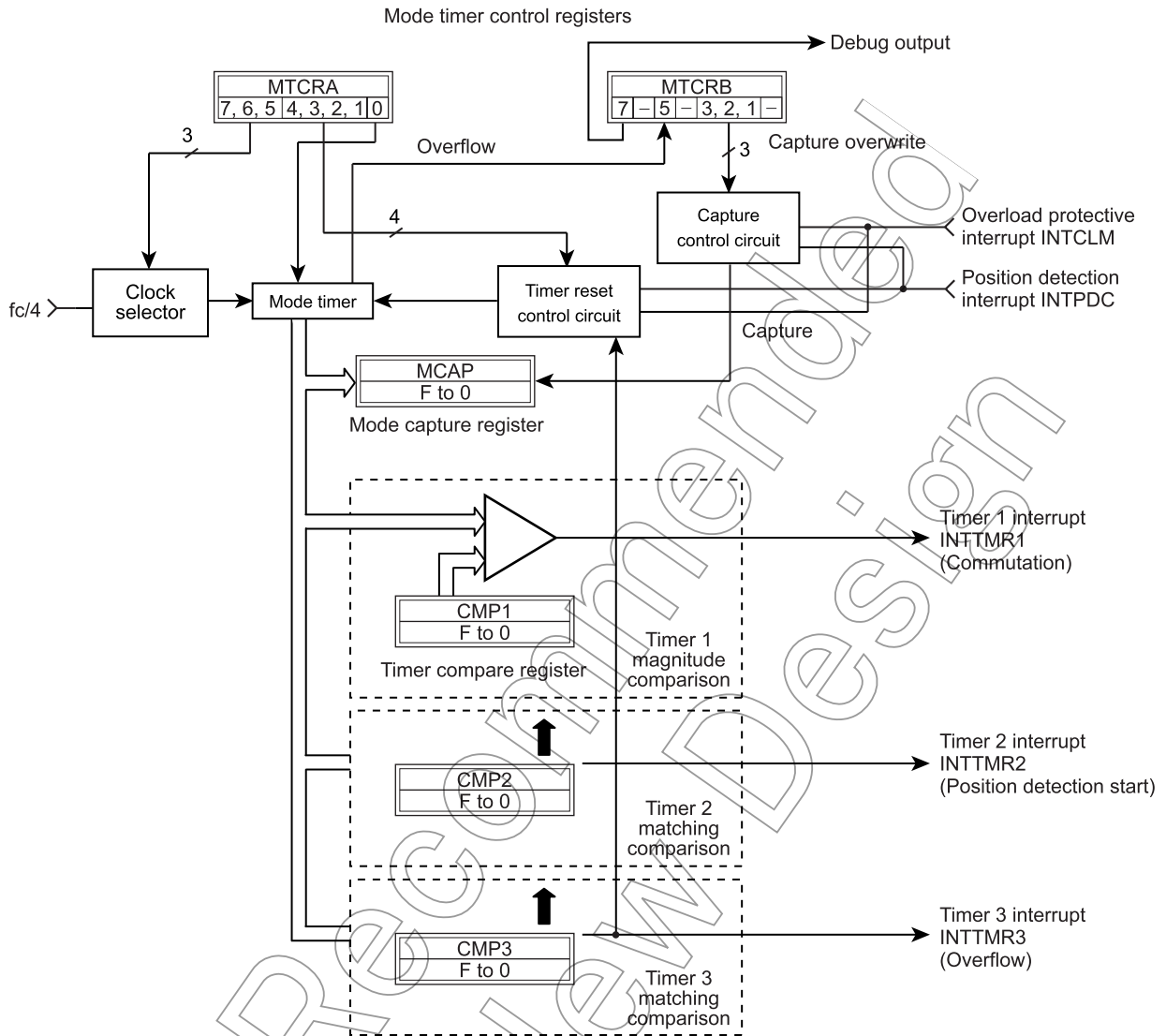

Figure 13-7 Timer Circuit Configuration

The timer unit has an up counter (mode timer) which is cleared by a position detection interrupt (INTPDC). Using this counter, it can generate three types of timer interrupts (INTTMR1 to 3). These timer interrupts may be used to produce a commutation trigger, position detection start trigger, etc. Also, the mode timer has a capture function which automatically captures register data in synchronism with position detection or overload protection. This capture function allows motor revolutions to be calculated by measuring position detection intervals.



### 13.4.1 Configuration of the Timer Unit

The timer unit consists mainly of a mode timer, three timer comparator, and mode capture register, and is controlled by timer control registers and timer compare registers.

- The mode timer can be reset by a signal from the position detection circuit, Timer 3, or overload protective circuit. If the mode timer overflows without being reset, it stops at FFFFH and sets an overflow flag in the control register.
- The value of the mode timer during counting can be read by capturing the count in software and reading the capture register.
- Timer 1 and Timers 2 and 3 generate an interrupt signal by magnitude comparison and matching comparison, respectively. Therefore, Timer 1 can generate an interrupt signal even when it could not write to the compare register in time and the counter value at the time of writing happens to exceed the register's set value.
- When any one of Timers 1 to 3 interrupts occurs, the next interrupts can be enabled by writing a new value to the respective compare registers (CMP1, CMP2, CMP3).
- When capturing by position detection is enabled, the capture register has the timer value captured in it each time position is detected. In this way, the capture register always holds the latest value.

Not Recommended for New Design

13.4.1.1 Timer Circuit Register Functions

MTCRB

7	DBOUT	Debug output	Debug output can be produced by setting this bit to 1. Because interrupt signals to the interrupt control circuit are used for each interrupt, hardware debugging without software delays are possible. See the debug output diagram (Figure 13-8). Output ports: P67 for PMD1, P77 for PMD2.
5	TMOF	Mode timer overflow	This bit shows that the timer has overflowed.
3	CLCP	Capture mode timer by overload protection	When this bit is set to 1, the timer value can be captured using the overload protection signal (CL) as a trigger.
2	SWCP	Capture mode timer in software	When this bit is set to 1, the timer value can be captured in software (e.g., by writing to this register).
1	PDCCP	Capture mode timer by position detection	When this bit is set to 1, the timer value can be captured using the position detection signal as a trigger.

MTCRA

7, 6, 5	TMCK	Select clock	Select the timer clock.
4	RBTM3	Reset mode timer from Timer 3	When this bit is set to 1, the mode timer is reset by a trigger from Timer 3.
3	RBCL	Reset mode timer by overload protection	When this bit is set to 1, the mode timer is reset by the overload protection signal (CL) as a trigger.
2	SWRES	Reset mode timer in software	When this bit is set to 1, the mode timer is reset in software (e.g., by writing to this register).
1	RBPDC	Reset mode timer by position detection	When this bit is set to 1, the mode timer is reset by the position detection signal as a trigger.
0	TMEN	Enable/disable mode timer	The mode timer is started by setting this bit to 1. Therefore, Timers 1 to 3 must be set with CMP before setting this bit. If this bit is set to 0 after setting CMP, CMP settings become ineffective.

MCAP	Mode capture	Position detection interval can be read out.
------	--------------	--

CMP1	Timer 1 (commutation)	Timers 1 to 3 are enabled while the mode timer is operating. An interrupt can be generated once by setting the corresponding bit in this register. The interrupt is disable when an interrupt is generated or the timer is reset. To use the timer again, set the register back again even if data is same.
CMP2	Timer 2 (position detection start)	
CMP3	Timer 3 (overflow)	

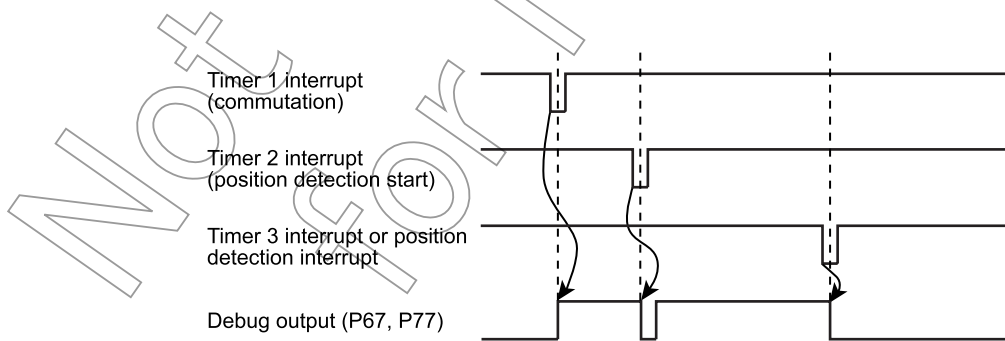

Figure 13-8 DBOUT Debug Output Diagram

Timer Circuit Registers [Addresses (PMD1 and PMD2)]

MTCRB (01FA5H) (01FD5H)	7	6	5	4	3	2	1	0	(Initial value: 0*0*0 000*)
	DBOUT	-	TMOF	-	CLCP	SWCP	PDCCP	-	

7	DBOUT	Debug output	0: Disable 1: Enable (P67 for PMD1, P77 for PMD2)	R/W
5	TMOF	Mode timer overflow	0: No overflow 1: Overflowed	R
3	CLCP	Capture mode timer by over- load protection	0: Disable 1: Enable	R/W
2	SWCP	Capture mode timer in software	0: No operation 1: Capture	W
1	PDCCP	Capture mode timer by position detection	0: Disable 1: Enable	R/W

Note: Read-modify-write instructions, such as a bit manipulation instruction, cannot access the MTCRB because it contains a write-only bit.

MTCRA (01FA4H) (01FD4H)	7	6	5	4	3	2	1	0	(Initial value: 0000 0000)
	TMCK		RBTM3	RBCL	SWRES	RBPDC	TMEN		

7, 6, 5	TMCK	Select clock	000: $fc/2^3$ (400 ns at 20 MHz) 010: $fc/2^4$ (800 ns at 20 MHz) 100: $fc/2^5$ (1.6 $\mu$ s at 20 MHz) 110: $fc/2^6$ (3.2 $\mu$ s at 20 MHz) 001: $fc/2^7$ (6.4 $\mu$ s at 20 MHz) 011: Reserved 101: Reserved 111: Reserved	R/W
4	RBTM3	Reset mode timer from Timer 3	0: Disable 1: Enable	R/W
3	RBCL	Reset mode timer by overload protection	0: Disable 1: Enable	
2	SWRES	Reset mode timer in software	0: No operation 1: Reset	W
1	RBPDC	Reset mode timer by position detection	0: Disable 1: Enable	R/W
0	TMEN	Enable/disable mode timer	0: Disable 1: Enable timer start	

Note 1: When changing MTCRA<TMCK> setting, keep the MTCRA<TMEN> bit reset to "0" (disable mode timer).

Note 2: Read-modify-write instructions, such as a bit manipulation instruction, cannot access the MTCRA because it contains a write-only bit.

MCAP (01FA7H, 01FA6H) (01FD7H, 01FD6H)	F	E	D	C	B	A	9	8	7	6	5	4	3	2	1	0	(Initial value: 0000 0000 0000 0000)
	DF	DE	DD	DC	DB	DA	D9	D8	D7	D6	D5	D4	D3	D2	D1	D0	

MCAP	Mode capture	Position detection interval	R
------	--------------	-----------------------------	---

CMP1 (01FA9H, 01FA8H) (01FD9H, 01FD8H)	F	E	D	C	B	A	9	8	7	6	5	4	3	2	1	0	(Initial value: 0000 0000 0000 0000)
	DF	DE	DD	DC	DB	DA	D9	D8	D7	D6	D5	D4	D3	D2	D1	D0	

CMP2 (01FABH, 01FAAH) (01FDBH, 01FDAH)	F	E	D	C	B	A	9	8	7	6	5	4	3	2	1	0	(Initial value: 0000 0000 0000 0000)
	DF	DE	DD	DC	DB	DA	D9	D8	D7	D6	D5	D4	D3	D2	D1	D0	

CMP3	F	E	D	C	B	A	9	8	7	6	5	4	3	2	1	0	(Initial value: 0000 0000 0000 0000)
(01FADH, 01FACH) (01FDDH, 01FDCH)	DF	DE	DD	DC	DB	DA	D9	D8	D7	D6	D5	D4	D3	D2	D1	D0	

CMP1	Timer 1	Magnitude comparison compare register	R/W
CMP2	Timer 2	Matching comparison compare register	
CMP3	Timer 3	Matching comparison compare register	

Note: Read-modify-write instructions, such as a bit manipulation instruction, cannot access the MTCRB or MTCRA register because these registers contain write-only bits.

### 13.4.1.2 Outline Processing in the Timer Unit

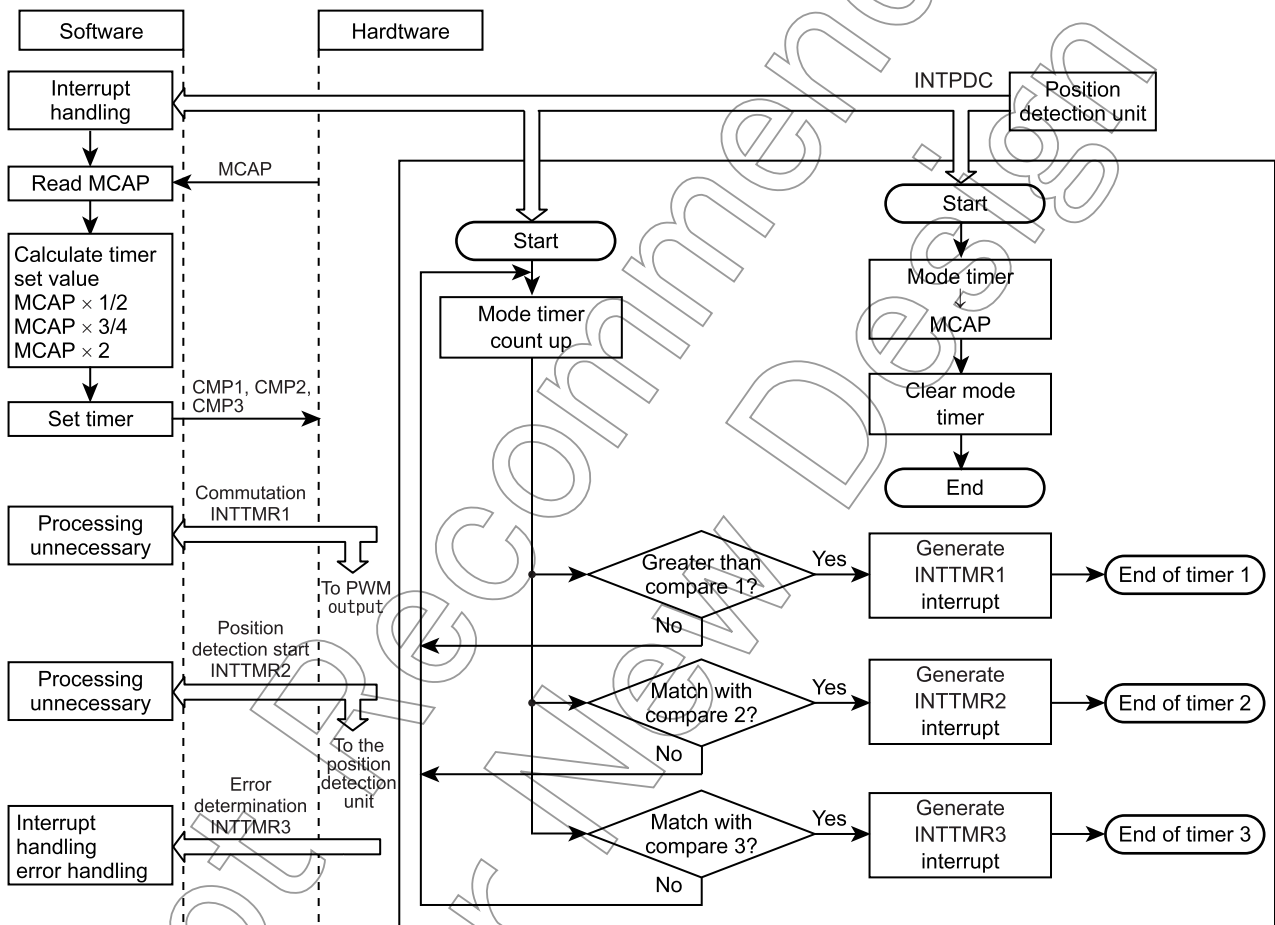

## 13.5 Three-phase PWM Output Unit

The Three-phase PWM Output Unit has the function to generate three-phase PWM waves with any desired pulse width and the commutation function capable of brushless DC motor control. In addition, it has the protective functions such as overload protection and emergency stop functions necessary to protect the power drive unit, and the dead time adding function which helps to prevent the in-phase upper/lower transistors from getting shorted by simultaneous turn-on when switched over.

For the PWM output pin (U,V,W,X,Y,Z), set the port register PxDR and PxCR (x = 3,5) to 1. The PWM output initially is set to be active low, so that if the output needs to be used active high, set up the MDCRA Register accordingly.

### 13.5.1 Configuration of the three-phase PWM output unit

The three-phase PWM output unit consists of a pulse width modulation circuit, commutation control circuit, protective circuit (emergency stop and overload), and a dead time control circuit.

#### 13.5.1.1 Pulse width modulation circuit (PWM waveform generating unit)

This circuit produces three-phase independent PWM waveforms with an equal PWM frequency. For PWM waveform mode, triangular wave modulation or sawtooth wave modulation can be selected by using the PMD Control Register (MDCRA) bit 1. The PWM frequency is set by using the PMD Period Register (MDPRD). The following shows the relationship between the value of this register and the PWM counter clock set by the MDCRB Register, PWMCK.

$$\text{Sawtooth wave PWM: MDPRD Register set value} = \frac{1}{\text{PWM frequency [Hz]} \times \text{PWMCK}}$$

$$\text{Triangular wave PWM: MDPRD Register set value} = \frac{1}{\text{PWM frequency [Hz]} \times 2 \times \text{PWMCK}}$$

The PMD Period Register (MDPRD) is comprised of dual-buffers, so that CMPU, V, W Register is updated with PWM period.

When the waveform arithmetic circuit is operating, the PWM waveform output unit receives calculation results from the waveform arithmetic circuit and by using the results as CMPU, V, W Register set value, it outputs independent three-phase PWM waveforms. When the waveform calculation function is enabled by the waveform arithmetic circuit and transfer of calculation results into the CMPU to W Registers is enabled (with EDCRA Register bit 2), the CMPU to W Registers are disabled against writing.

When the waveform calculation function is enabled (with EDCRA Register bit 1) and transfer of calculation results into the CMPU, V, W Registers is disabled (with EDCRA Register bit 4), the calculation results are transferred to the buffers of CMPU, V, W Registers, but not output to the port.

Read-accessing the CMPU, V, and W registers can read the calculation results of the waveform arithmetic circuit that have been input to a buffer. After changing the read calculation result data by software, writing the changed data to the CMPU, V, and W registers enables an arbitrary waveform other than a sinusoidal wave to be output. When the registers are read after writing, the values written to the registers are read out if accessed before the calculation results are transferred after calculation is finished.

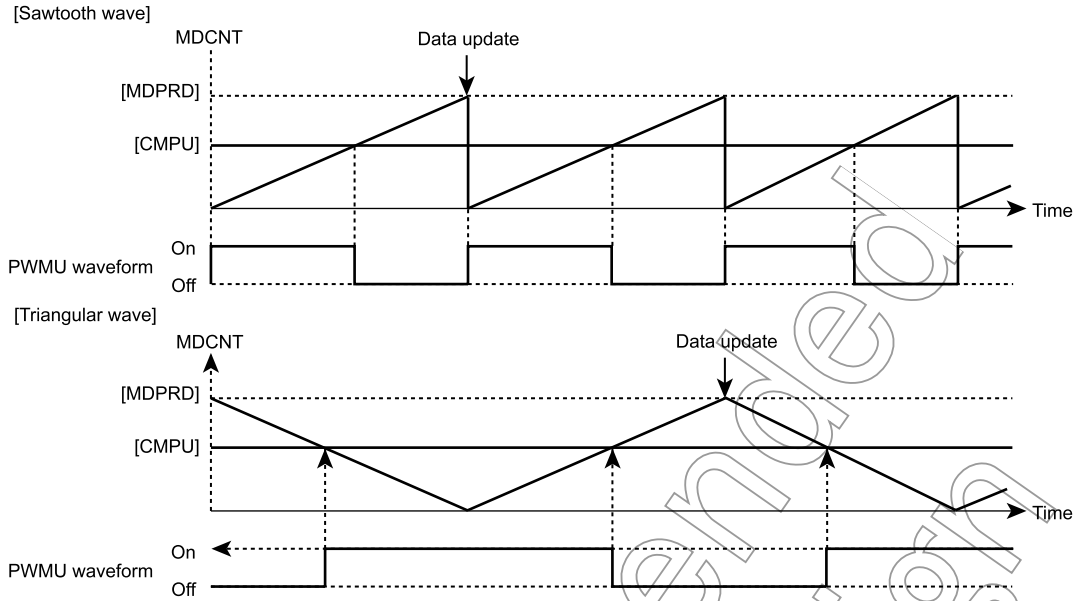

Figure 13-9 PWM Waveforms

The values of the PWM Compare Registers (CMPU/V/W) and the carrier wave generated by the PWM Counter (MDCNT) are compared for the relative magnitude by the comparator to produce PWM waveforms.

The PWM Counter is a 12-bit up/down counter with a 100 ns (at  $f_c = 20$  MHz) resolution.

For three-phase output control, two methods of generating three-phase PWM waveforms can be set.

1. Three-phase independent mode: Values are set independently in the three-phase PMD Compare Registers to produce three-phase independent PWM waveforms. This method may be used to produce sinusoidal or any other desired drive waveforms.
2. Three-phase common mode: A value is set in only the U-phase PMD Compare Register to produce three in-phase PWM waveforms using the U phase set value. This method may be used for DC motor square wave drive.

The three-phase PMD Compare Registers each have a comparison register to comprise a dual-buffer structure. The values of the PMD Compare Registers are loaded into their respective comparison registers synchronously with PWM period.



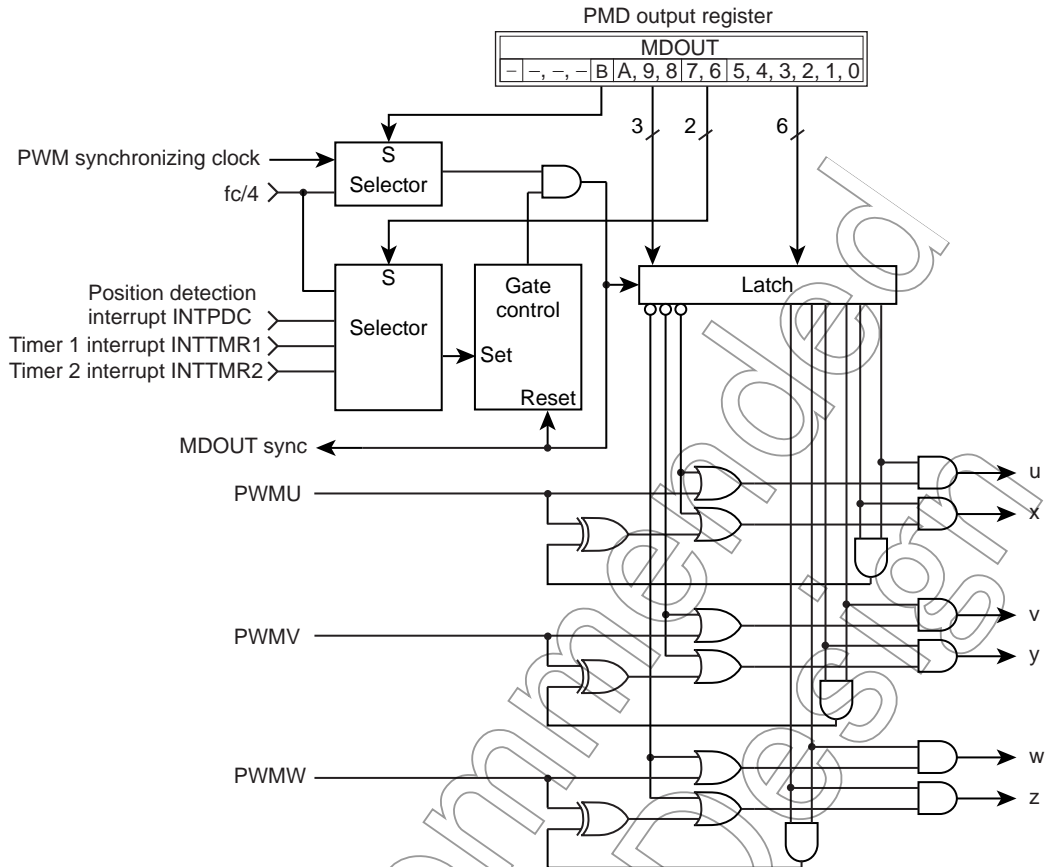

Figure 13-11 Commutation Control Circuit

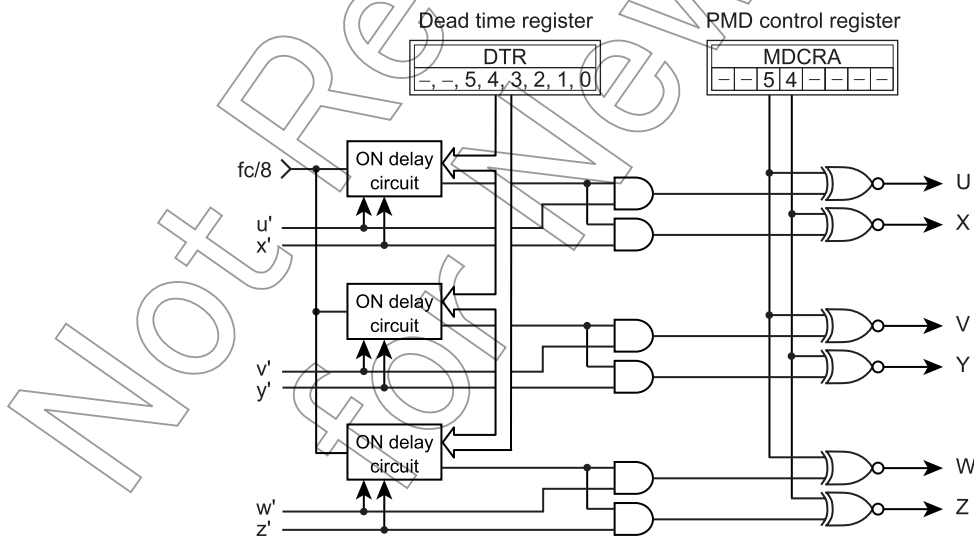

Figure 13-12 Dead Time Circuit



### 13.5.2 Register Functions of the Waveform Synthesis Circuit

MDCRB

PWMCK	Select PWM counter clock	Select PWM counter clock.
-------	--------------------------	---------------------------

MDCRA

7	HLFINT	Select half-period interrupt	When this bit is set to 1, INTPWM is generated every half period (at triangular wave peak and valley) in the case of center PWM output and PINT = 00. In other cases, this setting has no meaning.
6	DTYMD	DUTY mode	Select whether to set the duty cycle independently for three phases using the CMPU to W Registers or in common for all three phases by setting the CMPU Register only.
5	POLH	Upper-phase port polarity	Select the upper-phase output port polarity. Make sure the waveform synthesis function (MDCRA Register bit 0) is idle before selecting this port polarity.
4	POLL	Lower-phase port polarity	Select the lower-phase output port polarity. Make sure the waveform synthesis function (MDCRA Register bit 0) is idle before selecting this port polarity.
3, 2	PINT	PWM interrupt frequency	Select the frequency at which to generate a PWM interrupt from four choices available: every PWM period or once every 2, 4, or 8 PWM periods. When setting of this bit is altered while operating, an interrupt may be generated at the time the bit is altered.
1	PWMMD	PWM mode	Select PWM mode. PWM mode 0 is an edge PWM (sawtooth wave), and PWM mode 1 is a center PWM (triangular wave).
0	PWMEN	Enable/Disable waveform generation circuit	When enabling this circuit (for waveform output), be sure to set the output port polarity and other bits of this register (other than MDCRA bit 0) beforehand.

DTR

DTR	Dead time	Set the dead time between the upper-phase and lower-phase outputs.
-----	-----------	--

MDOUT

F	UPDOWN	PWM counter flag	This bit indicates whether the PWM counter is counting up or down. When edge PWM (sawtooth wave) is selected, it is always set to 0.
E, D, C	PDEXP	Mode compare register	Set the data to be compared with the position detection input port. The comparison data is adopted as the expected value simultaneously when port output sync settings made with MDOUT are reflected in the ports. (This is the expected position detection input value for the output set with MDOUT next time.)
B	PSYNC	Select PWM synchronization	Select whether or not to synchronize port output to PWM period after being synchronized to the synchronizing signal selected with SYNCS. If selected to be synchronized to PWM, output is kept waiting for the next PWM after being synchronized with SYNCS. Waveform settings are overwritten if new settings are written to the register during this time, and output is generated with those settings.
A 9 8	WPWM VPWM UPWM	Control UVW-phase PWM outputs	Set U, V, and W-phase port outputs. (See the Table 13-3)
7, 6	SYNCS	Select port output sync signal	Select the synchronizing signal with which to output UVW-phase settings to ports. The synchronizing signal can be selected from Timers 1 or 2, position detection, or asynchronous. Select asynchronous when the initial setting, otherwise the above setting isn't reflected immediately.
5, 4 3, 2 1, 0	WOC VOC UOC	Control UVW-phase outputs	Set U, V, and W-phase port outputs. (See the Table 13-3)

MDCNT	PWM counter	This is a 12-bit read-only register used to count PWM periods.
-------	-------------	--

M DPRD	Set PWM period	This register determines PWM period, and is dual-buffered, allowing PWM period to be altered even while the PWM counter is operating. The buffers are loaded every PWM period. When 100 ns is selected for the PWM counter clock, make sure the least significant bit is set to 0.
--------	----------------	--

CMPU CMPV CMPW	Set PWM pulse width	This comparison register determines the pulse widths output in the respective UVW phases. This register is dual-buffered, and the pulse widths are determined by comparing the buffer and PWM counter.
----------------------	---------------------	--

Waveform Synthesis Circuit Registers [Addresses (PMD1 and PMD2)]

MDCRB (01FAFH) (01FDFH)	7	6	5	4	3	2	1	0	(Initial value: **** *00)
	-	-	-	-	-	-	PWMCK		

1, 0	PWMCK	PWM counterSelect clock	00: $f_c/2$ [Hz] (100 ns at 20 MHz) 01: $f_c/2^2$ (200 ns at 20 MHz) 10: $f_c/2^3$ (400 ns at 20 MHz) 11: $f_c/2^4$ (800 ns at 20 MHz)	R/W
------	-------	-------------------------	---	-----

Note: When changing setting, keep the PWMEN bit reset to "0" (disable wave form synthesis function).

MDCRA (01FAEH) (01FDEH)	7	6	5	4	3	2	1	0	(Initial value: 0000 0000)
	HLFINT	DTYMD	POLH	POLL	PINT	PWMMD	PWMEN		

7	HLFINT	Select half-period interrupt	0: Interrupt as specified in PINT 1: Interrupt every half period when PINT = 00	R/W
6	DTYMD	DUTY mode	0: U phase in common 1: Three phases independent	
5	POLH	Upper-phase port polarity	0: Active low 1: Active high	
4	POLL	Lower-phase port polarity	0: Active low 1: Active high	
3, 2	PINT	Select PWM interrupt (trigger)	00: Interrupt every period 01: Interrupt once every 2 periods 10: Interrupt once every 4 periods 11: Interrupt once every 8 periods	
1	PWMMD	PWM mode	0: PWM mode0 (Edge: Sawtooth wave) 1: PWM mode1 (Center: Triangular wave)	
0	PWMEN	Enable/disable waveform synthesis function	0: Disable 1: Enable (Waveform output)	

DTR (01FBEH) (01FEEH)	7	6	5	4	3	2	1	0	(Initial value: **00 0000)
	-	-	D5	D4	D3	D2	D1	D0	

5 to 0	DTR	Dead time	$2^3/f_c \times 6$ bit (maximum 25.2 $\mu$ s at 20 MHz)	R/W
--------	-----	-----------	---	-----

Note: When changing setting, keep the MDCRA<PWMEN> bit reset to "0" (disable wave form synthesis function).

MDOUT (01FB3H, 01FB2H)	F	E	D	C	B	A	9	8	
(01FE3H, 01FE2H)	UPDWN	PDEXP		PSYNC	WPWM	VPWM	UPWM		
	7	6	5	4	3	2	1	0	
	SYNCS		WOC		VOC		UOC		(Initial value: 00000000 00000000)

F	UPDWN	PWM counter flag	0: Counting up 1: Counting down	R/W
E, D, C	PDEXP	Comparison register for position detection	bit E: W-phase expected value bit D: V-phase expected value bit C: U-phase expected value	
B	PSYNC	Select PWM synchronization	0: Asynchronous 1: Synchronized	
A	WPWM	W-phase PWM output	0: H/L level output 1: PWM waveform output	
9	VPWM	V-phase PWM output	0: H/L level output 1: PWM waveform output	
8	UPWM	U-phase PWM output	0: H/L level output 1: PWM waveform output	
7, 6	SYNCS	Select port output synchronizing signal	00: Asynchronous 01: Synchronized to position detection 10: Synchronized to Timer 1 11: Synchronized to Timer 2	
5, 4	WOC	Control W-phase output	See the table 1-3	
3, 2	VOC	Control V-phase output		
1, 0	UOC	Control U-phase output		

13.5.3 Port output as set with UOC/VOC/WOC bits and UPWM/VPWM/WPWM bits

Table 13-3 Example of Pin Output Settings

U-phase output polarity: Active high  
(POLH,POLL = 1)

U-phase output polarity: Active low  
(POLH,POLL = 0)

UOC	UPWM			
	1: PWM output		0: H/L level output	
	U phase	X phase	U phase	X phase
0 0	PWM	PWM	L	L
0 1	L	PWM	L	H
1 0	PWM	L	H	L
1 1	PWM	$\overline{\text{PWM}}$	H	H

UOC	UPWM			
	1: PWM output		0: H/L level output	
	U phase	X phase	U phase	X phase
0 0	PWM	PWM	H	H
0 1	H	$\overline{\text{PWM}}$	H	L
1 0	$\overline{\text{PWM}}$	H	L	H
1 1	$\overline{\text{PWM}}$	PWM	L	L

MDCNT (01FB5H, 01FB4H) (01FE5H, 01FE4H)	F	E	D	C	B	A	9	8	7	6	5	4	3	2	1	0	(Initial value: ****000000000000)
	-	-	-	-	DB	DA	D9	D8	D7	D6	D5	D4	D3	D2	D1	D0	

B to 0	PWM counter	PWM period counter value	R
--------	-------------	--------------------------	---

MDPRD (01FB7H, 01FB6H) (01FE7H, 01FE6H)	F	E	D	C	B	A	9	8	7	6	5	4	3	2	1	0	(Initial value: ****000000000000)
	-	-	-	-	DB	DA	D9	D8	D7	D6	D5	D4	D3	D2	D1	D0	

B to 0	PWM period	PWM period MDPRD ≥ 010H	R/W
--------	------------	-------------------------	-----

CMPU (01FB9H, 01FB8H) (01FE9H, 01FE8H)	F	E	D	C	B	A	9	8	7	6	5	4	3	2	1	0	(Initial value: ****000000000000)
	-	-	-	-	DB	DA	D9	D8	D7	D6	D5	D4	D3	D2	D1	D0	

CMPV (01FBBH, 01FBAH) (01FEBH, 01FEAH)	F	E	D	C	B	A	9	8	7	6	5	4	3	2	1	0	(Initial value: ****000000000000)
	-	-	-	-	DB	DA	D9	D8	D7	D6	D5	D4	D3	D2	D1	D0	

CMPW (01FBDH, 01FBCH) (01FEDH, 01FECH)	F	E	D	C	B	A	9	8	7	6	5	4	3	2	1	0	(Initial value: ****000000000000)
	-	-	-	-	DB	DA	D9	D8	D7	D6	D5	D4	D3	D2	D1	D0	

B to 0	CMPU	PWM compare U register	Set U-phase duty cycle	R/W
	CMPV	PWM compare V register	Set V-phase duty cycle	
	CMPW	PWM compare W register	Set W-phase duty cycle	

Not Recommended for New Designs

### 13.5.4 Protective Circuit

This circuit consists of an EMG protective circuit and overload protective circuit. These circuits are activated by driving their respective port inputs active.

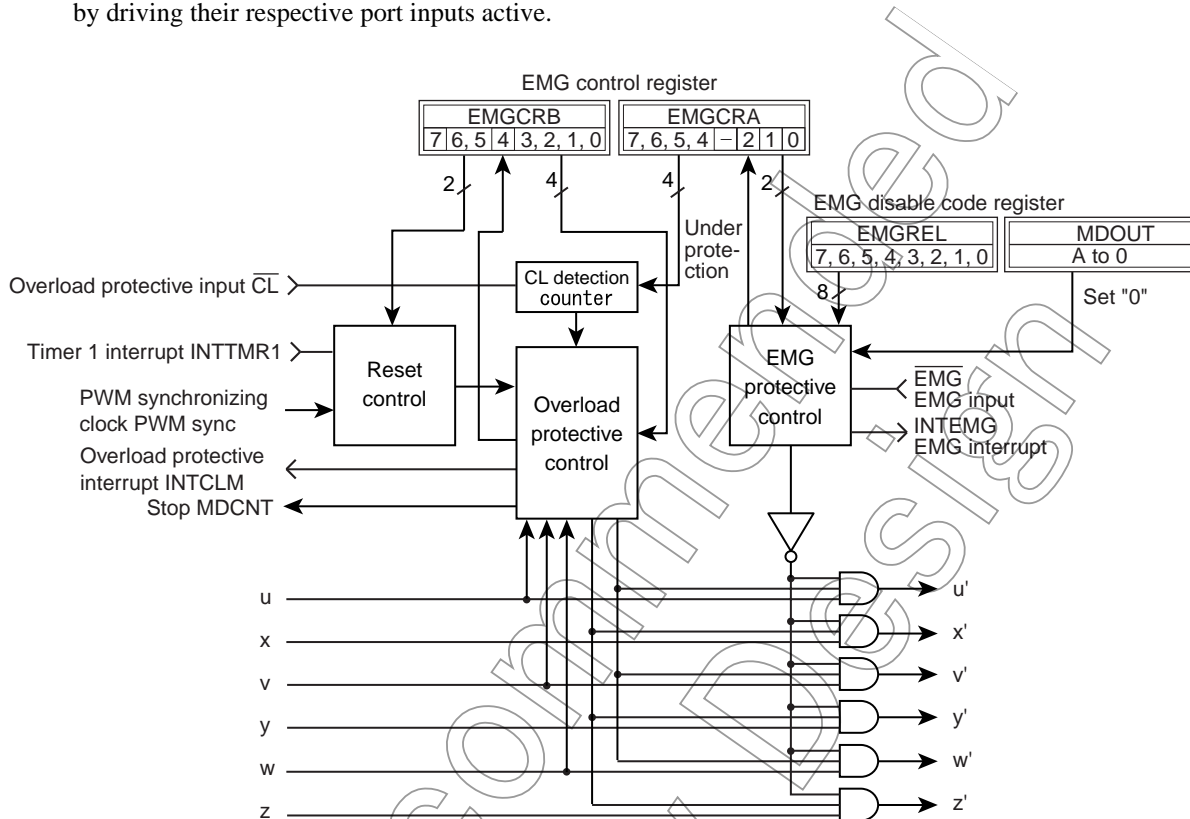

Figure 13-13 Configuration of the Protective Circuit

a. EMG protective circuit

This protective circuit is used for emergency stop, when the EMG protective circuit is enabled. When the signal on EMG input port goes active (negative edge triggered), the six ports are immediately disabled high-impedance against output and an EMG interrupt (INTEMG) is generated. The EMG Control Register (EMGCRA) is used to set EMG protection. If the EMGCRA<EMGST> shows the value “1” when read, it means that the EMG protective circuit is operating. To return from the EMG protective state, reset the MDOUT Register bits A to 0 and set the EMGCRA<RTE> to 1. Returning from the EMG protective state is effective when the EMG protective input has been released back high. To disable the EMG function, set data “5AH” and “A5H” sequentially in the EMG disable Register (EMGREL) and reset the EMGCRA<EMGEN> to 0. When the EMG function is disabled, EMG interrupts (INTEMG) are not generated.

The EMG protective circuit is initially enabled. Before disabling it, fully study on adequacy.

b. Overload protective circuit

The overload protective circuit is set by using the EMG Control Registers (EMGCRB/A). To activate overload protection, set the EMGCRB<CLEN> to 1 to enable the overload protective circuit. The circuit starts operating when the overload protective input is pulled low.

To return from overload state, there are three methods to use: return by a timer (EMGCRB<RTTM1>), return by PWM sync (EMGCRB<RTPWM>), or return manually (EMGCRB<RTCL>). These methods are usable when the overload protective input has been released back high.

The number of times the overload protective input is sampled can be set by using the EMGCRA<CLCNT>. The sampling times can be set in the range of 1 to 15 times at 200 ns period (when  $f_c = 20$  MHz). If a low level is detected as many times as the specified number, overload protection is assumed.

The output disabled phases during overload protection are set by using the EMGCRB<CLMD>. This facility allows selecting to disable no phases, all phases, PWM phases, or all upper phases/all lower phases. When selected to disable all upper phases/all lower phases, port output is determined by their turn-on status immediately before being disabled. When two or more upper phases are active, all upper phases are turned on and all lower phases are turned off; when two or more lower phases are active, all upper phases are turned off and all lower phases are turned on.

When output phase are cut off, output is inactive (low in the case of high active). When the overload protective circuit is disabled, overload protective interrupts (INTCLM) are not generated.

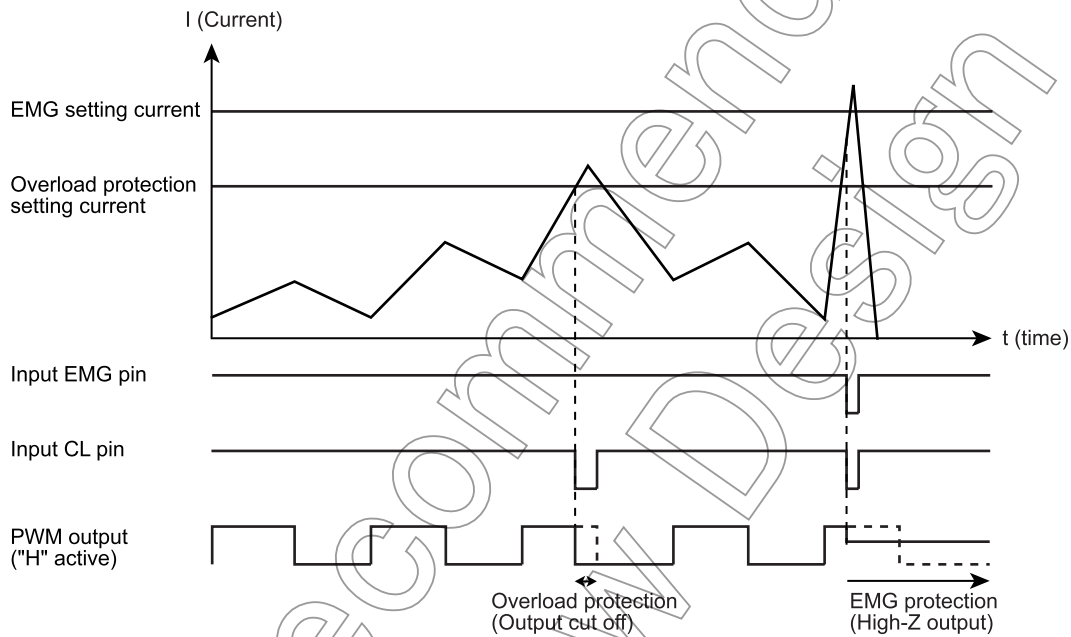

Figure 13-14 Example of Protection Circuit Operation

Not Recommended for New Design

## 13.5.5 Functions of Protective Circuit Registers

EMGREL	EMG disable	The EMG protective circuit is disabled from the disabled state by writing "5AH" and "A5H" to this register in that order. After that, the EMGCRA Register needs to be set.
--------	-------------	--

## EMGCRB

7	RTCL	Return from overload protective state	When this bit is set to 1, the motor control circuit is returned from overload protective state in software (e.g., by writing to this register). Also, the current state can be known by reading this bit. MDOUT outputs at return from the overload protective state remain as set before the overload protective input was driven active.
6	RTPWM	Return by PWM sync	When this bit is set to 1, the motor control circuit is returned from overload protective state by PWM sync. If RTCL is set to 1, RTCL has priority.
5	RTTM1	Return by timer sync	When this bit is set to 1, the motor control circuit is returned from overload protective state by Timer 1 sync. If RTCL is set to 1, RTCL has priority.
4	CLST	Overload protective state	The status of overload protection can be known by reading this bit.
3, 2	CLMD	Select output disabled phases during overload protection	Select the phases to be disabled against output during overload protection. This facility allows selecting to disable no phases, all phases, PWM phases, or all upper phases/all lower phases.
1	CNTST	Stop counter during overload protection	Can stop the PWM counter during overload protection.
0	CLEN	Enable/Disable overload protection	Enable or disable the overload protective function.

## EMGCRA

7 to 4	CLCNT	Overload protection sampling time	Set the length of time the overload protective input port is sampled.
2	EMGST	EMG protective state	The status of EMG protection can be known by reading this bit.
1	RTE	Return from EMG protective state	The motor control circuit is returned from EMG protective state by setting this bit to "1". When returning, set the MDOUT Register A to 0 bits to "0". Then set the EMGCRA Register bit 1 to "1" and set MDOUT waveform output. Then set up the MDCRA Register.
0	EMGEN	Enable/Disable EMG protective circuit	The EMG protective circuit is activated by setting this bit to 1. This circuit initially is enabled. (To disable this circuit, make sure key code 5AH and A5H are written to the EMGREL1 Register beforehand.)

## Protective Circuit Registers [Addresses (PMD1 and PMD2)]

EMGREL (01FBFH) (01FEFH)	7	6	5	4	3	2	1	0	(Initial value: 0000 0000)
	D7	D6	D5	D4	D3	D2	D1	D0	

7 to 0	EMGREL	EMG disable	Can disable by writing 5AH and then A5H.	W
--------	--------	-------------	--	---

Note: Read-modify-write instructions, such as a bit manipulation instruction, cannot access the EMGREL register because this register is write only.

EMGCRB (01FB1H) (01FE1H)	7	6	5	4	3	2	1	0	(Initial value: 0000 0000)
	RTCL	RTPWM	RTTM1	CLST	CLMD	CNTST	CLEN		

7	RTCL	Return from overload protective state	0: No operation 1: Return from protective state	W
6	RTPWM	Enable/Disable return from overload protective state by PWM sync	0: Disable 1: Enable	R/W
5	RTTM1	Enable/Disable return from overload protective state by timer 1	0: Disable 1: Enable	
4	CLST	Overload protective state	0: No operation 1: Under protection	R
3, 2	CLMD	Select output disabled phases during overload protection	00: No phases disabled against output 01: All phases disabled against output 10: PWM phases disabled against output 11: All upper/All lower phases disabled against output (Note)	R/W
1	CNTST	Stop PWM counter during overload protection	0: Do not stop 1: Stop the counter	
0	CLEN	Enable/Disable overload protective circuit	0: Disable 1: Enable	

Note: If during overload protection the port output state in two or more upper phases is on, all lower phases are disabled and all upper phases are enabled for output; when two or more lower phases are on, all upper phases are disabled and all lower phases are enabled for output.

EMGCRA (01FB0H) (01FE0H)	7	6	5	4	3	2	1	0	(Initial value: 0000 *001)
	CLCNT					EMGST	RTE	EMGEN	

7 to 4	CLCNT	Overload protection sampling number of times.	$2^2/f_c \times n$ (n = 1 to 15, 0 and 1 are set as 1 at 20 MHz)	R/W
2	EMGST	EMG protective state	0: No operation 1: Under protection	R
1	RTE	Return from EMG state	0: No operation 1: Return from protective state (Note 1)	W
0	EMGEN	Enable/Disable EMG protective circuit	0: Disable 1: Enable	R/W

Note 1: An instruction specifying a return from the EMG state is invalid if the  $\overline{\text{EMG}}$  input is "L".

Note 2: Read-modify-write instructions, such as a bit manipulation instruction, cannot access the EMGCRB or EMGCRA register because these registers contain write-only bits.



### 13.6 Electrical Angle Timer and Waveform Arithmetic Circuit

#### Electrical Angle Timer

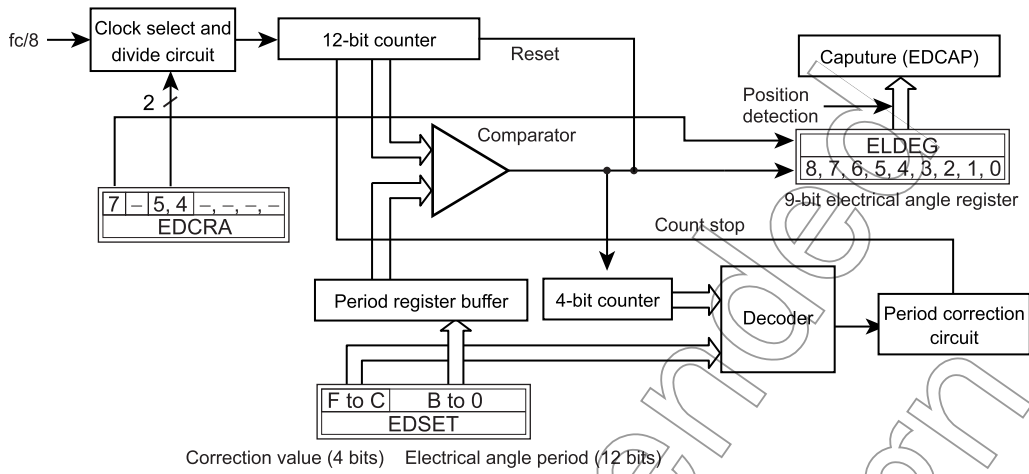

Figure 13-15 Electrical Angle Timer Circuit

#### Waveform Arithmetic Circuit

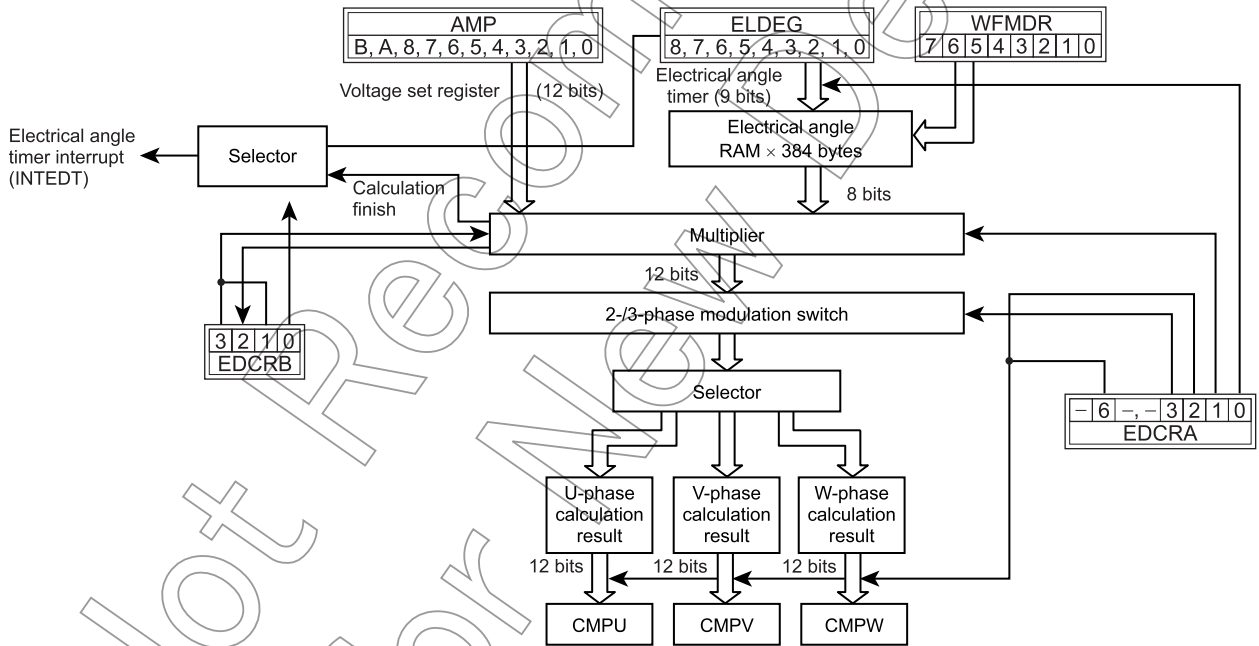

Figure 13-16 Waveform Arithmetic Circuit

### 13.6.1 Electrical Angle Timer and Waveform Arithmetic Circuit

The Electrical Angle Timer finishes counting upon reaching the value set by the Period Set Register (EDSET). The Electrical Angle Timer counts 360 degrees of electrical angle in the range of 0 to 383 (17FH) and is cleared to 0 upon reaching 383. In this way, it is possible to obtain the electrical angle of the frequency proportional to the value set by the Period Set Register. The period with which to count up can be corrected by using the Period Correction Register, allowing for fine adjustment of the frequency. The electrical angles counted by the Electrical Angle Timer are presented to the Waveform Arithmetic Circuit. An electrical angle timer interrupt signal is generated each time the Electrical Angle Timer finishes counting.

The Waveform Arithmetic Circuit has a sine wave data table, which is used to extract sine wave data based on the electrical angle data received from the Electrical Angle Timer. This sine wave data is multiplied by the value of the Voltage Amplitude Register. For 2-phase modulation, the product obtained by this multiplication is presented to the waveform synthesis circuit. For 3-phase modulation, waveform data is further calculated based on the product of multiplication and the electrical angle data and the value of the PWM Period Register. The calculation is performed each time the Electrical Angle Timer finishes counting or when a value is set in the Electrical Angle Register, and the calculation results consisting of the U phase, the V phase (+120 degrees), and the W phase (+240 degrees) are sequentially presented to the PWM waveform output circuit. The sine wave data table is stored in the RAM and requires initialization.

- To correct the period, set the number of times 'n' to be corrected in the Period Correction Register (EDSET Register F to C bits). The period is corrected by adding 1 to electrical angle counts 16 for 'n' times. For example, when a value 3 is set in the Period Correction Register, the period for 13 times out of electrical angle counts 16 is the value "mH" set in the Period Set Register, and that for 3 times is "m + 1H". (Correction is made almost at equal intervals.)
- Because the electrical angle counter (ELDEG) can be accessed even while the Electrical Angle Timer is operating, the electrical angles can be corrected during operation.
- The Electrical Angle Capture EDCAP captures the electrical angle value from the Electrical Angle Counter at the time the position is detected.
- When the waveform calculation function is enabled, waveform calculation is performed each time the electrical angle counter (ELDEG) are accessed for write or the Electrical Angle Timer finishes counting.
- The calculation is performed in 35 machine cycle of execution time, or 7  $\mu$ s (at 20 MHz).
- When transfer of calculation result to the CMP Registers is enabled (EDCRA<RWREN>), the calculation results are transferred to the CMPU to W Registers. (This applies only when the waveform calculation function is enabled with the EDCRA<CALCEN>.) The CMPU to W Registers are disabled against write while the transfer remains enabled. The calculation results can be read from the CMPU to W Registers while the waveform calculation function remains enabled.
- The calculated results can be modified and the modified data can be set in the CMPU to W Registers in software. This makes it possible to output any desired waveform other than sine waves. If a transfer (EDCRA register bit 2) of the calculated results to the CMP register is disabled, read-accessing the CMPU to W registers can read the calculated results. (Before read-accessing these registers, make sure that the calculation is completed.)
- To initialize the entire RAM data of the sine wave data table, set the addresses at which to set, sequentially from 000H to 17FH, in the ELDEG Register, and write waveform data to the WFMDR Register each time. Make sure the Waveform Arithmetic Circuit is disabled when writing this data.

Note 1: The value set in the Period Set Register (EDSET Register EDT bits) must be equal to or greater than 010H. Any value smaller than this is assumed to be 010H.

Note 2: The sine wave data that is read consists of the U phase, the V phase whose electrical angle is +120 degrees relative to the U phase, and the W phase whose electrical angle is +240 degrees relative to the U phase.

Note 3: If a period corresponding to an electrical angle of one degree is shorter than the required calculation time, the previously calculated results are used.

13.6.1.1 Functions of the Electrical Angle Timer and Waveform Arithmetic Circuit Registers

EDCRB

3	CALCST	Start calculation by software	Forcefully start calculation. When this bit is written while the waveform arithmetic circuit is calculating, the calculation is terminated and then newly started.
2	CALCBSY	Calculation flag	By reading this bit, the operation status of the waveform arithmetic circuit can be obtained.
1	EDCALEN	Enable/disable calculation start synchronized with electrical angle	Select whether to start calculation when the electrical angle timer finishes counting or when a value is set in the electrical angle register. When disabled, calculation is only started when CALCST is set to 1.
0	EDISEL	Electrical angle interrupt	Set the electrical angle interrupt signal request timing to either when the electrical angle timer finishes counting or upon end of calculation.

EDCRA

7	EDCNT	Electrical angle count up/down	Set whether the electrical angle timer counts up or down.
6	EDRV	Select V-, W-phase	Select phase direction of V-phase and W-phase in relation to U-phase.
5, 4	EDCK	Select clock	Select the clock for the electrical angle timer. This setting can be altered even while the electrical angle timer is operating.
3	C2PEN	Switch between 2-phase and 3-phase modulations	Select the modulation method with which to perform waveform calculation. Two-phase modulation $DATA = ramdata(ELDEG) \times AMP$ Three-phase modulation: $DATA = \frac{MOPRD \pm ramdata(ELDEG) \times AMP}{2}$ Note: The $\pm$ sign during 3-phase modulation changes depending on the electrical angle. + for electrical angles 0 to 179 degrees (191) - for electrical angles 180 (192) to 360 (383) degrees
2	RWREN	Auto transfer calculation results to CPM registers	Enable/disable transfer of calculation results by the waveform arithmetic circuit. When the waveform calculation function is enabled while at the same time transfer is enabled, calculation results are set as U, V, and W-phase duty cycles of the PWM generation circuit and are reflected in the ports.
1	CALCEN	Enable/disable waveform calculation function	Enable/disable the waveform calculation function. Calculations are performed by the waveform arithmetic circuit by enabling the waveform calculation function. When the waveform calculation function is enabled, the calculated results can be read from the U, V, and W-phase compare registers (CMPU, V, W) of the PWM generation circuit.
0	EDTEN	Electrical angle timer	Enable/disable the electrical angle timer. When enabled, the electrical angle timer starts counting; when disabled, the electrical angle timer stops counting and is cleared to 0.

EDSET

F to C	EDTH	Correct electrical angle period	Correct the period by adding 1 to electrical angle counts 16 for "n" times. The timer counts the electrical angle period set value "m" for (16 - n) times and counts (m + 1) for "n" times
B to 0	EDT	Electrical angle period	Set the electrical angle period.

ELDEG	Electrical angle	Read the electrical angle. This register can also be set to initialize or correct the angle while counting. Any value greater than 17FH cannot be set.
-------	------------------	--

AMP	Set voltage amplitude	Set the voltage amplitude. The waveform arithmetic circuit multiplies the data set here by the sine wave data read out from the sine wave RAM. The amplitude has its upper limit determined by the set value of the MDP RD register when performing this multiplication.
-----	-----------------------	--

EDCAP	Capture electrical angle	Capture the value from the electrical angle timer when the position is detected.
-------	--------------------------	--

WFMDR	Set sine wave data	To initialize the entire RAM data of the sine wave table, set the addresses at which to set, sequentially from 000H to 17FH, in the ELDEG register, and write waveform data to the WFMDR register each time. Make sure the waveform arithmetic circuit is disabled when writing this data.
-------	--------------------	--

Typical Settings of Sine Wave Data

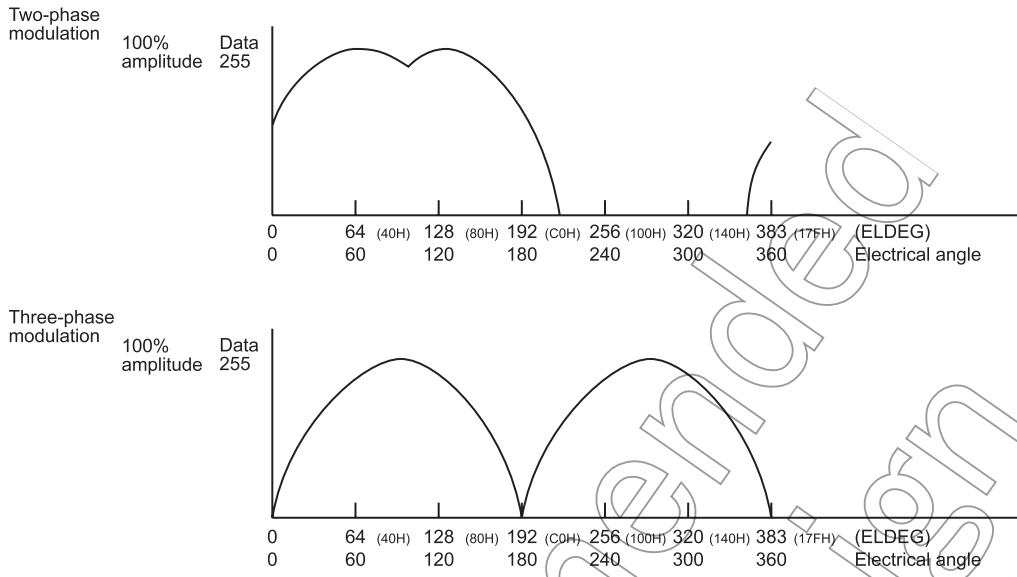

Note: During 3-phase modulation, the sign changes at 180 degrees of electrical angle.

Figure 13-17 Typical Settings of Sine Wave Data

Not Recommended for New Design

List of the Electrical Angle Timer and Waveform Arithmetic Circuit Registers [Addresses (PMD1 and PMD2)]

EDCRB (01FC1H) (01FF1H)	7	6	5	4	3	2	1	0	(Initial value: **** 0000)
	-	-	-	-	CALCST	CALCBSY	EDCALEN	EDISEL	

3	CALCST	Start calculation by software	0: No operation 1: Start calculation	W
2	CALCBSY	Calculation flag	0: Waveform Arithmetic Circuit stopped 1: Waveform Arithmetic Circuit calculating	R
1	EDCALEN	Enable/disable calculation start synchronized with electrical angle	0: Start calculation insync with electrical angle 1: Do not calculation insync with electrical angle	R/W
0	EDISEL	Electrical angle interrupt	0: Interrupt when the Electrical Angle Timer finishes counting 1: Interrupt upon end of calculation	

Note: Read-modify-write instructions, such as a bit manipulation instruction, cannot access the EDCRB register because this register is write only.

EDCRA (01FC0H) (01FF0H)	7	6	5	4	3	2	1	0	(Initial value: 0000 0000)
	EDCNT	EDRV	EDCK	C2PEN	RWREN	CALCEN	EDTEN		

7	EDCNT	Electrical angle count up/down	0: Count up 1: Count down	R/W
6	EDRV	Select V-, W-phase	0: $V = U + 120^\circ, W = U + 240^\circ$ 1: $V = U - 120^\circ, W = U - 240^\circ$	
5, 4	EDCK	Select clock	00: $fc/2^3$ (400 ns at 20 MHz) 01: $fc/2^4$ (800 ns at 20 MHz) 10: $fc/2^5$ (1.6 $\mu$ s at 20 MHz) 11: $fc/2^6$ (3.2 $\mu$ s at 20 MHz)	
3	C2PEN	Switch between 2-/3-phase modulations	0: 2-phase modulation 1: 3-phase modulation	
2	RWREN	Transfer calculation result to CMP registers	0: Disable 1: Enable	
1	CALCEN	Enable/disable waveform calculation function	0: Disable 1: Enable	
0	EDTEN	Electrical angle mode timer	0: Disable 1: Enable	

Note: When changing the EDCRA<EDCK> setting, keep the EDCRA<EDTEN> bit reset "0" (Disable electrical angle timer).

EDSET (01FC3H, 01FC2H) (01FF3H, 01FF2H)	F	E	D	C	B	A	9	8	7	6	5	4	3	2	1	0	(Initial value: 00000000 00010000)
	EDTH						EDT										

F to C	EDTH	Correct period (n)	0 to 15 times	R/W
B to 0	EDT	Set period (m)	≥ 010H	

One period of the Electrical Angle Timer, T, is expressed by the equation below.

$$T = \left( m + \frac{n}{16} \right) \times 384 \times \text{set clock}[s] \quad \text{where } m = \text{set period, } n = \text{period correction}$$

ELDEG (01FC5H, 01FC4H) (01FF5H, 01FF4H)	F	E	D	C	B	A	9	8	7	6	5	4	3	2	1	0	(Initial value: *****0 00000000)
	-	-	-	-	-	-	-	D8	D7	D6	D5	D4	D3	D2	D1	D0	

8 to 0	ELDEG	Electrical angle	Set the Initially and the count values of electrical angle.	R/W
--------	-------	------------------	---	-----

AMP (01FC7H, 01FC6H) (01FF7H, 01FF6H)	F	E	D	C	B	A	9	8	7	6	5	4	3	2	1	0	(Initial value: ****0000 00000000)
	-	-	-	-	DB	DA	D9	D8	D7	D6	D5	D4	D3	D2	D1	D0	

B to 0	AMP	Set voltage	Set the voltage to be used during waveform calculation.	R/W
--------	-----	-------------	---	-----

EDCAP (01FC9H, 01FC8H) (01FF9H, 01FF8H)	F	E	D	C	B	A	9	8	7	6	5	4	3	2	1	0	(Initial value: *****0 00000000)
	-	-	-	-	-	-	-	D8	D7	D6	D5	D4	D3	D2	D1	D0	

8 to 0	EDCAP	Captured value of electrical angle	Electrical angle timer value when position is detected.	R
--------	-------	------------------------------------	---	---

WFMDR (01FCAH) (01FFAH)	7	6	5	4	3	2	1	0	(Initial value: *****)
	D7	D6	D5	D4	D3	D2	D1	D0	

7 to 0	WFMDR	Sine wave data	Write sine wave data to RAM of sine wave	W
--------	-------	----------------	--	---

Note: Read-modify-write instructions, such as a bit manipulation instruction, cannot access the WFMDR register because this register is write only.

Not for

13.6.1.2 List of PMD Related Control Registers

(1) Input/output Pins and Input/output Control Registers

PMD1 Input/Output Pins (P3, P4) and Port Input/Output Control Registers (P3CR, P4CR)

Name	Address	Bit	R or W	Description
P3DR	00003H	7	R/W	Overload protection (CL1)
		6	R/W	EMG input (EMG1)
		5 to 0	R/W	U1/V1/W1/X1/Y1/Z1 outputs.
P4DR	00004H	2 to 0	R/W	Position signal inputs (PDU1, PDV1, PDW1).
P3CR	01F89H	7 to 0	R/W	P3 port input/output control (can be set bitwise). 0: Input mode 1: Output mode
P4CR	01F8AH	2, 1, 0	R/W	P0 port input/output control (can be set bitwise). 0: Input mode 1: Output mode

PMD2 Input/Output Pins (P5, P1) and Port Input/Output Control Registers (P5CR, P1CR)

Name	Address	Bit	R or W	Description
P5DR	00005H	0	R/W	Overload protection (CL2)
		1	R/W	EMG input (EMG2)
		2 to 7	R/W	U2/V2/W2/X2/Y2/Z2 outputs.
P1DR	00001H	5 to 7	R/W	Position signal inputs (PDU2, PDV2, PDW2).
P5CR	01F8BH	7 to 0	R/W	P3 port input/output control (can be set bitwise). 0: Input mode 1: Output mode
P1CR	0000BH	5, 6, 7	R/W	P0 port input/output control (can be set bitwise). 0: Input mode 1: Output mode

Note: When using these pins as PMD function or input port, set the Output Latch (P\*DR) to 1.

Example of the PMD Pin Port Setting

	Input/Output	P3DR	P3CR	P4DR	P4CR
CL1	Input	*	0	-	-
EMG1	Input	*	0	-	-
U1	Output	1	1	-	-
PDU1	Input	-	-	*	0

	Input/Output	P5DR	P5CR	P1DR	P1CR
CL2	Input	*	0	-	-
EMG2	Input	*	0	-	-
U2	Output	1	1	-	-
PDU2	Input	-	-	*	0

(2) Motor Control Circuit Control Registers  
 [Address Upper Stage: PMD1, Lower Stage: PMD2]

Position Detection Control Register (PDCR) and Sampling Delay Register (SDREG)

Name	Address	Bit	R or W	Description
PDCRC	01FA2H 01FD2H	5, 4	R	Detect the position-detected position. 00: Within the current pulse 01: When PWM is off 10: Within the current pulse 11: Within the preceding pulse
		3	R	Monitor the sampling status. 0: Sampling idle 1: Sampling in progress
		2 to 0	R	Holds the status of the position signal input during unmatch detection mode. Bits 2, 1, and 0: W, V, and U phases
PDCRB	01FA1H 01FD1H	7, 6	R/W	Select the sampling input clock [Hz]. 00: $fc/2^2$ 01: $fc/2^3$ 10: $fc/2^4$ 11: $fc/2^5$
		5, 4	R/W	Sampling mode. 00: When PWM is on 01: Regularly 10: When lower phases are turned on
		3 to 0	R/W	Detection position match counts 1 to 15.
PDCRA	01FA0H 01FD0H	7	W	0: No operation 1: Stop sampling in software
		6	W	0: No operation 1: Start sampling in software
		5	R/W	Stop sampling using Timer 3. 0: Disable 1: Enable
		4	R/W	Start sampling using Timer 2. 0: Disable 1: Enable
		3	R/W	Number of position signal input pins. 0: Compare three pins (PDU/PDV/PDW) 1: Compare one pin (PDU) only
		2	R/W	Count occurrences of matching when PWM is on. 0: Subsequent to matching counts when PWM previously was on 1: Eecount occurrences of matching each time PWM is on
		1	R/W	Position detection mode. 0: Ordinary mode 1: Unmatch detection mode
		0	R/W	Enable/Disable position detection function. 0: Disable 1: Enable (Sampling starts)
SDREG	01FA3H 01FD3H	6 to 0	R/W	Sampling delay. $2^3/fc \times n$ bits ( $n = 0$ to 6, maximum 50.8 $\mu$ s at 20 MHz).



## Mode Timer Control Register (MTCR), Mode Capture Register (MCAP), and Compare Registers (CMP1, CMP2, CMP3)

Name	Address	Bit	R or W	Description
MTCRB	01FA5H 01FD5H	7	R/W	Debug output. 0: Disable 1: Enable (P67 for PMD1, P77 for PMD2)
		5	R	Mode timer overflow. 0: No overflow 1: Overflowed occurred
		3	R/W	Capture mode timer by overload protection. 0: Disable 1: Enable
		2	W	Capture mode timer by software. 0: No operation 1: Capture
		1	R/W	Capture mode timer by position detection. 0: Disable 1: Enable
MTCRA	01FA4H 01FD4H	7, 6, 5	R/W	Select clock for mode timer [Hz]. 000: $f_c/2^3$ (400 ns at 20 MHz) 010: $f_c/2^4$ (800 ns at 20 MHz) 100: $f_c/2^5$ (1.6 $\mu$ s at 20 MHz) 110: $f_c/2^6$ (3.2 $\mu$ s at 20 MHz) 001: $f_c/2^7$ (6.4 $\mu$ s at 20 MHz) 011: Reserved 101: Reserved 111: Reserved
		4	R/W	Reset timer by Timer 3. 0: Disable 1: Enable
		3	R/W	Reset timer by overload protection. 0: Disable 1: Enable
		2	W	Reset timer by software. 0: No operation 1: Reset
		1	R/W	Reset timer by position detection. 0: Disable 1: Enable
		0	R/W	Enable/Disable mode timer. 0: Disable 1: Enable (timer starts)
MCAP	01FA7H, 01FA6H 01FD7H, 01FD6H	F to 0	R	Mode capture register.
CMP1	01FA9H, 01FA8H 01FD9H, 01FD8H	F to 0	R/W	Compare Register 1.
CMP2	01FABH, 01FAAH 01FDBH, 01FDAH	F to 0	R/W	Compare Register 2.
CMP3	01FADH, 01FACH 01FDDH, 01FDCH	F to 0	R/W	Compare Register 3.

PMD Control Register (MDCR), Dead Time Register (DTR), and PMD Output Register (MDOU)

Name	Address	Bit	R or W	Description
MDCRB	01FAFH 01FDFH	1, 0	R/W	Select clock for PWM counter. 00: $fc/2$ (100 ns at 20 MHz) 01: $fc/2^2$ (200 ns at 20 MHz) 10: $fc/2^3$ (400 ns at 20 MHz) 11: $fc/2^4$ (800 ns at 20 MHz)
MDCRA	01FAEH 01FDEH	7	R/W	Select half-period interrupt 0: Interrupt every period as specified in PINT. 1: Interrupt every half-period only PINT=00.
		6	R/W	DUTY mode. 0: U phase in common 1: Three phases independent
		5	R/W	Upper-phase port polarity. 0: Active low 1: Active high
		4	R/W	Lower-phase port polarity. 0: Active low 1: Active high
		3, 2	R/W	Select PWM interrupt (trigger). 00: Interrupt once every period 01: Interrupt once 2 periods 10: Interrupt once 4 periods 11: Interrupt once 8 periods
		1	R/W	PWM mode. 0: PWM mode0 (edge: sawtooth wave) 1: PWM mode1 (center: triangular wave)
		0	R/W	Enable/disable waveform synthesis function. 0: Disable 1: Enable (waveform output)
DTR	01FBEH 01FEEH	5 to 0	R/W	Set dead time. $2^3/fc \times 6\text{bit}$ (maximum 25.2 $\mu\text{s}$ at 20 MHz).
MDOU	01FB3H, 01FB2H 01FE3H, 01FE2H	F	R	0: Count up 1: Count down
		E, D, C	R/W	Comparison register for position detection. 6: W 5: V 4: U
		B	R/W	Select PWM synchronization. 0: Asynchronous with PWM period 1: Synchronized
		A	R/W	W-phase PWM output. 0: H/L level output 1: PWM waveform output
		9	R/W	V-phase PWM output. 0: H/L level output 1: PWM waveform output
		8	R/W	U-phase PWM output. 0: H/L level output 1: PWM waveform output
		7, 6	R/W	Select port output synchronizing signal. 00: Asynchronous 01: Synchronized to position detection 10: Synchronized to Timer 1 11: Synchronized to Timer 2
		5, 4	R/W	Control W-phase output
		3, 2	R/W	Control V-phase output
		1, 0	R/W	Control U-phase output

PWM Counter (MDCNT), PMD Period Register (MDPRD), and PMD Compare Registers (CMPU, CMPV, CMPW)

Name	Address	Bit	R or W	Description
MDCNT	01FB5H, 01FB4H 01FE5H, 01FE4H	B to 0	R	Read the PWM period counter value.
MDPRD	01FB7H, 01FB6H 01FE7H, 01FE6H	B to 0	R/W	PWM period MDPRD ≥ 010H.
CMPU	01FB9H, 01FB8H 01FE9H, 01FE8H	B to 0	R/W	Set U-phase PWM duty cycle.
CMPV	01FBBH, 01FBAH 01FEBH, 01FEAH	B to 0	R/W	Set V-phase PWM duty cycle.
CMPW	01FBDH, 01FBCB 01FEDH, 01FECH	B to 0	R/W	Set W-phase PWM duty cycle.

EMG Disable Code Register (EMGREL) and EMG Control Register (EMGCR)

Name	Address	Bit	R or W	Description
EMGREL	01FBFH 01FEFH	7 to 0	W	Code input for disable EMG protection circuit. Can be disable by writing 5AH and then A5H.
EMGCRB	01FB1H 01FE1H	7	W	Return from overload protective state. 0: No operation 1: Return from protective state
		6	R/W	Condition for returning from overload protective state: Synchronized to PWM. 0: Disable 1: Enable
		5	R/W	Enable/Disable return from overload protective state by timer 1. 0: Disable 1: Enable
		4	R	Overload protective state. 0: No operation 1: Under protection
		3, 2	R/W	Select output disabled phases during overload protection. 00: No phases disabled against output 01: All phases disabled against output 10: PWM phases disabled against output 11: All upper/All lower phases disabled against output
		1	R/W	Stop PWM counter (MDCNT) during overload protection. 0: Do not stop 1: Stop
		0	R/W	Enable/Disable overload protective circuit. 0: Disable 1: Enable
EMGCRA	01FB0H 01FE0H	7 to 4	R/W	Overload protection sampling time. $2^2 / f_c \times n$ (n = 1 to 15, at 20 MHz)
		2	R	EMG protective state. 0: No operation 1: Under protection
		1	W	Return from EMG protective state. 0: No operation 1: Return from protective state
		0	R/W	Enable/Disable function of the EMG protective circuit. 0: Disable 1: Enable (This circuit initially is enabled (= 1). To disable this circuit, make sure key code 5AH and A5H are written to the EMGREL1 Register beforehand.)

Electrical Angle Control Register (EDCR), Electrical Angle Period Register (EDSET), Electrical Angle Set Register (ELDEG), Voltage Set Register (AMP), and Electrical Angle Capture Register (EDCAP).

Name	Address	Bit	R or W	Description
EDCRB	01FC1H 01FF1H	3	W	0: No operation 1: Start calculation
		2	R	0: Waveform Arithmetic Circuit stopped 1: Waveform Arithmetic Circuit calculation
		1	R/W	0: Start calculation insync with electrical angle 1: Do not calculation insync with electrical angle
		0	R/W	0: Interrupt when the Electrical Angle Timer finishes counting 1: Interrupt upon end of calculation
EDCRA	01FC0H 01FF0H	7	R/W	0: Count up 1: Count down
		6	R/W	0: $V = U + 120^\circ, W = U + 240^\circ$ 1: $V = U - 120^\circ, W = U - 240^\circ$
		5, 4	R/W	Select clock. 00: $fc/2^3$ 01: $fc/2^4$ 10: $fc/2^5$ 11: $fc/2^6$
		3	R/W	Switch between 2/3-phase modulations. 0: Two-phase modulation 1: Three-phase modulation
		2	R/W	Transfer calculation result to CMP registers. 0: Disable 1: Enable
		1	R/W	Enable/disable waveform calculation function. 0: Disable 1: Enable
		0	R/W	Electrical angle timer. 0: Disable 1: Enable
EDSET	01FC3H, 01FC2H 01FF3H, 01FF2H	F to C	R/W	Correct period (n) 0 to 15 times.
		B to 0	R/W	Set period (1/m counter) $\geq$ 010H
ELDEG	01FC5H, 01FC4H 01FF5H, 01FF4H	8 to 0	R/W	Initially set and count values of electrical angle.
AMP	01FC7H, 01FC6H 01FF7H, 01FF6H	B to 0	R/W	Set voltage used during waveform calculation.
EDCAP	01FC9H, 01FC8H 01FF9H, 01FF8H	8 to 0	R	Electrical angle timer value when position is detected.
WFMDR	01FCAH 01FFAH	7 to 0	W	Set sine wave data.

Not Recommended  
for New Design



## 14.2 Control

UART is controlled by the UART Control Registers (UARTCRA, UARTCRB). The operating status can be monitored using the UART status register (UARTSR).

TXD pin and RXD pin can be selected a port assignment by UART Pin Select Register (UARTSEL).

### UART Control Register1

UARTCRA (01F91H)	7	6	5	4	3	2	1	0	
	TXE	RXE	STBT	EVEN	PE	BRG			(Initial value: 0000.0000)

TXE	Transfer operation	0: Disable 1: Enable	Write only
RXE	Receive operation	0: Disable 1: Enable	
STBT	Transmit stop bit length	0: 1 bit 1: 2 bits	
EVEN	Even-numbered parity	0: Odd-numbered parity 1: Even-numbered parity	
PE	Parity addition	0: No parity 1: Parity	
BRG	Transmit clock select	000: fc/13 [Hz] 001: fc/26 010: fc/52 011: fc/104 100: fc/208 101: fc/416 110: Input INTTC4 111: fc/96	

Note 1: When operations are disabled by setting UARTCRA<TXE and RXE> bits to "0", the setting becomes valid when data transmit or receive complete. When the transmit data is stored in the transmit data buffer, the data are not transmitted. Even if data transmit is enabled, until new data are written to the transmit data buffer, the current data are not transmitted.

Note 2: The transmit clock and the parity are common to transmit and receive.

Note 3: UARTCRA<RXE> and UARTCRA<TXE> should be set to "0" before UARTCRA<BRG> is changed.

Note 4: In case fc = 20MHz, the timer-counter 4 (TC4) is available as a baud rate generator.

### UART Control Register2

UARTCRB (01F92H)	7	6	5	4	3	2	1	0	
						RXDNC	STOPBR		(Initial value: **** *000)

RXDNC	Selection of RXD input noise rejection time	00: No noise rejection (Hysteresis input) 01: Rejects pulses shorter than 31/fc [s] as noise 10: Rejects pulses shorter than 63/fc [s] as noise 11: Rejects pulses shorter than 127/fc [s] as noise	Write only
STOPBR	Receive stop bit length	0: 1 bit 1: 2 bits	

Note: When UARTCRB<RXDNC> = "01", pulses longer than 96/fc [s] are always regarded as signals; when UARTCRB<RXDNC> = "10", longer than 192/fc [s]; and when UARTCRB<RXDNC> = "11", longer than 384/fc [s].

**UART Status Register**

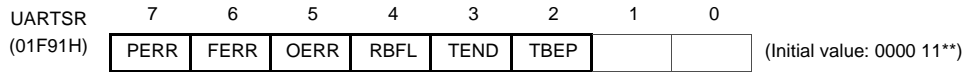

PERR	Parity error flag	0: No parity error 1: Parity error	Read only
FERR	Framing error flag	0: No framing error 1: Framing error	
OERR	Overrun error flag	0: No overrun error 1: Overrun error	
RBFL	Receive data buffer full flag	0: Receive data buffer empty 1: Receive data buffer full	
TEND	Transmit end flag	0: On transmitting 1: Transmit end	
TBEP	Transmit data buffer empty flag	0: Transmit data buffer full (Transmit data writing is finished) 1: Transmit data buffer empty	

Note: When an INTTXD is generated, TBEP flag is set to "1" automatically.

**UART Receive Data Buffer**

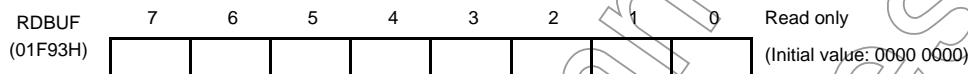

**UART Transmit Data Buffer**

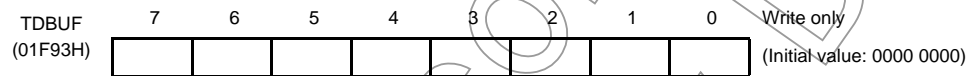

**UART Pin Select Register**

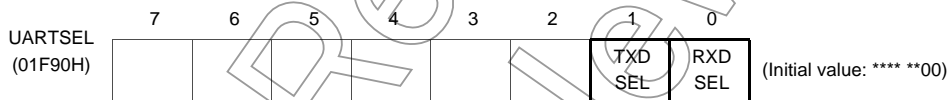

RXDSEL	RXD connect pin select	0: RXD1 1: RXD2	R/W
TXDSEL	TXD connect pin select	0: TXD1 1: TXD2	

Note 1: Do not change UARTSEL register during UART operation.

Note 2: Set UARTSEL register before performing the setting terminal of a I/O port when changing a terminal.



### 14.3 Transfer Data Format

In UART, an one-bit start bit (Low level), stop bit (Bit length selectable at high level, by UARTCRA<STBT>), and parity (Select parity in UARTCRA<PE>; even- or odd-numbered parity by UARTCRA<EVEN>) are added to the transfer data. The transfer data formats are shown as follows.

PE	STBT	Frame Length									
		1	2	3	4	5	6	7	8	9	10
0	0										
0	1										
1	0										
1	1										

Figure 14-2 Transfer Data Format

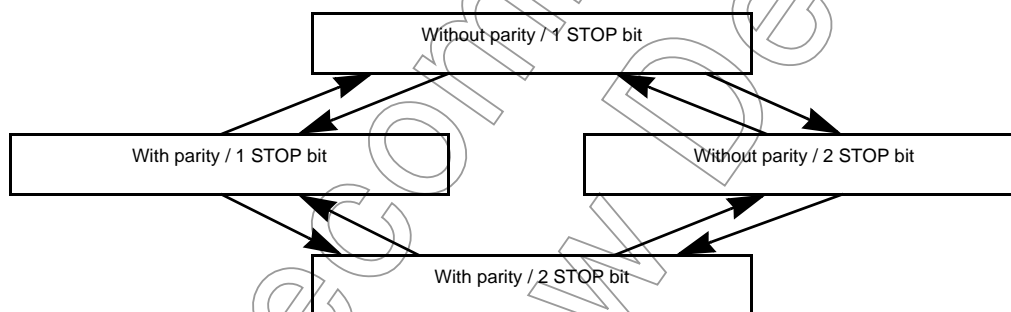

Figure 14-3 Caution on Changing Transfer Data Format

Note: In order to switch the transfer data format, perform transmit operations in the above Figure 14-3 sequence except for the initial setting.

### 14.4 Transfer Rate

The baud rate of UART is set of UARTCRA<BRG>. The example of the baud rate are shown as follows.

Table 14-1 Transfer Rate (Example)

BRG	Source Clock	
	16 MHz	8 MHz
000	76800 [baud]	38400 [baud]
001	38400	19200
010	19200	9600
011	9600	4800
100	4800	2400
101	2400	1200

When INTTC4 is used as the UART transfer rate (when UARTCRA<BRG> = "110"), the transfer clock and transfer rate are determined as follows:

$$\text{Transfer clock [Hz]} = \text{TC4 source clock [Hz]} / \text{TC4DR setting value}$$

$$\text{Transfer Rate [baud]} = \text{Transfer clock [Hz]} / 16$$

### 14.5 Data Sampling Method

The UART receiver keeps sampling input using the clock selected by UARTCRA<BRG> until a start bit is detected in RXD pin input. RT clock starts detecting "L" level of the RXD pin. Once a start bit is detected, the start bit, data bits, stop bit(s), and parity bit are sampled at three times of RT7, RT8, and RT9 during one receiver clock interval (RT clock). (RT0 is the position where the bit supposedly starts.) Bit is determined according to majority rule (The data are the same twice or more out of three samplings).

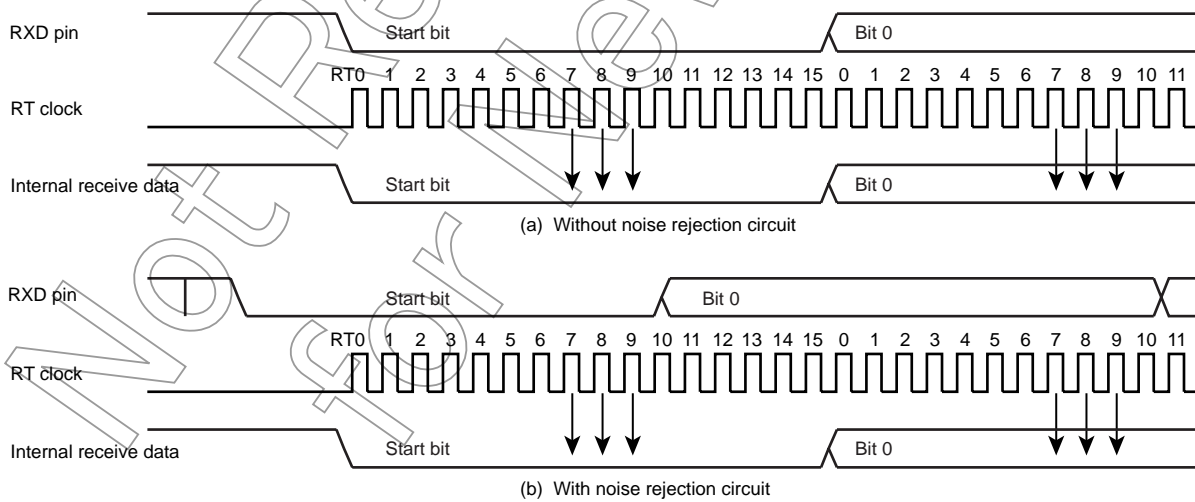

Figure 14-4 Data Sampling Method

## 14.6 STOP Bit Length

Select a transmit stop bit length (1 bit or 2 bits) by UARTCRA<STBT>.

## 14.7 Parity

Set parity / no parity by UARTCRA<PE> and set parity type (Odd- or Even-numbered) by UARTCRA<EVEN>.

## 14.8 Transmit/Receive Operation

### 14.8.1 Data Transmit Operation

Set UARTCRA<TXE> to "1". Read UARTSR to check UARTSR<TBEP> = "1", then write data in TDBUF (Transmit data buffer). Writing data in TDBUF zero-clears UARTSR<TBEP>, transfers the data to the transmit shift register and the data are sequentially output from the TXD pin. The data output include a one-bit start bit, stop bits whose number is specified in UARTCRA<STBT> and a parity bit if parity addition is specified. Select the data transfer baud rate using UARTCRA<BRG>. When data transmit starts, transmit buffer empty flag UARTSR<TBEP> is set to "1" and an INTTXD interrupt is generated.

While UARTCRA<TXE> = "0" and from when "1" is written to UARTCRA<TXE> to when send data are written to TDBUF, the TXD pin is fixed at high level. When transmitting data, first read UARTSR, then write data in TDBUF. Otherwise, UARTSR<TBEP> is not zero-cleared and transmit does not start.

### 14.8.2 Data Receive Operation

Set UARTCRA<RXE> to "1". When data are received via the RXD pin, the receive data are transferred to RDBUF (Receive data buffer). At this time, the data transmitted includes a start bit and stop bit(s) and a parity bit if parity addition is specified. When stop bit(s) are received, data only are extracted and transferred to RDBUF (Receive data buffer). Then the receive buffer full flag UARTSR<RBFL> is set and an INTRXD interrupt is generated. Select the data transfer baud rate using UARTCRA<BRG>.

If an overrun error (OERR) occurs when data are received, the data are not transferred to RDBUF (Receive data buffer) but discarded; data in the RDBUF are not affected.

Note: When a receive operation is disabled by setting UARTCRA<RXE> bit to "0", the setting becomes valid when data receive is completed. However, if a framing error occurs in data receive, the receive-disabling setting may not become valid. If a framing error occurs, be sure to perform a re-receive operation.

## 14.9 Status Flag

### 14.9.1 Parity Error

When parity determined using the receive data bits differs from the received parity bit, the parity error flag UARTSR<PERR> is set to “1”. The UARTSR<PERR> is cleared to “0” when the RDBUF is read after reading the UARTSR.

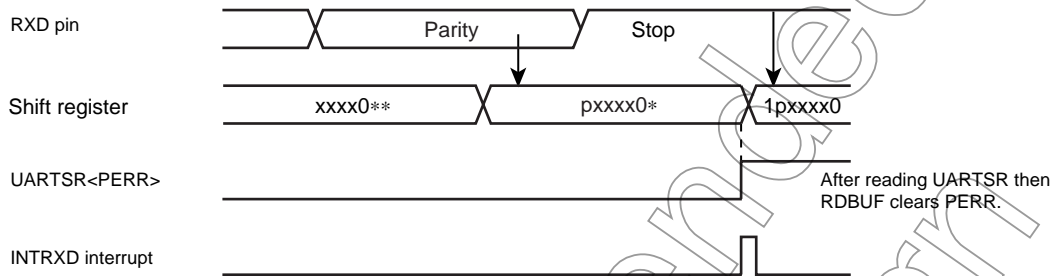

Figure 14-5 Generation of Parity Error

### 14.9.2 Framing Error

When “0” is sampled as the stop bit in the receive data, framing error flag UARTSR<FERR> is set to “1”. The UARTSR<FERR> is cleared to “0” when the RDBUF is read after reading the UARTSR.

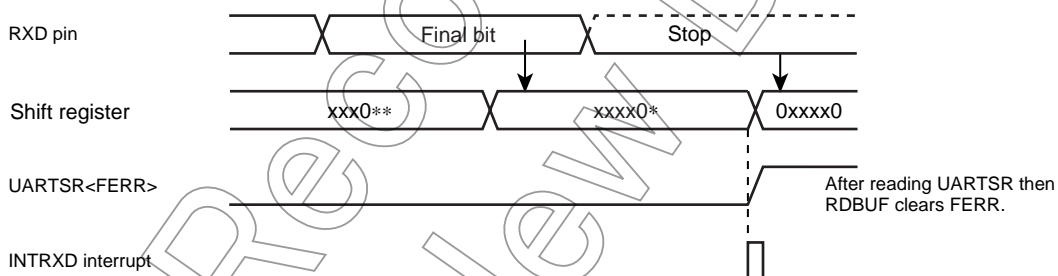

Figure 14-6 Generation of Framing Error

### 14.9.3 Overrun Error

When all bits in the next data are received while unread data are still in RDBUF, overrun error flag UARTSR<OERR> is set to “1”. In this case, the receive data is discarded; data in RDBUF are not affected. The UARTSR<OERR> is cleared to “0” when the RDBUF is read after reading the UARTSR.

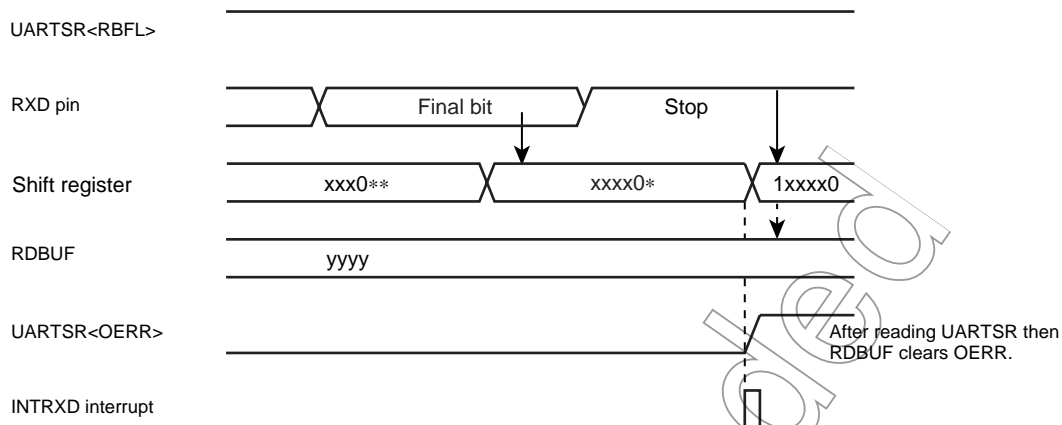

Figure 14-7 Generation of Overrun Error

Note: Receive operations are disabled until the overrun error flag UARTSR<OERR> is cleared.

#### 14.9.4 Receive Data Buffer Full

Loading the received data in RDBUF sets receive data buffer full flag UARTSR<RBFL> to "1". The UARTSR<RBFL> is cleared to "0" when the RDBUF is read after reading the UARTSR.

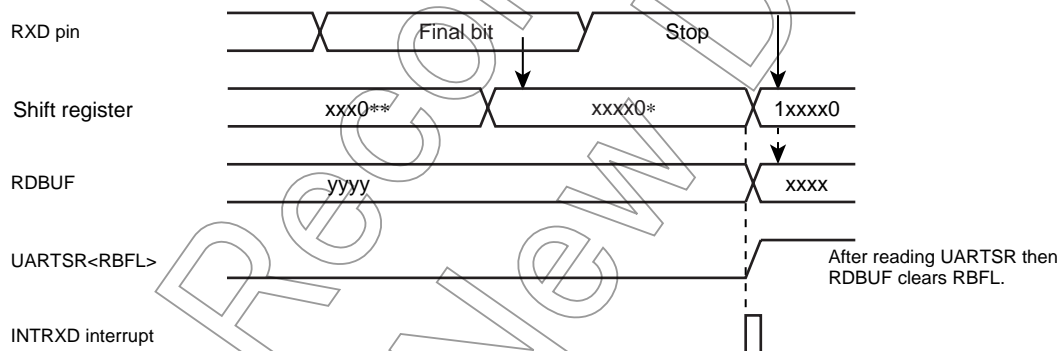

Figure 14-8 Generation of Receive Data Buffer Full

Note: If the overrun error flag UARTSR<OERR> is set during the period between reading the UARTSR and reading the RDBUF, it cannot be cleared by only reading the RDBUF. Therefore, after reading the RDBUF, read the UARTSR again to check whether or not the overrun error flag which should have been cleared still remains set.

#### 14.9.5 Transmit Data Buffer Empty

When no data is in the transmit buffer TDBUF, that is, when data in TDBUF are transferred to the transmit shift register and data transmit starts, transmit data buffer empty flag UARTSR<TBEP> is set to "1". The UARTSR<TBEP> is cleared to "0" when the TDBUF is written after reading the UARTSR.

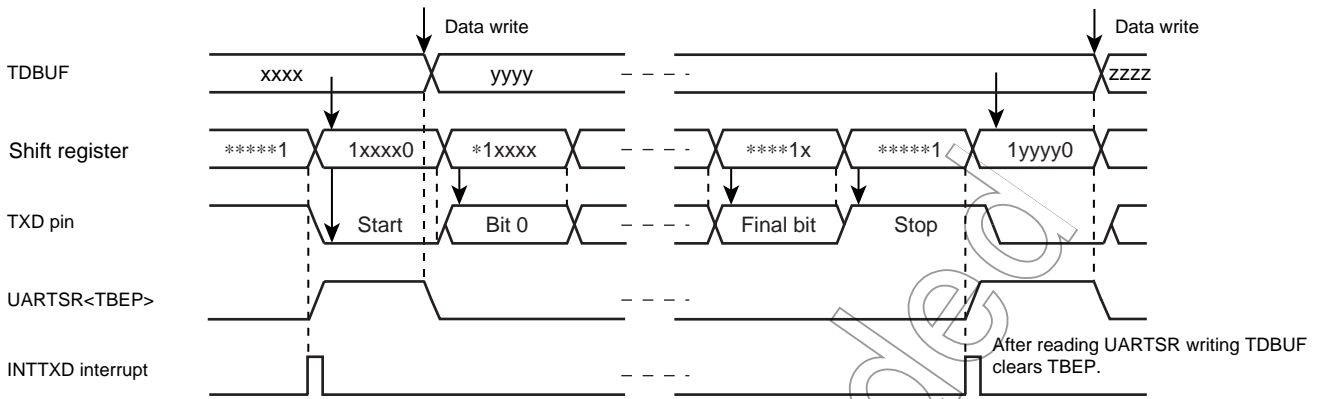

Figure 14-9 Generation of Transmit Data Buffer Empty

### 14.9.6 Transmit End Flag

When data are transmitted and no data is in TDBUF (UARTSR<TBEP> = "1"), transmit end flag UARTSR<TEND> is set to "1". The UARTSR<TEND> is cleared to "0" when the data transmit is started after writing the TDBUF.

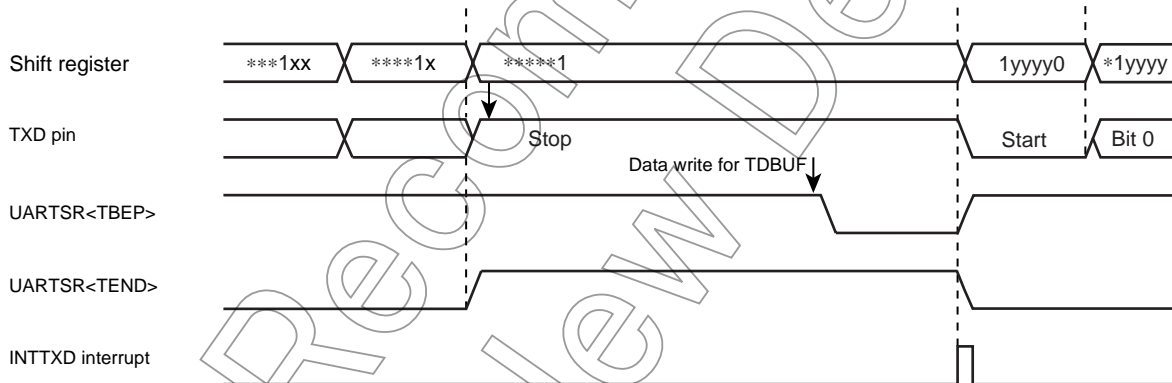

Figure 14-10 Generation of Transmit End Flag and Transmit Data Buffer Empty

Not Recommended  
for New Design

# 15. Synchronous Serial Interface (SIO)

The TMP88CS42NG has a clocked-synchronous 8-bit serial interface. Serial interface has an 8-byte transmit and receive data buffer that can automatically and continuously transfer up to 64 bits of data.

Serial interface is connected to outside peripheral devices via SO, SI, SCK port.

## 15.1 Configuration

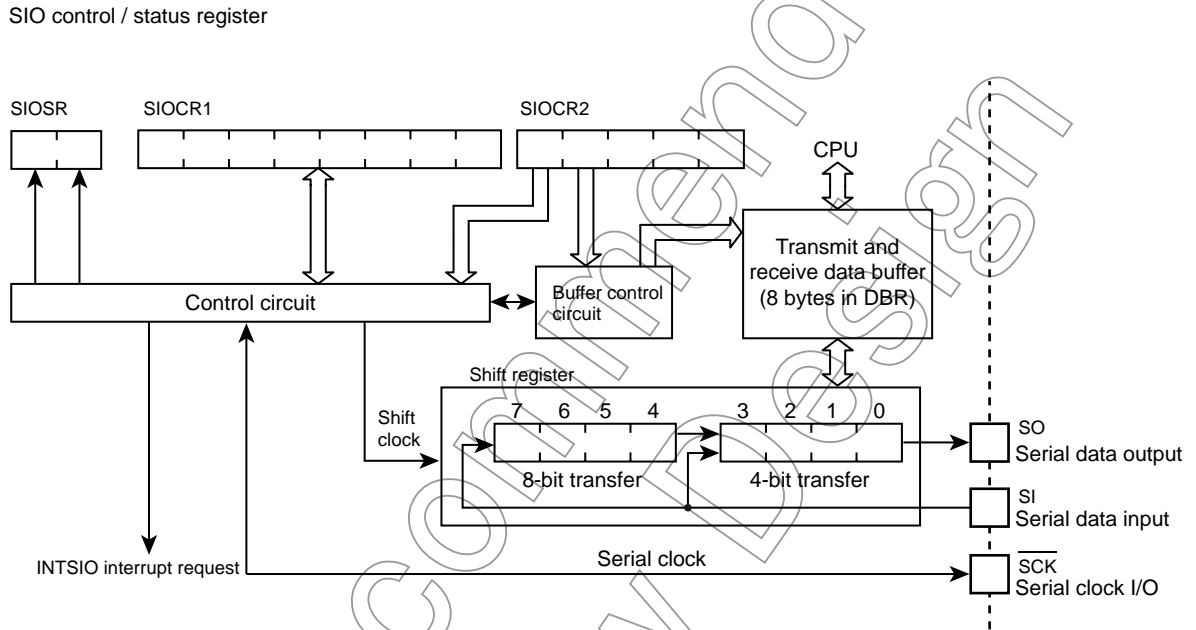

Figure 15-1 Serial Interface

Not Recommended for New Design



## 15.2 Control

The serial interface is controlled by SIO control registers (SIOCR1/SIOCR2). The serial interface status can be determined by reading SIO status register (SIOSR).

The transmit and receive data buffer is controlled by the SIOCR2<BUF>. The data buffer is assigned to address 01F98H to 01F9FH for SIO in the DBR area, and can continuously transfer up to 8 words (bytes or nibbles) at one time. When the specified number of words has been transferred, a buffer empty (in the transmit mode) or a buffer full (in the receive mode or transmit/receive mode) interrupt (INTSIO) is generated.

When the internal clock is used as the serial clock in the 8-bit receive mode and the 8-bit transmit/receive mode, a fixed interval wait can be applied to the serial clock for each word transferred. Four different wait times can be selected with SIOCR2<WAIT>.

### SIO Control Register 1

SIOCR1 (1F96H)	7	6	5	4	3	2	1	0	
	SIOS	SIOINH	SIOM			SCK			(Initial value: 0000 0000)

SIOS	Indicate transfer start / stop	0: Stop 1: Start	Write only	
SIOINH	Continue / abort transfer	0: Continuously transfer 1: Abort transfer (Automatically cleared after abort)		
SIOM	Transfer mode select	000: 8-bit transmit mode 010: 4-bit transmit mode 100: 8-bit transmit / receive mode 101: 8-bit receive mode 110: 4-bit receive mode Except the above: Reserved	Write only	
SCK	Serial clock select	NORMAL, IDLE mode		
			DV1CK = 0	DV1CK = 0
		000	$fc/2^{13}$	$fc/2^{14}$
		001	$fc/2^8$	$fc/2^9$
		010	$fc/2^7$	$fc/2^8$
		011	$fc/2^6$	$fc/2^7$
		Reserved		
		External clock (Input from SCK pin)		
		100	$fc/2^5$	$fc/2^6$
		101	$fc/2^4$	$fc/2^5$
		110	Reserved	
		111	External clock (Input from SCK pin)	

Note 1: fc: High-frequency clock [Hz]

Note 2: Set SIOCR1<SIOS> to "0" and SIOCR1<SIOINH> to "1" when setting the transfer mode or serial clock.

Note 3: SIOCR1 is write-only register, which cannot access any of in read-modify-write instruction such as bit operate, etc.

### SIO Control Register 2

SIOCR2 (1F97H)	7	6	5	4	3	2	1	0	
				WAIT			BUF		(Initial value: ***0 0000)

WAIT	Wait control	Always sets "00" except 8-bit transmit / receive mode. 00: $T_f = T_D$ (Non wait) 01: $T_f = 2T_D$ (Wait) 10: $T_f = 4T_D$ (Wait) 11: $T_f = 8T_D$ (Wait)	
BUF	Number of transfer words (Buffer address in use)	000: 1 word transfer 01F98H 001: 2 words transfer 01F98H ~ 01F99H 010: 3 words transfer 01F98H ~ 01F9AH 011: 4 words transfer 01F98H ~ 01F9BH 100: 5 words transfer 01F98H ~ 01F9CH 101: 6 words transfer 01F98H ~ 01F9DH 110: 7 words transfer 01F98H ~ 01F9EH 111: 8 words transfer 01F98H ~ 01F9FH	Write only

- Note 1: The lower 4 bits of each buffer are used during 4-bit transfers. Zeros (0) are stored to the upper 4bits when receiving.
- Note 2: Transmitting starts at the lowest address. Received data are also stored starting from the lowest address to the highest address. ( The first buffer address transmitted is 01F98H ).
- Note 3: The value to be loaded to BUF is held after transfer is completed.
- Note 4: SIOCR2 must be set when the serial interface is stopped (SIOF = 0).
- Note 5: \*: Don't care
- Note 6: SIOCR2 is write-only register, which cannot access any of in read-modify-write instruction such as bit operate, etc.
- Note 7:  $T_f$ : Frame time,  $T_D$ : Data transfer time

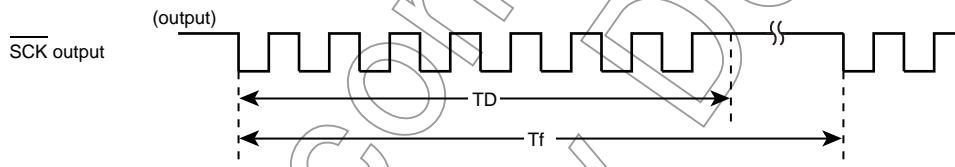

Figure 15-2 Frame time ( $T_f$ ) and Data transfer time ( $T_D$ )

SIO Status Register

SIOSR	7	6	5	4	3	2	1	0	
(1F97H)	SIOF	SEF							(Initial value: 00** ****)

SIOF	Serial transfer operating status monitor	0: Transfer terminated 1: Transfer in process	Read only
SEF	Shift operating status monitor	0: Shift operation terminated 1: Shift operation in process	

Note 1: After SIOCR1<SIOS> is cleared to "0", SIOSR<SIOF> is cleared to "0" at the termination of transfer or the setting of SIOCR1<SIOINH> to "1".

### 15.3 Serial clock

#### 15.3.1 Clock source

Internal clock or external clock for the source clock is selected by SIOCR1<SCK>.

### 15.3.1.1 Internal clock

Any of six frequencies can be selected. The serial clock is output to the outside on the SCK pin. The SCK pin goes high when transfer starts.

When data writing (in the transmit mode) or reading (in the receive mode or the transmit/receive mode) cannot keep up with the serial clock rate, there is a wait function that automatically stops the serial clock and holds the next shift operation until the read/write processing is completed.

Table 15-1 Serial Clock Rate

NORMAL, IDLE mode		
SCK	Clock	Baud Rate
000	$fc/2^{13}$	2.44 Kbps
001	$fc/2^8$	78.13 Kbps
010	$fc/2^7$	156.25 Kbps
011	$fc/2^6$	312.50 Kbps
100	$fc/2^5$	625.00 Kbps
101	$fc/2^4$	125.00 Kbps
110	-	-
111	External	External

Note: 1 Kbit = 1024 bit ( $fc = 20$  MHz).

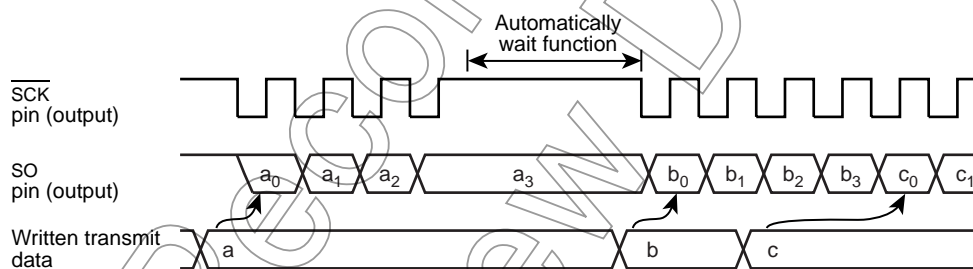

Figure 15-3 Automatic Wait Function (at 4-bit transmit mode)

### 15.3.1.2 External clock

An external clock connected to the  $\overline{\text{SCK}}$  pin is used as the serial clock. In this case, the  $\overline{\text{SCK}}$  (P43) port should be set to input mode. To ensure shifting, a pulse width of more than  $2^4/fc$  is required. This pulse is needed for the shift operation to execute certainly. Actually, there is necessary processing time for interrupting, writing, and reading. The minimum pulse is determined by setting the mode and the program.

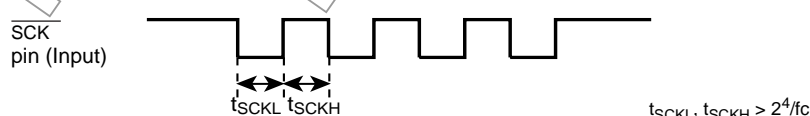

Figure 15-4 External clock pulse width

### 15.3.2 Shift edge

The leading edge is used to transmit, and the trailing edge is used to receive.

#### 15.3.2.1 Leading edge

Transmitted data are shifted on the leading edge of the serial clock (falling edge of the  $\overline{\text{SCK}}$  pin input/output).

#### 15.3.2.2 Trailing edge

Received data are shifted on the trailing edge of the serial clock (rising edge of the  $\overline{\text{SCK}}$  pin input/output).

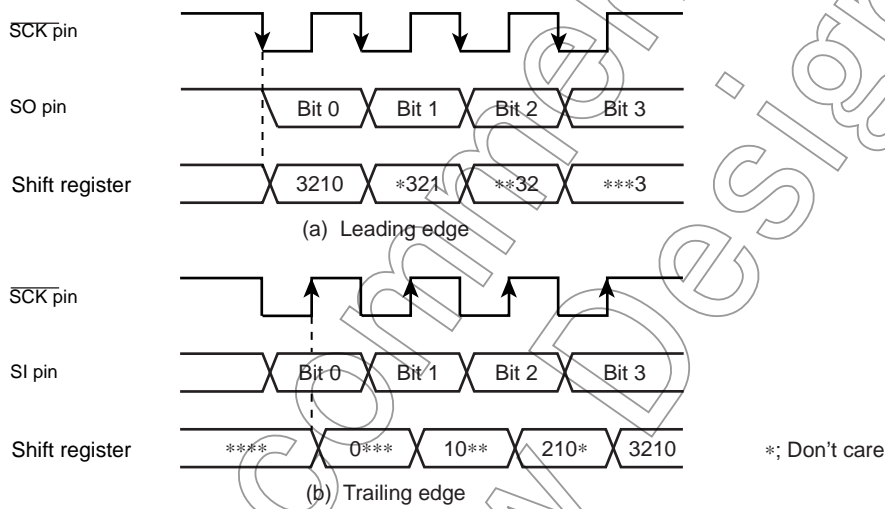

Figure 15-5 Shift edge

### 15.4 Number of bits to transfer

Either 4-bit or 8-bit serial transfer can be selected. When 4-bit serial transfer is selected, only the lower 4 bits of the transmit/receive data buffer register are used. The upper 4 bits are cleared to “0” when receiving. The data is transferred in sequence starting at the least significant bit (LSB).

### 15.5 Number of words to transfer

Up to 8 words consisting of 4 bits of data (4-bit serial transfer) or 8 bits (8-bit serial transfer) of data can be transferred continuously. The number of words to be transferred can be selected by  $\text{SIOCR2}\langle\text{BUF}\rangle$ .

An INTSIO interrupt is generated when the specified number of words has been transferred. If the number of words is to be changed during transfer, the serial interface must be stopped before making the change. The number of words can be changed during automatic-wait operation of an internal clock. In this case, the serial interface is not required to be stopped.

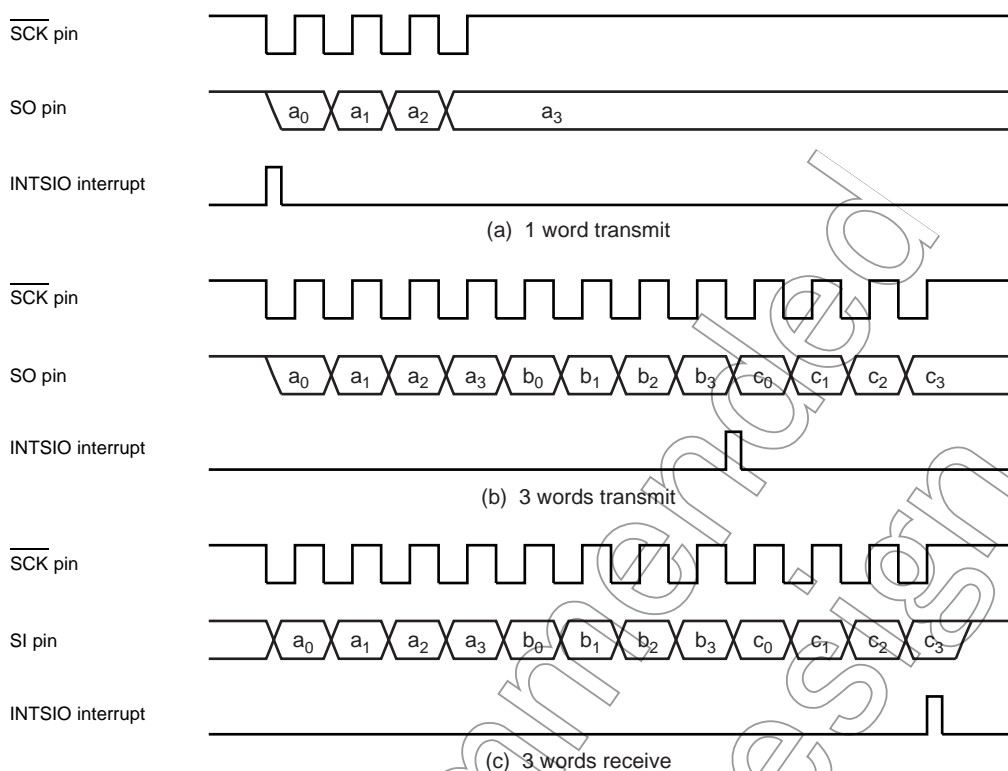

Figure 15-6 Number of words to transfer (Example: 1 word = 4bit)

## 15.6 Transfer Mode

SIOCR1<SIOM> is used to select the transmit, receive, or transmit/receive mode.

### 15.6.1 4-bit and 8-bit transfer modes

In these modes, firstly set the SIO control register to the transmit mode, and then write first transmit data (number of transfer words to be transferred) to the data buffer registers (DBR).

After the data are written, the transmission is started by setting SIOCR1<SIOS> to “1”. The data are then output sequentially to the SO pin in synchronous with the serial clock, starting with the least significant bit (LSB). As soon as the LSB has been output, the data are transferred from the data buffer register to the shift register. When the final data bit has been transferred and the data buffer register is empty, an INTSIO (Buffer empty) interrupt is generated to request the next transmitted data.

When the internal clock is used, the serial clock will stop and an automatic-wait will be initiated if the next transmitted data are not loaded to the data buffer register by the time the number of data words specified with the SIOCR2<BUF> has been transmitted. Writing even one word of data cancels the automatic-wait; therefore, when transmitting two or more words, always write the next word before transmission of the previous word is completed.

Note: Automatic waits are also canceled by writing to a DBR not being used as a transmit data buffer register; therefore, during SIO do not use such DBR for other applications. For example, when 3 words are transmitted, do not use the DBR of the remained 5 words.

When an external clock is used, the data must be written to the data buffer register before shifting next data. Thus, the transfer speed is determined by the maximum delay time from the generation of the interrupt request to writing of the data to the data buffer register by the interrupt service program.

The transmission is ended by clearing SIOCR1<SIOS> to “0” or setting SIOCR1<SIOINH> to “1” in buffer empty interrupt service program.

SIOCR1<SIOS> is cleared, the operation will end after all bits of words are transmitted.

That the transmission has ended can be determined from the status of SIOSR<SIOF> because SIOSR<SIOF> is cleared to “0” when a transfer is completed.

When SIOCR1<SIOINH> is set, the transmission is immediately ended and SIOSR<SIOF> is cleared to “0”.

When an external clock is used, it is also necessary to clear SIOCR1<SIOS> to “0” before shifting the next data; If SIOCR1<SIOS> is not cleared before shift out, dummy data will be transmitted and the operation will end.

If it is necessary to change the number of words, SIOCR1<SIOS> should be cleared to “0”, then SIOCR2<BUF> must be rewritten after confirming that SIOSR<SIOF> has been cleared to “0”.

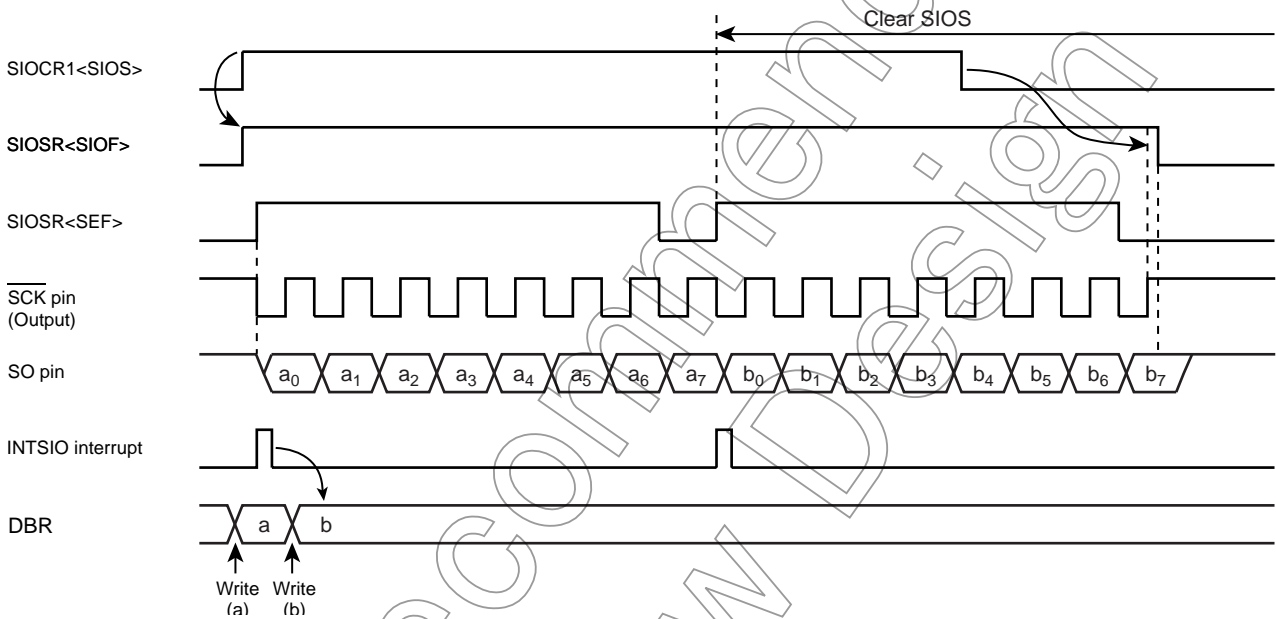

Figure 15-7 Transfer Mode (Example: 8bit, 1word transfer, Internal clock)

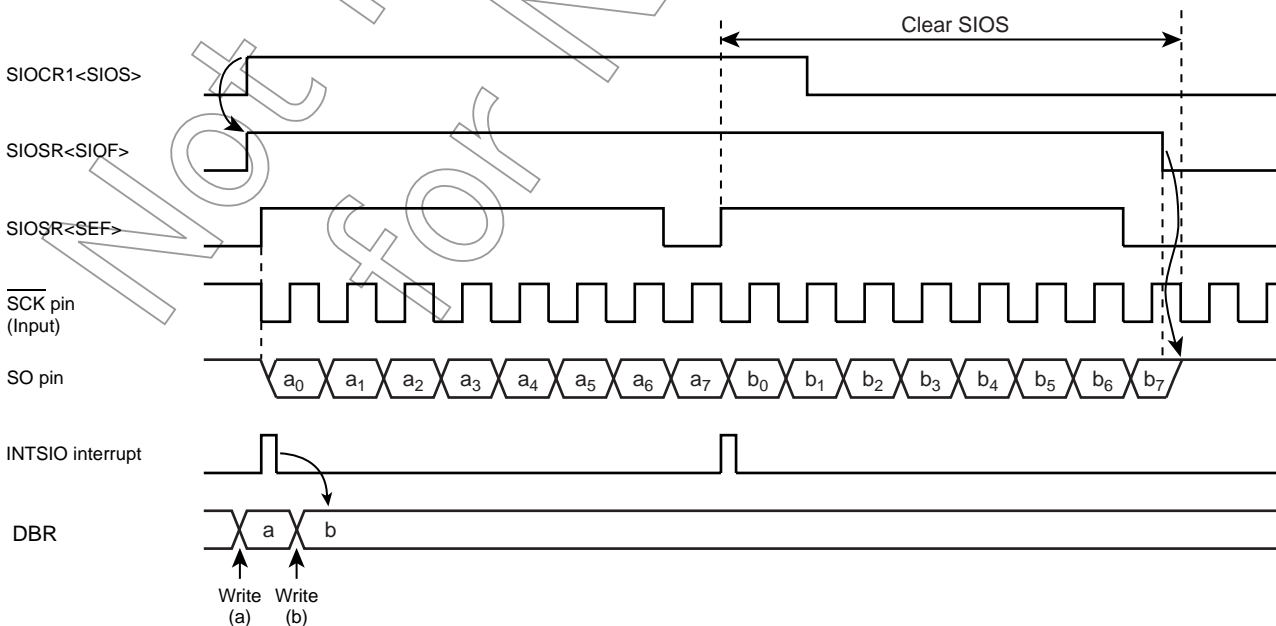

Figure 15-8 Transfer Mode (Example: 8bit, 1word transfer, External clock)

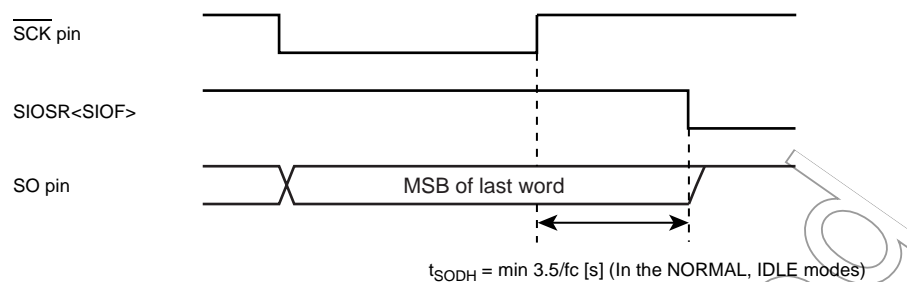

Figure 15-9 Transmitted Data Hold Time at End of Transfer

### 15.6.2 4-bit and 8-bit receive modes

After setting the control registers to the receive mode, set `SIOCR1<SIOS>` to “1” to enable receiving. The data are then transferred to the shift register via the `SI` pin in synchronous with the serial clock. When one word of data has been received, it is transferred from the shift register to the data buffer register (DBR). When the number of words specified with the `SIOCR2<BUF>` has been received, an `INTSIO` (Buffer full) interrupt is generated to request that these data be read out. The data are then read from the data buffer registers by the interrupt service program.

When the internal clock is used, and the previous data are not read from the data buffer register before the next data are received, the serial clock will stop and an automatic-wait will be initiated until the data are read. A wait will not be initiated if even one data word has been read.

Note: Waits are also canceled by reading a DBR not being used as a received data buffer register is read; therefore, during SIO do not use such DBR for other applications.

When an external clock is used, the shift operation is synchronized with the external clock; therefore, the previous data are read before the next data are transferred to the data buffer register. If the previous data have not been read, the next data will not be transferred to the data buffer register and the receiving of any more data will be canceled. When an external clock is used, the maximum transfer speed is determined by the delay between the time when the interrupt request is generated and when the data received have been read.

The receiving is ended by clearing `SIOCR1<SIOS>` to “0” or setting `SIOCR1<SIOINH>` to “1” in buffer full interrupt service program.

When `SIOCR1<SIOS>` is cleared, the current data are transferred to the buffer. After `SIOCR1<SIOS>` cleared, the receiving is ended at the time that the final bit of the data has been received. That the receiving has ended can be determined from the status of `SIOSR<SIOF>`. `SIOSR<SIOF>` is cleared to “0” when the receiving is ended. After confirmed the receiving termination, the final receiving data is read. When `SIOCR1<SIOINH>` is set, the receiving is immediately ended and `SIOSR<SIOF>` is cleared to “0”. (The received data is ignored, and it is not required to be read out.)

If it is necessary to change the number of words in external clock operation, `SIOCR1<SIOS>` should be cleared to “0” then `SIOCR2<BUF>` must be rewritten after confirming that `SIOSR<SIOF>` has been cleared to “0”. If it is necessary to change the number of words in internal clock, during automatic-wait operation which occurs after completion of data receiving, `SIOCR2<BUF>` must be rewritten before the received data is read out.

Note: The buffer contents are lost when the transfer mode is switched. If it should become necessary to switch the transfer mode, end receiving by clearing `SIOCR1<SIOS>` to “0”, read the last data and then switch the transfer mode.

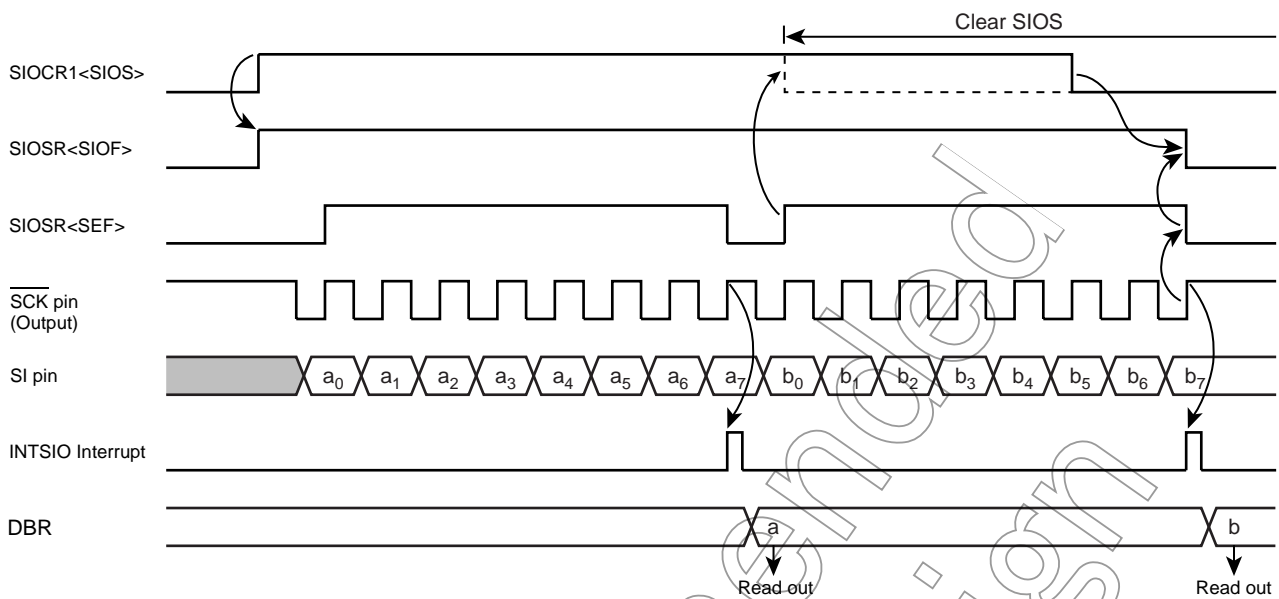

Figure 15-10 Receive Mode (Example: 8bit, 1word transfer, Internal clock)

### 15.6.3 8-bit transfer / receive mode

After setting the SIO control register to the 8-bit transmit/receive mode, write the data to be transmitted first to the data buffer registers (DBR). After that, enable the transmit/receive by setting SIOCR1<SIOS> to "1". When transmitting, the data are output from the SO pin at leading edges of the serial clock. When receiving, the data are input to the SI pin at the trailing edges of the serial clock. When the all receive is enabled, 8-bit data are transferred from the shift register to the data buffer register. An INTSIO interrupt is generated when the number of data words specified with the SIOCR2<BUF> has been transferred. Usually, read the receive data from the buffer register in the interrupt service. The data buffer register is used for both transmitting and receiving; therefore, always write the data to be transmitted after reading the all received data.

When the internal clock is used, a wait is initiated until the received data are read and the next transfer data are written. A wait will not be initiated if even one transfer data word has been written.

When an external clock is used, the shift operation is synchronized with the external clock; therefore, it is necessary to read the received data and write the data to be transmitted next before starting the next shift operation. When an external clock is used, the transfer speed is determined by the maximum delay between generation of an interrupt request and the received data are read and the data to be transmitted next are written.

The transmit/receive operation is ended by clearing SIOCR1<SIOS> to "0" or setting SIOCR1<SIOINH> to "1" in INTSIO interrupt service program.

When SIOCR1<SIOS> is cleared, the current data are transferred to the buffer. After SIOCR1<SIOS> cleared, the transmitting/receiving is ended at the time that the final bit of the data has been transmitted.

That the transmitting/receiving has ended can be determined from the status of SIOSR<SIOF>. SIOSR<SIOF> is cleared to "0" when the transmitting/receiving is ended.

When SIOCR1<SIOINH> is set, the transmit/receive operation is immediately ended and SIOSR<SIOF> is cleared to "0".

If it is necessary to change the number of words in external clock operation, SIOCR1<SIOS> should be cleared to "0", then SIOCR2<BUF> must be rewritten after confirming that SIOSR<SIOF> has been cleared to "0".

If it is necessary to change the number of words in internal clock, during automatic-wait operation which occurs after completion of transmit/receive operation, SIOCR2<BUF> must be rewritten before reading and writing of the receive/transmit data.



Note: The buffer contents are lost when the transfer mode is switched. If it should become necessary to switch the transfer mode, end receiving by clearing SIOCR1<SIOS> to "0", read the last data and then switch the transfer mode.

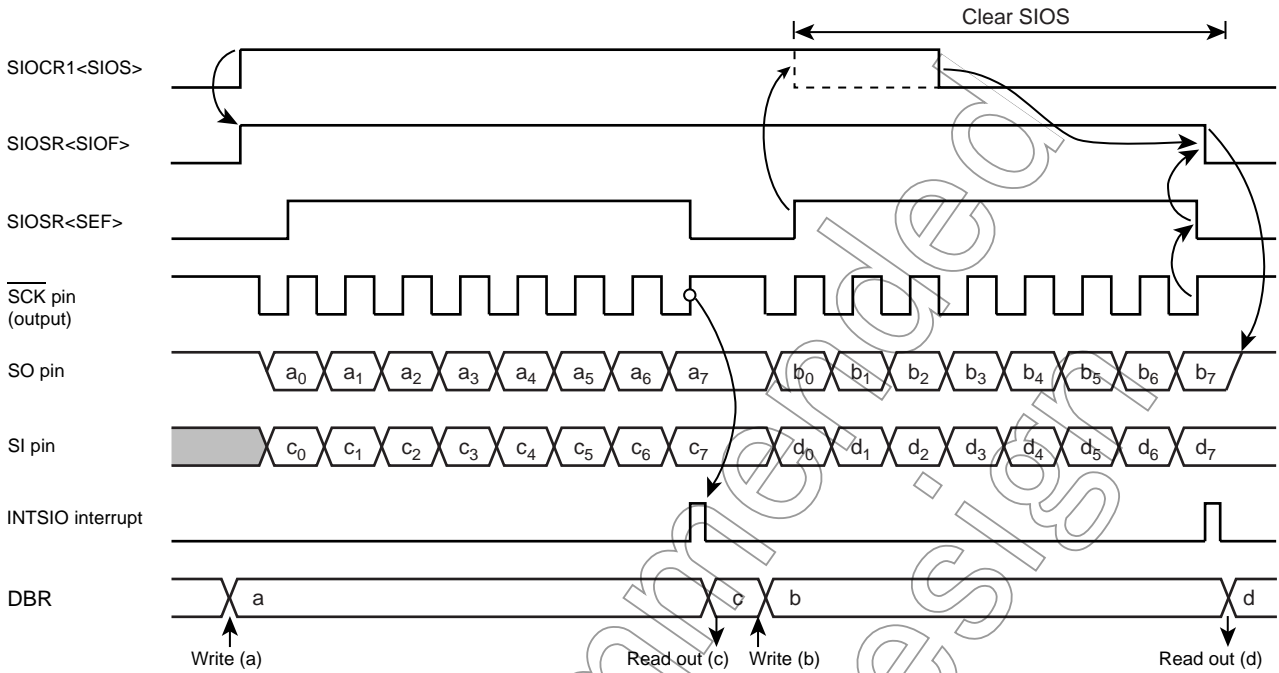

Figure 15-11 Transfer / Receive Mode (Example: 8bit, 1word transfer, Internal clock)

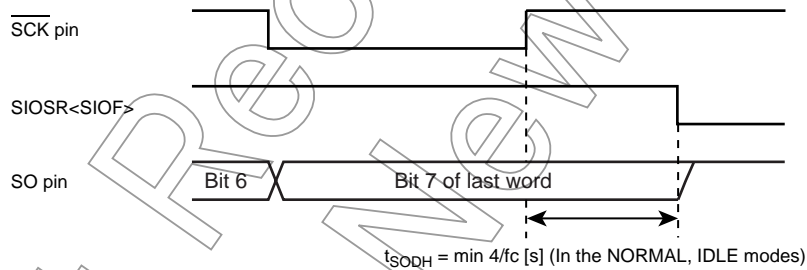

Figure 15-12 Transmitted Data Hold Time at End of Transfer / Receive

# 16. 10-bit AD Converter (ADC)

The TMP88CS42NG have a 10-bit successive approximation type AD converter.

## 16.1 Configuration

The circuit configuration of the 10-bit AD converter is shown in Figure 16-1.

It consists of control register ADCCRA and ADCCRB, converted value register ADCDRH and ADCDRL, a DA converter, a sample-hold circuit, a comparator, and a successive comparison circuit.

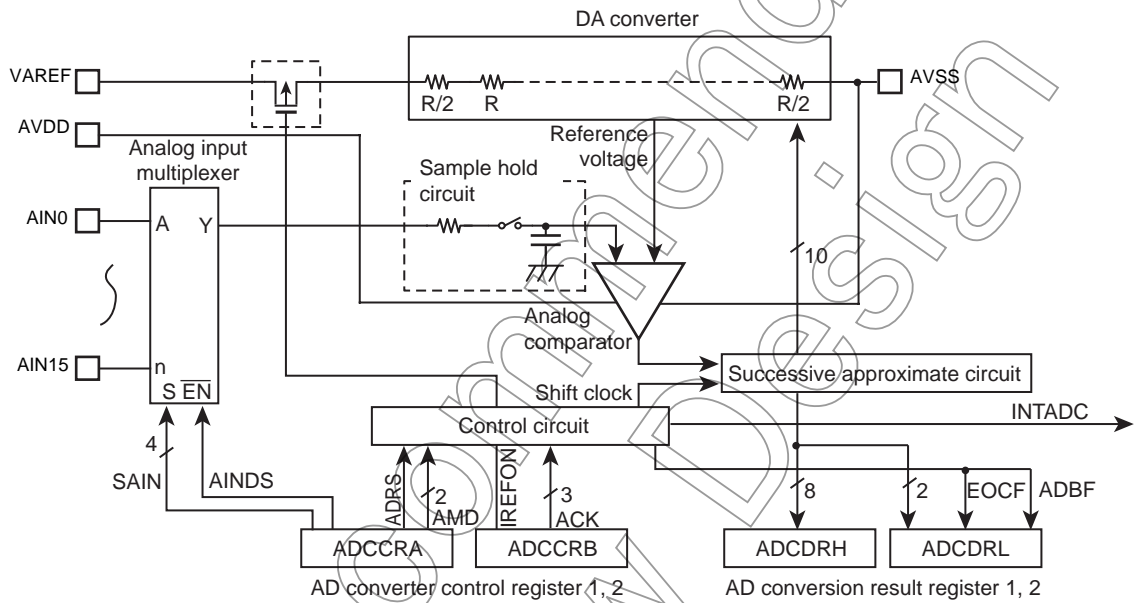

Note: Before using AD converter, set appropriate value to I/O port register combining a analog input port. For details, see the section on "I/O ports".

Figure 16-1 10-bit AD Converter

## 16.2 Register configuration

The AD converter consists of the following four registers:

1. AD converter control register 1 (ADCCRA)

This register selects the analog channels and operation mode (Software start or repeat) in which to perform AD conversion and controls the AD converter as it starts operating.

2. AD converter control register 2 (ADCCRB)

This register selects the AD conversion time and controls the connection of the DA converter (Ladder resistor network).

3. AD converted value register 1 (ADCDRH)

This register used to store the digital value after being converted by the AD converter.

4. AD converted value register 2 (ADCDRL)

This register monitors the operating status of the AD converter.

### AD Converter Control Register 1

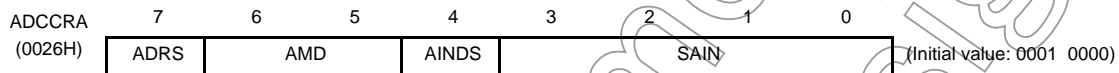

ADRS	AD conversion start	0: - 1: AD conversion start	R/W
AMD	AD operating mode	00: AD operation disable 01: Software start mode 10: Reserved 11: Repeat mode	
AINDS	Analog input control	0: Analog input enable 1: Analog input disable	
SAIN	Analog input channel select	0000: AIN0 0001: AIN1 0010: AIN2 0011: AIN3 0100: AIN4 0101: AIN5 0110: AIN6 0111: AIN7 1000: AIN8 1001: AIN9 1010: AIN10 1011: AIN11 1100: AIN12 1101: AIN13 1110: AIN14 1111: AIN15	

Note 1: Select analog input channel during AD converter stops (ADCDRL<ADBF> = "0").

Note 2: When the analog input channel is all use disabling, the ADCCRA<AINDS> should be set to "1".

Note 3: During conversion, Do not perform port output instruction to maintain a precision for all of the pins because analog input port use as general input port. And for port near to analog input, Do not input intense signaling of change.

Note 4: The ADCCRA<ADRS> is automatically cleared to "0" after starting conversion.

Note 5: Do not set ADCCRA<ADRS> newly again during AD conversion. Before setting ADCCRA<ADRS> newly again, check ADCDRL<EOCF> to see that the conversion is completed or wait until the interrupt signal (INTADC) is generated (e.g., interrupt handling routine).

Note 6: After STOP mode is started, AD converter control register1 (ADCCRA) is all initialized and no data can be written in this register. Therefore, to use AD converter again, set the ADCCRA newly after returning to NORMAL mode.

Note 7: After RESET, ADCCRA<SAIN> is initialized Reserved setting. Therefore, set the appropriate analog input channel to ADC-CRA<SAIN> when use AD converter.

Note 8: After ADCCRA is set to 00H, AD conversion can not be started for four cycles. Thus, four NOPs must be inserted before setting the ADCCRA<ADRS>.

AD Converter Control Register 2

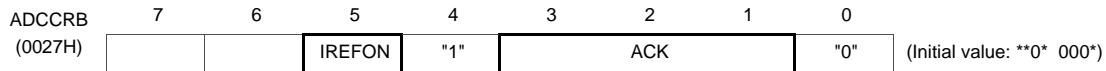

IREFON	DA converter (Ladder resistor) connection control	0: Connected only during AD conversion 1: Always connected	
ACK	AD conversion time select (Refer to the following table about the conversion time)	000: 39/fc 001: Reserved 010: 78/fc 011: 156/fc 100: 312/fc 101: 624/fc 110: 1248/fc 111: Reserved	R/W

- Note 1: Always set bit0 in ADCCRB to "0" and set bit4 in ADCCRB to "1".
- Note 2: When a read instruction for ADCCRB, bit6 to 7 in ADCCRB read in as undefined data.
- Note 3: After STOP mode is started, AD converter control register2 (ADCCRB) is all initialized and no data can be written in this register. Therefore, to use AD converter again, set the ADCCRB newly after returning to NORMAL mode.

Table 16-1 ACK setting and Conversion time (at CGCR<DV1CK>="0")

Condition ACK	Conversion time	20 MHz	16 MHz	8 MHz
000	39/fc	-	-	-
001	Reserved			
010	78/fc	-	-	-
011	156/fc	-	-	19.5 μs
100	312/fc	15.6 μs	19.5 μs	39.0 μs
101	624/fc	31.2 μs	39.0 μs	78.0 μs
110	1248/fc	62.4 μs	78.0 μs	156.0 μs
111	Reserved			

Table 16-2 ACK setting and Conversion time (at CGCR<DV1CK>="1")

Condition ACK	Conversion time	20 MHz	16 MHz	8 MHz
000	39/fc	-	-	-
001	Reserved			
010	78/fc	-	-	-
011	156/fc	-	-	19.5 μs
100	312/fc	15.6 μs	19.5 μs	39.0 μs
101	624/fc	31.2 μs	39.0 μs	78.0 μs
110	1248/fc	62.4 μs	78.0 μs	156.0 μs
111	Reserved			

- Note 1: Setting for "-" in the above table are inhibited.      fc: High Frequency oscillation clock [Hz]
- Note 2: Set conversion time setting should be kept more than the following time by Analog reference voltage (VAREF).

- VAREF = 4.5 to 5.5 V      15.6 μs and more

AD Converted value Register 1

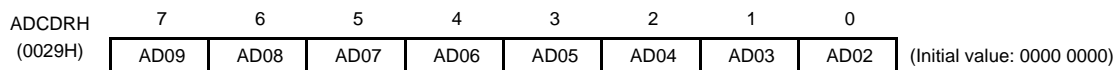

AD Converted value Register 2

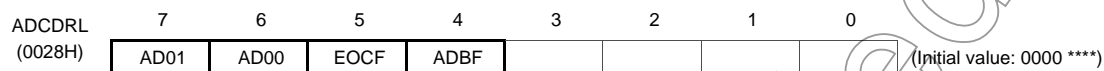

EOCF	AD conversion end flag	0: Before or during conversion 1: Conversion completed	Read only
ADBF	AD conversion BUSY flag	0: During stop of AD conversion 1: During AD conversion	

Note 1: The ADCDRL<EOCF> is cleared to "0" when reading the ADCDRH. Therefore, the AD conversion result should be read to ADCDRL more first than ADCDRH.

Note 2: The ADCDRL<ADBF> is set to "1" when AD conversion starts, and cleared to "0" when AD conversion finished. It also is cleared upon entering STOP mode.

Note 3: If a read instruction is executed for ADCDRL, read data of bit3 to bit0 are unstable.

Not Recommended for New Design

## 16.3 Function

### 16.3.1 Software Start Mode

After setting ADCCRA<AMD> to “01” (software start mode), set ADCCRA<ADRS> to “1”. AD conversion of the voltage at the analog input pin specified by ADCCRA<SAIN> is thereby started.

After completion of the AD conversion, the conversion result is stored in AD converted value registers (ADCDRH, ADCDRL) and at the same time ADCDRL<EOCF> is set to 1, the AD conversion finished interrupt (INTADC) is generated.

ADRS is automatically cleared after AD conversion has started. Do not set ADCCRA<ADRS> newly again (Restart) during AD conversion. Before setting ADCCRA<ADRS> newly again, check ADCDRL<EOCF> to see that the conversion is completed or wait until the interrupt signal (INTADC) is generated (e.g., interrupt handling routine).

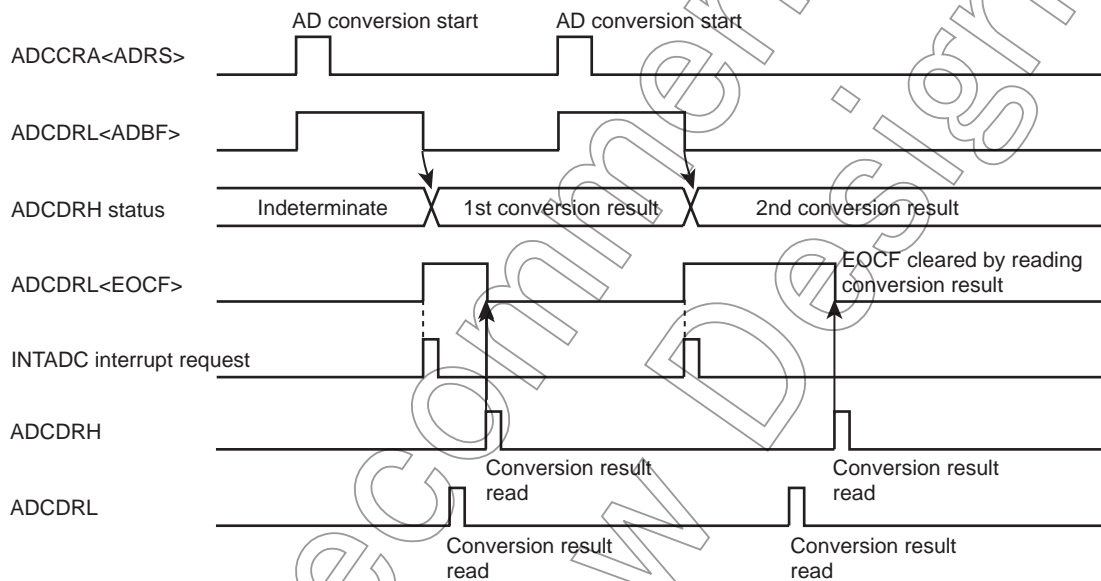

Figure 16-2 Software Start Mode

### 16.3.2 Repeat Mode

AD conversion of the voltage at the analog input pin specified by ADCCRA<SAIN> is performed repeatedly. In this mode, AD conversion is started by setting ADCCRA<ADRS> to “1” after setting ADCCRA<AMD> to “11” (Repeat mode).

After completion of the AD conversion, the conversion result is stored in AD converted value registers (ADCDRH, ADCDRL) and at the same time ADCDRL<EOCF> is set to 1, the AD conversion finished interrupt (INTADC) is generated.

In repeat mode, each time one AD conversion is completed, the next AD conversion is started. To stop AD conversion, set ADCCRA<AMD> to “00” (Disable mode) by writing 0s. The AD convert operation is stopped immediately. The converted value at this time is not stored in the AD converted value register.

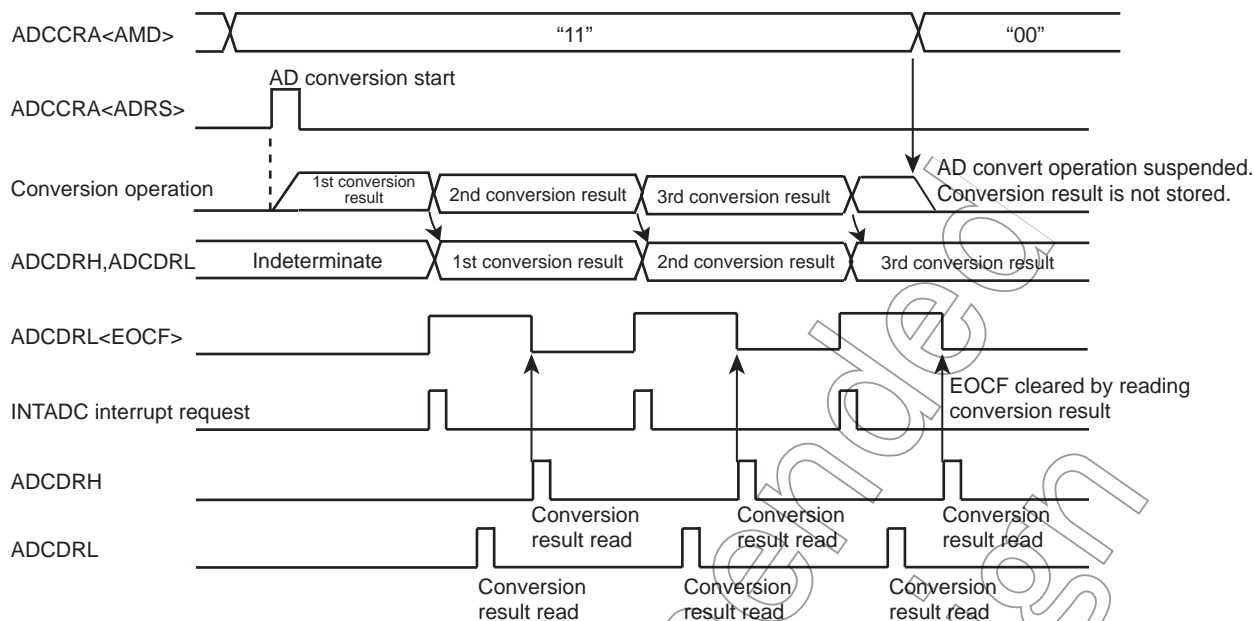

Figure 16-3 Repeat Mode

### 16.3.3 Register Setting

1. Set up the AD converter control register 1 (ADCCRA) as follows:
  - Choose the channel to AD convert using AD input channel select (SAIN).
  - Specify analog input enable for analog input control (AINDS).
  - Specify AMD for the AD converter control operation mode (software or repeat mode).
2. Set up the AD converter control register 2 (ADCCRB) as follows:
  - Set the AD conversion time using AD conversion time (ACK). For details on how to set the conversion time, refer to Figure 16-1, Figure 16-2 and AD converter control register 2.
  - Choose IREFON for DA converter control.
3. After setting up (1) and (2) above, set AD conversion start (ADRS) of AD converter control register 1 (ADCCRA) to "1". If software start mode has been selected, AD conversion starts immediately.
4. After an elapse of the specified AD conversion time, the AD converted value is stored in AD converted value register 1 (ADCDRH) and the AD conversion finished flag (EOCF) of AD converted value register 2 (ADCDRL) is set to "1", upon which time AD conversion interrupt INTADC is generated.
5. EOCF is cleared to "0" by a read of the conversion result. However, if reconverted before a register read, although EOCF is cleared the previous conversion result is retained until the next conversion is completed.

Example :After selecting the conversion time 15.6  $\mu$ s at 20 MHz and the analog input channel AIN4 pin, perform AD conversion once. After checking EOCF, read the converted value, store the lower 2 bits in address 0009EH and store the upper 8 bits in address 0009FH in RAM. The operation mode is software start mode.

```

: (port setting)      :      ;Set port register appropriately before setting AD
                        :      ;converter registers.
:                    :      ;(Refer to section I/O port in details)
LD                    (ADCCRA) , 00100100B ; Select Software start mode, Analog input enable,
                        :      ;and AIN4
LD                    (ADCCRB) , 00011000B ;Select conversion time(312/fc) and operation
                        :      ;mode
SLOOP : SET          (ADCCRA) . 7          ; ADRS = 1(AD conversion start)
      : TEST         (ADCDRB) . 5          ; EOCF= 1 ?
      : JRS          T, SLOOP
      :
      : LD           A , (ADCDDL)          ; Read result data
      : LD           (9EH) , A
      : LD           A , (ADCDRH)          ; Read result data
      : LD           (9FH) , A
    
```

### 16.4 STOP mode during AD Conversion

When standby mode (STOP mode) is entered forcibly during AD conversion, the AD convert operation is suspended and the AD converter is initialized (ADCCRA and ADCCRB are initialized to initial value). Also, the conversion result is indeterminate. (Conversion results up to the previous operation are cleared, so be sure to read the conversion results before entering standby mode (STOP mode).) When restored from standby mode (STOP mode), AD conversion is not automatically restarted, so it is necessary to restart AD conversion. Note that since the analog reference voltage is automatically disconnected, there is no possibility of current flowing into the analog reference voltage.



## 16.5 Analog Input Voltage and AD Conversion Result

The analog input voltage is corresponded to the 10-bit digital value converted by the AD as shown in Figure 16-4.

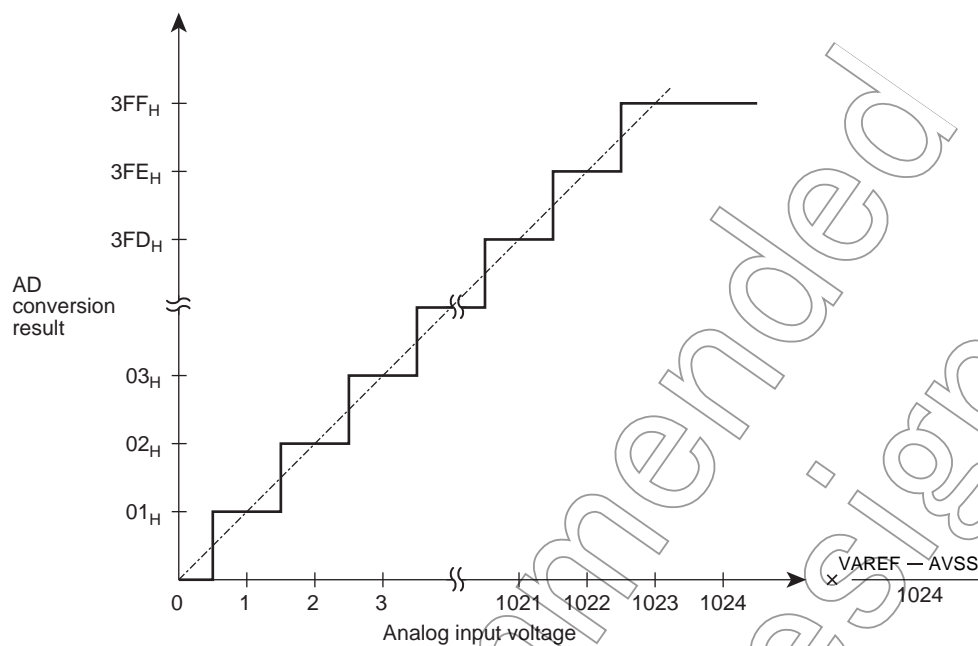

Figure 16-4 Analog Input Voltage and AD Conversion Result (Typ.)

Not Recommended for New Design

## 16.6 Precautions about AD Converter

### 16.6.1 Analog input pin voltage range

Make sure the analog input pins (AIN0 to AIN15) are used at voltages within VAREF to AVSS. If any voltage outside this range is applied to one of the analog input pins, the converted value on that pin becomes uncertain. The other analog input pins also are affected by that.

### 16.6.2 Analog input shared pins

The analog input pins (AIN0 to AIN15) are shared with input/output ports. When using any of the analog inputs to execute AD conversion, do not execute input/output instructions for all other ports. This is necessary to prevent the accuracy of AD conversion from degrading. Not only these analog input shared pins, some other pins may also be affected by noise arising from input/output to and from adjacent pins.

### 16.6.3 Noise Countermeasure

The internal equivalent circuit of the analog input pins is shown in Figure 16-5. The higher the output impedance of the analog input source, more easily they are susceptible to noise. Therefore, make sure the output impedance of the signal source in your design is 5 kΩ or less. Toshiba also recommends attaching a capacitor external to the chip.

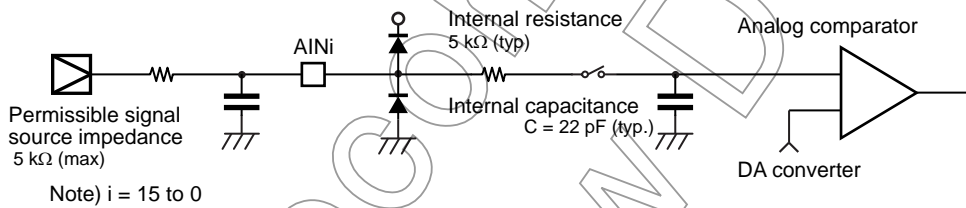

Figure 16-5 Analog Input Equivalent Circuit and Example of Input Pin Processing

Not Recommended  
for New Design

## 17. 8-Bit High-speed PWM (HPWM0 and HPWM1)

The TMP88CS42NG contains two-channels of high-speed PWM. The high-speed PWM works in such a way that when data are written to the data registers for the respective channels, waveforms differing from each other can be output.

The high-speed PWM is shared with ports, P02 (HPWM0) and P03 (HPWM1). When using these pins for high-speed PWM, set the port output latches for P02 and P03 to 1.

### 17.1 Configuration

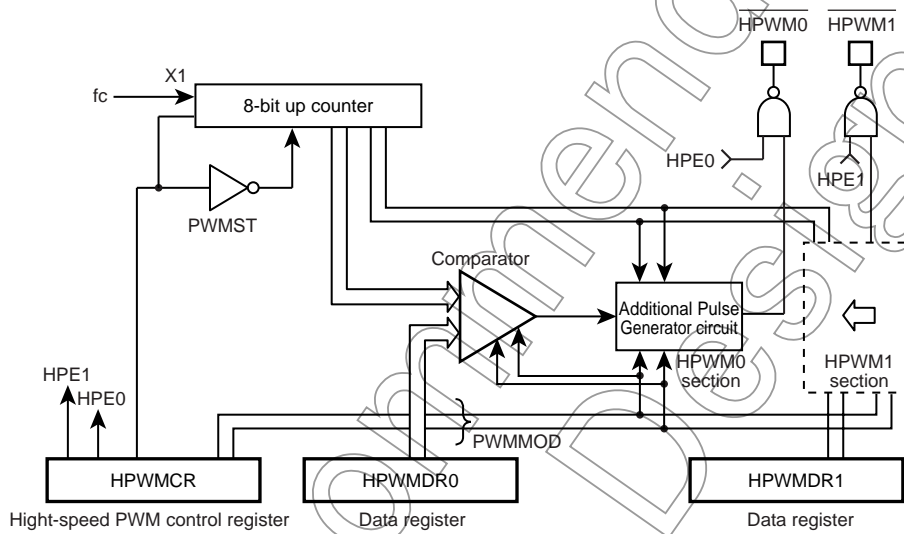

Figure 17-1 High-speed PWM (HPWM0 and HPWM1)

Not Rec for New

## 17.2 Control

### Control Register

HPWMCR (000CH)	7	6	5	4	3	2	1	0	
	HPE1	HPE0			PWMST			PWMMOD	R/W (Initial value: 00** 0*00)

PWMMOD	Select PWM mode	00: Mode 0 (8 bits) 01: Mode 1 (7 bits) 10: Mode 2 (6 bits) 11: Reserved	R/W
PWMST	Run/stop 8-bit up counter	0: STOP 1: RUN	
HPE0	Control HPWM0 output	0: Disable 1: Enable	
HPE1	Control HPWM1 output	0: Disable 1: Enable	

### Data Register

HPWMDR0 (000DH)	7	6	5	4	3	2	1	0	
	DATA7	DATA6	DATA5	DATA4	DATA3	DATA2	DATA1	DATA0	R/W (Initial value: **** *)
HPWMDR1 (000EH)	7	6	5	4	3	2	1	0	
	DATA7	DATA6	DATA5	DATA4	DATA3	DATA2	DATA1	DATA0	R/W (Initial value: **** *)

Note 1: The PWM output pulse width varies with the clock duty cycle.

Note 2: For the data registers, set data 10H to F0H.

Note 3: When HPWMCR<PWMST> = 0, the internal counter is cleared and data "1" is output to the port.

Note 4: Before selecting PWM mode, make sure HPWMCR<PWMST> = 0.

Note 5: Before entering STOP mode, set HPWMCR<PWMST, HPE0, and HPE1> all to 0.

Note 6: If HPWMCR<HPE0 or HPE1> is altered in the middle of PWM period, the waveform may be distorted. To avoid waveform distortion, make sure HPWMCR<PWMST> = 0 when enabling HPWM output.

## 17.3 Functional Description

The high-speed PWM is controlled using the Control Register (HPWMCR) and Data Registers (HPWMDR0, 1). Before writing to these registers, set the HPWMCR<PWMST> = 1 to make them ready for setup. When the HPWMCR<PWMST> is set to 0, each control register is reset, so that the high-speed PWM can be reset in software.

### 17.3.1 Operation modes

The high-speed PWM has the following three modes of operation:

- 8-bit mode: ( $T = 2^8 \times \text{clock period}$ ,  $f \approx 78 \text{ kHz}$ )
- 7-bit mode: ( $T = 2^7 \times \text{clock period}$ ,  $f \approx 156 \text{ kHz}$ )
- 6-bit mode: ( $T = 2^6 \times \text{clock period}$ ,  $f \approx 313 \text{ kHz}$ )

Note: These values apply to the case where the source clock (X1) is 20 MHz.

Use the HPWMCR<PWMMOD> to select operation mode. Note that operation mode is common to both channels, and cannot be set separately for each channel.

17.3.1.1 8-bit mode

In 8-bit mode, it is possible to generate a pulse with 12.8 μs period and approximately 78 kHz frequency (when X1 = 20 MHz).

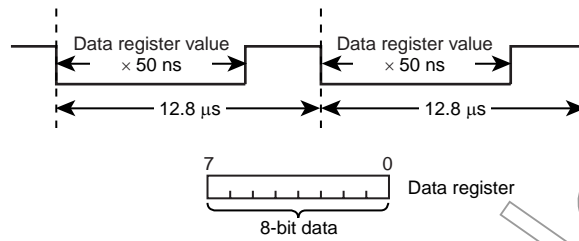

The minimum width of the pulse is 0.8 μs (data “10”), and the maximum width of the pulse is 12.0 μs (data “F0”).

$$\text{Pulse width} = 8\text{-bit data} \times 50 \text{ ns}$$

Figure 17-2 shows a typical waveform in 8-bit mode. (The values are for X1 = 20 MHz.)

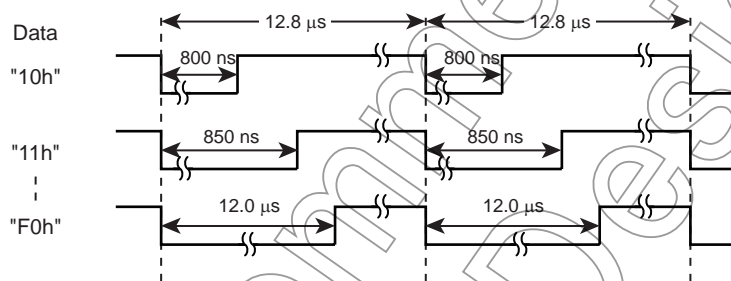
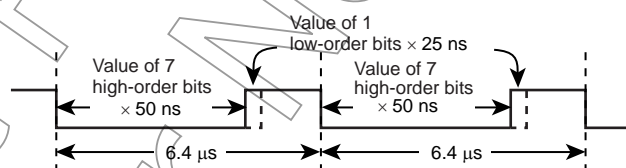

Figure 17-2 8-Bit Mode

17.3.1.2 7-bit mode

In 7-bit mode, it is possible to generate a pulse with 6.4 μs period and approximately 156 kHz frequency (when X1 = 20 MHz).



In 7-bit mode, the period is comprised of 7 bits (period =  $2^7 \times 50 \text{ ns}$ ) and one other bit provides a 25 ns resolution (half period of the source clock (X1)). Therefore, when the one low-order bit = 1, a plus-25 ns pulse is output.

The minimum width of the pulse is 0.4 μs (data “10”), and the maximum width of the pulse is 6.0 μs (data “F0”: “78” + “0”).

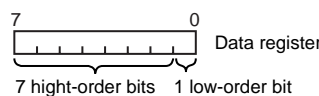

$$\text{Pulse width} = (7 \text{ high-order Bits of data} \times 50 \text{ ns}) + (1 \text{ low-order Bit of data} \times 25 \text{ ns})$$

Figure 17-3 shows a typical waveform in 7-bit mode. (The values are for X1 = 20 MHz.)

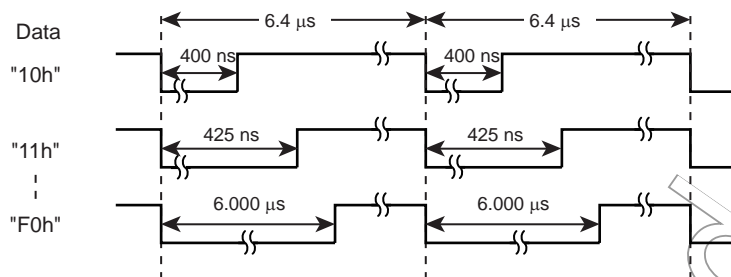
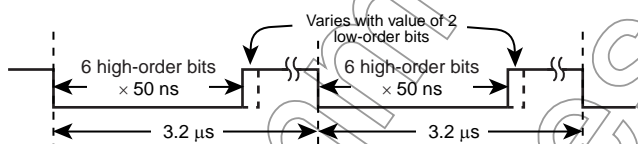

Figure 17-3 7-Bit Mode

Note: The resolution of the LSB 1 bit (25 nsec) is a typical value and its precision is not guaranteed.

### 17.3.1.3 6-bit mode

In 6-bit mode, it is possible to generate a pulse with 3.2 μs period and approximately 313 kHz frequency (when X1 = 20 MHz).



In 6-bit mode, the period is comprised of 6 bits (period =  $2^6 \times 50$  ns) and two other bits provide a 12.5 ns resolution. However, because the actually obtained resolution is 25 ns, said resolution is accomplished artificially. To obtain a 12.5 ns resolution, the first, second, and third pulses are output by adding 25 ns, 0 ns, and 25 ns, respectively. In this way, a 12.5 ns resolution is realized as being “equivalent to.”

The minimum equivalent width of the pulse is 0.2 μs (data “10”), and the maximum equivalent width of the pulse is 3.0 μs (data “F0”: “3B” + “0”).

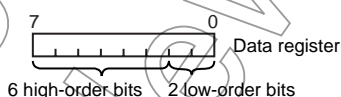

$$\text{Pulse width} = (6 \text{ high-order bits of data} \times 50 \text{ ns}) + (2 \text{ low-order bits of data} \times \text{resolution})$$

\* The equivalent plus times in 2 low-order bits of data are shown below.

2-bit data	Equivalent plus time
0 0	0 ns
0 1	12.5 ns
1 0	25 ns
1 1	37.5 ns

Figure 17-4 Shows a typical waveform in 6-bit mode. (The values are for X1 = 20 MHz.)

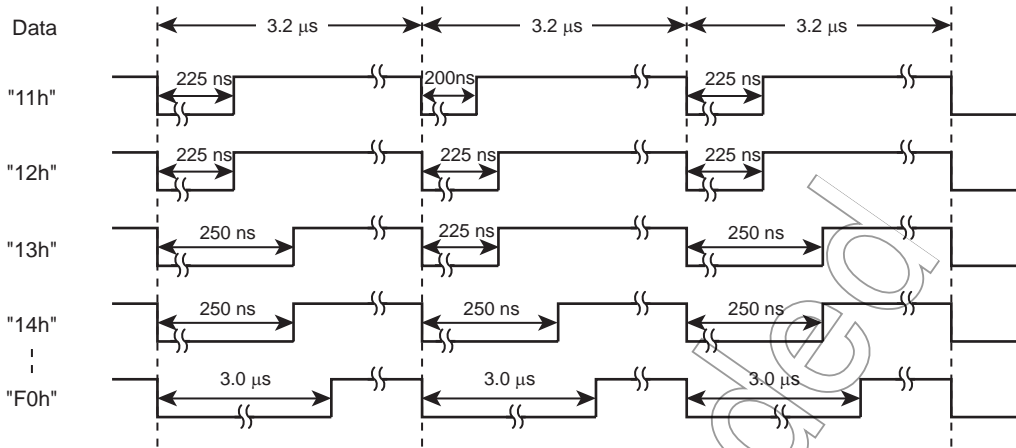

Figure 17-4 6-Bit Mode

Note: The resolution of the LSB 2 bit (12.5 nsec) is a typical value and its precision is not guaranteed.

### 17.3.2 Setting output data

To set output data, write it to the Data Registers (HPWMDR0 and 1).

Example: To output a 5.75 μs waveform in 7-bit mode using HPWM0 when the source clock (X1) = 20 MHz



Because the resolution in 7-bit mode is 50 ns, to output a 5.75 μs pulse

$$5.75 \mu\text{s} \div 50 \text{ ns} = 115 = 73\text{H}$$

Because 73H is placed in the 7 high-order bits, the value is shifted one bit to become E6H. Therefore, set E6H in the Data Register (HPWMDR0).

Not for New Commercial Design



Not Recommended  
for New Design

# 18. Input/Output Circuitry

## 18.1 Control pins

The input/output circuitries of the TMP88CS42NG control pins are shown below.

Control Pin	I/O	Input/Output Circuitry	Remark
XIN XOUT	Input Output		High-frequency resonator connecting pins $R_f = 1.2 \text{ M}\Omega$ (typ.) $R_o = 0.5 \text{ k}\Omega$ (typ.)
$\overline{\text{RESET}}$	Input		Hysteresis input Pull-up resistor included $R_{IN} = 220 \text{ k}\Omega$ (typ.)
TEST	Input		Pull-down resistor included $R_{IN} = 70 \text{ k}\Omega$ (typ.) Fix the TEST pin at "L" level in MCU mode.

Note: The TEST pin of TMP88PS42 does not have a pull-down resistor ( $R_{IN}$ ) and protect diode (D1).  
 Fix the TEST pin at "L" level in MCU mode.

## 18.2 Input/output ports

Port	Type	Input/output Circuit	Remark
P0 P3 P4 P5	I/O	<p>Initial "High-Z"</p>	<p>Tri-state output                      Programmable open-drain                      P3, P4, P5: Large-current port                      Hysteresis input</p>
P6 P7	I/O	<p>Initial "High-Z"</p>	<p>Tri-state output</p>
P1	I/O	<p>Initial "High-Z"</p>	<p>Tri-state output                      Hysteresis input</p>
P2	I/O	<p>Initial "High-Z"</p>	<p>Open-drain output                      Hysteresis input</p>

Not for New

## 19. Electrical Characteristics

### 19.1 Absolute Maximum Ratings

The Absolute Maximum Ratings stipulate the standards, any parameter of which cannot be exceeded even in an instant. If the device is used under conditions exceeding the Absolute Maximum Ratings, it may break down or degrade, causing injury due to rupture or burning. Therefore, always make sure the Absolute Maximum Ratings will not be exceeded when designing your application equipment.

( $V_{SS} = 0\text{ V}$ )

Parameter	Symbol	Pins	Standard	Unit	Remark
Power supply voltage	$V_{DD}$		-0.3 to 6.5		
Input voltage	$V_{IN}$		-0.3 to $V_{DD} + 0.3$	V	
Output voltage	$V_{OUT}$		-0.3 to $V_{DD} + 0.3$		
Output current	$I_{OH}$	P0, P1, P3, P4, P5, P6, P7	-1.8		
	$I_{OL1}$	P0, P1, P2, P6, P7	3.2		
	$I_{OL2}$	P3, P4, P5	30		
Mean output current	$\Sigma I_{OUT1}$	P0, P1, P2, P6, P7	60	mA	Total of all ports except large-current ports
	$\Sigma I_{OUT2}$	P3	60		Total of 8 pins of large-current ports P30 to 7
	$\Sigma I_{OUT3}$	P4	60		Total of 8 pins of large-current ports P40 to 7
	$\Sigma I_{OUT4}$	P5	60		Total of 8 pins of large-current ports P50 to 7
Power dissipation	$P_D$	TMP88CS42NG	600	mW	SDIP
Operating temperature	$T_{opr}$		-40 to 85	°C	
Soldering temperature (time)	$T_{sld}$		260 (10 s)		
Storage temperature	$T_{stg}$		-55 to 125		

## 19.2 Operating Conditions

The Operating Conditions show the conditions under which the device be used in order for it to operate normally while maintaining its quality. If the device is used outside the range of Operating Conditions (power supply voltage, operating temperature range, or AC/DC rated values), it may operate erratically. Therefore, when designing your application equipment, always make sure its intended working conditions will not exceed the range of Operating Conditions.

( $V_{SS} = 0\text{ V}$ ,  $T_{opr} = -40\text{ to }85^\circ\text{C}$ )

Parameter	Symbol	Pins	Condition	Min	Max	Unit
Power supply voltage	$V_{DD}$		$f_c = 20\text{ MHz}$ NORMAL/IDLE/STOP	4.5	5.5	V
High level input voltage	$V_{IH1}$	Normal (P6, P7)	$V_{DD} \geq 4.5\text{ V}$	$V_{DD} \times 0.70$	$V_{DD}$	V
	$V_{IH2}$	Hysteresis (P0, P1, P2, P3, P4, P5, $\overline{\text{RESET}}$ )		$V_{DD} \times 0.75$		
Low level input voltage	$V_{IL1}$	Normal (P6, P7)	$V_{DD} \geq 4.5\text{ V}$	0	$V_{DD} \times 0.30$	
	$V_{IL2}$	Hysteresis (P0, P1, P2, P3, P4, P5, $\overline{\text{RESET}}$ )		$V_{DD} \times 0.25$		
Clock frequency	$f_c$	XIN, XOUT	$V_{DD} = 4.5\text{ V to }5.5\text{ V}$	8	20	MHz

## 19.3 DC Characteristics

( $V_{SS} = 0\text{ V}$ ,  $T_{opr} = -40\text{ to }85^\circ\text{C}$ )

Parameter	Symbol	Pins	Condition	Min	Typ.	Max	Unit
Input current	$I_{IN1}$	TEST	$V_{DD} = 5.5\text{ V}$ , $V_{IN} = 5.5\text{ V}/0\text{ V}$	-	-	$\pm 2$	$\mu\text{A}$
	$I_{IN2}$	Sink open drain, Tri-state					
	$I_{IN3}$	$\overline{\text{RESET}}$ , $\overline{\text{STOP}}$					
Input Resistance	$R_{IN1}$	TEST		-	70	-	$\text{k}\Omega$
	$R_{IN2}$	$\overline{\text{RESET}}$		90	220	510	
Output leakage current	$I_{LO}$	Sink open drain, Tri-state	$V_{DD} = 5.5\text{ V}$ , $V_{IN} = 5.5\text{ V}/0\text{ V}$	-	-	$\pm 2$	$\mu\text{A}$
High level output voltage	$V_{OH}$	Tri-state port	$V_{DD} = 4.5\text{ V}$ , $I_{OH} = -0.7\text{ mA}$	4.1	-	-	V
Low level output voltage	$I_{OL1}$	P0, P1, P2, P6, P7	$V_{DD} = 4.5\text{ V}$ , $V_{OL} = 0.4\text{ V}$	1.6	-	-	mA
	$I_{OL2}$	P3, P4, P5	$V_{DD} = 4.5\text{ V}$ , $V_{OL} = 1.0\text{ V}$	-	20	-	
NORMAL mode power supply current	$I_{DD}$		$V_{DD} = 5.5\text{ V}$ , $V_{IN} = 5.3\text{ V}/0.2\text{ V}$ $f_c = 20\text{ MHz}$	-	18	25	
IDLE mode power supply current				-	16	23	
STOP mode power supply current				-	2	100	$\mu\text{A}$

Note 1: Typical values show those at  $T_{opr} = 25^\circ\text{C}$ ,  $V_{DD} = 5\text{ V}$ .

Note 2: Input current ( $I_{IN1}$ ,  $I_{IN3}$ ): The current through pull-up or pull-down resistor is not included.

Note 3:  $I_{DD}$  does not include  $I_{REF}$  current.

### 19.4 AD Conversion Characteristics

(Topr = -40 to 85°C)

Parameter	Symbol	Condition	Min	Typ.	Max		Unit
					8 bit	10 bit	
Analog reference voltage	$V_{AREF}$	$V_{SS} = 0\text{ V}, V_{DD} = AV_{DD}$	$V_{DD} - 1.0$	-	$V_{DD}$		V
Analog input voltage range	$V_{AIN}$		$V_{ASS}$	-	$V_{AREF}$		
Analog reference power supply current	$I_{REF}$	$V_{DD} = AV_{DD} = V_{AREF} = 5.0\text{ V}$ $V_{SS} = AV_{SS} = 0\text{ V}$	-	0.5	1.0		mA
Nonlinearity error		$V_{DD} = 5\text{ V}, V_{SS} = 0\text{ V}$ $AV_{DD} = V_{AREF} = 5\text{ V}$ $AV_{SS} = 0\text{ V}$	-	-	$\pm 1$	$\pm 2$	LSB
Zero error			-	-	$\pm 1$	$\pm 2$	
Full scale error			-	-	$\pm 1$	$\pm 2$	
Overall error			-	-	$\pm 2$	$\pm 4$	

Note 1: The total error includes all errors except a quantization error, and is defined as a maximum deviation from the idea conversion line.

Note 2: Conversion time is different in recommended value by power supply voltage. About conversion time, please refer to "Register Configuration" in the section of AD converter.

Note 3: Please use input voltage to AIN input pin in limit of  $V_{AREF} - V_{SS}$ . When voltage or range outside is input, conversion value becomes unsettled and gives affect to other channel conversion value.

Note 4: Analog reference voltage range;  $\Delta V_{AREF} = V_{AREF} - V_{SS}$

### 19.5 AC Characteristics

( $V_{SS} = 0\text{ V}, V_{DD} = 4.5\text{ to }5.5\text{ V}, \text{Topr} = -40\text{ to }85^\circ\text{C}$ )

Parameter	Symbol	Condition	Min	Typ.	Max	Unit
Machine cycle time	$t_{CY}$	During NORMAL mode	0.2	-	0.5	$\mu\text{s}$
		During IDLE mode				
High level clock pulse width	$t_{WCH}$	When operating with external clock (XIN input) $f_c = 20\text{ MHz}$	-	25	-	ns
Low level clock pulse width	$t_{WCL}$					

## 19.6 Recommended Oscillation Conditions

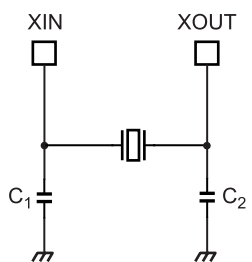

High-frequency oscillation

Note 1: To ensure stable oscillation, the resonator position, load capacitance, etc. must be appropriate. Because these factors are greatly affected by board patterns, please be sure to evaluate operation on the board on which the device will actually be mounted.

Note 2: For the resonators to be used with Toshiba microcontrollers, we recommend ceramic resonators manufactured by Murata Manufacturing Co., Ltd.

For details, please visit the website of Murata at the following URL:  
<http://www.murata.com>

## 19.7 Handling Precaution

- The solderability test conditions for lead-free products (indicated by the suffix G in product name) are shown below.

1. When using the Sn-37Pb solder bath  
Solder bath temperature = 230 °C  
Dipping time = 5 seconds  
Number of times = once  
R-type flux used
2. When using the Sn-3.0Ag-0.5Cu solder bath  
Solder bath temperature = 245 °C  
Dipping time = 5 seconds  
Number of times = once  
R-type flux used

Note: The pass criterion of the above test is as follows:

Solderability rate until forming  $\geq 95$  %

- When using the device (oscillator) in places exposed to high electric fields such as cathode-ray tubes, we recommend electrically shielding the package in order to maintain normal operating condition.

# 20. Package Dimensions

SDIP64-P-750-1.78 Rev 01

Unit: mm

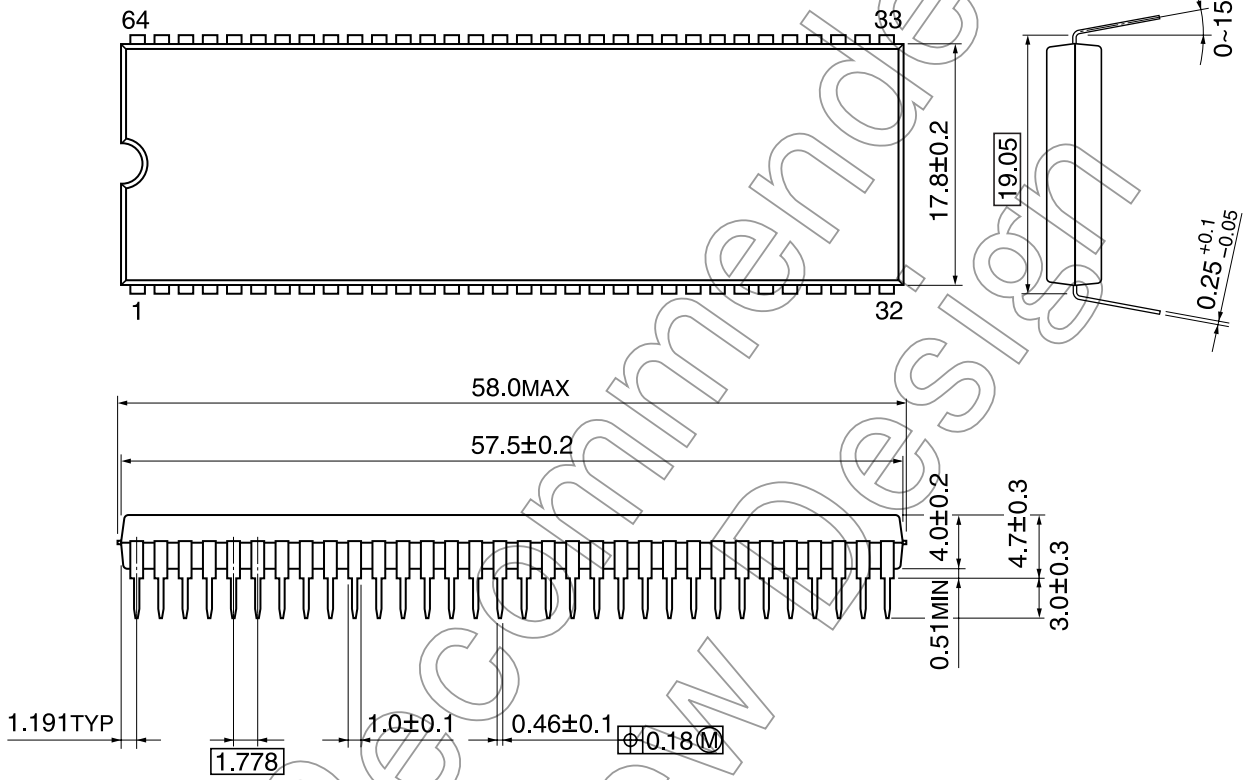

Not Recommended for New Design



Not Recommended  
for New Design

This is a technical document that describes the operating functions and electrical specifications of the 8-bit microcontroller series TLCS-870/X (LSI).

Toshiba provides a variety of development tools and basic software to enable efficient software development.

These development tools have specifications that support advances in microcomputer hardware (LSI) and can be used extensively. Both the hardware and software are supported continuously with version updates.

The recent advances in CMOS LSI production technology have been phenomenal and microcomputer systems for LSI design are constantly being improved. The products described in this document may also be revised in the future. Be sure to check the latest specifications before using.

Toshiba is developing highly integrated, high-performance microcomputers using advanced MOS production technology and especially well proven CMOS technology.

We are prepared to meet the requests for custom packaging for a variety of application areas.

We are confident that our products can satisfy your application needs now and in the future.

Not Recommended  
for New Design

Not Recommended  
for New Design