



Integrated Power Supply for TFT-LCD Panels with 4-Channel White LED Driver

Features

- 2.5V to 5.5V Input Supply Range
- Boost Regulator
 - ◆ 640kHz/1.2MHz Fixed Frequency
 - ◆ Current-Mode Control
 - ◆ Fast Transient Response to Pulse Load
 - ◆ $\pm 1\%$ Accurate Output Voltage
 - ◆ Built-In 20V/2A, 0.2 Ω N-Channel MOSFET
 - ◆ High Efficiency up to 90%
 - ◆ Programmable Soft-Start
 - ◆ Over-Current Protection
 - ◆ Output Under-Voltage Protection
- White-LED Driver
 - ◆ Wide 4.2V to 24V Input Supply Range
 - ◆ Adjustable Switching Frequency
 - ◆ 40V/2A, 0.3 Ω n-channel MOSFET
 - ◆ Input Under-Voltage Protection
 - ◆ Over Current Protection
 - ◆ Over Voltage Protection
 - ◆ Maximum Programmable LED Channel Current 50mA
 - ◆ Maximum 3% Matching between Channels
 - ◆ 100Hz~20kHz PWM Dimming
- High-Performance Operational Amplifiers
 - ◆ $\pm 150\text{mA}$ Output Short-Circuit Current
 - ◆ 12V/ μs Slew Rate
 - ◆ 12MHz, -3dB Bandwidth
 - ◆ Rail-to-Rail Input and Output
- Low Dropout Voltage Linear Regulator
 - ◆ 350mA Maximum Output Current
 - ◆ Adjustable Output Voltage
- On-Chip GPM Controller
 - ◆ Adjustable Falling Time and Power-On Delay
 - ◆ Flicker Compensator
 - ◆ Power-On Sequence Control
- Charge pump for VGH regulation
- Low Voltage Detector
 - ◆ Programmable Detecting Voltage and Delay Time
- Thermal Protection
- RoHs Compliant
- TQFN5X5-40 and TQFN3.8X6.2-44 Package

Applications

- Notebook Computer Displays
- UMPCs
- LCD Monitor

General Description

The G5524A includes a high-performance boost regulator, 4-channel LED driver, a low dropout linear regulator (LDO), a gate pulse modulator (GPM), a voltage detector, a VCOM buffer (unity-gain OPA), and a VGH charge pump controller for active-matrix thin-film transistor (TFT) liquid-crystal displays (LCDs).

The boost converter provides the regulated supply voltage for the panel source driver ICs. The converter is a high switching frequency (640kHz or 1.2MHz) current-mode regulator with an integrated 20V N-Channel 0.2 Ω MOSFET that allows the use of ultra-small inductors and ceramic capacitors. It provides fast transient response to pulsed loading while achieving efficiency over 90%. The device can produce output voltage as high as 18V from an input as low as 2.8V. Soft-Start is programmed by external capacitor, which sets the input-current ramp-rate.

The LED driver automatically regulated supply voltage for the LED light bars without the need to calculate the output for different LED types. A FREQ2 pin is applied to adjust switching frequency in the range of 640kHz to 2MHz. It also integrates a 40V n-channel MOSFET that provides high output power. The 4-channel current driver is ideal for constant current driving, and, well matched less than 3%. To set the maximum driving current, the ISET pin is used to determine reference current. Each channel of the current drivers is set to 1300 times of this reference current. A PWM pin can be used to perform PWM dimming from the range of 100Hz to 20kHz. Open LED-string automatically disable the channel from entering over voltage protection.

The low-dropout (LDO) linear regulator can supply up to 350mA current while input voltage is 3.3V. It uses an internal PMOS as the pass device. It is suitable for the supply voltage of the timing controller.

The GPM is controlled by frame signals from timing controller to modulate the Gate-On voltage, VGHM, which acts a flicker compensation circuit to reduce the coupling effect between gate lines and pixels. It also can delay the Gate-On voltage while power-on for achieving a corrected power-on sequence for gate driver ICs. Both of power-on delay time and the falling time of the Gate-On voltage are programmable by external capacitor and resistor.

The voltage detector monitors the supply voltage to issue a reset signal while the detected voltage is too low. The detecting level is decided by an external resistor divider and the delay time is programmable by an external capacitor.

The VCOM buffer can drive the LCD VCOM voltage that features high short-circuit current (150mA), fast slew rate (12V/ μs), wide bandwidth (12MHz) and rail-to-rail input/output.

The VGH charge pump controller provides regulated TFT Gate-On voltage. The regulation of the positive charge pump is generated by the internal comparator that senses the output voltage and compares it with an internal reference.

Ordering Information

ORDER NUMBER	MARKING	TEMP. RANGE	PACKAGE (Green)
G5524ARG1U	5524	-40°C to 85°C	TQFN5X5-40
G5524AK41U	5524	-40°C to 85°C	TQFN3.8X6.2-44

Note: RG: TQFN5X5-40 K4: TQFN3.8X6.2-44

1: Bonding Code
U: Tape & Reel

Pin Configuration

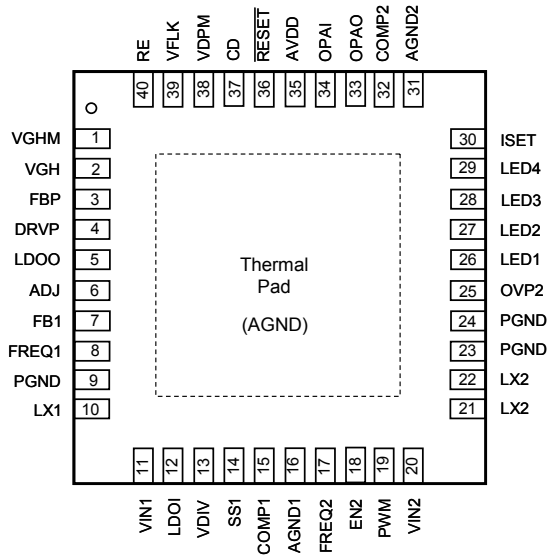

G5524A TQFN5X5-40

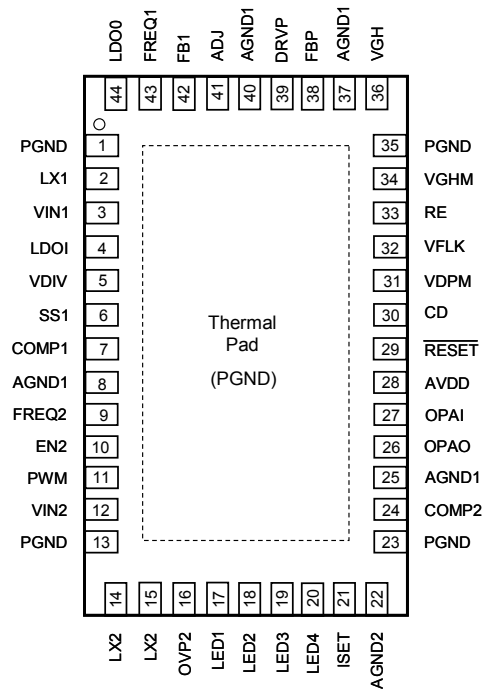

G5524A TQFN3.8X6.2-44

Note: Recommend connecting the Thermal Pad to the Ground for excellent power dissipation.