

US1001FL THRU US1008FL



1 Amp Ultra Fast Recovery

Features

- Low Cost
- Ultra fast Recovery
- High Reliability
- Case Material: Molded Plastic. UL Flammability Classification Rating 94V-0 and MSL Rating 1

Maximum Ratings

- Operating Temperature: -65°C to +150°C
- Storage Temperature: -65°C to +150°C
- Maximum Thermal Resistance; 180°C/W Junction To Ambient.

MCC Part Number	Device Marking	Maximum Recurrent Peak Reverse Voltage	Maximum RMS Voltage	Maximum DC Blocking Voltage
US1001FL	U1	50V	35V	50V
US1002FL	U2	100V	70V	100V
US1003FL	U3	200V	140V	200V
US1004FL	U4	400V	280V	400V
US1006FL	U5	600V	420V	600V
US1007FL	U6	800V	560V	800V
US1008FL	U7	1000V	700V	1000V

Electrical Characteristics @ 25°C Unless Otherwise Specified

Average Forward Current	$I_{F(AV)}$	1.0A	$T_L = 90^\circ\text{C}$
Peak Forward Surge Current	I_{FSM}	30A	8.3ms, half sine
Maximum Instantaneous Forward Voltage US1001FL-03FL US1004FL US1006FL-08L	V_F	1.0V 1.40V 1.70V	$I_{FM} = 1.0A;$ $T_a = 25^\circ\text{C}$
Maximum DC Reverse Current At Rated DC Blocking Voltage	I_R	2 μA 20 μA	$T_a = 25^\circ\text{C}$ $T_a = 125^\circ\text{C}$
Maximum Reverse Recovery Time US1001L-03FL US1004FL US1006L-07L US1008FL	T_{rr}	35ns 50ns 75ns 100ns	$I_F = 0.5A, I_R = 1.0A,$ $T_{rr} = 0.25A$
Typical Junction Capacitance	C_J	20pF	Measured at 1.0MHz, $V_R = 4.0V$

Recovery Silicon Rectifier 50 to 1000 Volts

SOD-123FL

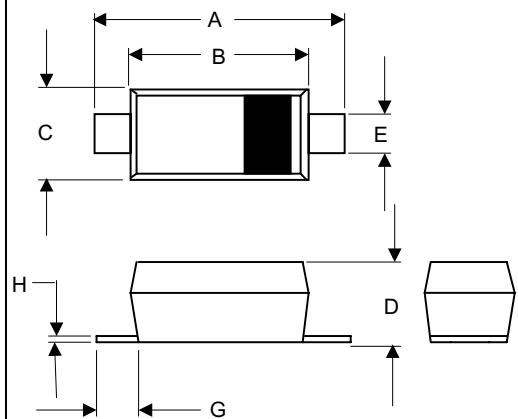

DIM	DIMENSIONS				NOTE
	INCHES		MM		
A	.140	.152	3.55	3.85	
B	.100	.112	2.55	2.85	
C	.055	.071	1.40	1.80	
D	.037	.053	0.95	1.35	
E	.020	.039	0.50	1.00	
G	.010	-----	0.25	-----	
H	-----	.008	-----	.20	

SUGGESTED SOLDER PAD LAYOUT

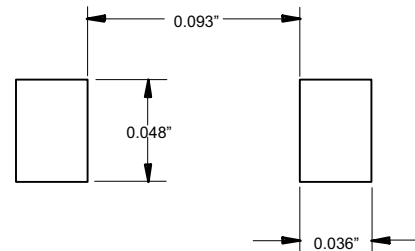

US1001FL THRU US1008FL

Figure 1
Typical Forward Characteristics

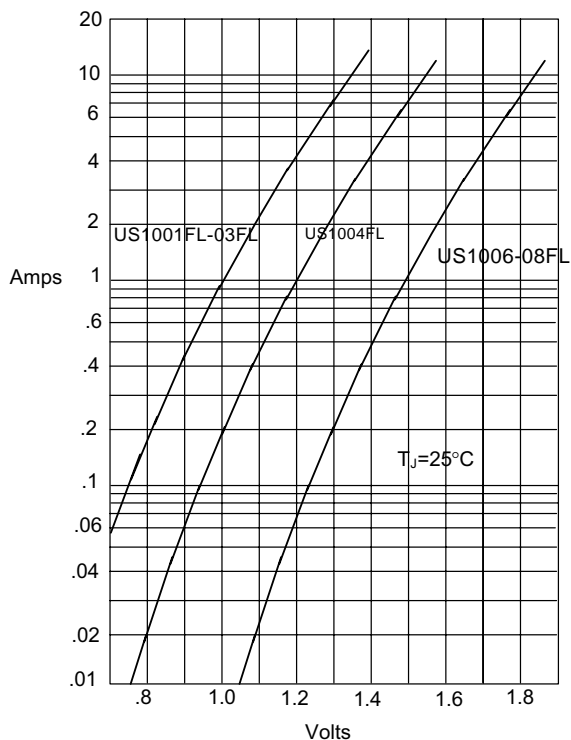

Instantaneous Forward Current - Amperes versus
Instantaneous Forward Voltage - Volts

Figure 2
Forward Derating Curve

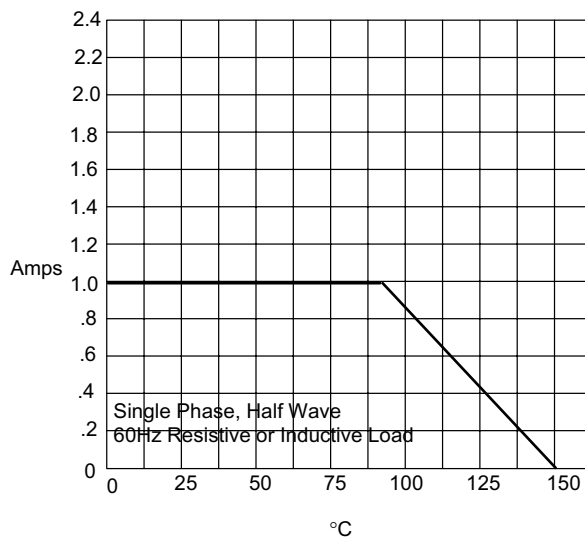

Average Forward Rectified Current - Amperes versus
Lead Temperature - $^\circ\text{C}$

Figure 3
Junction Capacitance

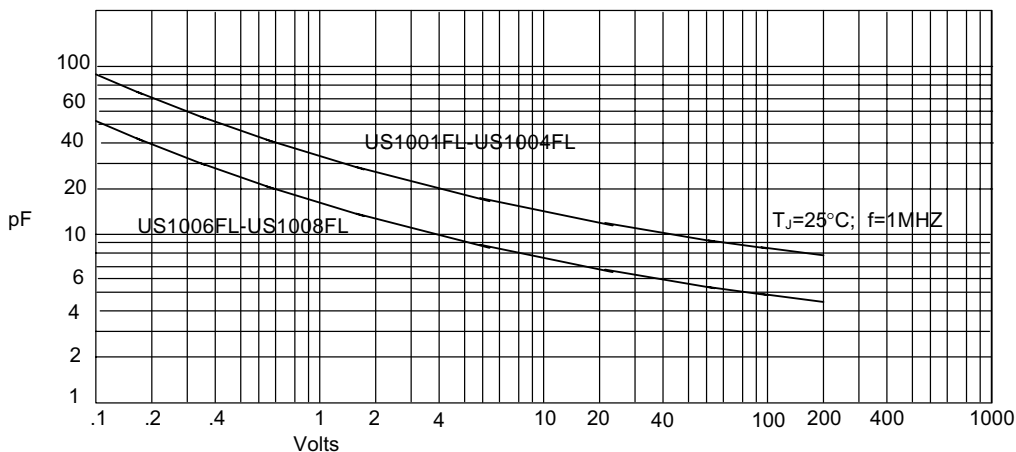

Junction Capacitance - pF versus
Reverse Voltage - Volts

Figure 4
Peak Forward Surge Current

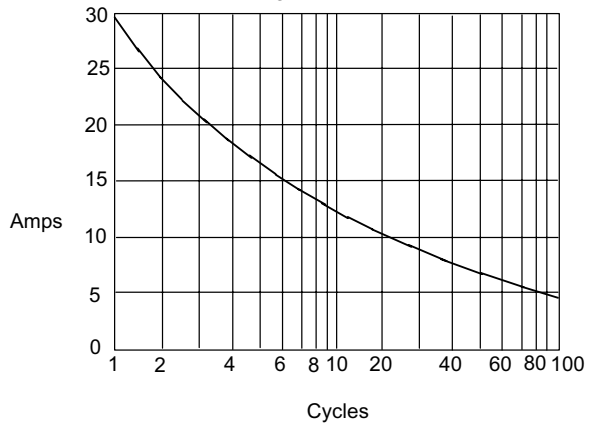

Peak Forward Surge Current - Amperes *versus*
Number Of Cycles At 60Hz - Cycles

Figure 5
Reverse Recovery Time Characteristic And Test Circuit Diagram

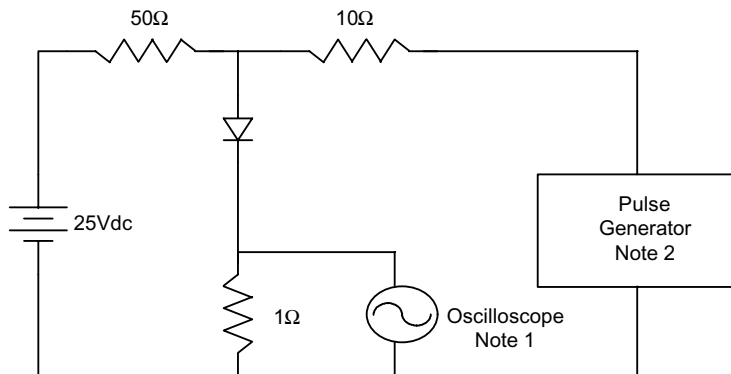

- Notes:
1. Rise Time = 7ns max.
Input impedance = 1 megohm, 22pF
 2. Rise Time = 10ns max.
 3. Source impedance = 50 ohms
 3. Resistors are non-inductive

