

### Isolated, Fixed-Ratio DC-DC Converter

#### Features & Benefits

- Up to 125A continuous low voltage side current
- Fixed transformation ratio(K) of 1/32
- Up to 711 W/in<sup>3</sup> power density
- 97.1% peak efficiency
- Built-in EMI filtering and In-rush limiting circuit
- Parallel operation for multi-kW arrays
- OV, OC, UV, short circuit and thermal protection
- 4414 package
- High MTBF
- Thermally enhanced VIA<sup>™</sup> package
- PMBus<sup>™</sup> management interface
- Suitable for hot-swap applications

#### Typical Applications

- 380V<sub>DC</sub> Power Distribution
- Information and Communication Technology (ICT) Equipment
- High End Computing Systems
- Automated Test Equipment
- Industrial Systems
- High Density Energy Systems
- Transportation
- Green Buildings and Microgrids

#### Part Ordering Information

Product Function	Package Length	Package Width	Package Type	Max High Side Voltage	High Side Voltage Range Ratio	Max Low Side Voltage	Max Low Side Current	Product Grade (Case Temperature)	Option Field
BCM	44	14	x	D1	E	13	A2	y	zz
BCM = Bus Converter Module	Length in Inches x 10	Width in Inches x 10	B = Board VIA V = Chassis VIA	Internal Reference				C = -20 to 100°C <sup>[1]</sup> T = -40 to 100°C <sup>[1]</sup>	02 = Chassis/PMBus 06 = Short Pin/PMBus 10 = Long Pin/PMBus

<sup>[1]</sup> High Temperature Current Derating may apply; See Figure 1, specified thermal operating area.

Product Ratings	
V <sub>HI</sub> = 384V (260 – 410V)	I <sub>LO</sub> = up to 125A
V <sub>LO</sub> = 12V (8.1 – 12.8V) (NO LOAD)	K = 1/32

#### Product Description

The BCM in a VIA package is a high efficiency Bus Converter, operating from a 260 to 410V<sub>DC</sub> high voltage bus to deliver an isolated 8.1 to 12.8V<sub>DC</sub> unregulated, low voltage.

This unique ultra-low profile module incorporates DC-DC conversion, integrated filtering and PMBus<sup>™</sup> commands and controls in a chassis or PCB mount form factor.

The BCM offers low noise, fast transient response and industry leading efficiency and power density. A low voltage side referenced PMBus<sup>™</sup> compatible telemetry and control interface provides access to the BCM's internal controller configuration, fault monitoring, and other telemetry functions.

Leveraging the thermal and density benefits of Vicor's VIA packaging technology, the BCM module offers flexible thermal management options with very low top and bottom side thermal impedances.

When combined with downstream Vicor DC-DC conversion components and regulators, the BCM allows the Power Design Engineer to employ a simple, low-profile design which will differentiate the end system without compromising on cost or performance metrics.



Size:  
4.35 x 1.40 x 0.37 in  
110.55 x 35.54 x 9.40mm

Typical Application

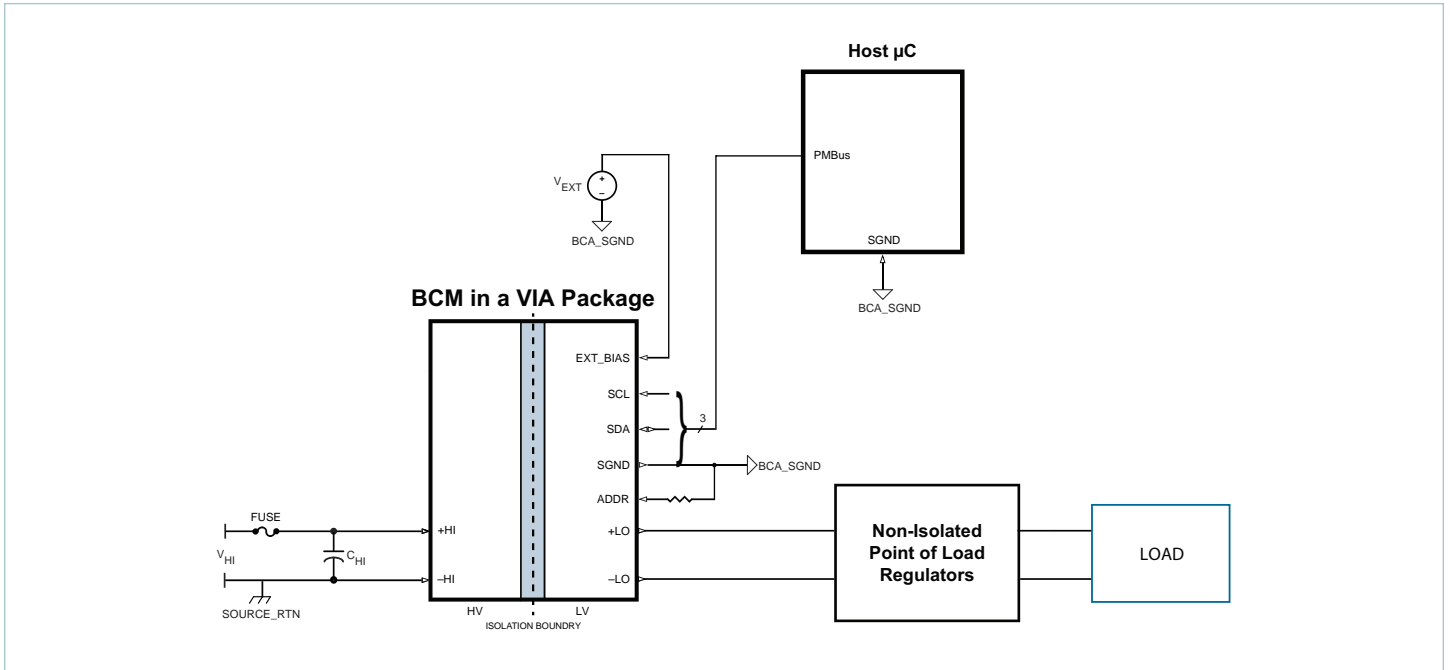

BCM4414xD1E13A2yzz at point of load

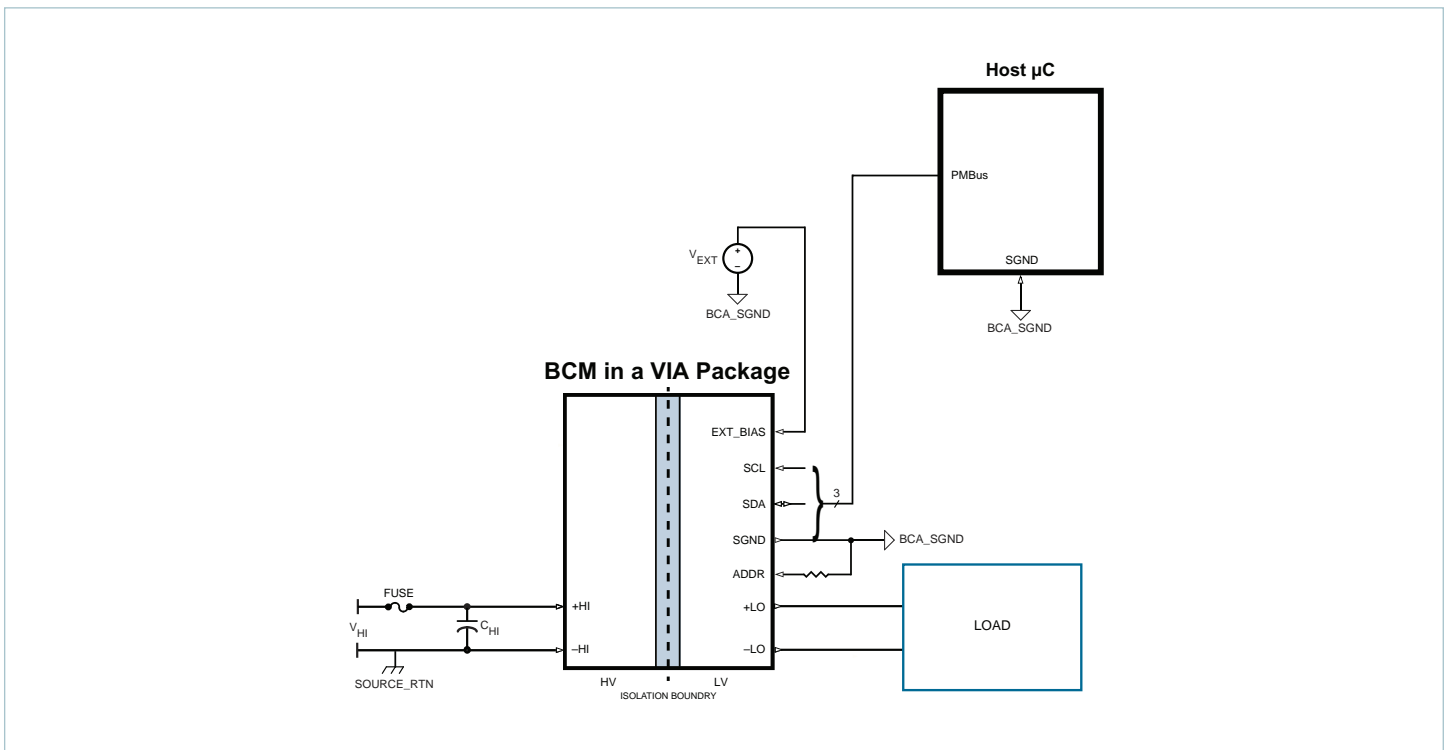

BCM4414xD1E13A2yzz direct to load

Pin Configuration

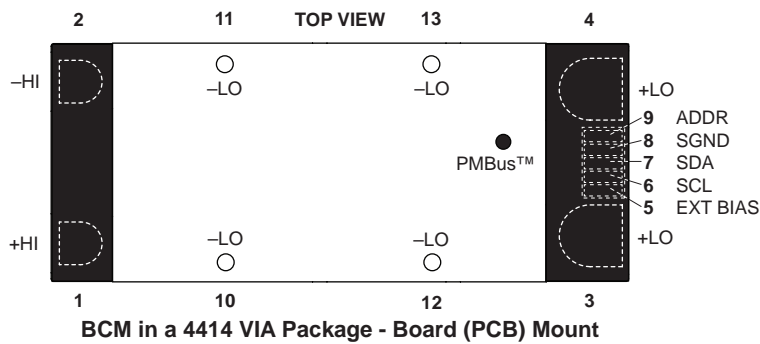
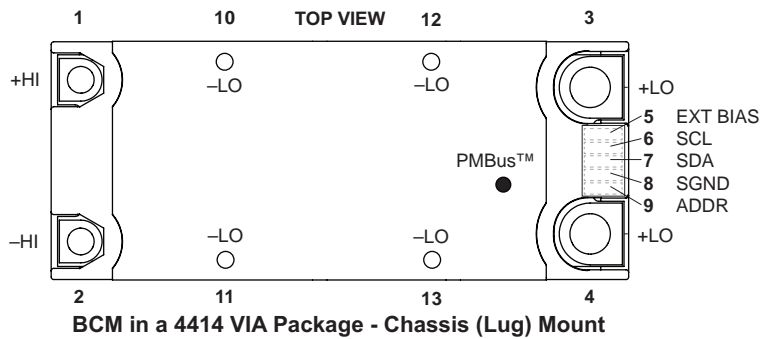

Note: The dot on the VIA housing indicates the location of the signal pin 9.

Pin Descriptions

Pin Number	Signal Name	Type	Function
1	+HI	HIGH SIDE POWER	Positive transformer power terminal on high voltage side
2	-HI	HIGH SIDE POWER RETURN	Negative transformer power terminal on high voltage side
3, 4	+LO	LOW SIDE POWER	Positive transformer power terminal on low voltage side
5	EXT BIAS	INPUT	5V supply input
6	SCL	INPUT	I <sup>2</sup> C Clock, PMBus™ Compatible
7	SDA	INPUT/OUTPUT	I <sup>2</sup> C Data, PMBus™ Compatible
8	SGND	LOW SIDE SIGNAL RETURN	Signal Ground
9	ADDR	INPUT	Address assignment - Resistor based
10, 11, 12, 13	-LO	LOW SIDE POWER RETURN	Negative transformer power terminal on low voltage side

Note: All signal pins (5, 6, 7, 8, 9) are referenced to low voltage side and isolated from the high voltage side.

## Absolute Maximum Ratings

The absolute maximum ratings below are stress ratings only. Operation at or beyond these maximum ratings can cause permanent damage to the device.

Parameter	Comments	Min	Max	Unit
+HI to -HI		-1	480	V
HI_DC or LO_DC slew rate			N/A	V/ $\mu$ s
+LO to -LO		-1	15	V
EXT BIAS to SGND		-0.3	10	V
			0.15	A
SCL to SGND		-0.3	5.5	V
SDA to SGND		-0.3	5.5	V
ADDR to SGND		-0.3	3.6	V
Dielectric Withstand*	See note below			
High Voltage Side to Case	Basic Insulation	2121		V <sub>DC</sub>
High Voltage Side to Low Voltage Side	Reinforced Insulation (4242V <sub>DC</sub> )	2121		V <sub>DC</sub>
Low Voltage Side to Case	Functional Insulation	N/A		V <sub>DC</sub>

\* Please see Dielectric Withstand section for details regarding test procedure, test values and insulation. The SELV side (-LO) is directly connected to the case of the BCM in a VIA package.

Electrical Specifications

Specifications apply over all line and load conditions, unless otherwise noted; **Boldface** specifications apply over the temperature range of -40°C ) T<sub>CASE</sub> ) 100°C (T-Grade); All other specifications are at T<sub>CASE</sub> = 25°C unless otherwise noted.

Attribute	Symbol	Conditions / Notes	Min	Typ	Max	Unit
<b>General Powertrain High Voltage Side to Low Voltage Side Specification (Forward Direction)</b>						
HI Side Input Voltage range, continuous	V <sub>HI_DC</sub>		<b>260</b>		<b>410</b>	V
HI Side Input Voltage range, transient	V <sub>HI_TRANS</sub>		<b>260</b>		<b>410</b>	V
V <sub>HI</sub> μController	V <sub>μC_ACTIVE</sub>	V <sub>HI_DC</sub> voltage where μC is initialized, (powertrain inactive)			130	V
HI to LO Input Quiescent Current	I <sub>HI_Q</sub>	Disabled, V <sub>HI_DC</sub> = 384V		2		mA
		T <sub>CASE</sub> ) 100°C			4	
HI to LO No Load Power Dissipation	P <sub>HI_NL</sub>	V <sub>HI_DC</sub> = 384V, T <sub>CASE</sub> = 25°C		11	15	W
		V <sub>HI_DC</sub> = 384V	<b>5.9</b>		<b>24</b>	
		V <sub>HI_DC</sub> = 260V to 410V, T <sub>CASE</sub> = 25 °C			16	
		V <sub>HI_DC</sub> = 260V to 410V			<b>25</b>	
HI to LO Inrush Current Peak	I <sub>HI_INR_PK</sub>	V <sub>HI_DC</sub> = 410V, C <sub>LO_EXT</sub> = 1000μF, R <sub>LOAD_LO</sub> = 25% of full load current		10		A
		T <sub>CASE</sub> ) 100°C			15	
DC HI Side Input Current	I <sub>HI_IN_DC</sub>	At I <sub>LO_OUT_DC</sub> = 125A, T <sub>CASE</sub> ) 95°C			4.1	A
Transformation Ratio	K	High Voltage to Low Voltage, K = V <sub>LO_DC</sub> / V <sub>HI_DC</sub> , at no load		1/32		V/V
LO Side Output Current (continuous)	I <sub>LO_OUT_DC</sub>	T <sub>CASE</sub> ) 95°C			125	A
LO Side Output Current (pulsed)	I <sub>LO_OUT_PULSE</sub>	2ms pulse, 25% Duty cycle, I <sub>LO_OUT_AVG</sub> ) 50% rated I <sub>LO_OUT_DC</sub>			167	A
HI to LO Efficiency (ambient)	d <sub>AMB</sub>	V <sub>HI_DC</sub> = 384V, I <sub>LO_OUT_DC</sub> = 125A	96.2	97		%
		V <sub>HI_DC</sub> = 260V to 410V, I <sub>LO_OUT_DC</sub> = 125A	95.2			
		V <sub>HI_DC</sub> = 384V, I <sub>LO_OUT_DC</sub> = 62.5A	96.5	97.4		
HI to LO Efficiency (hot)	d <sub>HOT</sub>	V <sub>HI_DC</sub> = 384V, I <sub>LO_OUT_DC</sub> = 125A, T <sub>CASE</sub> = 95°C	95.8	97		%
HI to LO Efficiency (over load range)	d <sub>20%</sub>	25A < I <sub>LO_OUT_DC</sub> < 125A	95			%
HI to LO Output Resistance	R <sub>LO_COLD</sub>	V <sub>HI_DC</sub> = 384V, I <sub>LO_OUT_DC</sub> = 125A, T <sub>CASE</sub> = -40°C	1.6	1.9	2.3	m1
	R <sub>LO_AMB</sub>	V <sub>HI_DC</sub> = 384V, I <sub>LO_OUT_DC</sub> = 125A	2.0	2.4	2.8	
	R <sub>LO_HOT</sub>	V <sub>HI_DC</sub> = 384V, I <sub>LO_OUT_DC</sub> = 125A, T <sub>CASE</sub> = 95°C	2.5	2.8	3.2	
Switching Frequency	F <sub>SW</sub>	Frequency of the LO Side Voltage Ripple = 2x F <sub>SW</sub>	<b>0.95</b>	1.00	<b>1.05</b>	MHz
LO Side Output Voltage Ripple	V <sub>LO_OUT_PP</sub>	C <sub>LO_EXT</sub> = 0μF, I <sub>LO_OUT_DC</sub> = 125A, V <sub>HI_DC</sub> = 384V, 20MHz BW		195		mV
		T <sub>CASE</sub> ) 100°C			250	

Electrical Specifications (Cont.)

Specifications apply over all line and load conditions, unless otherwise noted; **Boldface** specifications apply over the temperature range of -40°C ) T<sub>CASE</sub> ) 100°C (T-Grade); All other specifications are at T<sub>CASE</sub> = 25°C unless otherwise noted.

Attribute	Symbol	Conditions / Notes	Min	Typ	Max	Unit
<b>General Powertrain High Voltage Side to Low Voltage Side Specification (Forward Direction) Cont.</b>						
Effective HI Side Capacitance (Internal)	C <sub>HI_INT</sub>	Effective Value at 384V <sub>HI_DC</sub>		0.4		μF
Effective LO Side Capacitance (Internal)	C <sub>LO_INT</sub>	Effective Value at 12V <sub>LO_DC</sub>		238		μF
Effective LO Side Output Capacitance (External)	C <sub>LO_OUT_EXT</sub>	Excessive capacitance may drive module into SC protection			<b>1000</b>	μF
Effective LO Side Output Capacitance (External)	C <sub>LO_OUT_AEXT</sub>	C <sub>LO_OUT_AEXT</sub> Max = N * 0.5 * C <sub>LO_OUT_EXT</sub> MAX, where N = the number of units in parallel				
<b>Powertrain Protection High Voltage Side to Low Voltage Side (Forward Direction)</b>						
Auto Restart Time	t <sub>AUTO_RESTART</sub>	Startup into a persistent fault condition. Non-Latching fault detection given V <sub>HI_DC</sub> > V <sub>HI_UVLO+</sub>	<b>290</b>		<b>360</b>	ms
HI Side Overvoltage Lockout Threshold	V <sub>HI_OVLO+</sub>		<b>430</b>	440	<b>450</b>	V
HI Side Overvoltage Recovery Threshold	V <sub>HI_OVLO-</sub>		<b>410</b>	430	<b>440</b>	V
HI Side Overvoltage Lockout Hysteresis	V <sub>HI_OVLO_HYST</sub>			10		V
HI Side Overvoltage Lockout Response Time	t <sub>HI_OVLO</sub>			100		μs
HI Side Soft-Start Time	t <sub>HI_SOFT-START</sub>	From powertrain active. Fast Current limit protection disabled during Soft-Start		1		ms
LO Side Output Overcurrent Trip Threshold	I <sub>LO_OUT_OCP</sub>		<b>135</b>	170	<b>210</b>	A
LO Side Output Overcurrent Response Time Constant	t <sub>LO_OUT_OCP</sub>	Effective internal RC filter		3		ms
LO Side Output Short Circuit Protection Trip Threshold	I <sub>LO_OUT_SCP</sub>		<b>187</b>			A
LO Side Output Short Circuit Protection Response Time	t <sub>LO_OUT_SCP</sub>			1		μs
Overtemperature Shutdown Threshold	t <sub>OTP+</sub>	Temperature sensor located inside controller IC (Internal Temperature)	<b>125</b>			°C

Electrical Specifications (Cont.)

Specifications apply over all line and load conditions, unless otherwise noted; **Boldface** specifications apply over the temperature range of -40°C ) T<sub>CASE</sub> ) 100°C (T-Grade); All other specifications are at T<sub>CASE</sub> = 25°C unless otherwise noted.

Attribute	Symbol	Conditions / Notes	Min	Typ	Max	Unit
<b>Powertrain Supervisory Limits High Voltage Side to Low Voltage Side (Forward Direction)</b>						
HI Side Overvoltage Lockout Threshold	V <sub>HI_OVLO+</sub>		<b>420</b>	434.5	<b>450</b>	V
HI Side Overvoltage Recovery Threshold	V <sub>HI_OVLO-</sub>		<b>405</b>	424	<b>440</b>	V
HI Side Overvoltage Lockout Hysteresis	V <sub>HI_OVLO_HYST</sub>			10.5		V
HI Side Overvoltage Lockout Response Time	t <sub>HI_OVLO</sub>			100		µs
HI Side Undervoltage Lockout Threshold	V <sub>HI_UVLO-</sub>		<b>200</b>	226	<b>250</b>	V
HI Side Undervoltage Recovery Threshold	V <sub>HI_UVLO+</sub>		<b>225</b>	244	<b>259</b>	V
HI Side Undervoltage Lockout Hysteresis	V <sub>HI_UVLO_HYST</sub>			15		V
HI Side Undervoltage Lockout Response Time	t <sub>HI_UVLO</sub>			100		µs
HI Side Undervoltage Startup Delay	t <sub>HI_UVLO+_DELAY</sub>	From V <sub>HI_DC</sub> = V <sub>HI_UVLO+</sub> to powertrain active, (i.e One time Startup delay form application of V <sub>HI_DC</sub> to V <sub>LO_DC</sub> )		20		ms
LO Side Output Overcurrent Trip Threshold	I <sub>LO_OUT_OCP</sub>		<b>159</b>	168	<b>177</b>	A
LO Side Output Overcurrent Response Time Constant	t <sub>LO_OUT_OCP</sub>	Effective internal RC filter		2		ms
Overtemperature Shutdown Threshold	t <sub>OTP+</sub>	Temperature sensor located inside controller IC (Internal Temperature)	<b>125</b>			°C
Overtemperature Recovery Threshold	t <sub>OTP-</sub>	Temperature sensor located inside controller IC (Internal Temperature)	105	110	115	°C
Undertemperature Shutdown Threshold	t <sub>UTP</sub>	Temperature sensor located inside controller IC; Protection not available for M-Grade units.			-45	°C
Undertemperature Restart Time	t <sub>UTP_RESTART</sub>	Startup into a persistent fault condition. Non-Latching fault detection given V <sub>HI_DC</sub> > V <sub>HI_UVLO+</sub>		3		s

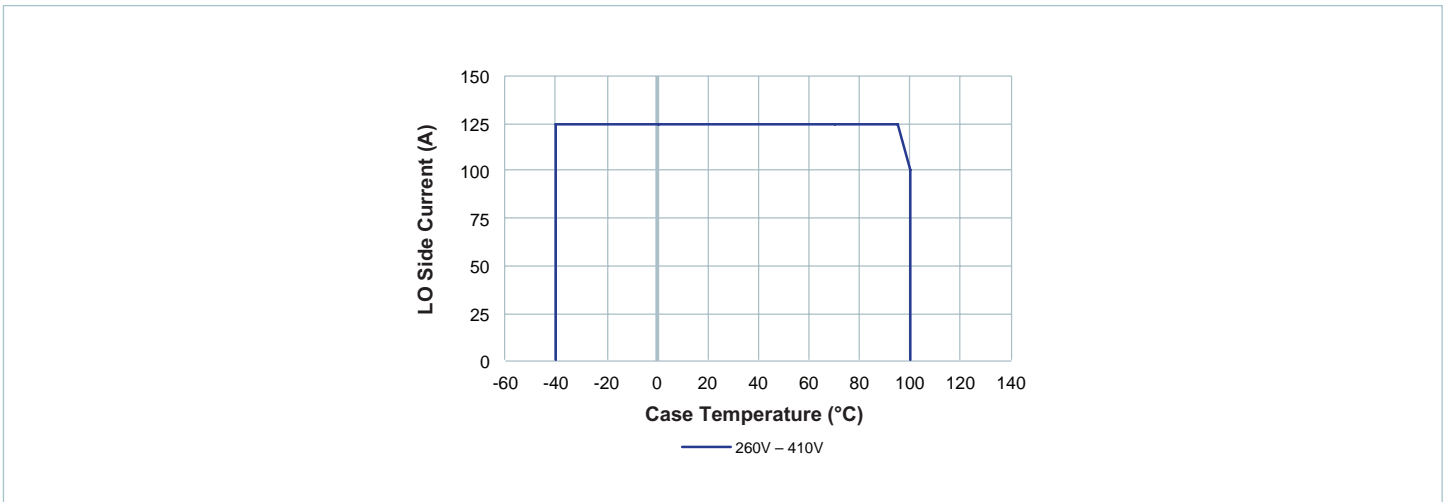

Figure 1 — Specified thermal operating area

1. The BCM in a VIA Package is cooled through bottom case (bottom housing).
2. The thermal rating of the BCM in a VIA Package is based on typical measured device efficiency.
3. The case temperature in the graph is the measured temperature of the bottom housing, such that operating internal junction temperature of the BCM in a VIA Package does not exceed 125°C.

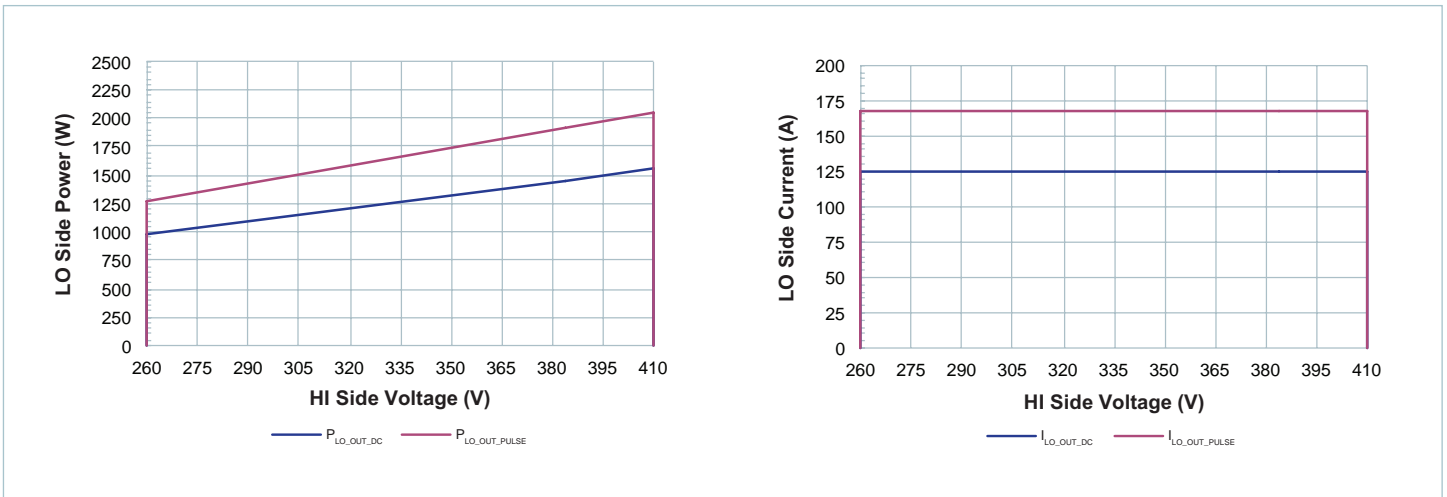

Figure 2 — Specified electrical operating area using rated  $R_{LO\_HOT}$

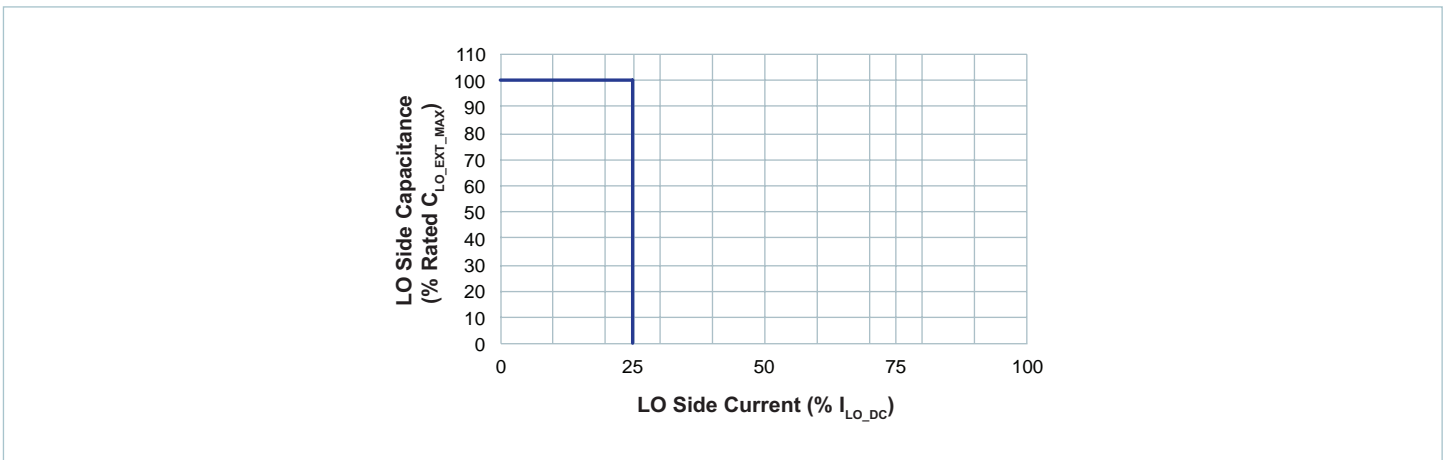

Figure 3 — Specified HI side start-up into load current and external capacitance



**PMBus™ Reported Characteristics**

Specifications apply over all line and load conditions, unless otherwise noted; **Boldface** specifications apply over the temperature range of -40°C ) T<sub>CASE</sub> ) 100°C (T-Grade); All other specifications are at T<sub>CASE</sub> = 25°C unless otherwise noted.

Monitored Telemetry					
• The BCM communication version is not intended to be used without a Digital Supervisor.					
ATTRIBUTE	DIGITAL SUPERVISOR PMBus™ READ COMMAND	ACCURACY (RATED RANGE)	FUNCTIONAL REPORTING RANGE	UPDATE RATE	REPORTED UNITS
HI Side Voltage	(88h) READ_VIN	± 5%(LL - HL)	130V to 450V	100µs	V <sub>ACTUAL</sub> = V <sub>REPORTED</sub> × 10 <sup>-1</sup>
HI Side Current	(89h) READ_IIN	± 20%(10 - 20% of FL) ± 5%(20 - 133% of FL)	-0.85A to 5.9A	100µs	I <sub>ACTUAL</sub> = I <sub>REPORTED</sub> × 10 <sup>-3</sup>
LO Side Voltage <sup>[1]</sup>	(8Bh) READ_VOUT	± 5%(LL - HL)	4.25V to 14V	100µs	V <sub>ACTUAL</sub> = V <sub>REPORTED</sub> × 10 <sup>-1</sup>
LO Side Current	(8Ch) READ_IOUT	± 20%(10 - 20% of FL) ± 5%(20 - 133% of FL)	-27A to 190A	100µs	I <sub>ACTUAL</sub> = I <sub>REPORTED</sub> × 10 <sup>-2</sup>
LO Side Resistance	(D4h) READ_ROUT	± 5%(50 - 100% of FL) at NL ± 10%(50 - 100% of FL)(LL - HL)	1.0m1 to 3.0m1	100ms	R <sub>ACTUAL</sub> = R <sub>REPORTED</sub> × 10 <sup>-5</sup>
Temperature <sup>[2]</sup>	(8Dh) READ_TEMPERATURE_1	± 7°C(Full Range)	- 55°C to 130°C	100ms	T <sub>ACTUAL</sub> = T <sub>REPORTED</sub>

<sup>[1]</sup> Default READ LO side Voltage returned when unit is disabled = -300V.

<sup>[2]</sup> Default READ Temperature returned when unit is disabled = -273°C.

Variable Parameter					
<ul style="list-style-type: none"> <li>• Factory setting of all below Thresholds and Warning limits are 100% of listed protection values.</li> <li>• Variables can be written only when module is disabled either EN pulled low or V<sub>HI</sub> &lt; V<sub>HI_UVLO</sub>.</li> <li>• Module must remain in a disabled mode for 3 ms after any changes to the below variables allowing ample time to commit changes to EEPROM.</li> </ul>					
ATTRIBUTE	DIGITAL SUPERVISOR PMBus™ COMMAND <sup>[3]</sup>	CONDITIONS / NOTES	ACCURACY (RATED RANGE)	FUNCTIONAL REPORTING RANGE	DEFAULT VALUE
HI Side Overvoltage Protection Limit	(55h) VIN_OV_FAULT_LIMIT	V <sub>HI_OVLO</sub> is automatically 3% lower than this set point	± 5%(LL - HL)	130V to 435V	100%
HI Side Overvoltage Warning Limit	(57h) VIN_OV_WARN_LIMIT		± 5%(LL - HL)	130V to 435V	100%
HI Side Undervoltage Protection Limit	(D7h) DISABLE_FAULTS	Can only be disabled to a preset default value	± 5%(LL - HL)	130V to 260V	100%
HI Side Overcurrent Protection Limit	(5Bh) IIN_OC_FAULT_LIMIT		± 20%(10 - 20% of FL) ± 5%(20 - 133% of FL)	0 to 5.25A	100%
HI Side Overcurrent Warning Limit	(5Dh) IIN_OC_WARN_LIMIT		± 20%(10 - 20% of FL) ± 5%(20 - 133% of FL)	0 to 5.25A	100%
Overtemperature Protection Limit	(4Fh) OT_FAULT_LIMIT	Internal Temperature	± 7°C(Full Range)	0 to 125°C	100%
Overtemperature Warning Limit	(51h) OT_WARN_LIMIT	Internal Temperature	± 7°C( Full Range)	0 to 125°C	100%
Turn on Delay	(60h) TON_DELAY	Additional time delay to the Undervoltage Startup Delay	± 50µs	0 to 100ms	0 ms

<sup>[3]</sup> Refer to internal µc datasheet for complete list of supported commands.





Timing Diagram (Forward Direction)

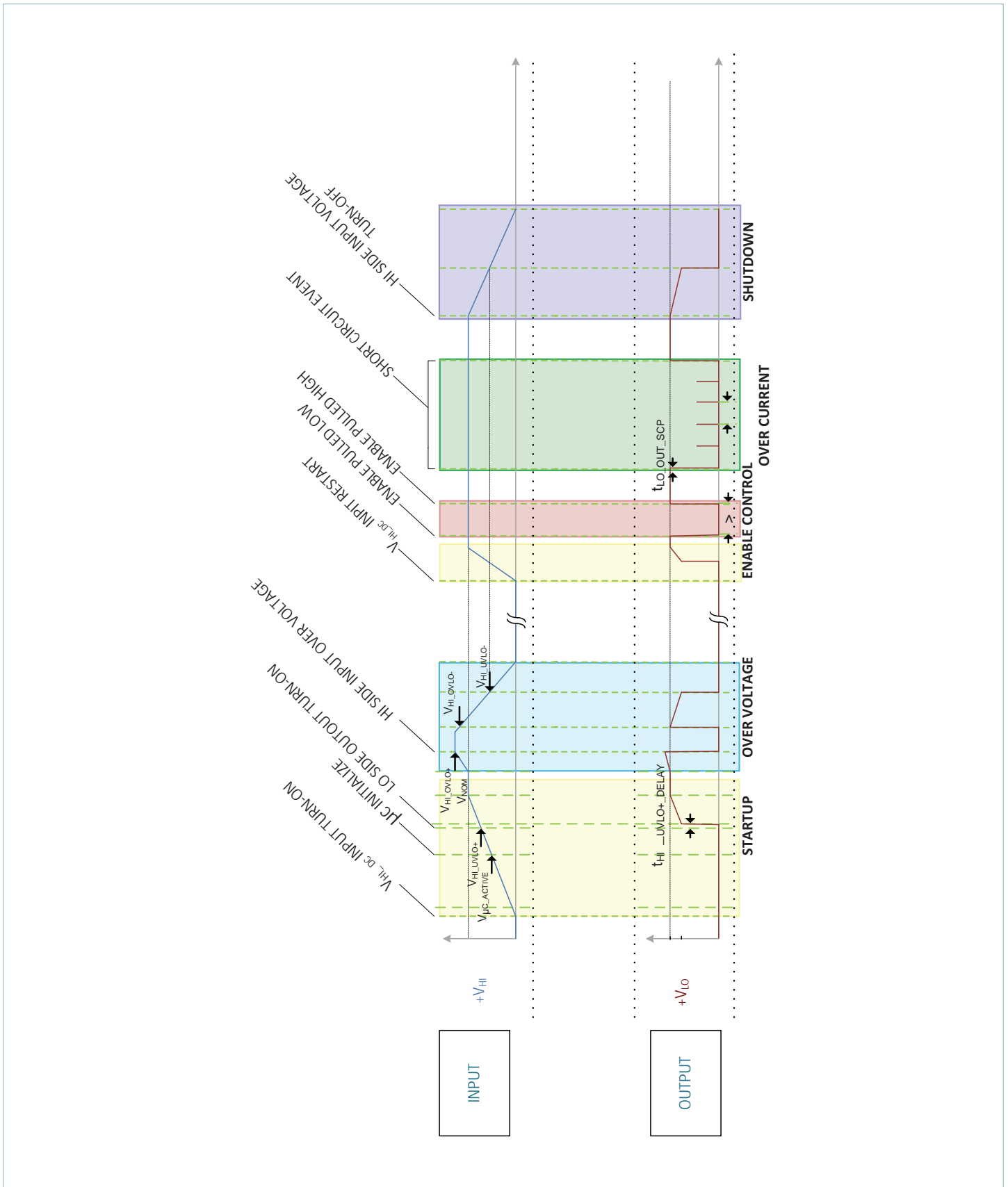

Application Characteristics

Product is mounted and temperature controlled via top side cold plate, unless otherwise noted. All data presented in this section are collected data from High Voltage sourced units processing power in forward direction. See associated figures for general trend data.

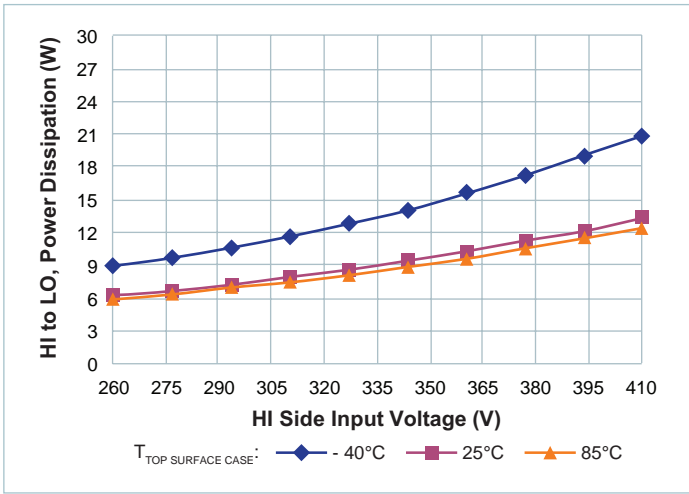

Figure 4 — No load power dissipation vs.  $V_{HI\_DC}$

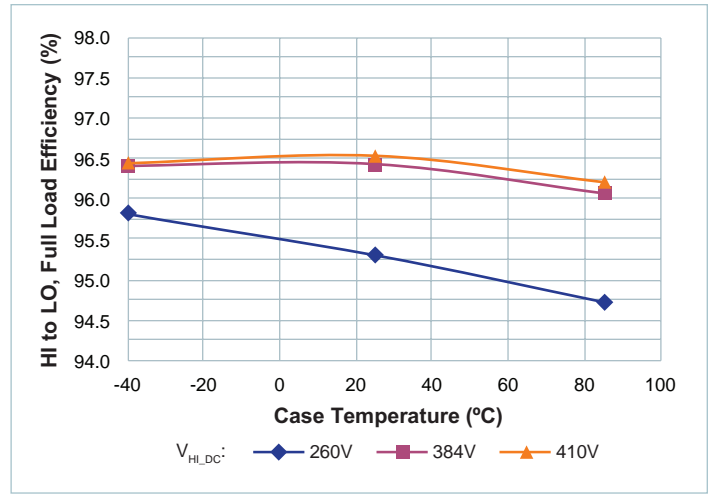

Figure 5 — Full load efficiency vs. temperature;  $V_{HI\_DC}$

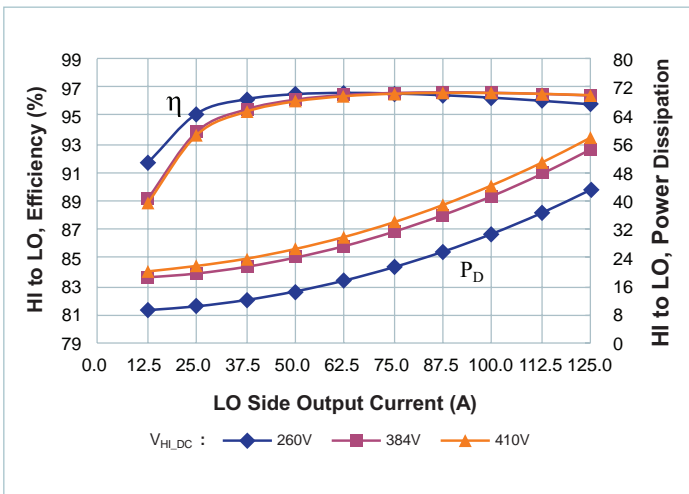

Figure 6 — Efficiency and power dissipation at  $T_{CASE} = -40^\circ\text{C}$

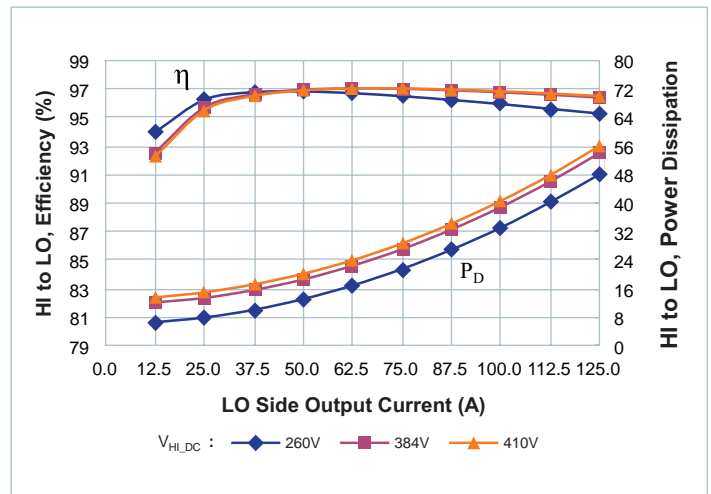

Figure 7 — Efficiency and power dissipation at  $T_{CASE} = 25^\circ\text{C}$

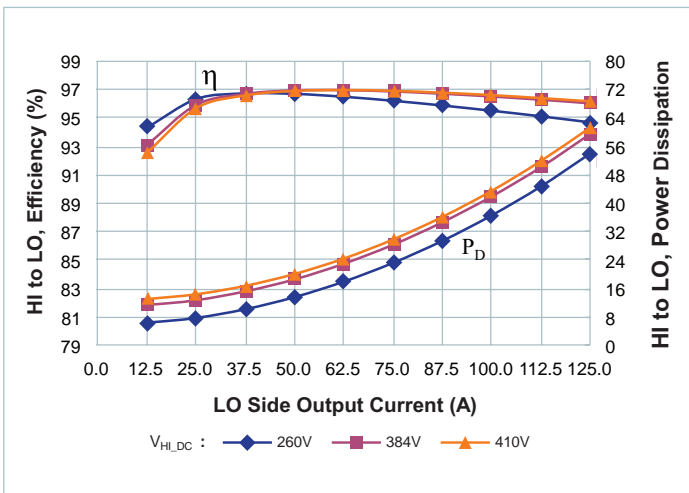

Figure 8 — Efficiency and power dissipation at  $T_{CASE} = 85^\circ\text{C}$

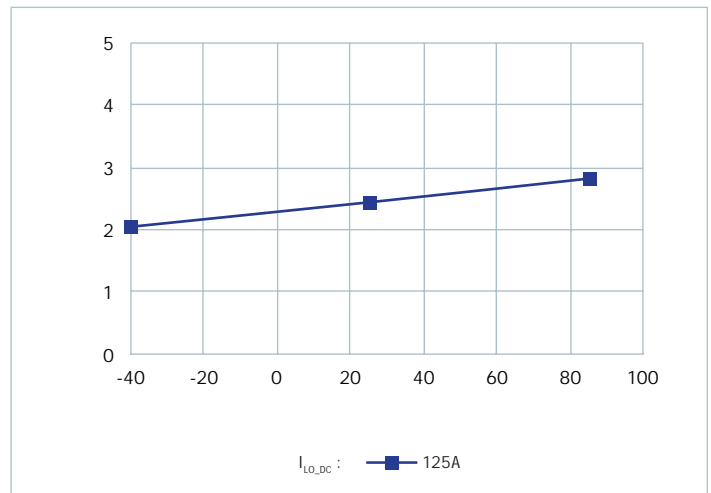
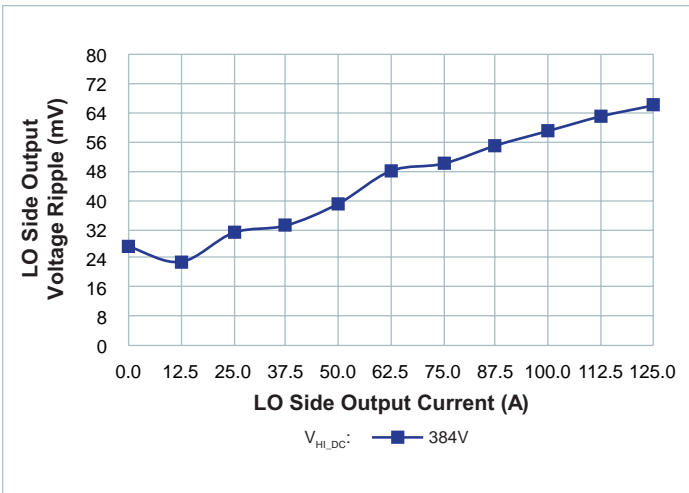
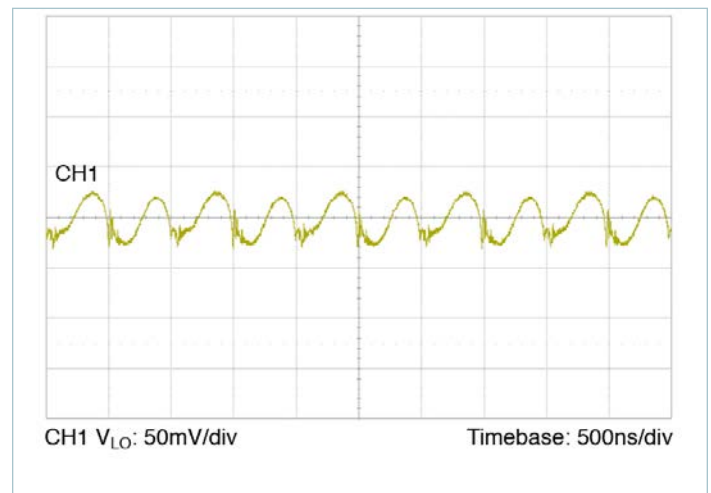

Figure 9 —  $R_{LO}$  vs. temperature; Nominal  $V_{HI\_DC}$   
 $I_{LO\_DC} = 125\text{A}$  at  $T_{CASE} = 85^\circ\text{C}$



**Figure 10** —  $V_{LO\_OUT\_PP}$  vs.  $I_{LO\_DC}$ ; No external  $C_{LO\_OUT\_EXT}$ , Board mounted module, scope setting : 20MHz analog BW



**Figure 11** — Full load ripple, 10  $\mu$ F  $C_{HI\_IN\_EXT}$ ; No external  $C_{LO\_OUT\_EXT}$ , Boardmounted module, scope setting : 20MHz analog BW

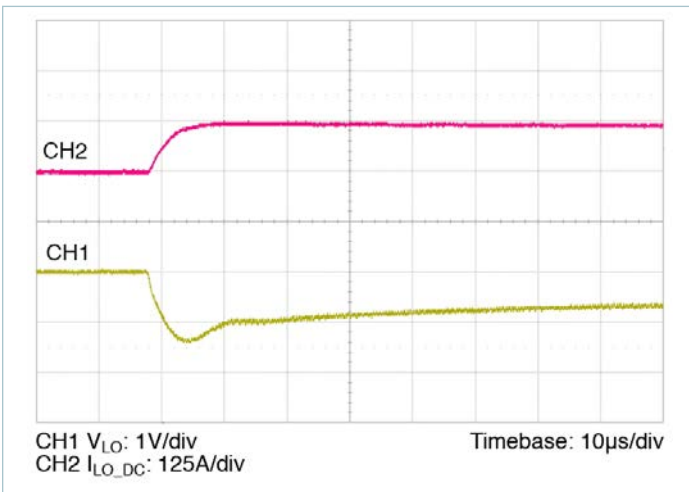

**Figure 12** — 0A– 125A transient response:  $C_{HI\_IN\_EXT} = 10\mu$ F, no external  $C_{LO\_OUT\_EXT}$

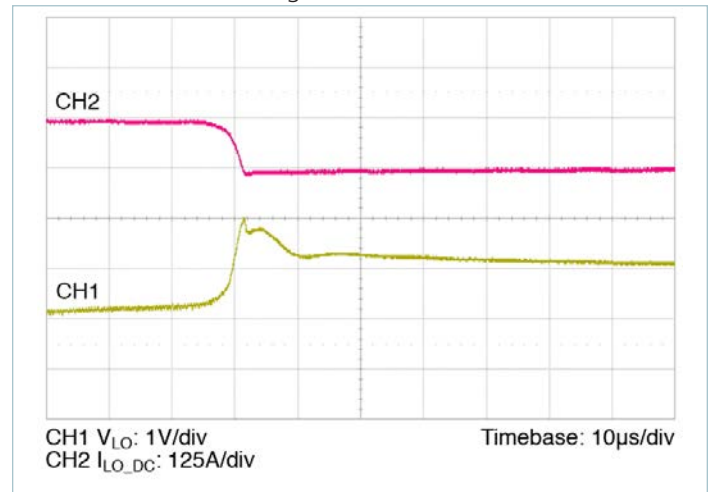

**Figure 13** — 125A – 0A transient response:  $C_{HI\_IN\_EXT} = 10\mu$ F, no external  $C_{LO\_OUT\_EXT}$

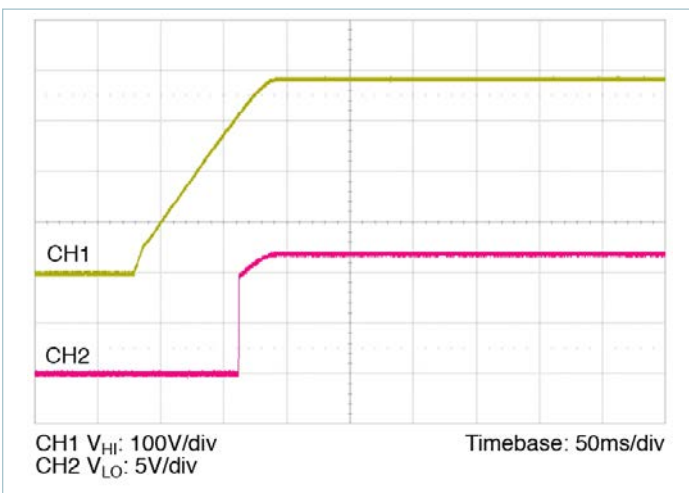

**Figure 14** — Start up from application of  $V_{HI\_DC} = 384$ V, 25%  $I_{LO\_DC}$ , 100%  $C_{LO\_OUT\_EXT}$

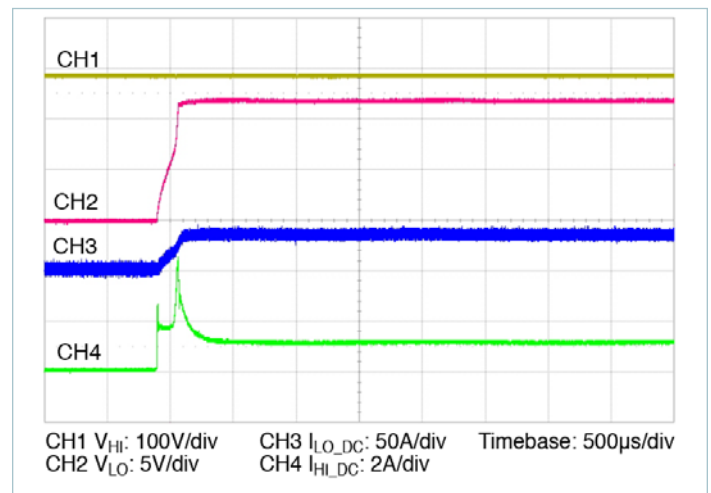

**Figure 15** — Start up from application of EN with pre-applied  $V_{HI\_DC} = 384$ V, 25%  $I_{LO\_DC}$ , 100%  $C_{LO\_OUT\_EXT}$

**General Characteristics (Cont.)**

Specifications apply over all line and load conditions, unless otherwise noted; **Boldface** specifications apply over the temperature range of -40°C ) T<sub>CASE</sub> ) 100°C (T-Grade); All other specifications are at T<sub>CASE</sub> = 25°C unless otherwise noted.

Attribute	Symbol	Conditions / Notes	Min	Typ	Max	Unit
<b>Safety</b>						
Isolation capacitance	C <sub>HI_LO</sub>	Unpowered unit	620	780	940	pF
Isolation resistance	R <sub>HI_LO</sub>	At 500V <sub>DC</sub>	10			M1
MTBF		MIL-HDBK-217Plus Parts Count - 25°C Ground Benign, Stationary, Indoors / Computer		2.31		MHrs
		Telcordia Issue 2 - Method I Case III; 25°C Ground Benign, Controlled		3.41		MHrs
Agency approvals / standards						
		CE Marked for Low Voltage Directive and RoHS Recast Directive, as applicable				

BCM in a VIA Package

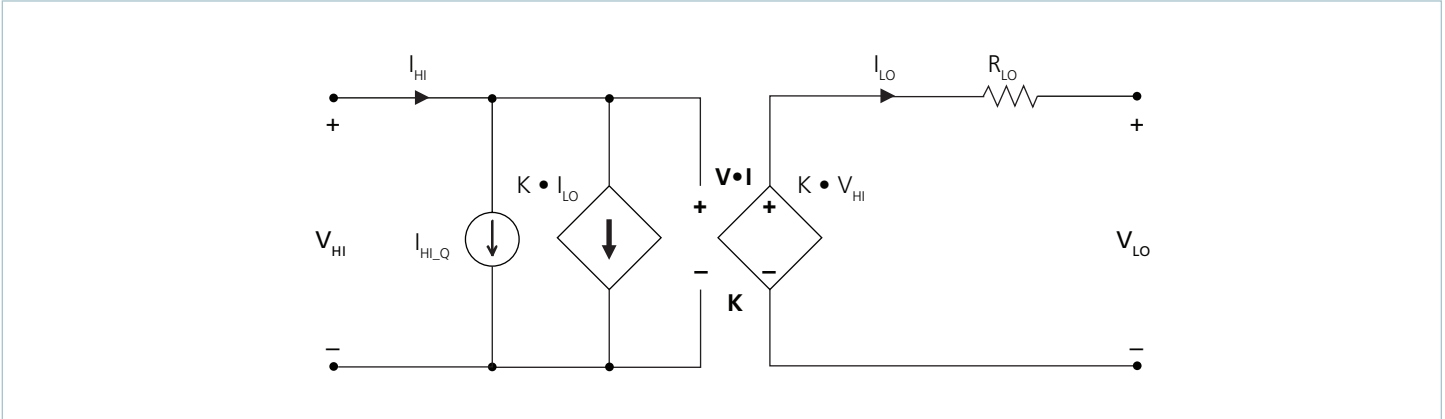

Figure 16 — BCM DC model (Forward Direction)

The BCM in a VIA package uses a high frequency resonant tank to move energy from high voltage side to low voltage side and vice versa. The resonant LC tank, operated at high frequency, is amplitude modulated as a function of HI side voltage and LO side current. A small amount of capacitance embedded in the high voltage side and low voltage side stages of the module is sufficient for full functionality and is key to achieving high power density.

The BCM4414xD1E13A2yzz can be simplified into the preceding model.

At no load:

$$V_{LO} = V_{HI} \cdot K \tag{1}$$

K represents the “turns ratio” of the BCM. Rearranging Eq (1):

$$K = \frac{V_{LO}}{V_{HI}} \tag{2}$$

In the presence of load, V<sub>LO</sub> is represented by:

$$V_{LO} = V_{HI} \cdot K - I_{LO} \cdot R_{LO} \tag{3}$$

and I<sub>LO</sub> is represented by:

$$I_{LO} = \frac{I_{HI} - I_{HI\_Q}}{K} \tag{4}$$

R<sub>LO</sub> represents the impedance of the BCM, and is a function of the R<sub>DS\_ON</sub> of the HI side and LO side MOSFETs, PC board resistance of HI side and LO side boards and the winding resistance of the power transformer. I<sub>HI\_Q</sub> represents the HI side quiescent current of the BCM control, gate drive circuitry, and core losses..

The use of DC voltage transformation provides additional interesting attributes. Assuming that R<sub>LO</sub> = 01 and I<sub>HI\_Q</sub> = 0A, Eq. (3) now becomes Eq. (1) and is essentially load independent, resistor R is now placed in series with V<sub>HI</sub>.

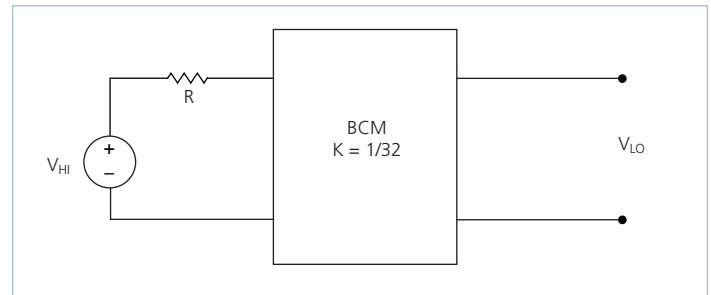

Figure 17 — K = 1/32 BCM with series HI side resistor

The relationship between V<sub>HI</sub> and V<sub>LO</sub> becomes:

$$V_{LO} = (V_{HI} - I_{HI} \cdot R) \cdot K \tag{5}$$

Substituting the simplified version of Eq. (4) (I<sub>HI\_Q</sub> is assumed = 0A) into Eq. (5) yields:

$$V_{LO} = V_{HI} \cdot K - I_{LO} \cdot R \cdot K^2 \tag{6}$$

This is similar in form to Eq. (3), where R<sub>LO</sub> is used to represent the characteristic impedance of the BCM. However, in this case a real R on the high voltage side of the BCM is effectively scaled by K<sup>2</sup> with respect to the low voltage side.

Assuming that R = 11 , the effective R as seen from the low voltage side is 1.0m1 , with K = 1/32.



A similar exercise should be performed with the addition of a capacitor or shunt impedance at the high voltage side of the BCM. A switch in series with  $V_{HI}$  is added to the circuit. This is depicted in Figure 18.

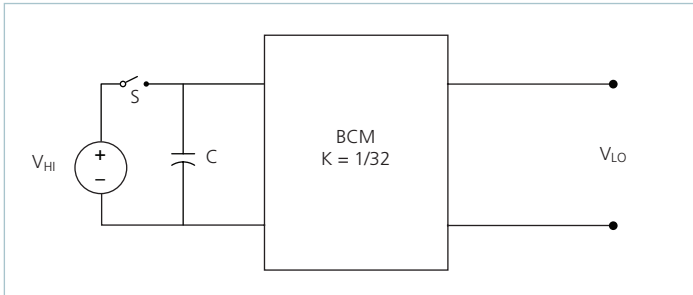

Figure 18 — BCM with High side capacitor

A change in  $V_{HI}$  with the switch closed would result in a change in capacitor current according to the following equation:

$$I_C(t) = C \frac{dV_{HI}}{dt} \tag{7}$$

Assume that with the capacitor charged to  $V_{HI}$ , the switch is opened and the capacitor is discharged through the idealized BCM. In this case,

$$I_C = I_{LO} \cdot K \tag{8}$$

substituting Eq. (1) and (8) into Eq. (7) reveals:

$$I_{LO} = \frac{C}{K^2} \cdot \frac{dV_{LO}}{dt} \tag{9}$$

The equation in terms of the LO side has yielded a  $K^2$  scaling factor for  $C$ , specified in the denominator of the equation.

A  $K$  factor less than unity results in an effectively larger capacitance on the low voltage side when expressed in terms of the high voltage side. With a  $K = 1/32$  as shown in Figure 18,  $C = 1\mu\text{F}$  would appear as  $C = 1024\mu\text{F}$  when viewed from the low voltage side.

Low impedance is a key requirement for powering a high-current, low-voltage load efficiently. A switching regulation stage should have minimal impedance while simultaneously providing appropriate filtering for any switched current. The use of a BCM between the regulation stage and the point of load provides a dual benefit of scaling down series impedance leading back to the source and scaling up shunt capacitance or energy storage as a function of its  $K$  factor squared. However, the benefits are not useful if the series impedance of the BCM is too high. The impedance of the BCM must be low, i.e. well beyond the crossover frequency of the system.

A solution for keeping the impedance of the BCM low involves switching at a high frequency. This enables small magnetic components because magnetizing currents remain low. Small magnetics mean small path lengths for turns. Use of low loss core material at high frequencies also reduces core losses.

The two main terms of power loss in the BCM module are:

- No load power dissipation ( $P_{HI\_NL}$ ): defined as the power used to power up the module with an enabled powertrain at no load.
- Resistive loss ( $R_{LO}$ ): refers to the power loss across the BCM module modeled as pure resistive impedance.

$$P_{DISSIPATED} = P_{HI\_NL} + P_{R_{LO}} \tag{10}$$

Therefore,

$$P_{LO\_OUT} = P_{HI\_IN} - P_{DISSIPATED} = P_{HI\_IN} - P_{HI\_NL} - P_{R_{LO}} \tag{11}$$

The above relations can be combined to calculate the overall module efficiency:

$$\begin{aligned} d &= \frac{P_{LO\_OUT}}{P_{HI\_IN}} = \frac{P_{HI\_IN} - P_{HI\_NL} - P_{R_{LO}}}{P_{HI\_IN}} \tag{12} \\ &= \frac{V_{HI} \cdot I_{HI} - P_{HI\_NL} - (I_{LO})^2 \cdot R_{LO}}{V_{HI} \cdot I_{HI}} \\ &= 1 - \left( \frac{P_{HI\_NL} + (I_{LO})^2 \cdot R_{LO}}{V_{HI} \cdot I_{HI}} \right) \end{aligned}$$

## Thermal Considerations

The VIA™ package provides effective conduction cooling from either of the two module surfaces. Heat may be removed from the top surface, the bottom surface or both. The extent to which these two surfaces are cooled is a key component for determining the maximum power that can be processed by a VIA, as can be seen from specified thermal operating area in Figure 1. Since the VIA has a maximum internal temperature rating, it is necessary to estimate this internal temperature based on a system-level thermal solution. To this purpose, it is helpful to simplify the thermal solution into a roughly equivalent circuit where power dissipation is modeled as a current source, isothermal surface temperatures are represented as voltage sources and the thermal resistances are represented as resistors. Figure 19 shows the “thermal circuit” for the VIA module.

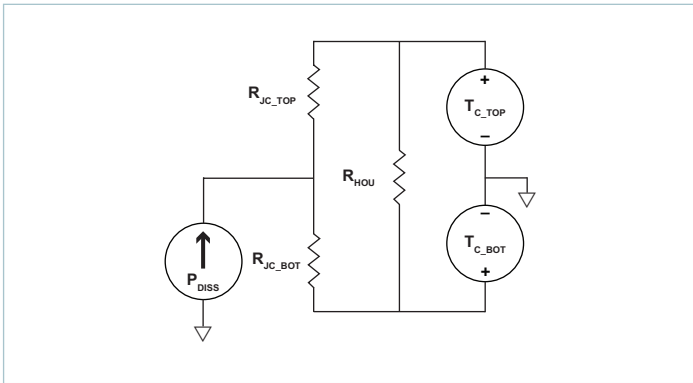

Figure 19 — Double sided cooling VIA thermal model

In this case, the internal power dissipation is  $P_{DISS}$ ,  $R_{JC\_TOP}$  and  $R_{JC\_BOT}$  are thermal resistance characteristics of the VIA module and the top and bottom surface temperatures are represented as  $T_{C\_TOP}$ , and  $T_{C\_BOT}$ . It is interesting to notice that the package itself provides a high degree of thermal coupling between the top and bottom case surfaces (represented in the model by the resistor  $R_{HOU}$ ). This feature enables two main options regarding thermal designs:

- Single side cooling: the model of Figure 19 can be simplified by calculating the parallel resistor network and using one simple thermal resistance number and the internal power dissipation curves; an example for bottom side cooling only is shown in Figure 20.

In this case,  $R_{JC}$  can be derived as following:

$$R_{JC} = \frac{(R_{JC\_TOP} + R_{HOU}) \cdot R_{JC\_BOT}}{R_{JC\_TOP} + R_{HOU} + R_{JC\_BOT}} \quad (14)$$

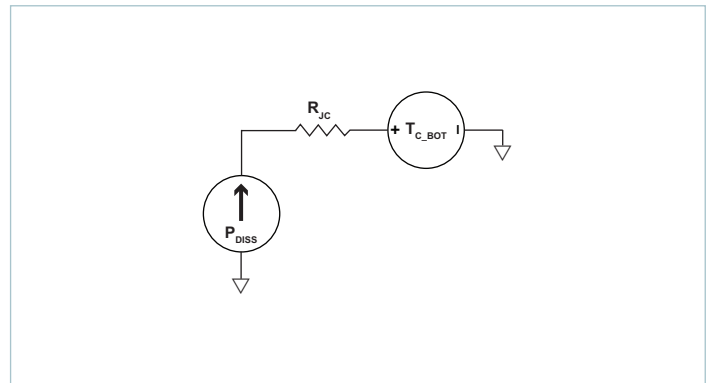

Figure 20 — Single-sided cooling VIA thermal model

- Double side cooling: while this option might bring limited advantage to the module internal components (given the surface-to-surface coupling provided), it might be appealing in cases where the external thermal system requires allocating power to two different elements, like for example heatsinks with independent airflows or a combination of chassis/air cooling.

## Current Sharing

The performance of the BCM in a VIA package is based on efficient transfer of energy through a transformer without the need of closed loop control. For this reason, the transfer characteristic can be approximated by an ideal transformer with a positive temperature coefficient series resistance.

This type of characteristic is close to the impedance characteristic of a DC power distribution system both in dynamic (AC) behavior and for steady state (DC) operation.

When multiple BCM modules of a given part number are connected in an array they will inherently share the load current according to the equivalent impedance divider that the system implements from the power source to the point of load.

Some general recommendations to achieve matched array impedances include:

- Dedicate common copper planes/wires within the PCB/Chassis to deliver and return the current to the VIA modules.
- Provide as symmetric a PCB/Wiring layout as possible among VIA™ modules

For further details see AN:016 Using BCM Bus Converters in High Power Arrays.

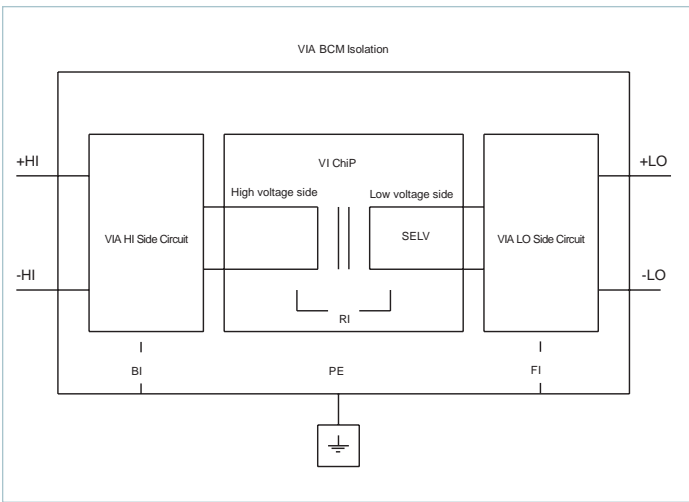

Figure 23 — BCM in a VIA package after final assembly

### Filtering

The BCM in a VIA Package has built-in single stage EMI filtering with hot-swap circuitry located on high voltage side. Typical test set-up block diagram for conducted emissions is shown in Figure 24. Hot-swap circuitry provides inrush current limiting through the MOSFET.

Further, along with internal ceramic capacitance, it reduces the voltage ripple. External LO side filtering can be added as needed. Ceramic capacitance can be used as a LO side bypass for this purpose. Moreover, along with hot-swap circuitry, it protects the VIA from overvoltage transients imposed by a system that would exceed maximum ratings and induce stresses. VIA HI side and LO side voltage ranges shall not be exceeded. An internal overvoltage function prevents operation outside of the normal operating HI side range. Even when disabled, the VIA is exposed to the applied voltage and the VIA must withstand it.

Given the wide bandwidth of the VIA, the source response is generally the limiting factor in the overall system response. Anomalies in the response of the source will appear at the LO side of the module multiplied by its K factor.

Total load capacitance at the LO side of the VIA shall not exceed the specified maximum for correct operation of it in startup and steady state conditions. Owing to the wide bandwidth and small LO side impedance of the VIA, low frequency bypass capacitance and significant energy storage may be more densely and efficiently provided by adding capacitance at the HI side of the VIA. At frequencies less than 500KHz, the VIA appears as an impedance of  $R_{LO}$  between the source and load.

Within this frequency range, capacitance at the HI side appears as effective capacitance on the LO side per the relationship defined in equation (15).

This enable a reduction in the size and number of capacitors used in a typical system.

$$C_{LO} = \frac{C_{HI}}{K^2} \tag{15}$$

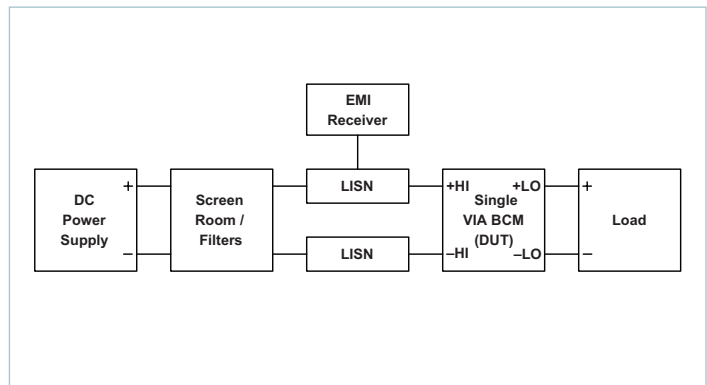

Figure 24 — Typical test set-up block diagram for Conducted Emissions

### Hot Swap

Many applications use a power architecture based on a 380V<sub>DC</sub> distribution bus. This supply level is emerging as a new standard and efficient means for distributing power through boards, racks and chassis mounted Telecom and Datacom system. The interconnect between the different modules is accomplished with a backplane and motherboard. Power is commonly provided to the various module slots via a 380V<sub>DC</sub> distribution bus.

Removing the faulty module from the rack is relatively easy, provided the remaining power modules can support the step increase in load. Plugging in the replacement module has more potential for problems, as it will present an uncharged capacitor load and draw a large inrush current. This could cause a momentary, but unacceptable interruption or sag to the backplane power bus if not limited. The problem can also arise if ordinary power module connectors are used, since the connector pins will engage and disengage in a random and unpredictable sequence during insertion and removal.

Hot swap or hot plug is the highly desirable feature in many applications, but it also creates several issues that must be addressed in the system design. A number of related phenomena occur with a live insertion and removal event, including bouncing, arcing between HI side connector pins, larger voltage and current transients. Hot swap circuitry in the converter modules protects the module and the rest of the system from the problem associated with live insertion.

To meet the maintenance, reconfiguration, redundancy and system upgrade, this new BCM module is being designed to address the function of hot-swapping at the 380V<sub>DC</sub> distribution bus. This new module provides a high level of integration for DC-DC converters in 380V<sub>DC</sub> distributions, saving the system designer design time and critical board space. Hot swap circuitry as shown in Figure 29 uses an active MOSFET switching device in the HI side line. During insertion, the MOSFET is driven into a resistive state to limit the inrush current, and then when the inserted module's HI side capacitor has charged, the MOSFET becomes fully conductive to avoid the voltage drop losses. Performance verification is further illustrated through scope plots of circuit's response to various live insertion events.

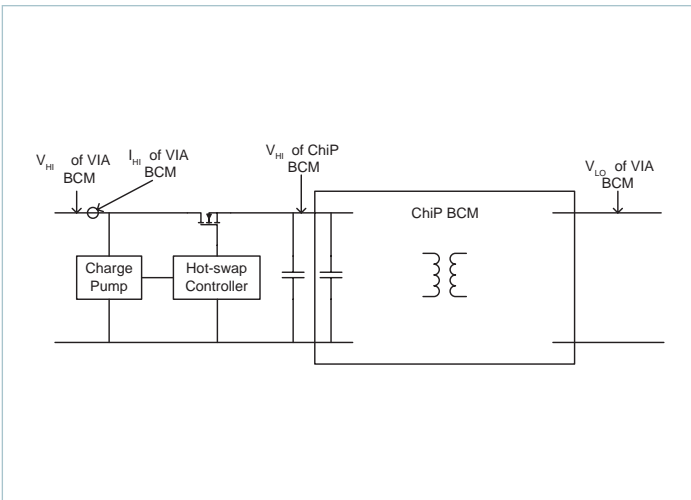

**Figure 25** — High-Level Diagram for 384 V<sub>DC</sub> Hot Swap with ChiP BCM DC-DC converter

**Hot Swap Test – Scope Pictures**

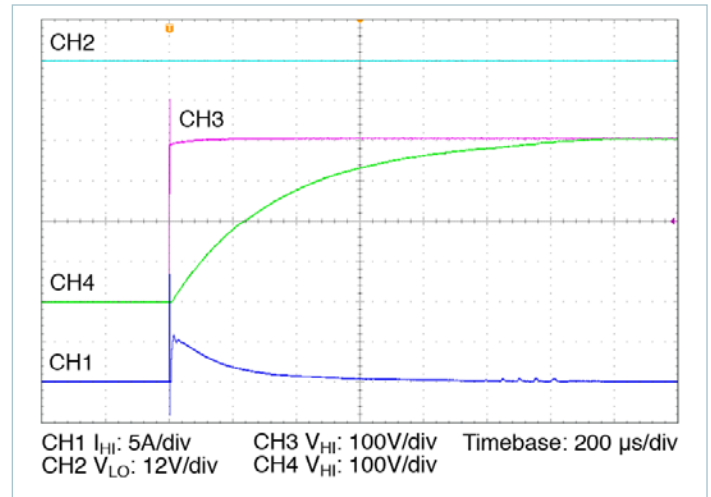

**Figure 27** — Hot swap start-up

Ch1:  $I_{HI}$  of BCM#2

Ch2:  $V_{LO}$  of BCM#2

Ch3:  $V_{HI}$  of BCM#2 shows the fast high side voltage transient at the high side terminal of BCM#2

Ch4:  $V_{HI}$  of ChiP BCM#2 shows the soft start charging the high side capacitor as shown, time constant depends upon the gate signal.

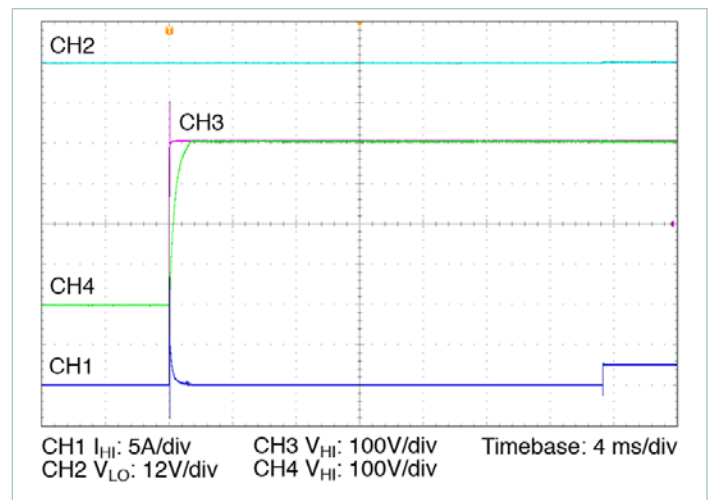
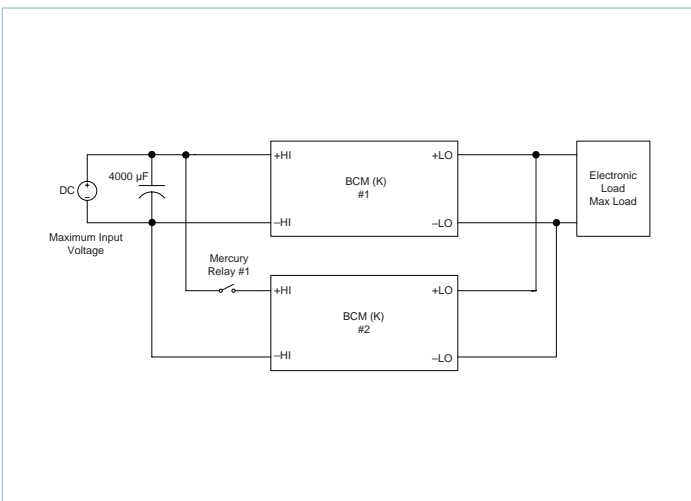

**Figure 28** — Same as Figure 30 but at a bigger time scale shows the appearance of the BCM#2

Overall, the objective is always remains the same in hot swap applications; to give system designer the opportunity to build hot swap capability into redundant power module arrays. This allows telecoms and other mission critical applications to continue without interruption even through failure and replacement of one or possibly more of their power modules.

**Hot Swap Test – Test circuit and Procedure**

- Two BCMs in parallel with mercury relay#1 open
- Close mercury relay#1 and measure inrush current going into #2 BCM



**Figure 26** — Test Circuit

## System Diagram for PMBus™ Interface

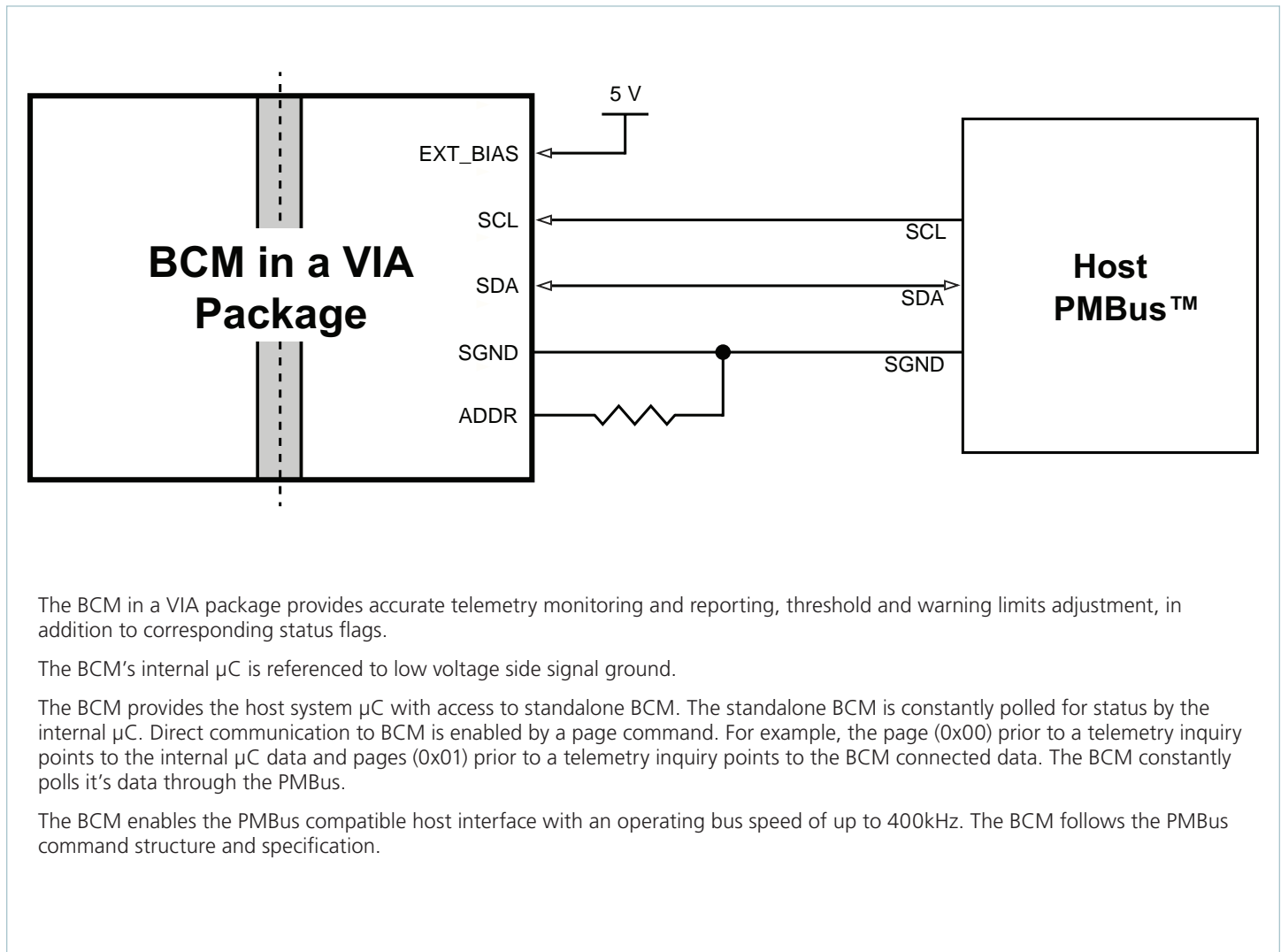

## PMBus™ Interface

Refer to “PMBus Power System Management Protocol Specification Revision 1.2, Part I and II” for complete PMBus specifications details visit <http://pmbus.org>.

## Device Address

The PMBus address (ADDR Pin) should be set to one of a predetermined 16 possible addresses shown in the table below using a resistor between ADDR pin and SGND pin.

The BCM accepts only a fixed and persistent address and does not support SMBus address resolution protocol. At initial power up, the BCM internal μC will sample the address pin voltage, and will hold this address until device power is removed.

ID	Slave Address	HEX	Recommended Resistor R <sub>ADDR</sub> (1)
1	1010 000b	50h	487
2	1010 001b	51h	1050
3	1010 010b	52h	1870
4	1010 011b	53h	2800
5	1010 100b	54h	3920
6	1010 101b	55h	5230
7	1010 110b	56h	6810
8	1010 111b	57h	8870
9	1011 000b	58h	11300
10	1011 001b	59h	14700
11	1011 010b	5Ah	19100
12	1011 011b	5Bh	25500
13	1011 100b	5Ch	35700
14	1011 101b	5Dh	53600
15	1011 110b	5Eh	97600
16	1011 111b	5Fh	316000

## Reported DATA Formats

The BCM internal μC employs a direct data format where all reported internal μC measurements are in Volts, Amperes, Degrees Celsius, or Seconds. The host uses the following PMBus specification to interpret received values metric prefixes. Note that the Coefficients command is not supported:

$$X = \left(\frac{1}{m}\right) \cdot (Y \cdot 10^R - b)$$

Where:

X, is a “real world” value in units (A, V, °C, s)

Y, is a two’s complement integer received from the internal μC

m, b and R are two’s complement integers defined as follows:

Command	Code	m	R	b
TON_DELAY	60h	1	3	0
READ_VIN	88h	1	1	0
READ_IIN	89h	1	3	0
READ_VOUT	8Bh	1	1	0
READ_IOUT	8Ch	1	2	0
READ_TEMPERATURE_1	8Dh	1	0	0
READ_POUT	96h	1	0	0
MFR_VIN_MIN	A0h	1	0	0
MFR_VIN_MAX	A1h	1	0	0
MFR_VOUT_MIN	A4h	1	0	0
MFR_VOUT_MAX	A5h	1	0	0
MFR_IOUT_MAX	A6h	1	0	0
MFR_POUT_MAX	A7h	1	0	0
READ_K_FACTOR	D1h	65536	0	0
READ_BCM_ROUT	D4h	1	2	0

<sup>[1]</sup> Default READ LO side voltage returned when BCM unit is disabled = -300V.

<sup>[2]</sup> Default READ Temperature returned when BCM unit is disabled = -273°C.

No special formatting is required when lowering the supervisory limits and warnings.

## Supported Command List

Command	Code	Function	Default Data Content	Data Bytes
PAGE	00h	Access BCM stored information for all connected devices	00h	1
OPERATION	01h	Turn BCMs on or off	80h	1
ON_OFF_CONFIG	02h	Defines startup when power is applied as well as immediate on/off control over the BCMs	1Dh	1
CLEAR_FAULTS	03h	Clear all BCM and all internal $\mu$ C faults	N/A	None
CAPABILITY	19h	Internal $\mu$ C PMBus™ key capabilities set by factory	20h	1
OT_FAULT_LIMIT	4Fh <sup>[1]</sup>	BCM over temperature protection	64h	2
OT_WARN_LIMIT	51h <sup>[1]</sup>	BCM over temperature warning	64h	2
VIN_OV_FAULT_LIMIT	55h <sup>[1]</sup>	BCM $V_{HI}$ overvoltage warning	64h	2
VIN_OV_WARN_LIMIT	57h <sup>[1]</sup>	BCM $V_{HI}$ overvoltage protection	64h	2
IIN_OC_FAULT_LIMIT	58h <sup>[1]</sup>	BCM $I_{LO}$ overcurrent protection	64h	2
IIN_OC_WARN_LIMIT	5Dh <sup>[1]</sup>	BCM $I_{LO}$ overcurrent warning	64h	2
TON_DELAY	60h <sup>[1]</sup>	Startup delay additional to any BCM fixed delays	00h	2
STATUS_BYTE	78h	Summary of BCM faults	00h	1
STATUS_WORD	79h	Summary of BCM fault conditions	00h	2
STATUS_IOUT	7Bh	BCM overcurrent fault status	00h	1
STATUS_INPUT	7Ch	BCM overvoltage and under voltage fault status	00h	1
STATUS_TEMPERATURE	7Dh	BCM over temperature and under temperature fault status	00h	1
STATUS_CML	7Eh	Internal $\mu$ C PMBus Communication fault	00h	1
STATUS_MFR_SPECIFIC	80h	Other BCM status indicator	00h	1
READ_VIN	88h	Reads HI side voltage	FFFFh	2
READ_IIN	89h	Reads HI side current	FFFFh	2
READ_VOUT	8Bh	Reads LO side voltage	FFFFh	2
READ_IOUT	8Ch	Reads LO side current	FFFFh	2
READ_TEMPERATURE_1	8Dh	BCM temperature	FFFFh	2
READ_POUT	96h	Reads LO side power	FFFFh	2
PMBUS_REVISION	98h	Internal $\mu$ C PMBus compatible revision	22h	1
MFR_ID	99h	Internal $\mu$ C ID	"VI"	2
MFR_MODEL	9Ah	Internal $\mu$ C or BCM model	Part Number	18
MFR_REVISION	9Bh	Internal $\mu$ C or BCM revision	FW and HW revision	18
MFR_LOCATION	9Ch	Internal $\mu$ C or BCM factory location	"AP"	2
MFR_DATE	9Dh	Internal $\mu$ C or BCM manufacturing date	"YYWW"	4
MFR_SERIAL	9Eh	Internal $\mu$ C or BCM serial number	Serial Number	16
MFR_VIN_MIN	A0h	BCM Minimum rated $V_{HI}$	Varies per BCM	2
MFR_VIN_MAX	A1h	BCM Maximum rated $V_{HI}$	Varies per BCM	2
MFR_VOUT_MIN	A4h	BCM Minimum rated $V_{LO}$	Varies per BCM	2
MFR_VOUT_MAX	A5h	BCM Maximum rated $V_{LO}$	Varies per BCM	2
MFR_IOUT_MAX	A6h	BCM Maximum rated $I_{LO}$	Varies per BCM	2
MFR_POUT_MAX	A7h	BCM Maximum rated $P_{LO}$	Varies per BCM	2
BCM_EN_POLARITY	D0h <sup>[1]</sup>	Set BCM EN pin polarity	02h	1
READ_K_FACTOR	D1h	BCM K factor	Varies per BCM	2
READ_BCM_ROUT	D4h	BCM $R_{LO}$	Varies per BCM	2
SET_ALL_THRESHOLDS	D5h <sup>[1]</sup>	Set BCM supervisory warning and protection thresholds	646464646464h	6
DISABLE_FAULT	D7h <sup>[1]</sup>	Disable BCM overvoltage, overcurrent or under voltage supervisory faults	00h	2

<sup>[1]</sup> The BCM must be in a disabled state during a write message.

## Command Structure Overview

### Write Byte protocol:

The Host always initiates PMBus™ communication with a START bit. All messages are terminated by the Host with a STOP bit. In a write message, the master sends the slave address followed by a write bit. Once the slave acknowledges, the master proceeds with the command code and then similarly the data byte.

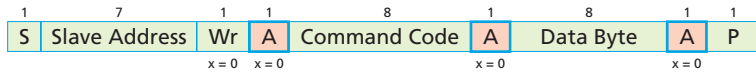

- S** Start Condition
- Sr** Repeated start Condition
- Rd** Read
- Wr** Write
- X** Indicated that field is required to have the value of x
- A** Acknowledge (bit may be 0 for an ACK or 1 for a NACK)
- P** Stop Condition
- From Master to Slave
- From Slave to Master
- ... Continued next line

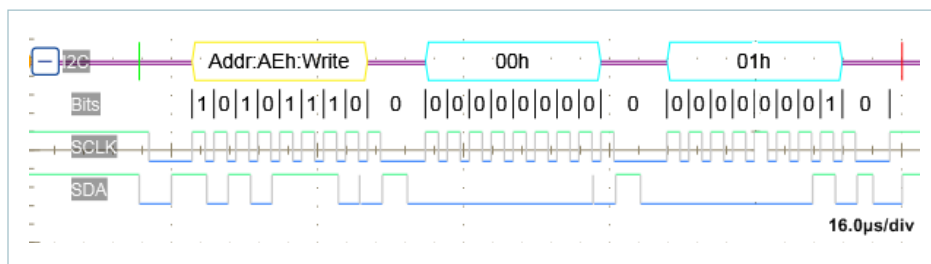

Figure 1 — PAGE COMMAND (00h), WRITE BYTE PROTOCOL

### Read Byte protocol:

A Read message begins by first sending a Write Command, followed by a REPEATED START Bit and a slave Address. After receiving the READ bit, the internal µC begins transmission of the Data responding to the Command. Once the Host receives the requested Data, it terminates the message with a NACK preceding a stop condition signifying the end of a read transfer.

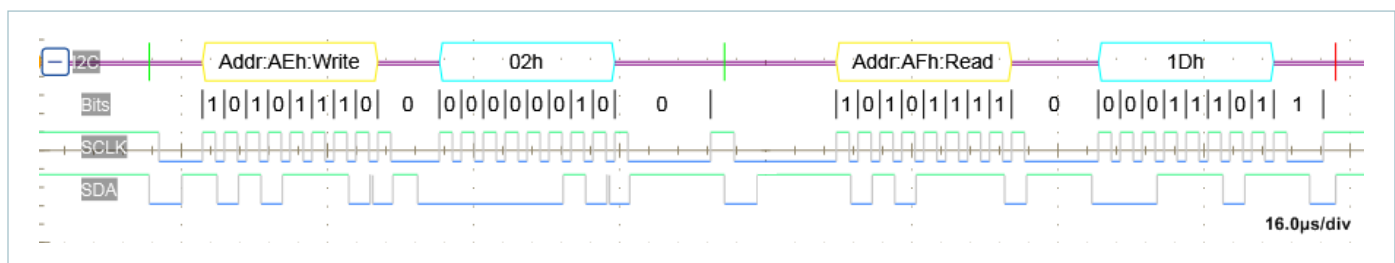
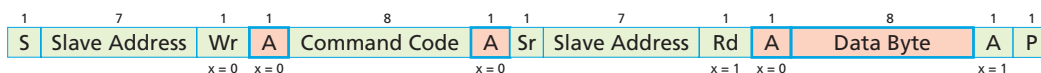

Figure 2 — ON\_OFF\_CONFIG COMMAND (02h), READ BYTE PROTOCOL



**Write Word protocol:**

When transmitting a word, the lowest order byte leads the highest order byte. Furthermore, when transmitting a Byte, the least significant bit (LSB) is sent last. Refer to System Management Bus (SMBus) specification version 2.0 for more details.

Note: Extended command and Packet Error Checking Protocols are not supported.

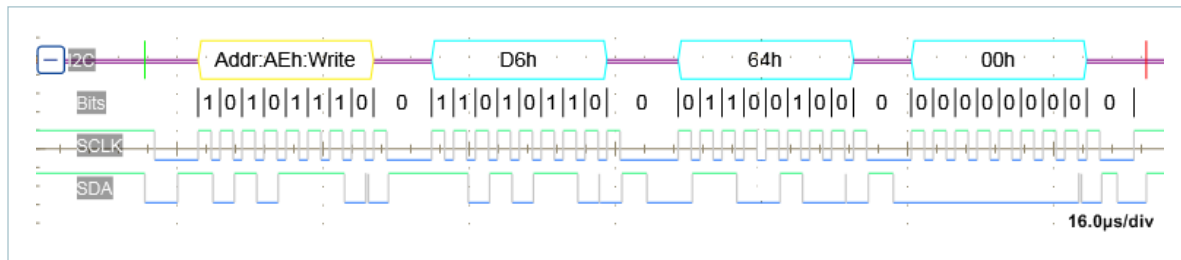
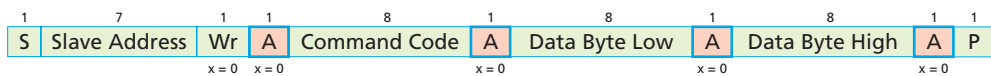

Figure 3 — TON\_DELAY COMMAND (60h)\_WRITE WORD PROTOCOL

**Read Word protocol:**

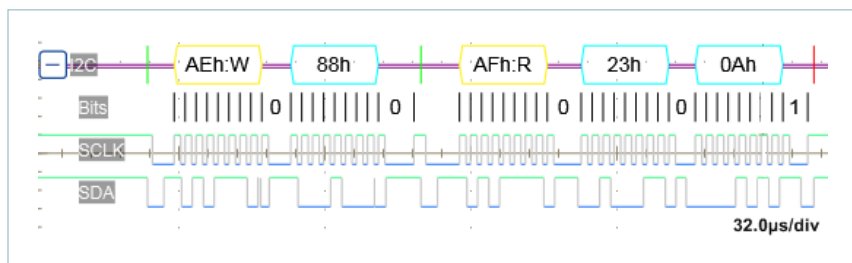
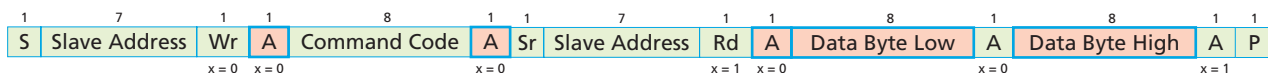

Figure 4 — MFR\_VIN\_MIN COMMAND (A0h)\_READ WORD PROTOCOL

**Write Block protocol:**

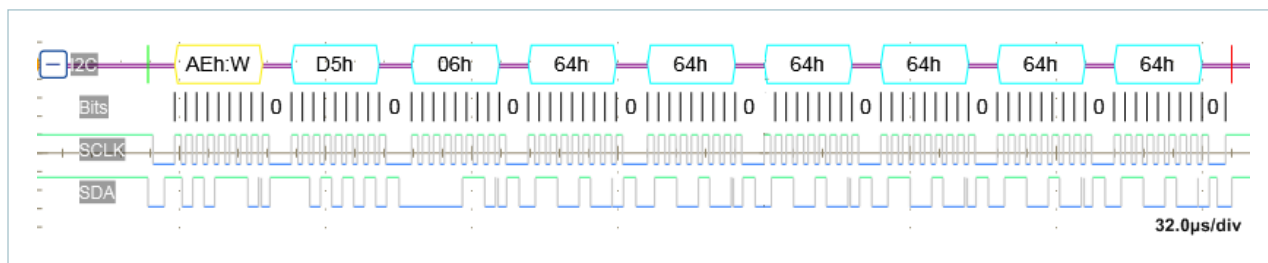
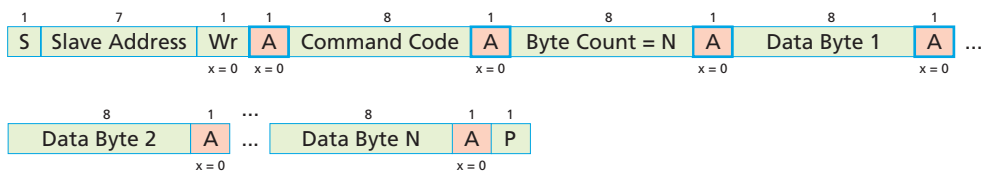

Figure 5 — SET\_ALL\_THRESHOLDS COMMAND (D5h)\_WRITE BLOCK PROTOCOL

**Read Block protocol:**

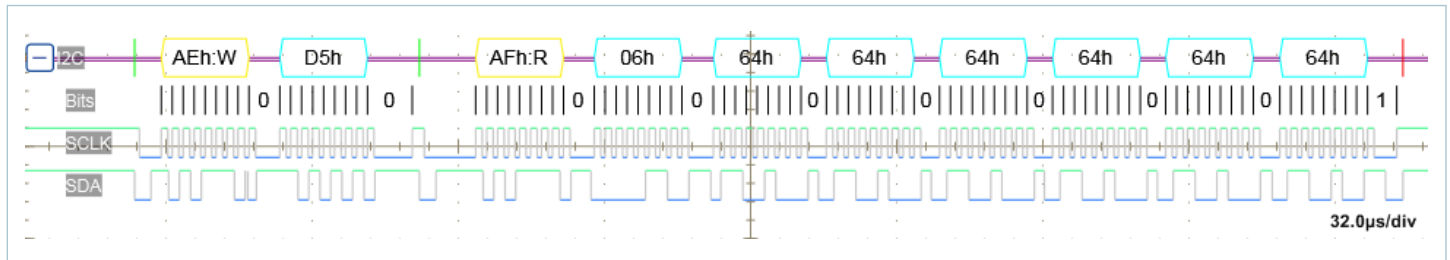
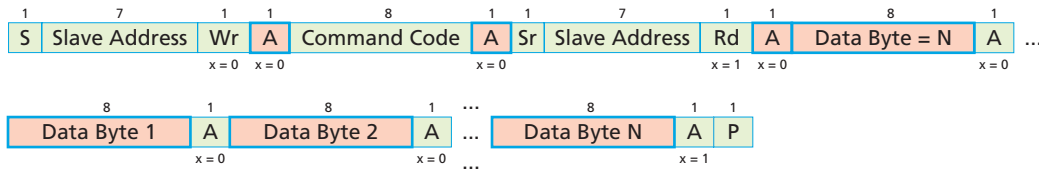

Figure 6 — SET\_ALL\_THRESHOLDS COMMAND (D5h)\_READ BLOCK PROTOCOL

**Write Group Command protocol:**

Note that only one command per device is allowed in a group command.

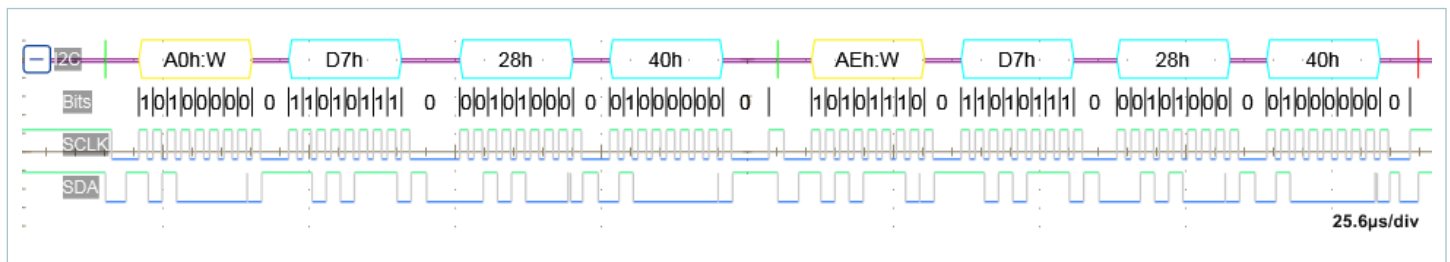
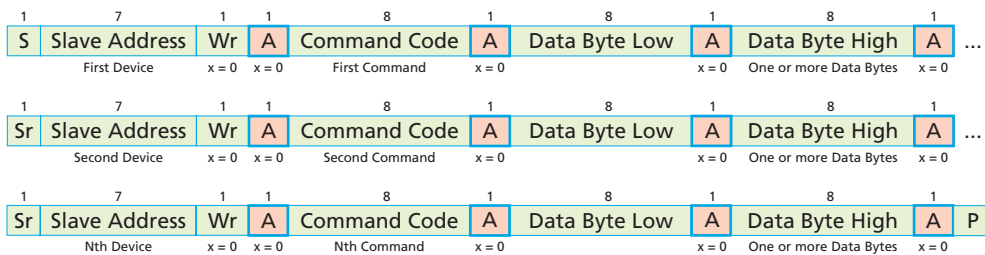

Figure 7 — DISABLE\_FAULT COMMAND (D7h)\_WRITE

### Supported Commands Transaction type

A direct communication to the BCM internal  $\mu$ C and a simulated communication to non-PMBus™ devices is enabled by a page command. Supported command access privileges with a pre-selected PAGE are defined in the following table. Deviation from this table generates a communication error in STATUS\_CML register.

Command	Code	PAGE Data Byte Access Type	
		00h	01h
PAGE	00h	R/W	R/W
OPERATION	01h	R	R/W
ON_OFF_CONFIG	02h		R
CLEAR_FAULTS	03h	W	W
CAPABILITY	19h	R	
OT_FAULT_LIMIT	4Fh		R/W
OT_WARN_LIMIT	51h		R/W
VIN_OV_FAULT_LIMIT	55h		R/W
VIN_OV_WARN_LIMIT	57h		R/W
IIN_OC_FAULT_LIMIT	5Bh		R/W
IIN_OC_WARN_LIMIT	5Dh		R/W
TON_DELAY	60h		R/W
STATUS_BYTE	78h	R/W	R
STATUS_WORD	79h	R	R
STATUS_IOUT	7Bh	R	R/W
STATUS_INPUT	7Ch	R	R/W
STATUS_TEMPERATURE	7Dh	R	R/W
STATUS_CML	7Eh	R/W	
STATUS_MFR_SPECIFIC	80h	R	R/W
READ_VIN	88h		R
READ_IIN	89h	R	R
READ_VOUT	8Bh		R
READ_IOUT	8Ch	R	R
READ_TEMPERATURE_1	8Dh	R	R
READ_POUT	96h	R	R
PMBUS_REVISION	98h	R	
MFR_ID	99h	R	
MFR_MODEL	9Ah	R	R
MFR_REVISION	9Bh	R	R
MFR_LOCATION	9Ch	R	R
MFR_DATE	9Dh	R	R
MFR_SERIAL	9Eh	R	R
MFR_VIN_MIN	A0h	R	R
MFR_VIN_MAX	A1h	R	R
MFR_VOUT_MIN	A4h	R	R
MFR_VOUT_MAX	A5h	R	R
MFR_IOUT_MAX	A6h	R	R
MFR_POUT_MAX	A7h	R	R
BCM_EN_POLARITY	D0h		R/W
READ_K_FACTOR	D1h		R
READ_BCM_ROUT	D4h		R
SET_ALL_THRESHOLDS	D5h		R/W
DISABLE_FAULT	D7h		R/W

### Page Command (00h)

The page command data byte of 00h prior to a command call will address the internal  $\mu$ C specific data and a page data byte of FFh would broadcast to all of the connected BCMs. The value of the Data Byte corresponds to the pin name trailing number with the exception of 00h and FFh.

Data Byte	Description
00h	$\mu$ C
01h	BCM

### OPERATION Command (01h)

The Operation command can be used to turn on and off the connected BCM. Note that the host OPERATION command will not enable the BCM if the BCM EN pin is disabled in hardware with respect to the pre set pin polarity. Only with the EN pin active, will the OPERATION command provide ON/OFF control.

If synchronous startup is required in the system, it is recommended to use the command from host PMBus in order to achieve simultaneous array startup.

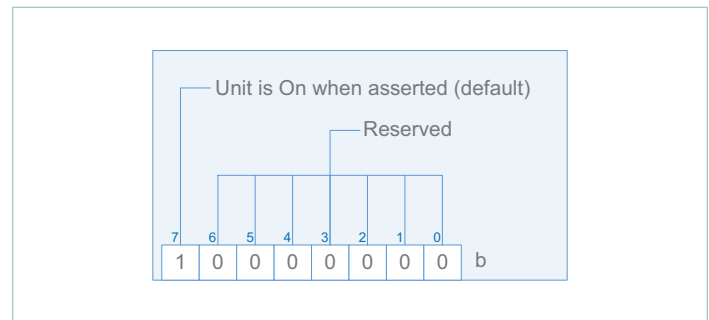

This command accepts only two data values: 00h and 80h. If any other value is sent the command will be rejected and a CML Data error will result.

### ON\_OFF\_CONFIG Command (02h)

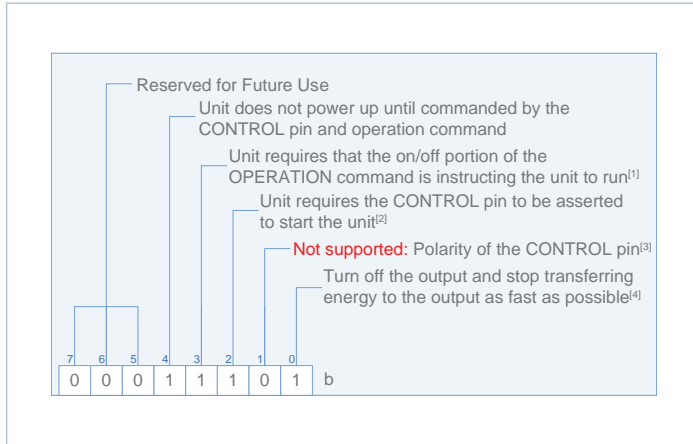

- [1] The BCM Enable pin is ALWAYS to be asserted for powerup. The BCM\_EN\_POLARITY command (D0h) bit(1) defines the logic level required for the control pin (i.e BCM Enable pin) to be asserted.
- [2] With respect to the BCM EN Control Pin if used in system
- [3] See MFR\_SPECIFIC\_00 / BCM\_EN\_POLARITY to change the Polarity of the BCM Enable Pin
- [4] The BCM powertrain once disabled cannot sink current

### CLEAR\_FAULTS Command (03h)

This command clears all status bits that have been previously set. Persistent or active faults are re asserted again once cleared. All faults are latched once asserted in the internal  $\mu$ C. Registered faults will not be cleared when shutting down the BCM powertrain by recycling the BCM high side voltage, or toggling the BCM EN pin, or sending the OPERATION command.

### CAPABILITY Command (19h)

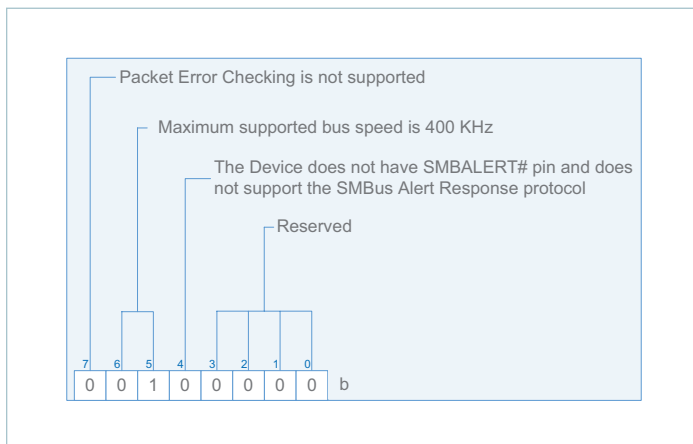

The internal  $\mu$ C returns a default value of 20h. This value indicates that the PMBus™ frequency supported is up to 400KHz and that both Packet Error Checking (PEC) and SMBALERT# are not supported.

- OT\_FAULT\_LIMIT Command (4Fh),
- OT\_WARN\_LIMIT Command (51h),
- VIN\_OV\_FAULT\_LIMIT Command (55h),
- VIN\_OV\_WARN\_LIMIT Command (57h),
- IIN\_OC\_FAULT\_LIMIT Command (5Bh),
- IIN\_OC\_WARN\_LIMIT Command (5Dh)

The values of these registers are set in non volatile memory and can only be written when the BCMs are disabled.

The values of the above mentioned fault and warning are set by default to a 100% of the respective BCM model supervisory limits. However these limits can be set to a lower value. For example: In order for a limit percentage to be set to 80% one would send a write command with a (50h) Data Word.

Any values outside the range of (00h – 64h) sent by a host will be rejected, will not override the currently stored value and will set the Unsupported Data bit in STATUS\_CML.

The SET\_ALL\_THRESHOLDS COMMAND (D5h) combines in one block over temperature fault and warning limits,  $V_{HI}$  overvoltage fault and warning limits as well as  $I_{LO}$  overcurrent fault and warning limits. A delay prior to a read command of up to 200ms following a write of new value is required.

The VIN\_UV\_WARN\_LIMIT (58h) and VIN\_UV\_FAULT\_LIMIT (59h) are set by the factory and cannot be changed by the host. However, a host can disable the under voltage setting using the DISABLE\_FAULT COMMAND (D7h).

All FAULT\_RESPONSE commands are unsupported. The BCM powertrain supervisory limits and powertrain protection will behave as described in the BCM datasheet. In general, once a fault is detected, the BCM powertrain will shut down and attempt to auto restart after a predetermined delay.

### TON\_DELAY Command (60h)

The value of this register word is set in non volatile memory and can only be written when the BCMs are disabled.

The maximum possible delay is 100ms. Default value is set to (00h). Follow this equation below to interpret the reported value.

$$TON\_DELAY_{ACTUAL} = t_{REPORTED} \cdot 10^{-3}(s)$$

Staggering startup in an array is possible with TON\_DELAY Command. This delay will be in addition to any startup delay inherent in the BCM module. For example: startup delay from application of  $V_{HI}$  is typically 20ms whereas startup with EN pin is typically 250 $\mu$ s. When TON\_DELAY is greater than zero, the set delay will be added to both.

STATUS\_BYTE (78h) and STATUS\_WORD (79h)

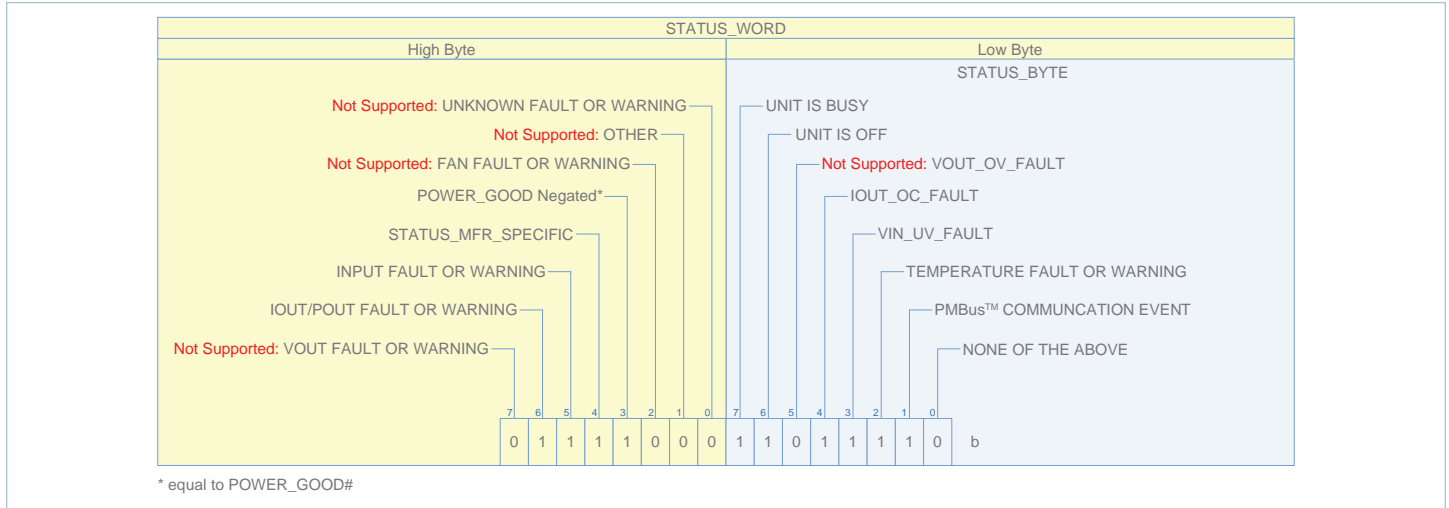

All fault or warning flags, if set, will remain asserted until cleared by the host or once the internal  $\mu$ C power is removed. This includes under voltage fault, overvoltage fault, overvoltage warning, overcurrent warning, over temperature fault, over temperature warning, under temperature fault, reverse operation, communication faults and analog controller shutdown fault.

Asserted status bits in all status registers, with the exception of STATUS\_WORD and STATUS\_BYTE, can be individually cleared. This is done by sending a data byte with one in the bit position corresponding to the intended warning or fault to be cleared. Refer to the PMBus™ Power System Management Protocol Specification – Part II – Revision 1.2 for details.

The POWER\_GOOD# bit reflects the state of the device and does not reflect the state of the POWER\_GOOD# signal limits. The POWER\_GOOD\_ON COMMAND (5Eh) and POWER\_GOOD\_OFF COMMAND (5Fh) are not supported. The POWER\_GOOD# bit is set anytime the BCM is not in the enabled state, to indicate that the powertrain is inactive and not switching. The POWER\_GOOD# bit is cleared when the BCM completes the enabling state, 5 ms after the powertrain is activated allowing for soft start to elapse. POWER\_GOOD# and OFF bits cannot be cleared as they always reflect the current state of the device.

When Page (00h) is used the POWER\_GOOD# bit reflects the OR-ing of all active BCMs' POWER\_GOOD# bits. When Page (01h – 04h) is used POWER\_GOOD# is clear only when the BCM is active.

When Page (00h) is used UNIT IS OFF is SET when all BCMs are not active. When Page (01h – 04h) is used UNIT IS OFF is clear only when the BCM is active.

The Busy bit can be cleared using CLEAR\_ALL Command (03h) or by writing either data value (40h, 80h) to PAGE (00h) using the STATUS\_BYTE (78h).

Fault reporting, such as SMBALERT# signal output, and host notification by temporarily acquiring bus master status is not supported.

If the internal  $\mu$ C is still powered, it will retain the last status it received from the BCM and this information will be available to the user via a PMBus Status request. This is in agreement with the PMBus standard which requires that status bits remain set until specifically cleared. Note that in this case where the BCM  $V_{HI}$  is lost, the status will always indicate an under voltage fault, in addition to any other fault that occurred.

NONE OF THE ABOVE bit will be asserted if either the STATUS\_MFR\_SPECIFIC (80h) or the High Byte of the STATUS WORD is set.

STATUS\_IOUT (7Bh)

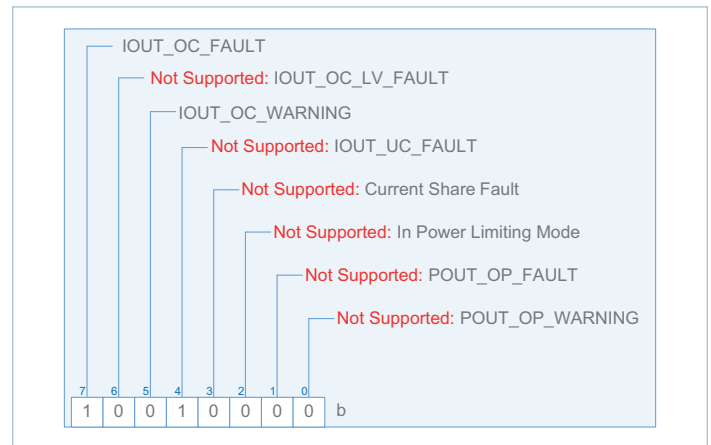

Unsupported bits are indicated above. A one indicates a fault.

### STATUS\_INPUT (7Ch)

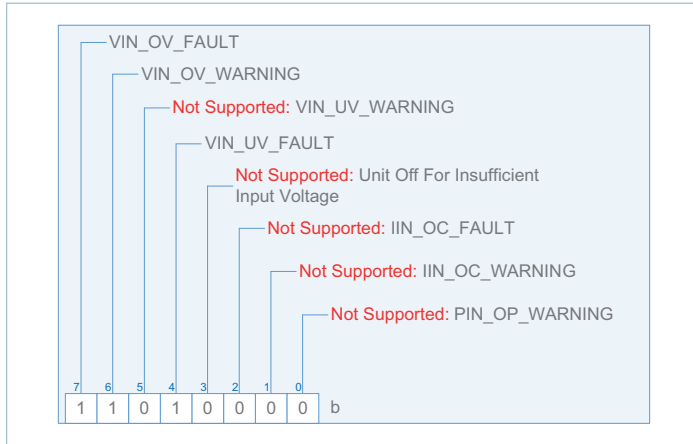

Unsupported bits are indicated above. A one indicates a fault.

### STATUS\_TEMPERATURE (7Dh)

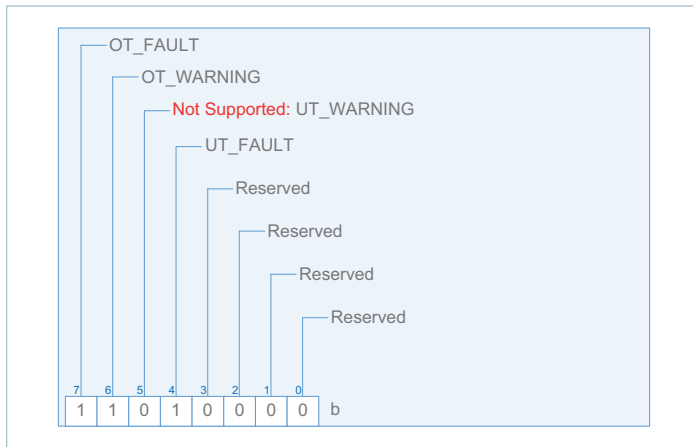

Unsupported bits are indicated above. A one indicates a fault.

### STATUS\_CML (7Eh)

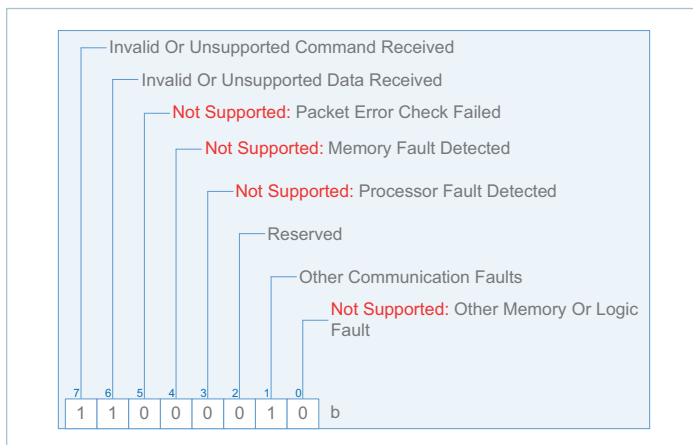

Unsupported bits are indicated above. A one indicates a fault.

The STATUS\_CML data byte will be asserted when an unsupported PMBus™ command or data or other communication fault occurred.

### STATUS\_MFR\_SPECIFIC (80h)

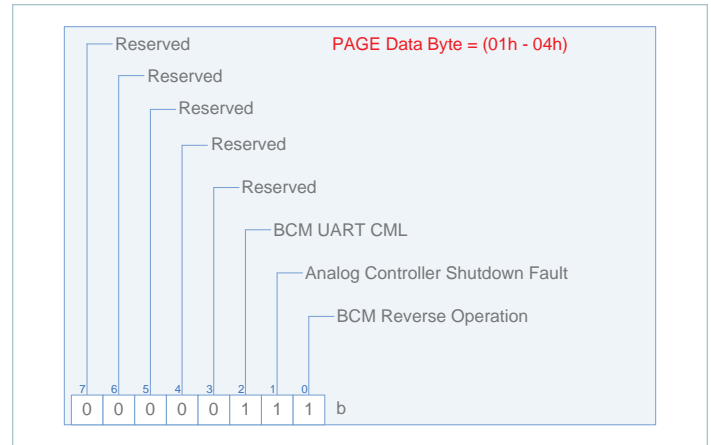

The reverse operation bit, if asserted, indicates that the BCM is processing current in reverse. Reverse current reported value is not supported.

The BCM has analog protections and internal μC protections. The analog controller provides an additional layer of protection and has the fastest response time. The analog controller shutdown fault, when asserted, indicates that at least one of the powertrain protection faults is triggered. This fault will also be asserted if a disabled fault event occurs after asserting any bit using the DISABLE\_FAULTS COMMAND.

The BCM UART is designed to operate with the internal μC UART. If the BCM UART CML is asserted, it may indicate a hardware or connection issue between both devices.

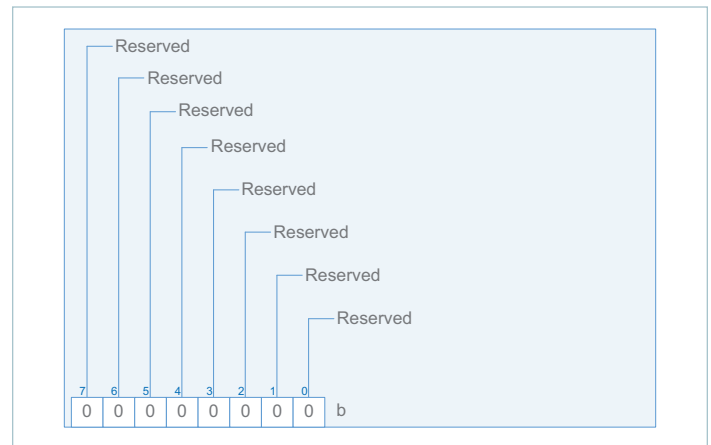

When PAGE COMMAND (00h) data byte is equal to (00h), the BCM Reverse operation, Analog Controller Shutdown Fault, and BCM UART CML bit will return OR-ing result of active BCMs. The BCM UART CML will also be asserted if any of the active BCMs stops responding. The BCM must communicate at least once to the internal μC in order to trigger this FAULT. The BCM UART CML can be cleared from the culprit BCM once the internal μC is able to communicate with it once again or can be cleared using PAGE (00h) CLEAR\_FAULTS (03h) Command.

### READ\_VIN Command (88h)

If PAGE data byte is equal to (01h - 04h) command will return a reported individual BCM's HI side voltage in the following format:

$$V_{HI\_ACTUAL} = V_{HI\_REPORTED} \cdot 10^{-1}(V)$$

### READ\_IIN Command (89h)

If PAGE data byte is equal to (01h - 04h) command will return a reported individual BCM's HI side current in the following format:

$$I_{HI\_ACTUAL} = I_{HI\_REPORTED} \cdot 10^{-3}(A)$$

If PAGE data byte is equal (00h) command will return the sum of active BCM's HI side current.

### READ\_VOUT Command (8Bh)

If PAGE data byte is equal to (01h - 04h) command will return a reported individual BCM's LO side voltage in the following format:

$$V_{LO\_ACTUAL} = V_{LO\_REPORTED} \cdot 10^{-1}(V)$$

### READ\_IOUT Command (8Ch)

If PAGE data byte is equal to (01h - 04h) command will return a reported individual BCM's LO side current in the following format:

$$I_{LO\_ACTUAL} = I_{LO\_REPORTED} \cdot 10^{-2}(A)$$

If PAGE data byte is equal (00h) command will return the sum of active BCM's LO side current.

### READ\_TEMPERATURE\_1 Command (8Dh)

If PAGE data byte is equal to (01h - 04h) command will return a reported individual BCM's temperature in the following format:

$$T_{ACTUAL} = \pm T_{REPORTED} (^{\circ}C)$$

If PAGE data byte is equal (00h) command will return the maximum temperature of active BCM's.

### READ\_POOUT Command (96h)

If PAGE data byte is equal to (01h - 04h) command will return a reported individual BCM's LO side power in the following format:

$$P_{LO\_ACTUAL} = P_{LO\_REPORTED} (W)$$

If PAGE data byte is equal to (00h) command will return the sum of active BCM's LO side power.

### MFR\_VIN\_MIN Command (A0h), MFR\_VIN\_MAX Command (A1h), MFR\_VOUT\_MIN Command (A4h), MFR\_VOUT\_MAX Command (A5h), MFR\_IOUT\_MAX Command (A6h), MFR\_POOUT\_MAX Command (A7h)

These values are set by the factory and indicate the device HI side/ LO side voltage and LO side current range and LO side power capacity.

The internal  $\mu$ C will report rated BCM HI side voltage minimum and maximum in Volts, LO side voltage minimum and maximum in Volts, LO side current maximum in Amperes and LO side power maximum in Watts.

If PAGE data byte is equal to (00h) then:

- MFR\_VIN\_MIN COMMAND (A0h) will return the highest MFR\_VIN\_MIN of all active BCMs
- MFR\_VIN\_MAX COMMAND (A1h) will return the lowest MFR\_VIN\_MAX of all active BCMs
- MFR\_VOUT\_MIN COMMAND (A4h) will return the highest MFR\_VOUT\_MIN of all active BCMs
- MFR\_VOUT\_MAX COMMAND (A5h) will return the lowest MFR\_VOUT\_MAX of all active BCMs
- MFR\_IOUT\_MAX COMMAND (A6h) will return the SUM of MFR\_IOUT\_MAX of all active BCMs
- MFR\_POOUT\_MAX COMMAND (A7h) will return the SUM of MFR\_POOUT\_MAX of all active BCMs

**BCM\_EN\_POLARITY Command (D0h)**

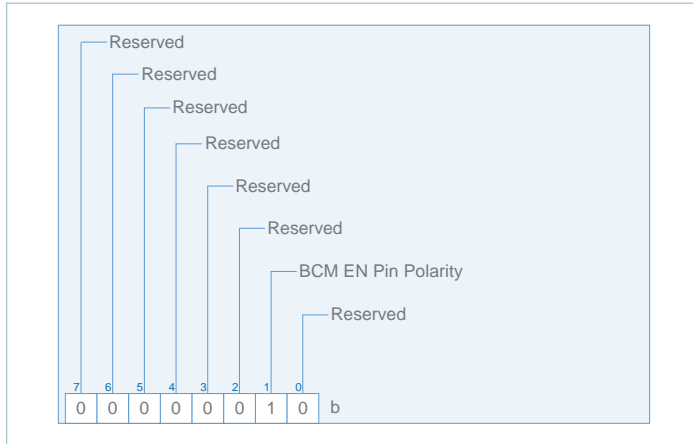

The value of this register is set in non volatile memory and can only be written when the BCMs are disabled.

When PAGE COMMAND (00h) data byte is equal to (01h – 04h), this command defines the polarity of the EN pin. If BCM\_EN\_POLARITY is set, the BCM will startup once V<sub>HI</sub> is greater than the under voltage threshold.

The BCM EN PIN is internally pulled-up to 3.3V. If the BCM\_EN\_POLARITY is cleared, an external pull-down is then required. Applying V<sub>HI</sub> greater than the under voltage threshold will not suffice to start the BCM.

**READ\_K\_FACTOR Command (D1h)**

If PAGE data byte is equal to (01h - 04h) command will return a reported individual BCMs K factor in the following format:

$$K\_FACTOR_{ACTUAL} = K\_FACTOR_{REPORTED} \cdot 2^{-16}(V/V)$$

The K factor is defined in a BCM to represent the ratio of the transformer winding and hence is equal to V<sub>LO</sub> / V<sub>HI</sub>.

**READ\_BCM\_ROUT Command (D4h)**

If PAGE data byte is equal to (01h - 04h) command will return a reported individual BCM's LO side resistance in the following format:

$$BCM\_R_{LO\_ACTUAL} = BCM\_R_{LO\_REPORTED} \cdot 10^{-5}(\Omega)$$

**SET\_ALL\_THRESHOLDS Command (D5h)**

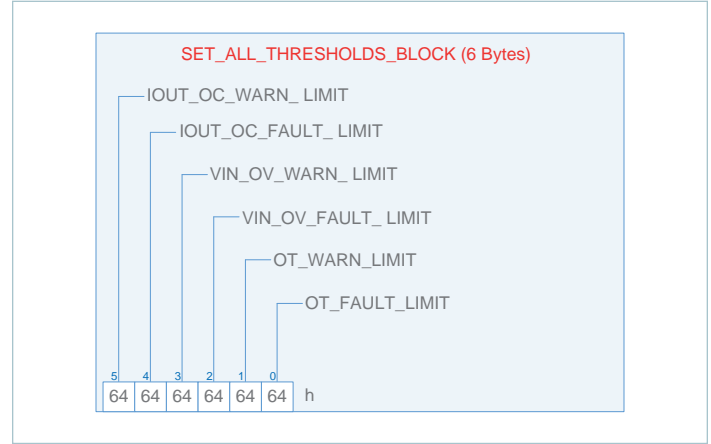

Values of this register block is set in non volatile memory and can only be written when the BCMs are disabled.

This command provides a convenient way to configure all the limits, or any combination of limits described previously using one command.

V<sub>HI</sub> Overvoltage, Overcurrent and Overtemperature values are all set to 100% of the BCM datasheet supervisory limits by default and can only be set to a lower percentage.

To leave a particular threshold unchanged, set the corresponding threshold data byte to a value greater than (64h).

**DISABLE\_FAULT Command (D7h)**

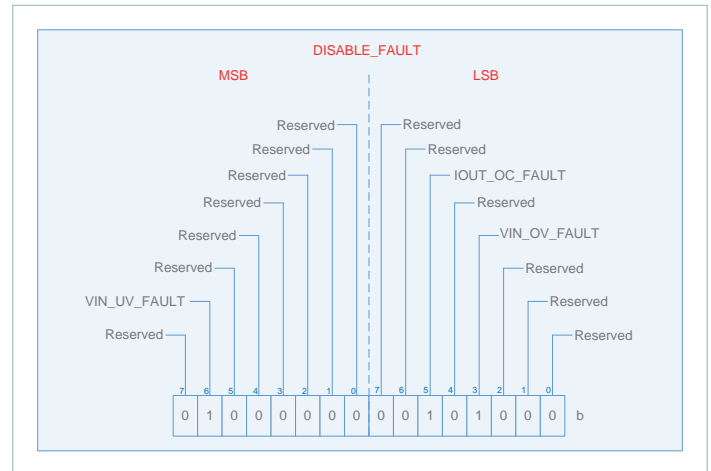

Unsupported bits are indicated above. A one indicates that the supervisory fault associated with the asserted bit is disabled.

The value of these registers is set in non volatile memory and can only be written when the BCMs are disabled.

This command allows the host to disable the supervisory faults and respective statuses. It does not disable the powertrain analog protections or warnings with respect to the set limits in the SET\_ALL\_THRESHOLDS Command.

The HI side undervoltage can only be disabled to a pre set low limit as shown in the functional reporting range in the BCM data sheet.



## The internal $\mu$ C Implementation vs. PMBus™ Specification Rev 1.2

The internal  $\mu$ C is an I<sup>2</sup>C compliant, SMBus™ compatible device and PMBus command compliant device. This section denotes some deviation, perceived as differences from the PMBus Part I and Part II specification Rev 1.2.

1. The internal  $\mu$ C meets all Part I and II PMBus specification requirements with the following differences to the transport requirement.

Unmet DC parameter Implementation vs SMBus™ spec						
Symbol	Parameter	D44TL1A0		SMBus™ Rev 2.0		Units
		Min	Max	Min	Max	
V <sub>IL</sub> <sup>[a]</sup>	Input Low Voltage	-	0.99	-	0.8	V
V <sub>IH</sub> <sup>[a]</sup>	Input High Voltage	2.31	-	2.1	V <sub>VDD_IN</sub>	V
I <sub>LEAK_PIN</sub> <sup>[b]</sup>	Input Leakage per Pin	10	22	-	±5	μA

<sup>[a]</sup> V<sub>VDD\_IN</sub> = 3.3V

<sup>[b]</sup> V<sub>BUS</sub> = 5V

2. The internal  $\mu$ C accepts 38 PMBus command codes. Implemented commands execute functions as described in the PMBus specification.
  - Deviations from the PMBus specification:
    - a. Section 15, fault related commands
      - The limits and Warnings unit implemented is percentage (%) a range from decimal (0-100) of the factory set limits.

3. The internal  $\mu$ C unsupported PMBus command code response as described in the Fault Management and Reporting:
  - Deviations from the PMBus specification:
    - a. PMBus section 10.2.5.3, exceptions
      - The busy bit of the STATUS\_BYTE as implemented can be cleared (80h). In order to maintain compatibility with the specification (40h) can also be used.
    - Manufacturer Implementation of the PMBus Spec
      - a. PMBus section 10.5, setting the response to a detected fault condition
        - All powertrain responses are pre-set and cannot be changed. Refer to the BCM datasheet for details.
      - b. PMBus section 10.6, reporting faults and warnings to the Host
        - SMBALERT# signal and Direct PMBus Device to Host Communication are not supported. However, the Digital Supervisor will set the corresponding fault status bits and will wait for the host to poll.
      - c. PMBus section 10.7, clearing a shutdown due to a fault
        - There is no RESET pin or EN pin in the internal  $\mu$ C. Cycling power to the internal  $\mu$ C will not clear a BCM Shutdown. The BCM will clear itself once the fault condition is removed. Refer to the BCM datasheet for details.
      - d. PMBus Section 10.8.1, corrupted data transmission faults:
        - Packet error checking is not supported.

## Data Transmission Faults Implementation

This section describes data transmission faults as implemented in the internal  $\mu$ C.

Section	Description	Response to Host		STATUS_BYTE	STATUS_CML		Notes
		NAK	FFh	CML	Other Fault	Unsupported Data	
10.8.1	Corrupted data						No response; PEC not supported
10.8.2	Sending too few bits			X	X		
10.8.3	Reading too few bits			X	X		
10.8.4	Host sends or reads too few bytes			X	X		
10.8.5	Host sends too many bytes	X		X		X	
10.8.6	Reading too many bytes		X	X	X		
10.8.7	Device busy	X	X				Device will ACK own address BUSY bit in STATUS_BYTE even if STATUS_WORD is set

## Data Content Faults Implementation

This section describes data content fault as implemented in the internal  $\mu$ C.

Section	Description	Response to Host	STATUS_BYTE	STATUS_CML			Notes
		NAK	CML	Other Fault	Unsupported Command	Unsupported Data	
10.9.1	Improperly Set Read Bit In The Address Byte	X	X	X			
10.9.2	Unsupported Command Code	X	X		X		
10.9.3	Invalid or Unsupported Data		X			X	
10.9.4	Data Out of Range		X			X	
10.9.5	Reserved Bits						No response; not a fault

BCM in VIA Package Chassis (Lug) Mount Package Mechanical Drawing

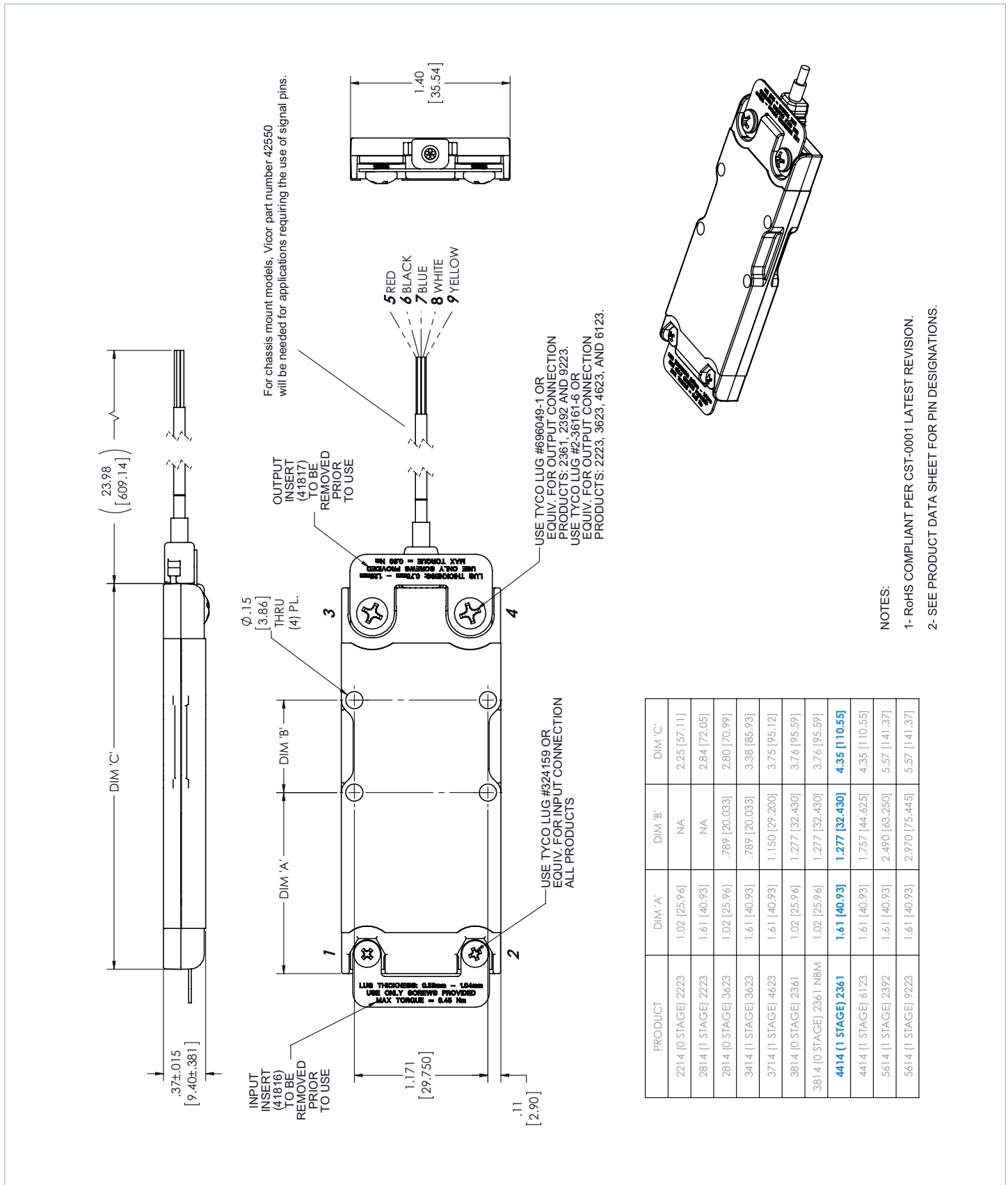

## BCM in VIA Package PCB (Board) Mount Package Mechanical Drawing and Recommended Hole Pattern

PRODUCT	DIM 'A'	DIM 'B'	DIM 'C'	DIM 'D'	DIM 'E'	DIM 'F'	DIM 'G'
3814 (0 STAGE) 2361	1.02 [25.94]	1.277 [32.430]	3.76 [95.59]	3.368 [85.554]	3.85 [97.80]	.850 [21.590]	3.432 [92.243]
3814 (0 STAGE) 2361 NBM	1.02 [25.94]	1.277 [32.430]	3.76 [95.59]	3.368 [85.554]	3.85 [97.80]	.850 [21.590]	3.432 [92.243]
<b>4414 (1 STAGE) 2361</b>	<b>1.61 [40.93]</b>	<b>1.277 [32.430]</b>	<b>4.36 [110.59]</b>	<b>3.957 [100.517]</b>	<b>4.44 [112.76]</b>	<b>1.439 [36.553]</b>	<b>4.221 [107.206]</b>
5614 (1 STAGE) 2392	1.61 [40.93]	2.490 [63.250]	5.57 [141.37]	5.171 [131.337]	5.65 [143.58]	1.439 [36.553]	5.434 [138.026]

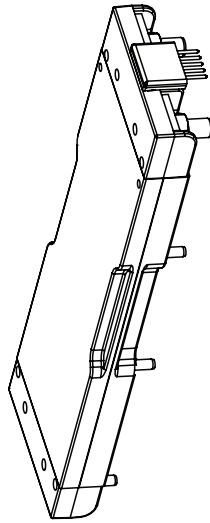

- NOTES:
- 1- ROHS COMPLIANT PER CST-0001 LATEST REVISION.
  - 2- SEE PRODUCT DATA SHEET FOR PIN DESIGNATIONS.

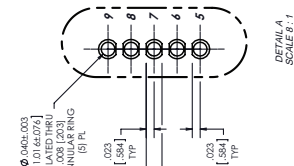
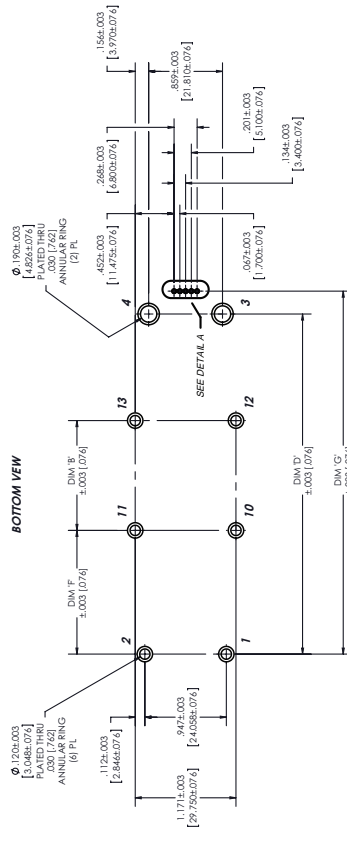
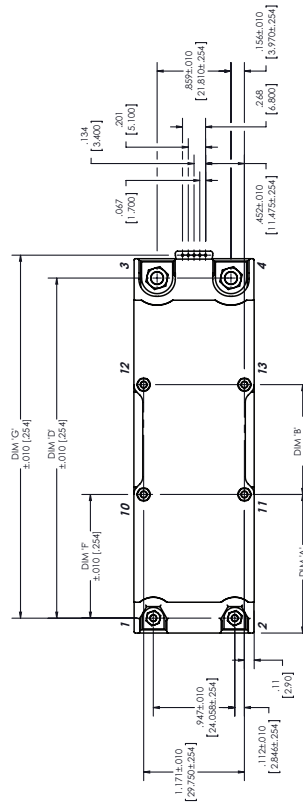
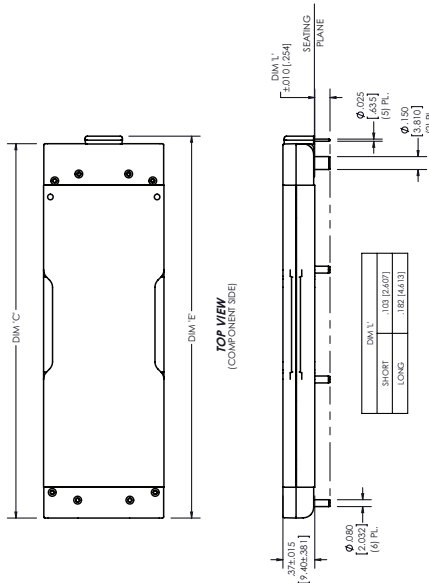

DETAIL A  
SCALE 8 : 1

Revision History

Revision	Date	Description	Page Number(s)
1.0	03/3/16	Initial release	n/a
1.1	05/2/16	New Power Pin Nomenclature	All

**Vicor's comprehensive line of power solutions includes high density AC-DC and DC-DC modules and accessory components, fully configurable AC-DC and DC-DC power supplies, and complete custom power systems.**

Information furnished by Vicor is believed to be accurate and reliable. However, no responsibility is assumed by Vicor for its use. Vicor makes no representations or warranties with respect to the accuracy or completeness of the contents of this publication. Vicor reserves the right to make changes to any products, specifications, and product descriptions at any time without notice. Information published by Vicor has been checked and is believed to be accurate at the time it was printed; however, Vicor assumes no responsibility for inaccuracies. Testing and other quality controls are used to the extent Vicor deems necessary to support Vicor's product warranty. Except where mandated by government requirements, testing of all parameters of each product is not necessarily performed.

**Specifications are subject to change without notice.**

### **Vicor's Standard Terms and Conditions**

All sales are subject to Vicor's Standard Terms and Conditions of Sale, which are available on Vicor's webpage or upon request.

### **Product Warranty**

In Vicor's standard terms and conditions of sale, Vicor warrants that its products are free from non-conformity to its Standard Specifications (the "Express Limited Warranty"). This warranty is extended only to the original Buyer for the period expiring two (2) years after the date of shipment and is not transferable.

UNLESS OTHERWISE EXPRESSLY STATED IN A WRITTEN SALES AGREEMENT SIGNED BY A DULY AUTHORIZED VICOR SIGNATORY, VICOR DISCLAIMS ALL REPRESENTATIONS, LIABILITIES, AND WARRANTIES OF ANY KIND (WHETHER ARISING BY IMPLICATION OR BY OPERATION OF LAW) WITH RESPECT TO THE PRODUCTS, INCLUDING, WITHOUT LIMITATION, ANY WARRANTIES OR REPRESENTATIONS AS TO MERCHANTABILITY, FITNESS FOR PARTICULAR PURPOSE, INFRINGEMENT OF ANY PATENT, COPYRIGHT, OR OTHER INTELLECTUAL PROPERTY RIGHT, OR ANY OTHER MATTER.

This warranty does not extend to products subjected to misuse, accident, or improper application, maintenance, or storage. Vicor shall not be liable for collateral or consequential damage. Vicor disclaims any and all liability arising out of the application or use of any product or circuit and assumes no liability for applications assistance or buyer product design. Buyers are responsible for their products and applications using Vicor products and components. Prior to using or distributing any products that include Vicor components, buyers should provide adequate design, testing and operating safeguards.

Vicor will repair or replace defective products in accordance with its own best judgment. For service under this warranty, the buyer must contact Vicor to obtain a Return Material Authorization (RMA) number and shipping instructions. Products returned without prior authorization will be returned to the buyer. The buyer will pay all charges incurred in returning the product to the factory. Vicor will pay all reshipment charges if the product was defective within the terms of this warranty.

### **Life Support Policy**

VICOR'S PRODUCTS ARE NOT AUTHORIZED FOR USE AS CRITICAL COMPONENTS IN LIFE SUPPORT DEVICES OR SYSTEMS WITHOUT THE EXPRESS PRIOR WRITTEN APPROVAL OF THE CHIEF EXECUTIVE OFFICER AND GENERAL COUNSEL OF VICOR CORPORATION. As used herein, life support devices or systems are devices which (a) are intended for surgical implant into the body, or (b) support or sustain life and whose failure to perform when properly used in accordance with instructions for use provided in the labeling can be reasonably expected to result in a significant injury to the user. A critical component is any component in a life support device or system whose failure to perform can be reasonably expected to cause the failure of the life support device or system or to affect its safety or effectiveness. Per Vicor Terms and Conditions of Sale, the user of Vicor products and components in life support applications assumes all risks of such use and indemnifies Vicor against all liability and damages.

### **Intellectual Property Notice**

Vicor and its subsidiaries own Intellectual Property (including issued U.S. and Foreign Patents and pending patent applications) relating to the products described in this data sheet. No license, whether express, implied, or arising by estoppel or otherwise, to any intellectual property rights is granted by this document. Interested parties should contact Vicor's Intellectual Property Department.

The products described on this data sheet are protected by the following U.S. Patents Pending

#### **Vicor Corporation**

25 Frontage Road  
Andover, MA, USA 01810  
Tel: 800-735-6200  
Fax: 978-475-6715

#### **email**

Customer Service: [custserv@vicorpower.com](mailto:custserv@vicorpower.com)  
Technical Support: [apps@vicorpower.com](mailto:apps@vicorpower.com)