

OV9712-1D ^{720p} HD video image sensor product brief



The OV9712-1D Offers Best-in-Class 720p HD Video Performance at 30 Frames Per Second (fps)



available in
a lead-free
package

Enabled by OmniVision's proprietary OmniPixel3-HS™ high sensitivity pixel technology with $3 \times 3 \mu\text{m}$ pixel and low-light sensitivity of 3.7 V/lux-sec, the OV9712-1D provides vivid imaging in virtually every lighting condition from bright daylight to nearly complete darkness. OV9712-1D has been re-optimized to improve QE, sensitivity and SNR.

The 1/4-inch OV9712-1D sensor provides full-frame, sub-sampled or windowed 8-bit/10-bit images in raw RGB format via the digital video port and with complete user control over image quality, formatting and output data transfer. The OV9712-1D offers a chief ray angle (CRA) of 25°.

The OV9712-1D incorporates advanced image processing functions, including exposure control, gain control, white balance, lens correction and defective pixel correction, programmable through the serial camera control bus (SCCB) interface. For storage purposes, it includes one-time programmable (OTP) memory.

The OV9712-1D is available in a CSP2 package and is capable of operating within a temperature range of -30°C to +70°C.

Find out more at www.ovt.com.

Applications

- Security
- Car DVR
- Notebooks
- Telepresence
- Mobile Phones
- Digital Still Cameras
- Webcams
- Medical
- Entertainment

Product Features

- high sensitivity for low-light operation
- ultra low power and low cost
- automatic image control functions:
 - automatic exposure control (AEC)
 - automatic gain control (AGC)
 - automatic white balance (AWB)
 - automatic band filter (ABF)
 - automatic black level calibration (ABLC)
- programmable controls: frame rate, AEC/AGC 16-zone size/position/weight control, mirror, flip and windowing
- image quality controls: lens correction and defective pixel canceling
- output support for raw RGB
- supports image sizes: WXGA (1280x800) and 640x400
- support for horizontal and vertical sub-sampling
- support for black sun cancellation
- standard serial camera control bus (SCCB) interface
- digital video port (DVP) parallel output interface
- embedded one-time programmable (OTP) memory
- on-chip phase lock loop (PLL)
- built-in 1.5V regulator for core

OV9712-1D

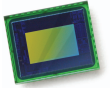

Ordering Information

- **OV09712-1D-V28A**
(color, lead-free, 28-pin CSP2)
- **OV09712-1D-G04A**
(color, chip probing, 200 μ m backgrinding, reconstructed wafer)
- **OV09211-V28A**
(B&W, lead-free, 28-pin CSP2)
- **OV09211-G04A**
(B&W, chip probing, 200 μ m backgrinding, reconstructed wafer)

Product Specifications

- **active array size:** 1280 x 800
- **power supply:**
 - core: 1.5 VDC \pm 5% (built-in regulator)
 - analog: 3.0 - 3.6 V
 - I/O: 1.7 - 3.6 V
- **power requirements:**
 - active: 110 mW
 - standby: 50 μ A
- **temperature range:**
 - operating: -30°C to 70°C junction temperature
 - stable image: 0°C to 50°C junction temperature
- **output formats (10-bit):** raw RGB data
- **lens size:** 1/4"
- **lens chief ray angle:** 25° non-linear
- **input clock frequency:** 6 - 27 MHz
- **scan mode:** progressive
- **maximum image transfer rate:**
 - WXGA (1280x800): 30 fps
 - HD 720p (1280x720): 30 fps
 - VGA (640x480): 60 fps
- **sensitivity:** 3700 mV/lux-sec
- **max S/N ratio:** 40 dB
- **dynamic range:** 69 dB @ 8x gain
- **maximum exposure interval:** 826 x t_{ROW}
- **pixel size:** 3 μ m x 3 μ m
- **dark current:** 20 mV/sec @ 60°C junction temperature
- **image area:** 3888 μ m x 2430 μ m
- **package/die dimensions:**
 - CSP2: 5415 μ m x 4415 μ m
 - COB: 5430 μ m x 4430 μ m

Functional Block Diagram

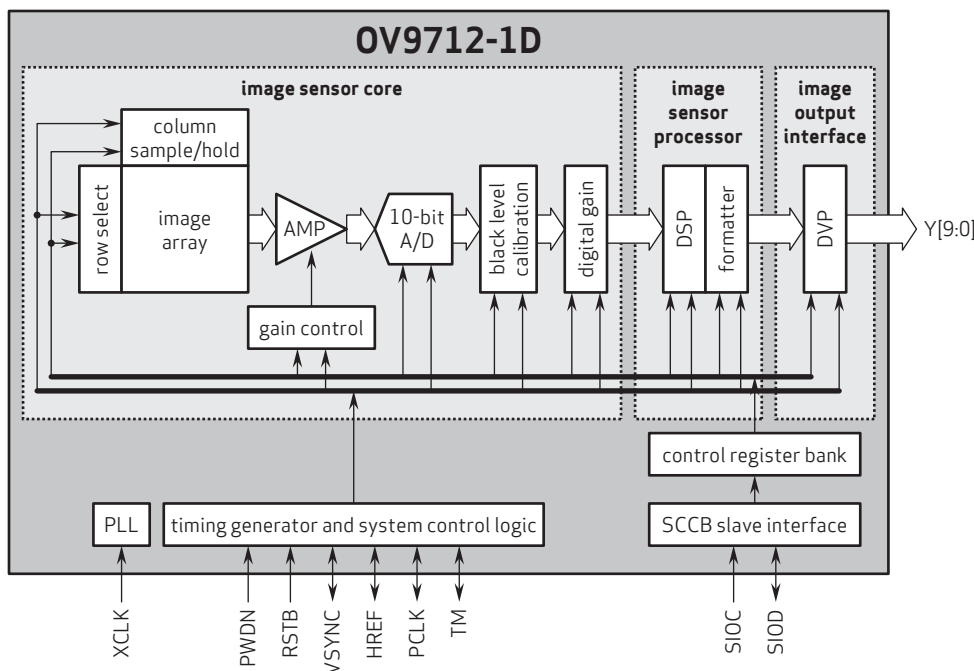

4275 Burton Drive
Santa Clara, CA 95054
USA

Tel: +1 408 567 3000
Fax: +1 408 567 3001
www.ovt.com

OmniVision reserves the right to make changes to their products or to discontinue any product or service without further notice. OmniVision and OmniPixel are registered trademarks of OmniVision Technologies, Inc. The OmniVision logo and OmniPixel3-HS are trademarks of OmniVision Technologies, Inc. All other trademarks are the property of their respective owners.