

Features

- Wide supply voltage range (3.5 - 13 V)
- Minimum external components
 - No SWR capacitor
 - No bootstrap
 - No Boucherot cells
 - Internally fixed gain
- Standby & mute functions
- Short-circuit protection
- Thermal overload protection

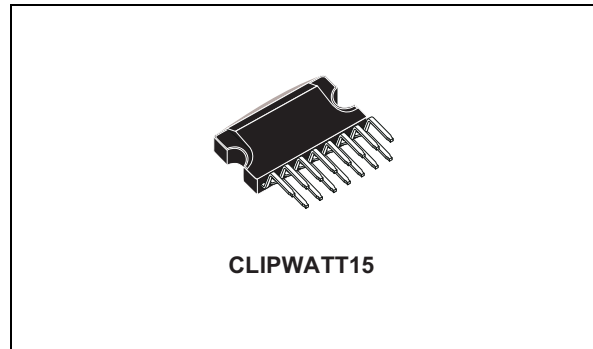

Description

The TDA7266SAN is a dual bridge amplifier specifically designed for LCD monitors, PC motherboards, TVs and portable radio applications.

The device is pin-to-pin compatible with the TDA7266, TDA7266SA, TDA7297SA and TDA7297.

Table 1. Device summary

Part number	Package	Packing
TDA7266SAN	Clipwatt15	Tube

Contents

1	Block diagram and pin connections	3
2	Electrical specifications	4
2.1	Absolute maximum ratings	4
2.2	Thermal data	4
3	Electrical characteristics	5
4	Application suggestions	6
	Standby and mute functions	6
4.1	Microprocessor application	6
4.2	Low-cost application	8
5	Characterization curves	9
6	PCB layout	10
7	Heatsink dimensioning	11
8	Package mechanical data	12
9	Revision history	14

1 Block diagram and pin connections

Figure 1. Block and application diagram

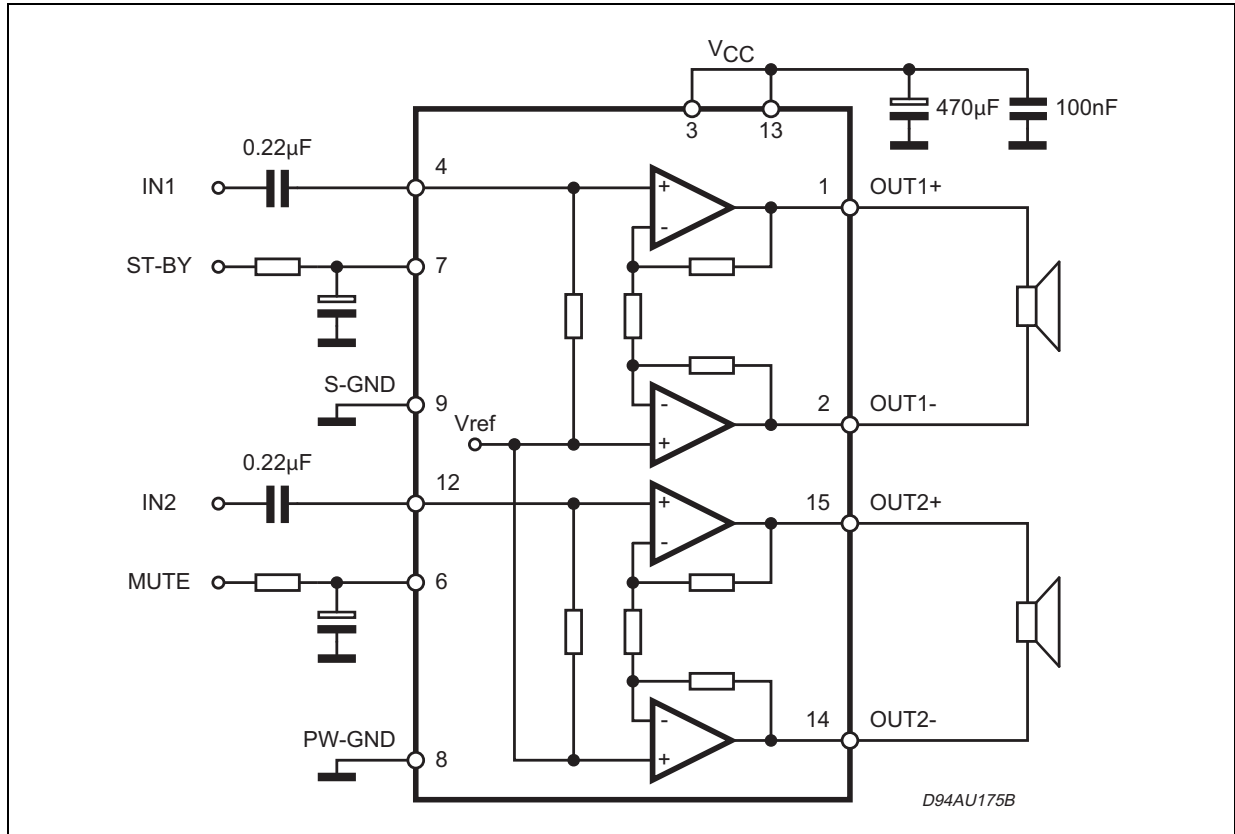
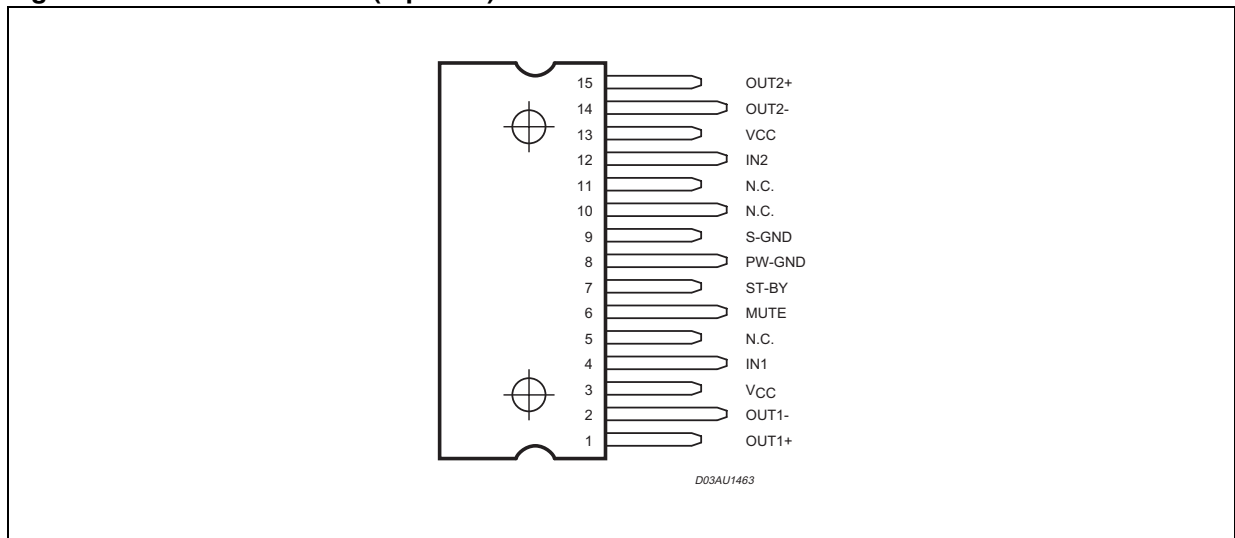

Figure 2. Pin connections (top view)



2 Electrical specifications

2.1 Absolute maximum ratings

Table 2. Absolute maximum ratings

Symbol	Parameter	Value	Unit
V_S	Supply voltage	13	V
I_O	Output peak current (internally limited)	2	A
P_{tot}	Total power dissipation ($T_{amb} = 70\text{ °C}$)	15	W
T_{op}	Operating temperature	0 to 70	°C
T_{stg}, T_j	Storage and junction temperature	-40 to 150	°C

2.2 Thermal data

Table 3. Thermal data

Symbol	Parameter	Value	Unit
$R_{th\ j-case}$	Thermal resistance junction-case	Typ = 1.8; Max = 2.5	°C/W
$R_{th\ j-amb}$	Thermal resistance junction-ambient	48	°C/W

3 Electrical characteristics

Unless otherwise stated, the values in the table below are given for conditions $V_{CC} = 9.5\text{ V}$, $R_L = 8\ \Omega$, $f = 1\text{ kHz}$, $T_{amb} = 25\text{ }^\circ\text{C}$.

Table 4. Electrical characteristics

Symbol	Parameter	Test condition	Min.	Typ.	Max	Unit
V_{CC}	Supply range		3	9.5	13	V
I_q	Total quiescent current			50	65	mA
V_{OS}	Output offset voltage				120	mV
P_O	Output power	THD 10%	4.5	5		W
THD	Total harmonic distortion	$P_O = 1\text{ W}$		0.05	0.2	%
		$P_O = 0.1\text{ W to }2\text{ W}$ $f = 100\text{ Hz to }15\text{ kHz}$			1	%
SVR	Supply voltage rejection	$f = 100\text{ Hz}$, $VR = 0.5\text{ V}$	40	56		dB
CT	Crosstalk		46	60		dB
A_{MUTE}	Mute attenuation		60	80		dB
T_W	Thermal threshold			150		$^\circ\text{C}$
G_V	Closed loop voltage gain		25	26	27	dB
ΔG_V	Voltage gain matching				0.5	dB
R_i	Input resistance		25	30		k Ω
$V_{T_{MUTE}}$	Mute threshold	for $V_{CC} > 6.4\text{ V}$; $V_O = -30\text{ dB}$	2.3	2.9	4.1	V
		for $V_{CC} < 6.4\text{ V}$; $V_O = -30\text{ dB}$	$V_{CC}/2 - 1$	$V_{CC}/2 - 0.75$	$V_{CC}/2 - 0.5$	V
$V_{T_{ST-BY}}$	St-by threshold		0.8	1.3	1.8	V
I_{ST-BY}	St-by current $V6 = \text{GND}$				100	μA
e_N	Total output voltage	A curve; $f = 20\text{ Hz to }20\text{ kHz}$		150		μV

4 Application suggestions

Standby and mute functions

4.1 Microprocessor application

In order to avoid annoying "pop noise" during turn-on/off transients, the correct sequence of the st-by and mute signals must be ensured which is quite simple when using a microprocessor (*Figure 3* and *4*).

First the st-by signal (from the microprocessor) goes high and the voltage across the st-by terminal (pin 7) starts to increase exponentially. The external RC network is intended to turn on slowly the biasing circuits of the amplifier, in order to avoid "pop" and "click" on the outputs.

When this voltage reaches the st-by threshold level, the amplifier is switched on, and the external capacitors in series to the input terminals (C3, C53) start to charge.

The mute signal must be held low until the capacitors are fully charged, in order to avoid that the device goes in play mode causing a loud "pop noise" on the speakers.

A delay of 100 - 200 ms between the st-by and mute signals is suitable for proper operation.

Figure 3. Microprocessor application

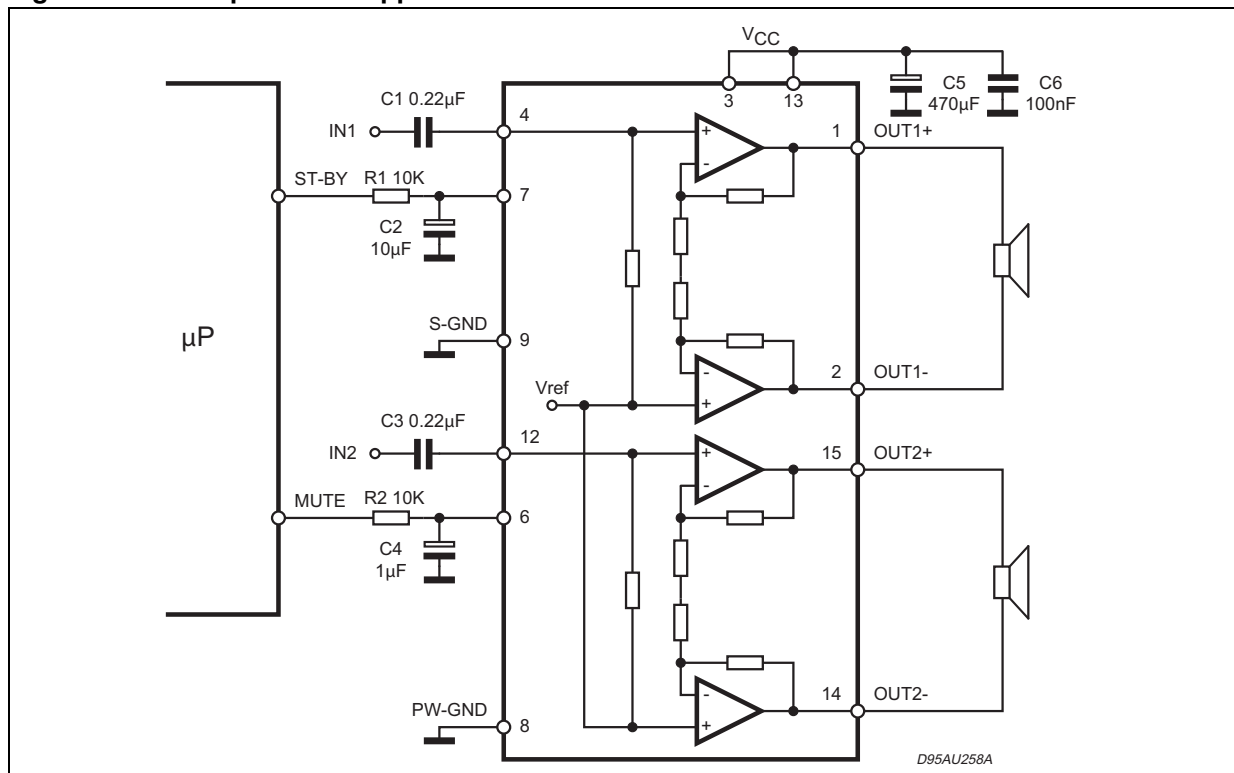
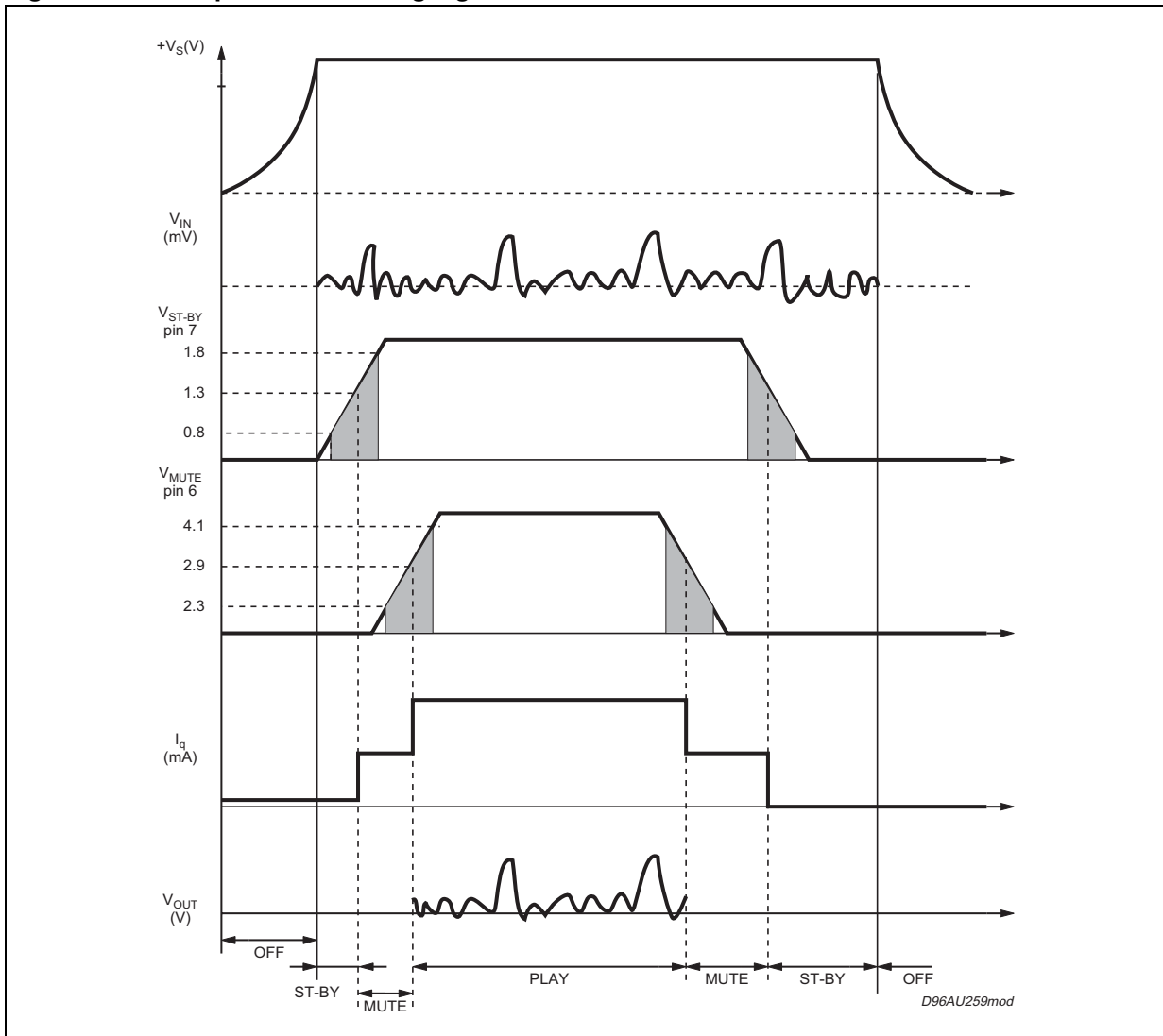

Figure 4. Microprocessor driving signals



4.2 Low-cost application

In low-cost applications where the microprocessor is not present, the recommended circuit is shown in *Figure 5*.

The st-by and mute terminals are tied together and they are connected to the supply line via an external voltage divider.

The device is switched on/off from the supply line and the external capacitor C4 is used to delay exceeding the st-by and mute threshold in order to avoid "popping" noise.

Figure 5. Standalone low-cost application

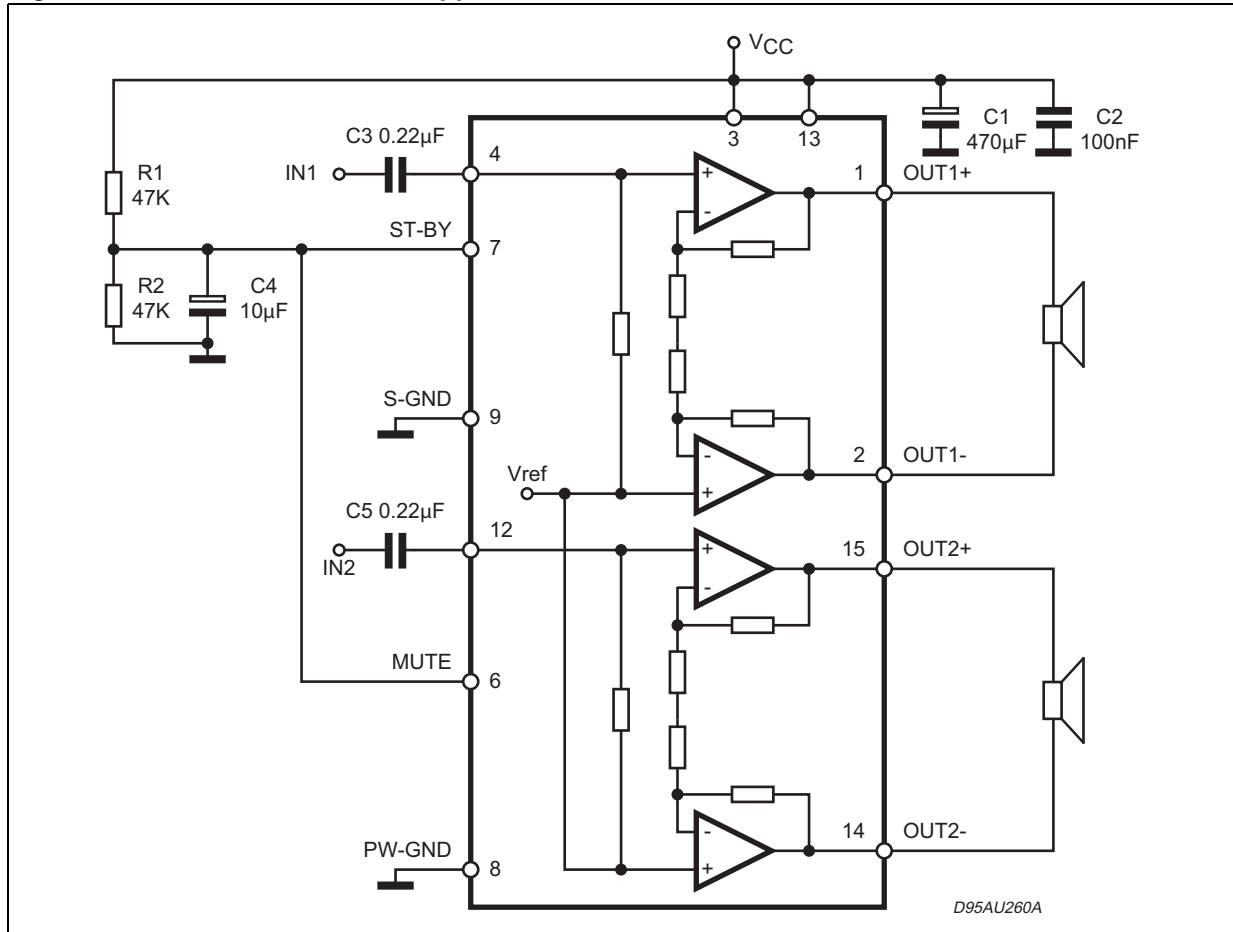

5 Characterization curves

Figure 6. Distortion vs. frequency

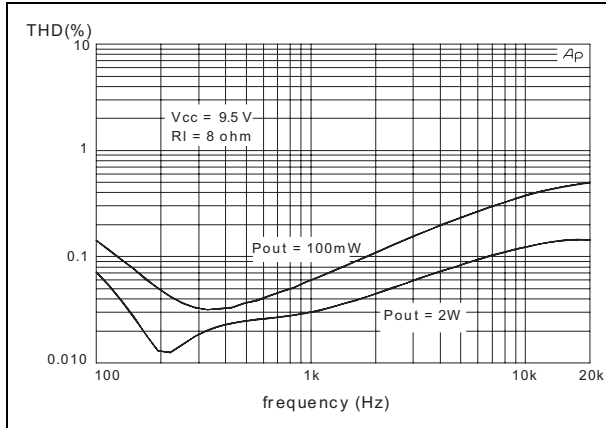

Figure 7. Gain vs. frequency

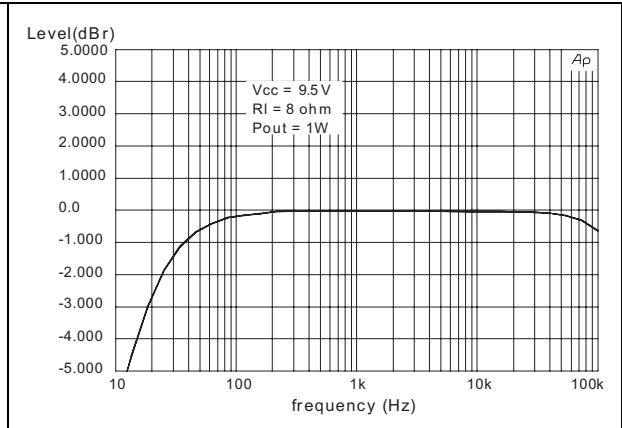

Figure 8. Mute attenuation vs. Vpin 6

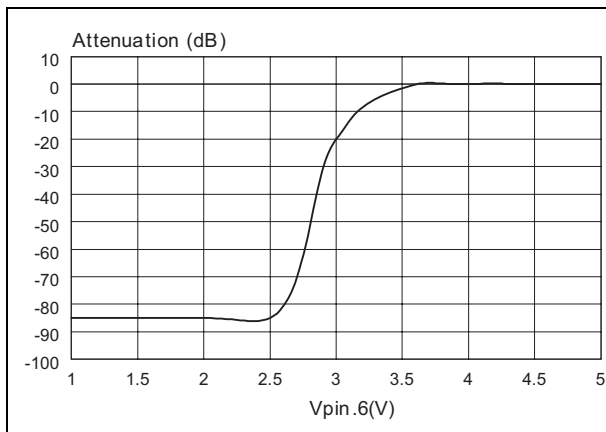

Figure 9. Quiescent current vs. supply voltage

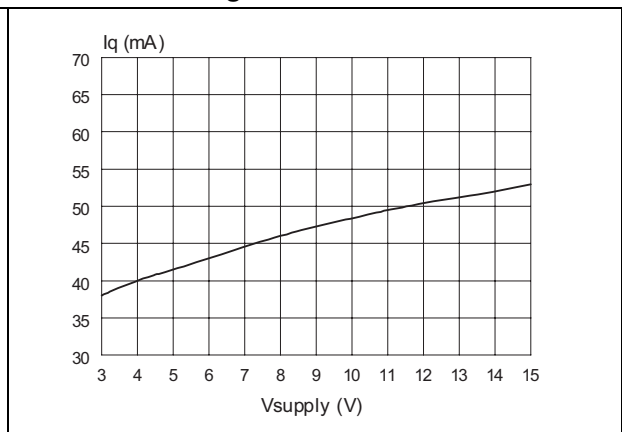
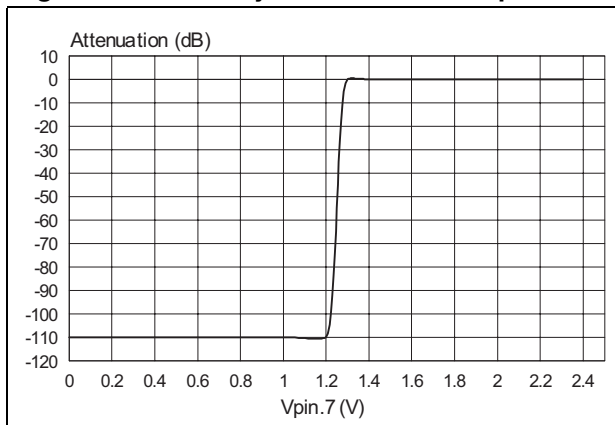

Figure 10. Standby attenuation vs. Vpin 7



6 PCB layout

Figure 11. Reference board component layout

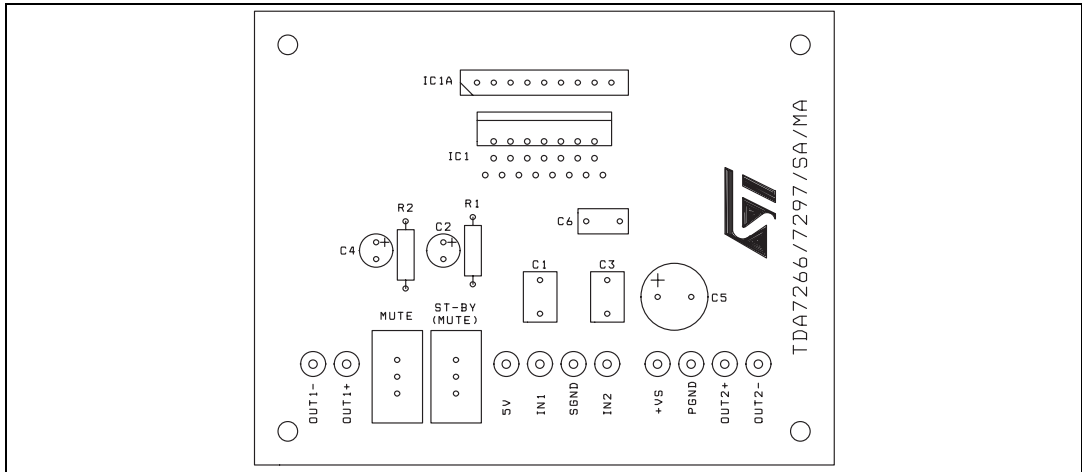

Figure 12. Reference board top layer layout

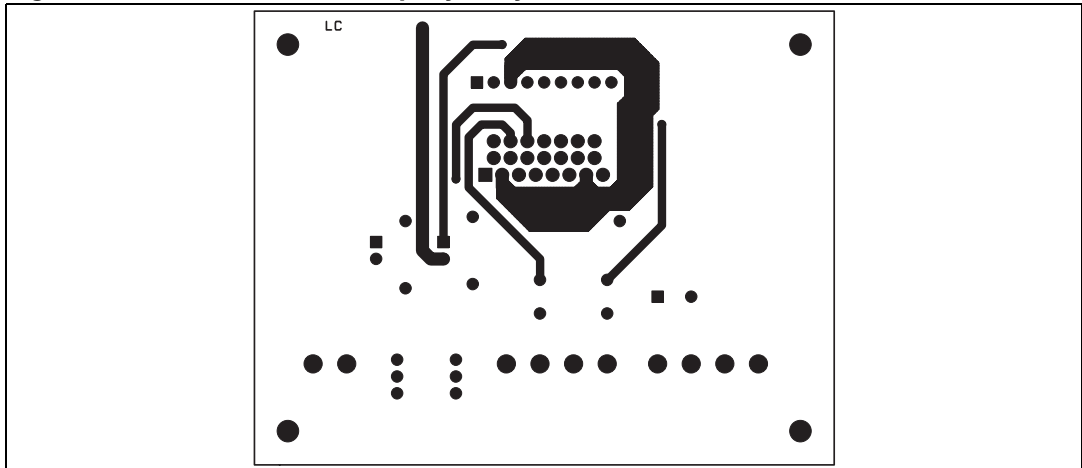
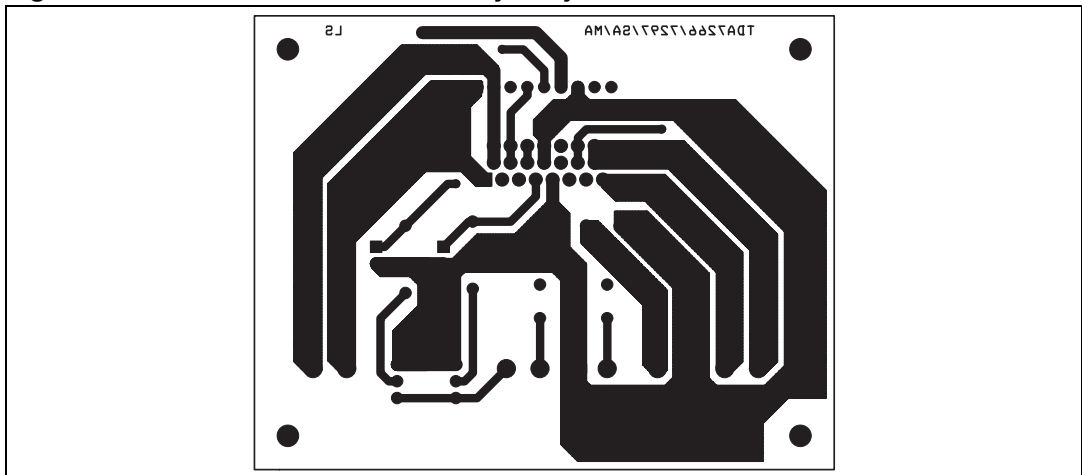

Figure 13. Reference board bottom layer layout



7 Heatsink dimensioning

In order to avoid triggering the thermal protection which is set approximatively at $T_j = 150^\circ\text{C}$, it is important to correctly dimension the heat sinker R_{Th} ($^\circ\text{C}/\text{W}$).

The parameters that influence the dimensioning are:

- Maximum dissipated power for the device (P_{dmax})
- Max. thermal resistance junction to case ($R_{Th\ j-c}$)
- Max. ambient temperature $T_{amb\ max}$
- Quiescent current I_q (mA)

Example:

$V_{CC} = 9.5\text{ V}$, $R_{load} = 8\text{ ohm}$, $R_{Th\ j-c} = 2.5\text{ }^\circ\text{C}/\text{W}$, $T_{amb\ max} = 50\text{ }^\circ\text{C}$

$$P_{dmax} = (N^\circ\text{channels}) \cdot \frac{V_{CC}^2}{\Pi^2 \cdot \frac{R_{load}}{2}} + I_q \cdot V_{CC}$$

$$P_{dmax} = 2 \cdot (2.3) + 0.47 = 5.07\text{ W}$$

$$(\text{HeatSink})R_{Th\ c-a} = \frac{150 - T_{amb\ max}}{P_{dmax}} - R_{Th\ j-c} = \left(\frac{150 - 50}{5.07} - 2.5\right) = 17.2^\circ\text{C}/\text{W}$$

Figure 14 shows the power derating curve for the device.

Figure 14. Power derating curve

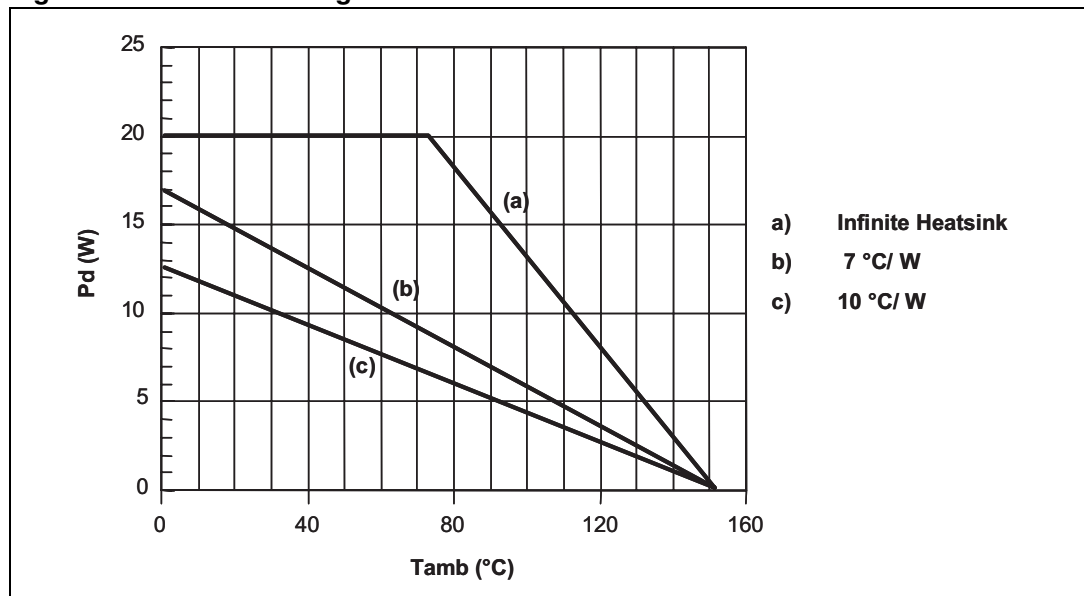

8 Package mechanical data

In order to meet environmental requirements, ST offers these devices in different grades of ECOPACK® packages, depending on their level of environmental compliance. ECOPACK® specifications, grade definitions and product status are available at: www.st.com. ECOPACK® is an ST trademark.

Clipwatt assembly suggestions

The recommended mounting method of the Clipwatt on an external heatsink requires the use of a clip placed as close as possible to the center of the plastic body, as indicated in the example of [Figure 15](#).

A thermal grease can be used in order to reduce the additional thermal resistance of the contact between the package and heatsink.

A force of 7 - 10 kg gives a good contact and the clip must be designed in order to withstand a maximum contact pressure of 15 kg/mm² between itself and the plastic body case.

For example, if a 15 kg force is applied by the clip on the package, the clip must have a contact area of at least 1 mm².

Figure 15. Example of right placement of the clip

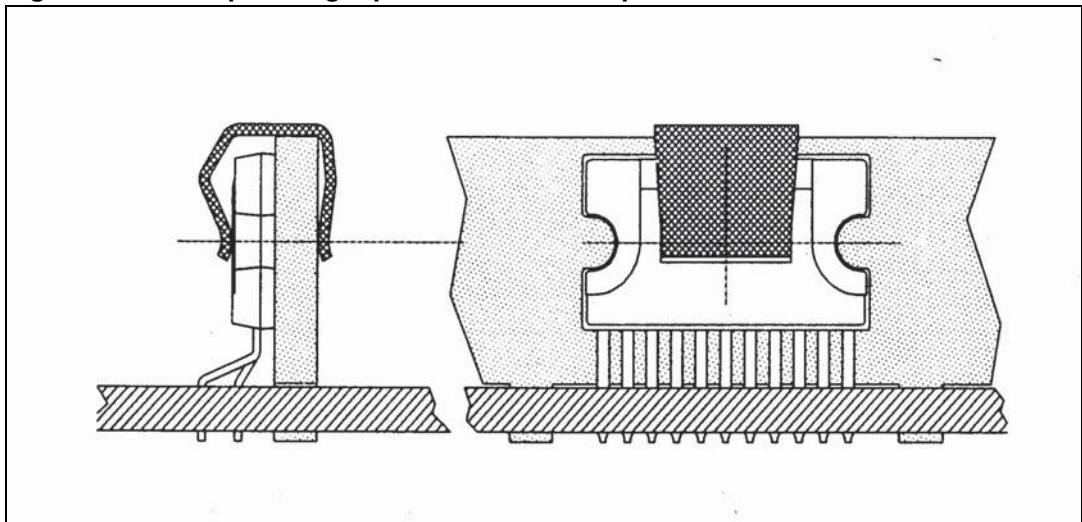
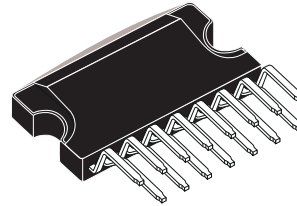

Figure 16. Clipwatt15 package outline and mechanical data

DIM.	mm			inch		
	MIN.	TYP.	MAX.	MIN.	TYP.	MAX.
A			3.2			0.126
B			1.05			0.041
C		0.15			0.006	
D		1.55			0.061	
E	0.49		0.55	0.019		0.022
F	0.67		0.73	0.026		0.029
G	1.14	1.27	1.4	0.045	0.050	0.055
G1	17.57	17.78	17.91	0.692	0.700	0.705
H1		12			0.480	
H2		18.6			0.732	
H3	19.85			0.781		
L		17.95			0.707	
L1		14.45			0.569	
L2	10.7	11	11.2	0.421	0.433	0.441
L3		5.5			0.217	
M		2.54			0.100	
M1		2.54			0.100	

OUTLINE AND MECHANICAL DATA

Weight: 1.92gr



Clipwatt15

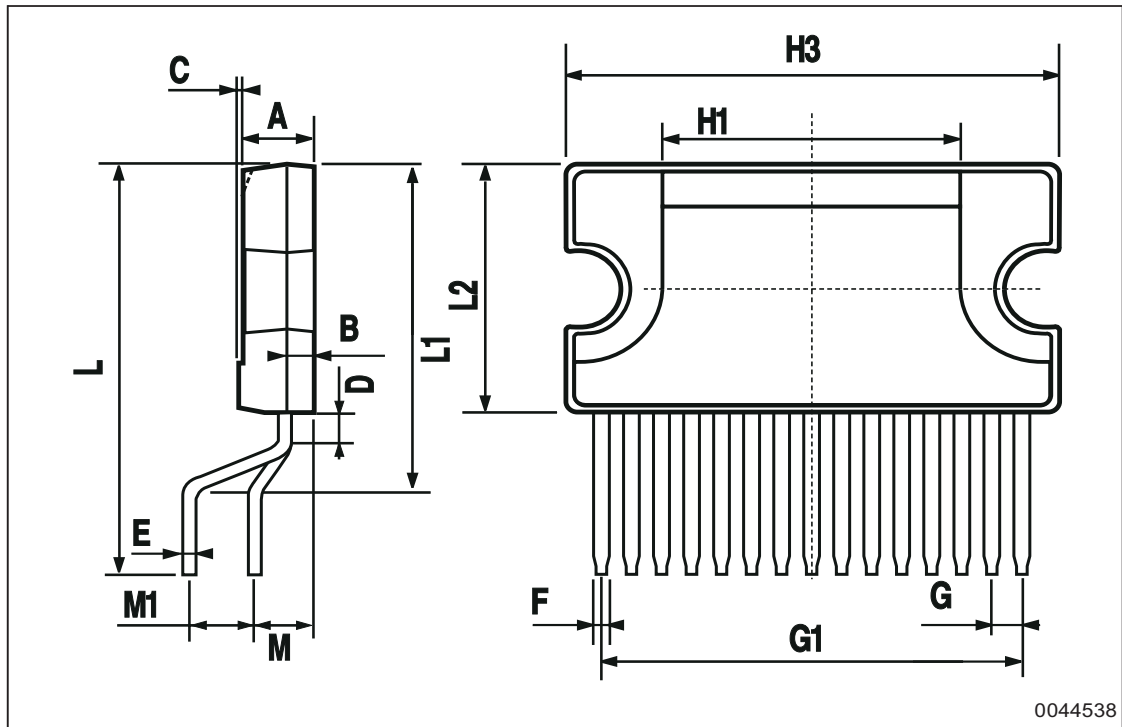

0044538

9 Revision history

Table 5. Document revision history

Date	Revision	Changes
31-Aug-2012	1	Initial release.

Please Read Carefully:

Information in this document is provided solely in connection with ST products. STMicroelectronics NV and its subsidiaries ("ST") reserve the right to make changes, corrections, modifications or improvements, to this document, and the products and services described herein at any time, without notice.

All ST products are sold pursuant to ST's terms and conditions of sale.

Purchasers are solely responsible for the choice, selection and use of the ST products and services described herein, and ST assumes no liability whatsoever relating to the choice, selection or use of the ST products and services described herein.

No license, express or implied, by estoppel or otherwise, to any intellectual property rights is granted under this document. If any part of this document refers to any third party products or services it shall not be deemed a license grant by ST for the use of such third party products or services, or any intellectual property contained therein or considered as a warranty covering the use in any manner whatsoever of such third party products or services or any intellectual property contained therein.

UNLESS OTHERWISE SET FORTH IN ST'S TERMS AND CONDITIONS OF SALE ST DISCLAIMS ANY EXPRESS OR IMPLIED WARRANTY WITH RESPECT TO THE USE AND/OR SALE OF ST PRODUCTS INCLUDING WITHOUT LIMITATION IMPLIED WARRANTIES OF MERCHANTABILITY, FITNESS FOR A PARTICULAR PURPOSE (AND THEIR EQUIVALENTS UNDER THE LAWS OF ANY JURISDICTION), OR INFRINGEMENT OF ANY PATENT, COPYRIGHT OR OTHER INTELLECTUAL PROPERTY RIGHT.

UNLESS EXPRESSLY APPROVED IN WRITING BY TWO AUTHORIZED ST REPRESENTATIVES, ST PRODUCTS ARE NOT RECOMMENDED, AUTHORIZED OR WARRANTED FOR USE IN MILITARY, AIR CRAFT, SPACE, LIFE SAVING, OR LIFE SUSTAINING APPLICATIONS, NOR IN PRODUCTS OR SYSTEMS WHERE FAILURE OR MALFUNCTION MAY RESULT IN PERSONAL INJURY, DEATH, OR SEVERE PROPERTY OR ENVIRONMENTAL DAMAGE. ST PRODUCTS WHICH ARE NOT SPECIFIED AS "AUTOMOTIVE GRADE" MAY ONLY BE USED IN AUTOMOTIVE APPLICATIONS AT USER'S OWN RISK.

Resale of ST products with provisions different from the statements and/or technical features set forth in this document shall immediately void any warranty granted by ST for the ST product or service described herein and shall not create or extend in any manner whatsoever, any liability of ST.

ST and the ST logo are trademarks or registered trademarks of ST in various countries.

Information in this document supersedes and replaces all information previously supplied.

The ST logo is a registered trademark of STMicroelectronics. All other names are the property of their respective owners.

© 2012 STMicroelectronics - All rights reserved

STMicroelectronics group of companies

Australia - Belgium - Brazil - Canada - China - Czech Republic - Finland - France - Germany - Hong Kong - India - Israel - Italy - Japan - Malaysia - Malta - Morocco - Philippines - Singapore - Spain - Sweden - Switzerland - United Kingdom - United States of America

www.st.com

