

IS31AP2036

HIGH EFFICIENCY, CLASS-K AUDIO POWER AMPLIFIER WITH INTEGRATED CHARGE PUMP CONVERTER

Advanced Information

January 2014

GENERAL DESCRIPTION

The IS31AP2036 is a Class-K audio power amplifier with high efficiency and automatic gain control. It drives up to 2.0W (10% THD+N) into an 8Ω speaker from a 4.2V V_{CC} supply.

The IS31AP2036 integrates advanced K-charge pump which increases efficiency up to 92% and whole power amplifier efficiency to 75%. The output power will be maintained in 0.8W, 1.0W and 1.2W.

The IS31AP2036 provides low cost, space saving solution for portable equipments which need audio output with higher power by boosting up supply voltage. Its external components just include a few capacitors and resistors (no inductor).

The IS31AP2036 use fully differential design to reduce RF noise. The IS31AP2036 integrates de-pop circuitry to reduce pop and click noise during power on/off or shutdown enable operation. The IS31AP2036 also integrates thermal and short circuit protection function.

IS31AP2036 is available in FC-16 (2mm × 2mm) package. It operates from 3.0V to 5.0V over the temperature range of -40°C to +85°C.

FEATURES

- Operates from 3.0V to 5.0V
- Advanced K-charge pump technology, efficiency up to 92%
- Low EMI
- -65dB (217Hz) high PSRR
- 0.2% low THD+N
- New AGC function
- Pulse Count Control serial interface
- Output power in 0.8W, 1W and 1.2W levels
- Thermal and short-circuit protection
- Integrated Click-and-Pop suppression circuitry
- Available in FC-16 (2mm × 2mm) package

APPLICATIONS

- Smart phones
- Cellular phones
- PDAs
- GPS
- Portable electronics

TYPICAL APPLICATION CIRCUIT

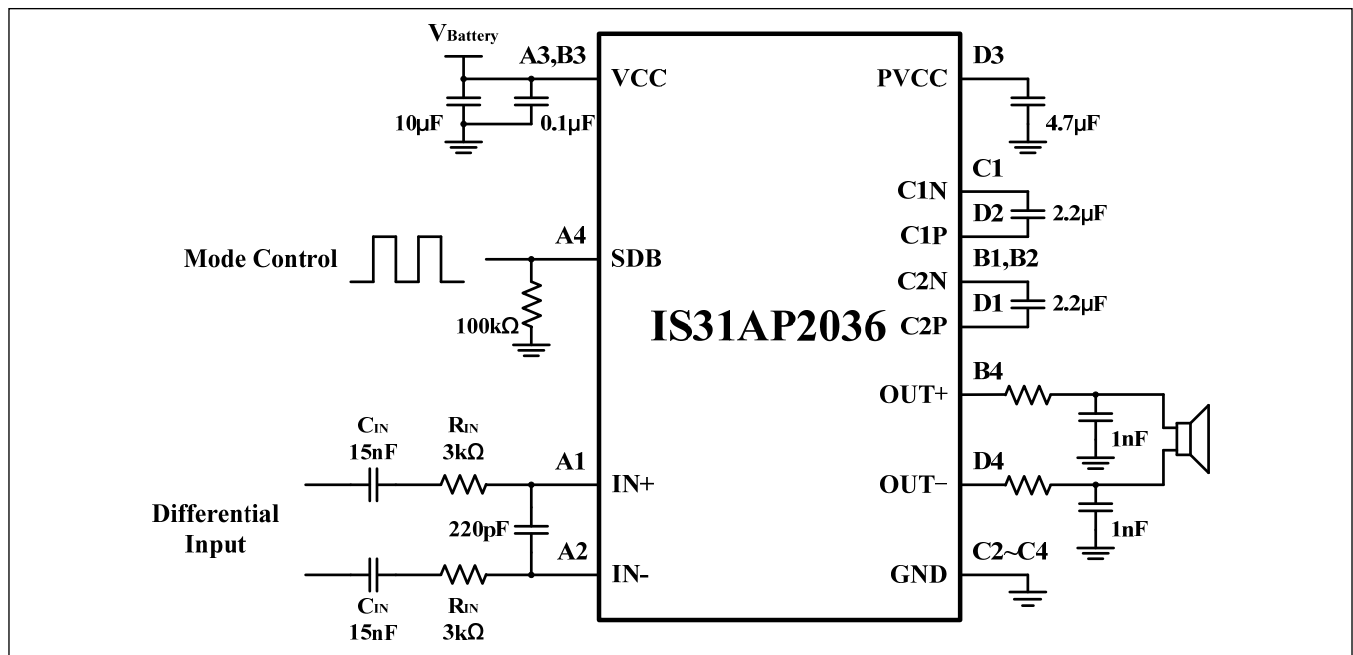

Figure 1 Typical Application Circuit (Differential Input)

IS31AP2036

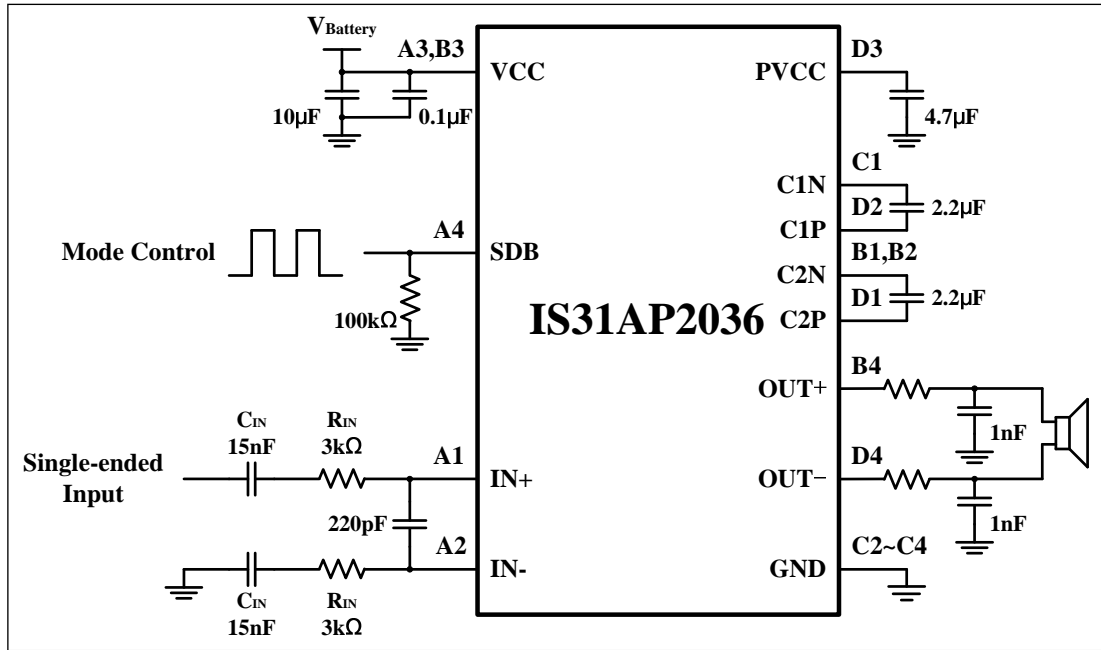

Figure 2 Typical Application Circuit (Single-ended Input)

IS31AP2036

PIN CONFIGURATION

Package	Pin Configuration (Top View)																																
FC-16	<table border="1" style="margin-left: auto; margin-right: auto;"> <tr> <td>• IN+</td> <td>IN-</td> <td>VCC</td> <td>SDB</td> </tr> <tr> <td>(A1)</td> <td>(A2)</td> <td>(A3)</td> <td>(A4)</td> </tr> <tr> <td>C2N</td> <td>C2N</td> <td>VCC</td> <td>OUT+</td> </tr> <tr> <td>(B1)</td> <td>(B2)</td> <td>(B3)</td> <td>(B4)</td> </tr> <tr> <td>C1N</td> <td>GND</td> <td>GND</td> <td>GND</td> </tr> <tr> <td>(C1)</td> <td>(C2)</td> <td>(C3)</td> <td>(C4)</td> </tr> <tr> <td>C2P</td> <td>C1P</td> <td>PVCC</td> <td>OUT-</td> </tr> <tr> <td>(D1)</td> <td>(D2)</td> <td>(D3)</td> <td>(D4)</td> </tr> </table>	• IN+	IN-	VCC	SDB	(A1)	(A2)	(A3)	(A4)	C2N	C2N	VCC	OUT+	(B1)	(B2)	(B3)	(B4)	C1N	GND	GND	GND	(C1)	(C2)	(C3)	(C4)	C2P	C1P	PVCC	OUT-	(D1)	(D2)	(D3)	(D4)
• IN+	IN-	VCC	SDB																														
(A1)	(A2)	(A3)	(A4)																														
C2N	C2N	VCC	OUT+																														
(B1)	(B2)	(B3)	(B4)																														
C1N	GND	GND	GND																														
(C1)	(C2)	(C3)	(C4)																														
C2P	C1P	PVCC	OUT-																														
(D1)	(D2)	(D3)	(D4)																														

PIN DESCRIPTION

No.	Pin	Description
A1	IN+	Positive audio input.
A2	IN-	Negative audio input.
A3, B3	VCC	Power supply.
A4	SDB	Shutdown pin. Active low.
B1, B2	C2N	Negative input for external flying cap 2.
B4	OUT+	Positive audio output.
C1	C1N	Negative input for external flying cap 1.
C2~C4	GND	Amplifier supply voltage.
D1	C2P	Positive input for external flying cap 2.
D2	C1P	Positive input for external flying cap 1.
D3	PVCC	Charge pump output voltage.
D4	OUT-	Negative audio output.



IS31AP2036

ORDERING INFORMATION (TBD)
INDUSTRIAL RANGE: -40°C TO +85°C

Order Part No.	Package	QTY/Reel
IS31AP2036-xxLS2-TR	FC-16, Lead-free	2500

Copyright © 2013 Integrated Silicon Solution, Inc. All rights reserved. ISSI reserves the right to make changes to this specification and its products at any time without notice. ISSI assumes no liability arising out of the application or use of any information, products or services described herein. Customers are advised to obtain the latest version of this device specification before relying on any published information and before placing orders for products. Integrated Silicon Solution, Inc. does not recommend the use of any of its products in life support applications where the failure or malfunction of the product can reasonably be expected to cause failure of the life support system or to significantly affect its safety or effectiveness. Products are not authorized for use in such applications unless Integrated Silicon Solution, Inc. receives written assurance to its satisfaction, that:

- a.) the risk of injury or damage has been minimized;
- b.) the user assume all such risks; and
- c.) potential liability of Integrated Silicon Solution, Inc is adequately protected under the circumstances

IS31AP2036

ABSOLUTE MAXIMUM RATINGS

Supply voltage, V_{CC}	-0.3V ~ +6.0V
Voltage at IN+ and IN- pins	-0.3V ~ $V_{CC}+0.3V$
Maximum junction temperature, T_{JMAX}	125°C
Storage temperature range, T_{STG}	-65°C ~ +150°C
Operating temperature range, T_A	-40°C ~ +85°C
Thermal resistance, junction to ambient, $R_{\theta JA}$	69°C/W
ESD (HBM)	TBD
ESD (CDM)	TBD

Note:

Stresses beyond those listed under "Absolute Maximum Ratings" may cause permanent damage to the device. These are stress ratings only and functional operation of the device at these or any other condition beyond those indicated in the operational sections of the specifications is not implied. Exposure to absolute maximum rating conditions for extended periods may affect device reliability.

DC CHARACTERISTICS (TBD)

$T_A = 25^\circ\text{C}$, $V_{CC} = 3.0V \sim 5.0V$, unless otherwise noted. Typical value are $T_A = 25^\circ\text{C}$, $V_{CC} = 3.6V$.

Symbol	Parameter	Condition	Min.	Typ.	Max.	Unit
V_{CC}	Supply voltage		3.0		5.0	V
I_{CC}	Quiescent current	$V_{CC} = 3.6V$, no load, no input		9.5		mA
I_{SD}	Shutdown current	$V_{CC} = 3.6V$, $V_{SDB} = 0V$			1	μA
f_{OSC}	Clock frequency	$V_{CC} = 2.5V \sim 4.5V$	600	800	1000	kHz
A_V	Output gain	$R_{IN} = 3k\Omega$		16.3		V/V
t_{ON}	Turn on time			40		ms
$ V_{OS} $	Output offset voltage	$V_{CC} = 2.5V \sim 4.5V$, no input	-30	0	30	mV
R_{INT}	Internal input resistor			16.5		k Ω
V_{IH}	Input logic high voltage		1.3		V_{CC}	V
V_{IL}	Input logic low voltage		0		0.35	V
T_{AGC}	Thermal AGC threshold temperature			150		$^\circ\text{C}$
T_{AGC_HYS}	Thermal AGC hysteresis temperature			20		$^\circ\text{C}$
T_{OTP}	Over temperature protection	(Note 1)		160		$^\circ\text{C}$
T_{TOP_HYS}	Hysteresis temperature	(Note 1)		30		$^\circ\text{C}$

K-Charge Pump

PV_{CC}	Charge pump output voltage	$V_{CC} = 3.0V \sim 3.8V$		$1.5V_{CC}$		V
		$V_{CC} > 3.8V$		5.8		V
V_{HYS}	OVP hysteresis voltage	$V_{CC} > 3.8V$		50		mV
η	Efficiency	$V_{CC} = 4.2V$		92		%
t_{ST}	Soft start time	$C_{OUT} = 4.7\mu\text{F}$, no load	1.0	1.2	1.4	ms
I_L	PV_{CC} short to GND limit current			350		mA

IS31AP2036

AC CHARACTERISTICS (Note 1)

$T_A = 25^\circ\text{C}$, $V_{CC} = 3.6\text{V}$, unless otherwise noted.

Symbol	Parameter	Condition	Min.	Typ.	Max.	Unit
P _O	Output power, Mode 4	THD+N = 10%, f = 1kHz R _L = 8Ω+33μH	V _{CC} = 3.6V	1.5		W
			V _{CC} = 4.2V	2.0		
		THD+N = 1%, f = 1kHz R _L = 8Ω+33μH	V _{CC} = 3.6V	1.23		
			V _{CC} = 4.2V	1.65		
P _{NCN}	NCN output power	V _{CC} = 4.2V, R _L = 8Ω+33μH, THD+N = 0.25%	Mode 1	1.2		W
			Mode 2	1.0		
			Mode 3	0.8		
THD+N	Total harmonic distortion plus noise	V _{CC} = 4.2V, P _O = 1W, R _L = 8Ω+33μH f = 1kHz, Mode 1		0.2		%
		V _{CC} = 4.2V, P _O = 1.2W, R _L = 8Ω+33μH f = 1kHz, Mode 4		0.2		
t _{WU}	Wake-up time from shutdown			40		ms
η	Efficiency	V _{CC} = 4.2V, P _O = 1.2W, R _L = 8Ω		75		%
PSRR	Power supply rejection ratio	V _{CC} = 4.2V, V _{P-P} = 200mV, R _L = 8Ω, f = 217Hz	-53	-65		dB
		V _{CC} = 4.2V, V _{P-P} = 200mV, R _L = 8Ω, f = 1kHz	-53	-65		
NCN						
t _{AT}	Attack time			40		ms
t _{RL}	Release time			1.2		s
A _{max}	Max attenuation gain			-13.5		dB
Pulse Count Control						
t _L	Mode control low time	V _{CC} = 2.5V~4.5V	0.75	2	10	μs
t _H	Mode control high time	V _{CC} = 2.5V~4.5V	0.75	2	10	μs
t _{LAT}	Mode latch up time	V _{CC} = 2.5V~4.5V	150		500	μs
t _{OFF}	Shutdown time	V _{CC} = 2.5V~4.5V	150		500	μs

Note 1: Guaranteed by design.

IS31AP2036

CLASSIFICATION REFLOW PROFILES

Profile Feature	Pb-Free Assembly
Preheat & Soak Temperature min (T _{smn}) Temperature max (T _{smax}) Time (T _{smn} to T _{smax}) (t _s)	150°C 200°C 60-120 seconds
Average ramp-up rate (T _{smax} to T _p)	3°C/second max.
Liquidous temperature (T _L) Time at liquidous (t _L)	217°C 60-150 seconds
Peak package body temperature (T _p)*	Max 260°C
Time (t _p)** within 5°C of the specified classification temperature (T _c)	Max 30 seconds
Average ramp-down rate (T _p to T _{smax})	6°C/second max.
Time 25°C to peak temperature	8 minutes max.

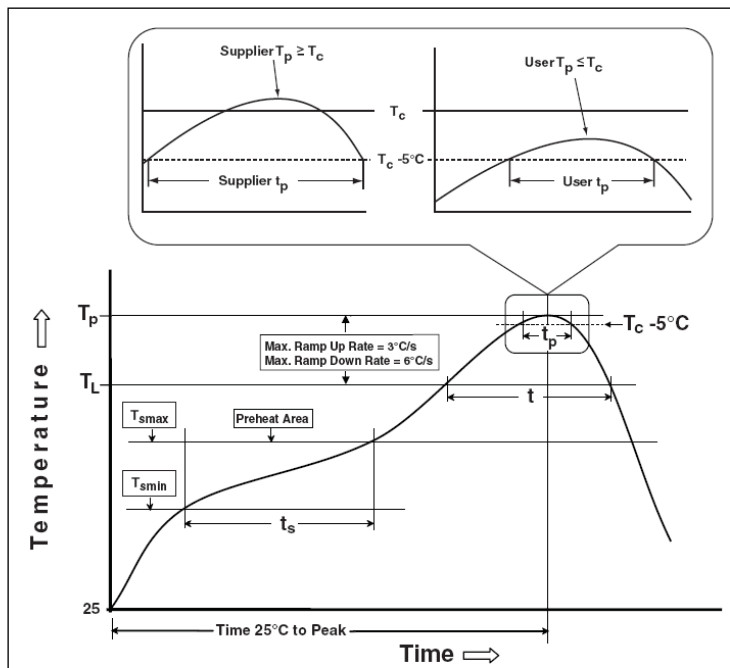
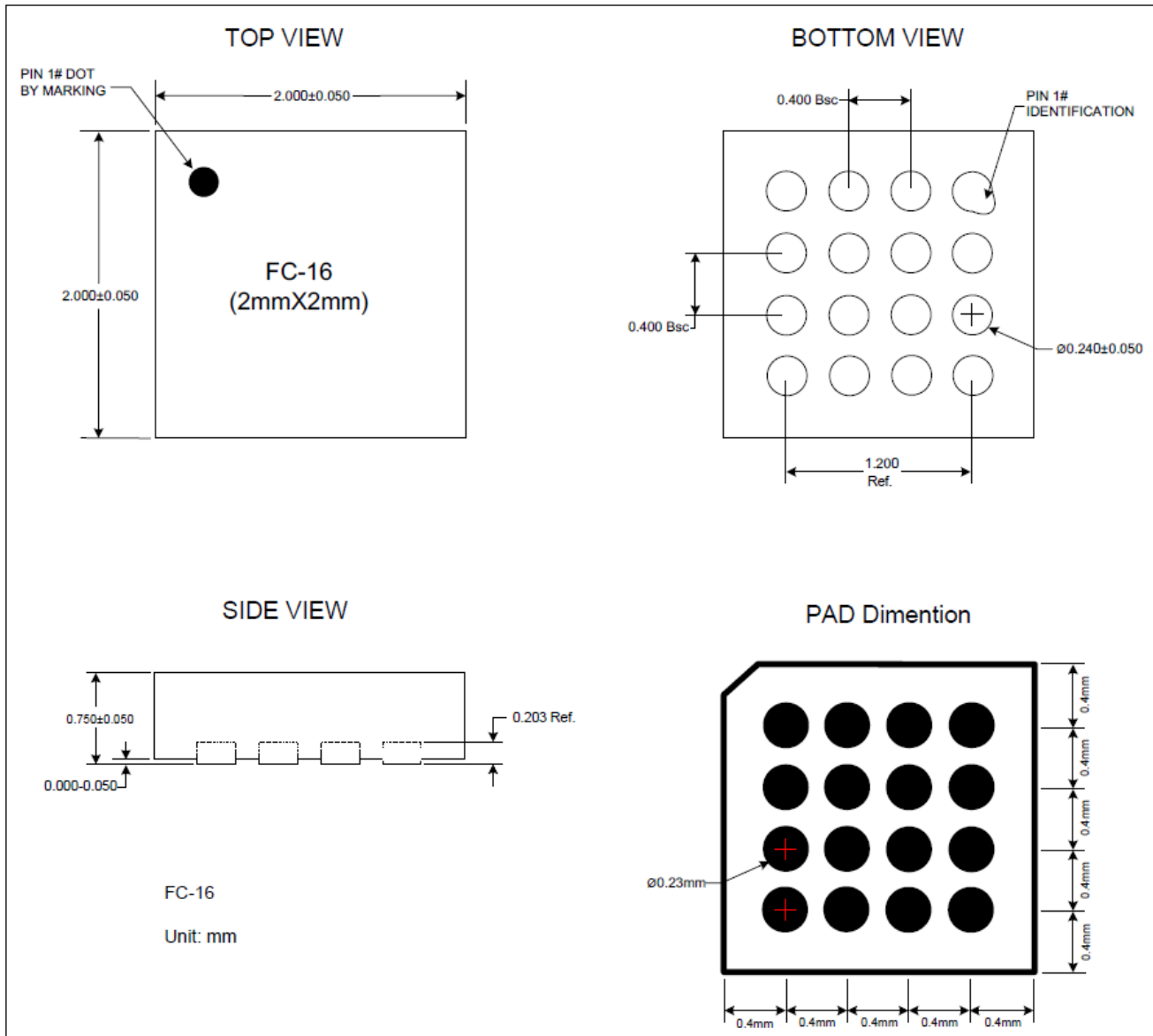

Figure 13 Classification Profile

IS31AP2036

PACKAGE INFORMATION

FC-16 (TBD)



Note: All dimensions in millimeters unless otherwise stated.