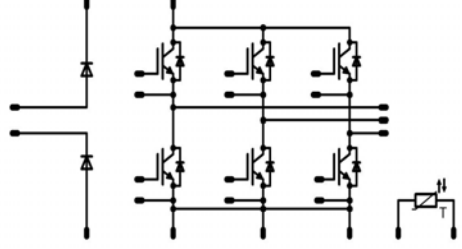

flowPACK 1	1200V/15A
<div style="border: 1px solid black; padding: 5px; margin-bottom: 5px;"> <p style="text-align: center; background-color: #000080; color: white; margin: 0;">Features</p> <ul style="list-style-type: none"> Inverter, blocking diodes Very compact housing, easy to route IGBT4 technology </div> <div style="border: 1px solid black; padding: 5px; margin-bottom: 5px;"> <p style="text-align: center; background-color: #000080; color: white; margin: 0;">Target Applications</p> <ul style="list-style-type: none"> Power Regeneration </div> <div style="border: 1px solid black; padding: 5px;"> <p style="text-align: center; background-color: #000080; color: white; margin: 0;">Types</p> <ul style="list-style-type: none"> 10-F112R6A015SC-M438E08 10-F112R6A015SC01-M438E18 </div>	<div style="border: 1px solid black; padding: 5px; margin-bottom: 5px;"> <p style="text-align: center; background-color: #000080; color: white; margin: 0;">flow1 housing</p>  </div> <div style="border: 1px solid black; padding: 5px;"> <p style="text-align: center; background-color: #000080; color: white; margin: 0;">Schematic</p>  </div>

Maximum Ratings

$T_j=25^{\circ}\text{C}$, unless otherwise specified

Parameter	Symbol	Condition	Value	Unit
Blocking Diode				
Repetitive peak reverse voltage	V_{RRM}		1600	V
DC forward current	I_{FAV}	$T_j=T_{jmax}$ $T_h=80^{\circ}\text{C}$	36	A
Surge forward current	I_{FSM}	$t_p=10\text{ms}$ $T_j=25^{\circ}\text{C}$	370	A
I2t-value	I^2t		360	A^2s
Power dissipation per Diode	P_{tot}	$T_j=T_{jmax}$ $T_h=80^{\circ}\text{C}$	42	W
Maximum Junction Temperature	T_{jmax}		150	$^{\circ}\text{C}$
Inverter Transistor				
Collector-emitter break down voltage	V_{CE}		1200	V
DC collector current	I_C	$T_j=T_{jmax}$ $T_h=80^{\circ}\text{C}$	20	A
Repetitive peak collector current	I_{Cpulse}	t_p limited by T_{jmax}	45	A
Turn off safe operating area		$V_{CE} \leq 1200\text{V}$, $T_j \leq T_{op max}$	30	A
Power dissipation per IGBT	P_{tot}	$T_j=T_{jmax}$ $T_h=80^{\circ}\text{C}$	57	W
Gate-emitter peak voltage	V_{GE}		± 20	V
Short circuit ratings	t_{SC} V_{CC}	$T_j \leq 150^{\circ}\text{C}$ $V_{GE}=15\text{V}$	10 800	μs V
Maximum Junction Temperature	T_{jmax}		175	$^{\circ}\text{C}$

Maximum Ratings

 $T_j=25^{\circ}\text{C}$, unless otherwise specified

Parameter	Symbol	Condition	Value	Unit
-----------	--------	-----------	-------	------

Inverter Diode

Peak Repetitive Reverse Voltage	V_{RRM}	$T_j=25^{\circ}\text{C}$	1200	V
DC forward current	I_F	$T_j=T_{jmax}$ $T_h=80^{\circ}\text{C}$	18	A
Repetitive peak forward current	I_{FRM}	t_p limited by T_{jmax}	30	A
Power dissipation per Diode	P_{tot}	$T_j=T_{jmax}$ $T_h=80^{\circ}\text{C}$	38	W
Maximum Junction Temperature	T_{jmax}		175	$^{\circ}\text{C}$

Thermal Properties

Storage temperature	T_{stg}		-40...+125	$^{\circ}\text{C}$
Operation temperature under switching condition	T_{op}		-40...+($T_{jmax} - 25$)	$^{\circ}\text{C}$

Insulation Properties

Insulation voltage	V_{is}	$t=2\text{s}$ DC voltage	4000	V
Creepage distance			min 12.7	mm
Clearance			min 12.7	mm
Comparative tracking index	CTI		>200	

Characteristic Values

Parameter	Symbol	Conditions					Value			Unit
		$V_{GE}[V]$ or $V_{GS}[V]$	$V_r[V]$ or $V_{CE}[V]$ or $V_{DS}[V]$	$I_c[A]$ or $I_F[A]$ or $I_D[A]$	T_j	Min	Typ	Max		
Blocking Diode										
Forward voltage	V_F				35	$T_j=25^\circ C$ $T_j=125^\circ C$	0.8	1.1 1.03	1.35	V
Threshold voltage (for power loss calc. only)	V_{td}				35	$T_j=25^\circ C$ $T_j=125^\circ C$		0.9 0.77		V
Slope resistance (for power loss calc. only)	r_t				35	$T_j=25^\circ C$ $T_j=125^\circ C$		10 10		m Ω
Reverse current	I_r			1600		$T_j=25^\circ C$ $T_j=125^\circ C$			0.1	mA
Thermal resistance chip to heatsink per chip	R_{thJH}	Thermal grease thickness \leq 50um $\lambda = 1$ W/mK						1.68		K/W
Thermal resistance chip to heatsink per chip	R_{thJC}							td.		K/W
Inverter Transistor										
Gate emitter threshold voltage	$V_{GE(th)}$	$V_{CE}=V_{GE}$			0.0005	$T_j=25^\circ C$ $T_j=150^\circ C$	5	5.8	6.5	V
Collector-emitter saturation voltage	$V_{CE(sat)}$		15		15	$T_j=25^\circ C$ $T_j=150^\circ C$	1.6	1.84 2.25	2.25	V
Collector-emitter cut-off current incl. Diode	I_{CES}		0	1200		$T_j=25^\circ C$ $T_j=150^\circ C$			0.005	mA
Gate-emitter leakage current	I_{GES}		20	0		$T_j=25^\circ C$ $T_j=150^\circ C$			200	nA
Integrated Gate resistor	R_{gint}							none		Ω
Turn-on delay time	$t_{d(on)}$	Rgoff=8 Ω Rgon=8 Ω	± 15	600	15	$T_j=25^\circ C$ $T_j=150^\circ C$		85.2 84.8		ns
Rise time	t_r					$T_j=25^\circ C$ $T_j=150^\circ C$		17 21.8		
Turn-off delay time	$t_{d(off)}$					$T_j=25^\circ C$ $T_j=150^\circ C$		201 264		
Fall time	t_f					$T_j=25^\circ C$ $T_j=150^\circ C$		82.1 123		
Turn-on energy loss per pulse	E_{on}					$T_j=25^\circ C$ $T_j=150^\circ C$		0.82 1.26	mWs	
Turn-off energy loss per pulse	E_{off}					$T_j=25^\circ C$ $T_j=150^\circ C$		0.88 1.36		
Input capacitance	C_{ies}	f=1MHz	0	25		$T_j=25^\circ C$		900		pF
Output capacitance	C_{oss}							80		
Reverse transfer capacitance	C_{riss}							55		
Gate charge	Q_{Gate}		± 15			$T_j=25^\circ C$		120		nC
Thermal resistance chip to heatsink per chip	R_{thJH}	Thermal grease thickness \leq 50um $\lambda = 1$ W/mK						1.67		K/W
Thermal resistance chip to case per chip	R_{thJC}							td.		K/W
Inverter Diode										
Diode forward voltage	V_F				15	$T_j=25^\circ C$ $T_j=150^\circ C$	1.35	1.90 1.91	2.35	V
Peak reverse recovery current	I_{RRM}	Rgon=8 Ω	± 15	600	15	$T_j=25^\circ C$ $T_j=150^\circ C$			16.06	A
Reverse recovery time	t_{rr}					$T_j=25^\circ C$ $T_j=150^\circ C$		433.4		
Reverse recovered charge	Q_{rr}					$T_j=25^\circ C$ $T_j=150^\circ C$		2.75	μC	
Peak rate of fall of recovery current	$di(rec)max/dt$					$T_j=25^\circ C$ $T_j=150^\circ C$		109		
Reverse recovered energy	E_{rec}					$T_j=25^\circ C$ $T_j=150^\circ C$		1.16	mWs	
Thermal resistance chip to heatsink per chip	R_{thJH}					Thermal grease thickness \leq 50um $\lambda = 1$ W/mK				
Thermal resistance chip to case per chip	R_{thJC}							td.		K/W

Characteristic Values

Parameter	Symbol	Conditions					Value			Unit
		$V_{GE}[V]$ or $V_{GS}[V]$	$V_r[V]$ or $V_{CE}[V]$ or $V_{DS}[V]$	$I_c[A]$ or $I_F[A]$ or $I_D[A]$	T_j	Min	Typ	Max		
Thermistor										
Rated resistance	R					$T_j=25^\circ\text{C}$		22000		Ω
Deviation of R100	$\Delta R/R$	R100=1486 Ω				$T_c=100^\circ\text{C}$	-5		5	%
Power dissipation	P					$T_c=100^\circ\text{C}$		200		mW
Power dissipation constant						$T_j=25^\circ\text{C}$		2		mW/K
B-value	$B_{(25/50)}$	Tol. $\pm 3\%$				$T_j=25^\circ\text{C}$		3950		K
B-value	$B_{(25/100)}$	Tol. $\pm 3\%$				$T_j=25^\circ\text{C}$		3996		K
Vincotech NTC Reference						$T_j=25^\circ\text{C}$			B	
Module Properties										
Thermal resistance, case to heatsink	R_{thCH}							tbd.		K/W
Module stray inductance	L_{sCE}							5		nH
Chip module lead resistance, terminals -chip	$R_{cc'1+EE'}$							tbd.		m Ω
Mounting torque	M						3.8	4	4.2	Nm
Terminal connection torque	M						6.7	7	7.4	Nm
Weight	G							tbd.		g

Ordering Code and Marking - Outline - Pinout
Ordering Code & Marking

Version	Ordering Code	in DataMatrix as	in packaging barcode as
12mm housing	10-F112R6A015SC-M438E08	M438-E08	M438-E08
12mm housing, without thermistor	10-F112R6A015SC01-M438E18	M438-E18	M438-E18

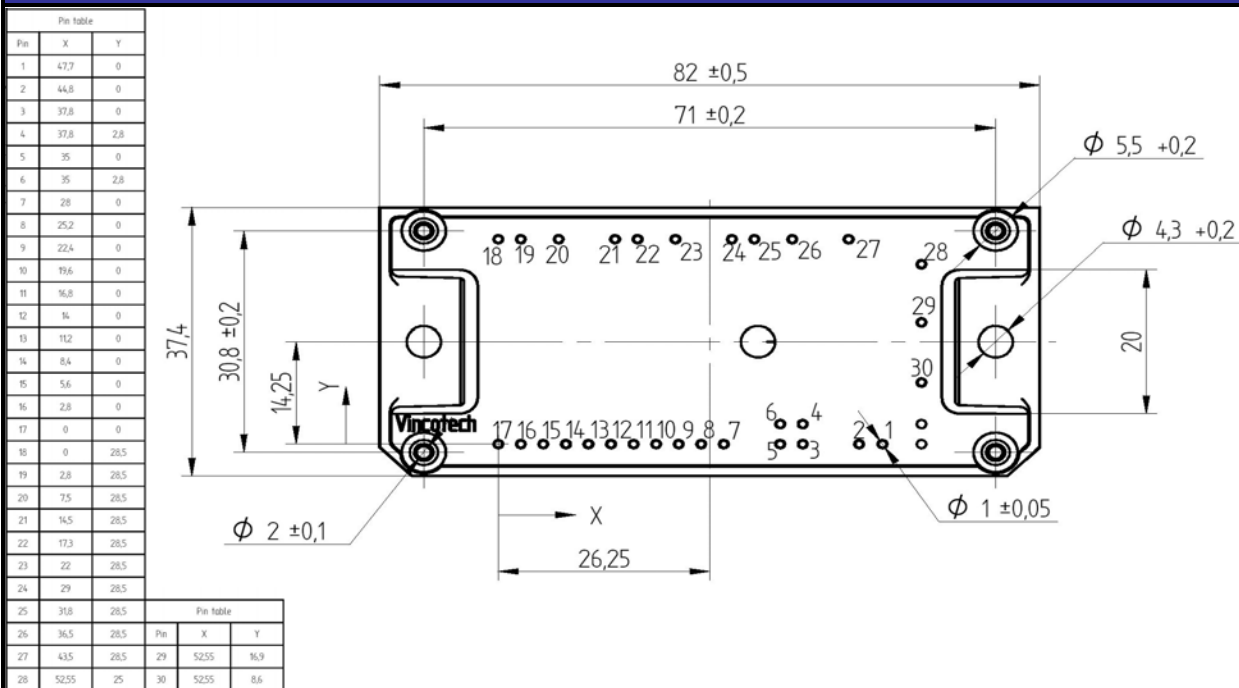
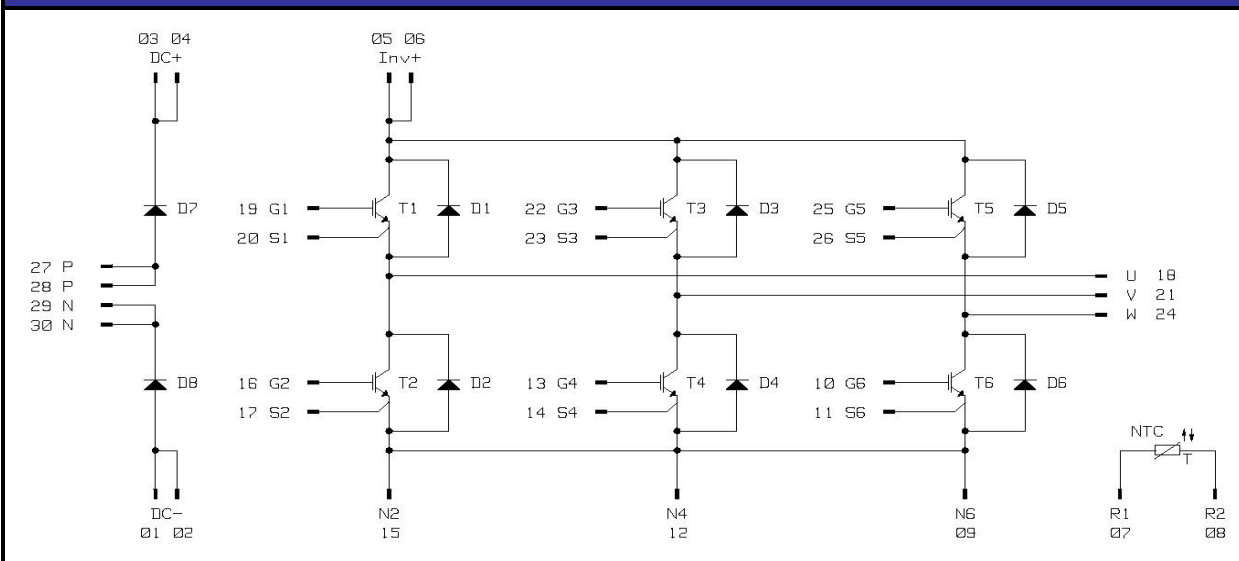
Outline

Pinout

PRODUCT STATUS DEFINITIONS

Datasheet Status	Product Status	Definition
Target	Formative or In Design	This datasheet contains the design specifications for product development. Specifications may change in any manner without notice. The data contained is exclusively intended for technically trained staff.
Preliminary	First Production	This datasheet contains preliminary data, and supplementary data may be published at a later date. Vincotech reserves the right to make changes at any time without notice in order to improve design. The data contained is exclusively intended for technically trained staff.
Final	Full Production	This datasheet contains final specifications. Vincotech reserves the right to make changes at any time without notice in order to improve design. The data contained is exclusively intended for technically trained staff.

DISCLAIMER

The information given in this datasheet describes the type of component and does not represent assured characteristics. For tested values please contact Vincotech. Vincotech reserves the right to make changes without further notice to any products herein to improve reliability, function or design. Vincotech does not assume any liability arising out of the application or use of any product or circuit described herein; neither does it convey any license under its patent rights, nor the rights of others.

LIFE SUPPORT POLICY

Vincotech products are not authorised for use as critical components in life support devices or systems without the express written approval of Vincotech.

As used herein:

1. Life support devices or systems are devices or systems which, (a) are intended for surgical implant into the body, or (b) support or sustain life, or (c) whose failure to perform when properly used in accordance with instructions for use provided in labelling can be reasonably expected to result in significant injury to the user.
2. A critical component is any component of a life support device or system whose failure to perform can be reasonably expected to cause the failure of the life support device or system, or to affect its safety or effectiveness.